

GDP/GLP35-40LJ, GDP/GLP45-55 MJ (E813)

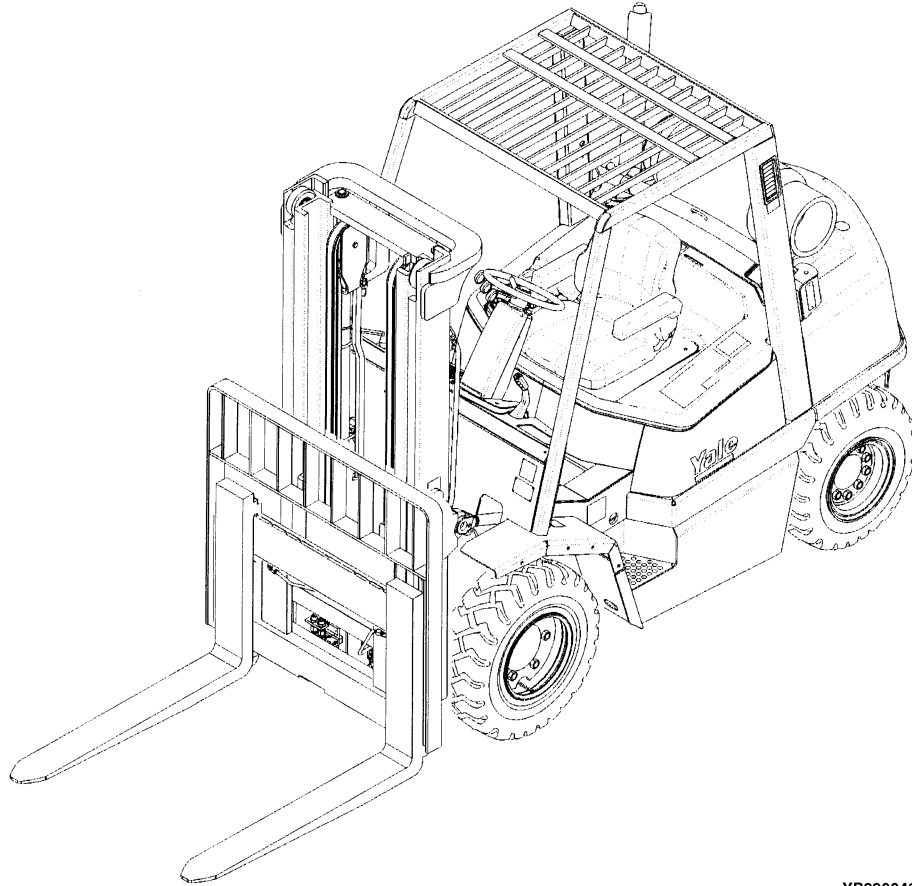

YP990043

1	GENERAL TRUCK	
2	DIESEL ENGINE	
3	LPG ENGINE (4.3L)	
4	FUEL SYSTEM	
5	ELECTRICAL SYSTEM	
6	STEERING SYSTEM	
7	BRAKE SYSTEM	
8	TRANSMISSION	
9	HYDRAULIC SYSTEM	
10	MAST-TWO STAGE LIMITED FREE-LIFT	
11	MAST-THREE STAGE FULL FREE-LIFT	
12	MAST-TWO STAGE FULL FREE-LIFT	
13	OPTIONS	
14	NUMERICAL INDEX	

ALPHABETICAL INDEX

DESCRIPTION	PAGE NO.
A	
ABBREVIATIONS QUICK REFERENCE SHEET	xi
AIR FILTER	
GLP AND GDP TIER II	4.50
AIR INTAKE AMD FILTER SYSTEM	
GLP	4.42
AIR INTAKE AND FILTER SYSTEM	
GDP TIER II	4.46
ALPHABETICAL INDEX	i
ALTERNATOR AND MOUNTING	
DIESEL	5.26
ASSEMBLED ENGINE	
GLP WITH POWER SHIFT TRANSMISSION	
PENDING PER ECN 93375-07⇒	3.20
TIER II	2.16
AUDIBLE ALARM	13.66
AUXILIARY TUBE EXTENSION KIT	
THREE STAGE FULL FREE-LIFT	13.42
TWO STAGE LIMITED FREE-LIFT	13.40
B	
BAFFLE AND ATTACHING PARTS	
DIESEL	2.10
LPG	3.12
BRAKE ASSEMBLY	
GLP/GDP35LJ, GLP/GDP40LJ	7.8
GLP/GDP45MJ, GLP/GDP50MJ, GLP/GDP55MJ	7.12
BRAKE RELAY ASSEMBLY	7.16
BRAKE SYSTEM	
HYDROSTATIC TRANSMISSION	7.6
POWERSHIFT TRANSMISSION	7.2
C	
CAB	
DOOR ASSEMBLY	13.30
CAB ATTACHING PARTS	
SHEET 1 OF 6	13.14
SHEET 2 OF 6	13.16
SHEET 3 OF 6	13.18
SHEET 4 OF 6	13.20
SHEET 5 OF 6	13.22
SHEET 6 OF 6	13.26
CAMSHAFT AND OIL PAN	3.26
CARBURETOR	
GLP WITH LOW EMISSIONS	
WITH HYDROSTATIC TRANSMISSION	4.24
CARRIAGE	

<https://www.ebooklibonline.com>

Hello dear friend!

Thank you very much for reading.

Enter the link into your browser.

The full manual is available for immediate download.

<https://www.ebooklibonline.com>

DESCRIPTION	PAGE NO.
-------------	----------

C (continued)

THREE STAGE FULL FREE-LIFT	11.24
TWO STAGE FULL FREE-LIFT	12.16
TWO STAGE LIMITED FREE-LIFT	10.14
CLUTCH PACKS	
T086 - T089 POWERSHIFT	
⇒S/N E813V02052B.....	8.14
T118 POWERSHIFT	
SINGLE SPEED	
S/N E813V02053B⇒	8.16
T120 - T121 POWERSHIFT	
TWO SPEED	
S/N E813V02053B⇒	8.18
COIL ASSEMBLY	
PENDING PER ECN 93375-07⇒	3.22
CONTROL VALVE	
HYDROSTATIC TRANSMISSION.....	8.46
POWERSHIFT TRANSMISSION.....	8.20
COOLING SYSTEM	
DIESEL	2.2
LPG.....	3.2
COUNTERWEIGHT	1.22
CRANKSHAFT AND PISTONS	
TIER II.....	2.24
CYLINDER BLOCK	
TIER II.....	2.18
CYLINDER HEAD	3.30
CYLINDER HEAD AND INDUCTION MANIFOLD	
TIER II.....	2.20

D

DIFFERENTIAL ASSEMBLY	
POWERSHIFT TRANSMISSION.....	8.30
DIRECTIONAL CONTROL PEDAL	4.74
DISTRIBUTOR	
GLP35LJ, GLP40LJ, GLP45MJ, GLP50MJ, GLP55MJ	5.32
DISTRIBUTOR ASSEMBLY	
GLP WITH POWER SHIFT TRANSMISSION	
PENDING PER ECN 93375-07⇒	5.34
DRIVE AXLE	
HYDROSTATIC TRANSMISSION.....	8.38
POWERSHIFT TRANSMISSION.....	8.34

E

ELECTRICAL SYSTEM	
ALTERNATOR AND BATTERY	
GLP35LJ, GLP40LJ, GLP45MJ, GLP50MJ, GLP55MJ.....	5.20
COWL	
HYDROSTATIC TRANSMISSION	5.8

DESCRIPTION	PAGE NO.
E (continued)	
POWERSHIFT TRANSMISSION	5.4
ENGINE	
GDP35LJ, GDP40LJ, GDP45MJ, GDP50MJ, GDP55MJ	5.22
GLP	5.16
THROTTLE-UP	
HYDROSTATIC TRANSMISSION	5.10
ENGINE AND ATTACHING PARTS	3.16
ENGINE BELT DRIVE AND ALTERNATOR MOUNTING	
GLP WITH POWER SHIFT TRANSMISSION	
PENDING PER ECN 93375-07⇒	3.10
ENGINE ELECTRICAL SYSTEM	
GLP WITH POWER SHIFT TRANSMISSION	
PENDING PER ECN 93375-07⇒	5.18
ENGINE FUEL SYSTEM	
GLP WITH POWER SHIFT TRANSMISSION	
PENDING PER ECN 93375-07⇒	4.30
ENGINE MOUNT	
TIER II	2.14
ENGINE MOUNTING	
LPG	3.14
EXHAUST	
THREE-WAY CATALYTIC CONVERTER	
WITH LOW EMISSIONS	3.42
TIER II	2.12
WITHOUT LOW EMISSIONS	3.40
EXHAUST GROUP	
LPG WITH POWER SHIFT TRANSMISSION	
PENDING PER ECN 93375-05⇒	3.44
EXHAUST MANIFOLD	3.23
TIER II	2.32
F	
F00T DIRECTIONAL CONTROL PEDAL AND BRACKET ASSEMBLY	
⇒PENDING PER ECN 93427	4.70
FAN DRIVE ASSEMBLY	
DIESEL	2.6
LPG	3.6
FENDER	
EXTENSION	
GLP/GDP35LJ, GLP/GDP40LJ	13.68
GLP/GDP45MJ, GLP/GDP50MJ, GLP/GDP55 MJ	13.70
FILTER AND LOCK-OFF VALVE	
GLP CLOSED LOOP	
WITH HYDROSTATIC TRANSMISSION	4.26
FLOOR PLATES AND COVERS	1.10
FOOT DIRECTIONAL CONTROL PEDAL AND BRACKET ASSEMBLY	
PENDING PER ECN 93427⇒	4.72
FORKS	

DESCRIPTION	PAGE NO.
-------------	----------

F (continued)

POLISHED FULL BOTTOM TAPER CLASS III AND IV.....	1.38
STANDARD TAPER CLASS III.....	1.36
CLASS IV	1.37
FREE-LIFT THREE STAGE FULL FREE-LIFT	11.16
FREE-LIFT CYLINDER TWO STAGE FULL FREE-LIFT	12.12
FREE-LIFT CYLINDERS THREE STAGE FULL FREE-LIFT	11.20
FUEL FILTER AND ATTACHING PARTS GDP TIER II.....	4.12
FUEL INJECTION PUMP TIER II ⇒S/N E813A01604B.....	2.38
WITH BLEED BACK SYSTEM S/N E813A01605B⇒.....	2.40
FUEL PUMP AND WATER SEPERATOR GDP TIER II.....	4.6
FUEL SENDER AND ATTACHING PARTS GDP TIER II.....	4.10
FUEL SUPPLY SYSTEM GDP TIER II.....	4.4
GLP POWERSHIFT TRANSMISSION	4.28
FUEL SYSTEM GLP CLOSED LOOP WITH HYDROSTATIC TRANSMISSION	4.20
GLP OPEN LOOP WITH HYDROSTATIC TRANSMISSION	4.14
FULL SUSPENSION SEAT PENDING PER ECN 74952⇒.....	1.20
SHEET 1 OF 2 ⇒PENDING PER ECN 74952	1.16
SHEET 2 OF 2 ⇒PENDING PER ECN 74952	1.18

G

GENERAL TRUCK.....	1.2
GOVERNOR GLP WITH HYDROSTATIC TRANSMISSION.....	4.18

DESCRIPTION	PAGE NO.
H	
HEADER HOSE	
THREE STAGE FULL FREE-LIFT	11.26
TWO STAGE FULL FREE-LIFT	12.20
TWO STAGE LIMITED FREE-LIFT	10.16
HEADLIGHTS, REAR LIGHTS, AND SIDE LIGHTS	
WITHOUT CAB	13.12
HEATER	
INSTALLATION	
GDP35LJ, GDP40LJ, GDP45MJ, GDP50MJ, GDP55MJ	13.36
GLP WITH POWERSHIFT TRANSMISSION	13.34
HOOD AND COVERS	1.6
HOW TO FIND THE DESIRED PART NUMBER	xiii
HOW TO USE THE ILLUSTRATED PARTS MANUAL	xiii
HYDRAULIC CONTROL LINES	
FOUR FUNCTION	9.12
THREE FUNCTION	9.10
HYDRAULIC CONTROL VALVE	
THREE AND FOUR FUNCTION	9.22
HYDRAULIC CONTROL VALVE ATTACHING PARTS	
FOUR FUNCTION	
WITH DETENTED LEVERS	9.18
THREE FUNCTION (TWO LEVERS WITHOUT DETENT)	
THREE FUNCTION (THREE LEVERS WITH AND WITHOUT DETENT)	9.14
WITH HYDROSTATIC TRANSMISSION	9.20
HYDRAULIC FILTER HOUSING	9.24
HYDRAULIC PUMP	9.28
HYDROSTATIC TRANSMISSION	8.44
HYDRAULIC PUMP MOUNTING	
HYDROSTATIC TRANSMISSION	8.42
HYDRAULIC SYSTEM	
WITH HYDROSTATIC TRANSMISSION	9.6
WITH POWERSHIFT TRANSMISSION	9.2
HYDRAULIC TEST PORT	9.26
I	
IDENTIFICATION OF ATTACHMENT AND SIDE-SHIFT CARRIAGE SERIAL NUMBERS	xvi
IDENTIFICATION OF MAST SERIAL NUMBER	xv
IDENTIFICATION OF TRUCK SERIAL NUMBER	xiv
INNER AND FREE LIFT MAST	
TWO STAGE FULL FREE-LIFT	12.6
INNER MAST	
THREE STAGE FULL FREE-LIFT	11.6
TWO STAGE LIMITED FREE-LIFT	10.4
INSTRUMENT PANEL	5.13
INTERMEDIATE MAST	
THREE STAGE FULL FREE-LIFT	11.4

DESCRIPTION	PAGE NO.
L	
LABELS	1.40
LIFTING EYES	13.64
LOAD BACKREST	1.34
LPG CONVERTER	
OPEN LOOP	
WITH HYDROSTATIC TRANSMISSION	4.17
LPG REGULATOR AND LOCK-OFF	
PENDING PER ECN 93375-07⇒	4.34
LPG TANK AND BRACKET	
FIXED	4.36
SWING OUT	4.38
LPG TANK BRACKET	
SWING OUT/DROP DOWN.....	4.40
M	
MAIN CYLINDER	
TWO STAGE LIMITED FREE-LIFT	10.10
MAIN LIFT	
THREE STAGE FULL FREE-LIFT	11.8
TWO STAGE LIMITED FREE-LIFT	10.6
MAIN LIFT CYLINDERS	
THREE STAGE FULL FREE-LIFT	11.12
TWO STAGE FULL FREE-LIFT	12.8
MANIFOLD VALVE	
POWERSHIFT TRANSMISSION.....	8.22
MAST INSTALLATION.....	9.30
MASTER CYLINDER AND BRAKE BOOSTER.....	7.14
MIRROR	
DUAL WITHOUT CAB	13.4
N	
NON-SUSPENSION SEAT	
PENDING PER ECN 74952⇒	1.14
⇒PENDING PER ECN 74952	1.12
O	
OIL COOLER	
TIER II.....	2.35
OIL FILTER	
TIER II.....	2.33
OIL PAN AND PUMP	
TIER II.....	2.26
OIL PUMP	3.38
OPERATOR MODULE	1.4
OUTER MAST	
THREE STAGE FULL FREE-LIFT	11.2
TWO STAGE LIMITED FREE-LIFT.....	10.2
OUTER MAST AND MAIN LIFT	
TWO STAGE FULL FREE-LIFT	12.2

DESCRIPTION	PAGE NO.
O (continued)	
OVERHEAD GUARD.....	1.26
P	
PARK BRAKE.....	7.18
R	
REAR DRIVE LIGHT WITHOUT CAB.....	13.10
REAR SCREEN.....	1.24
ROTARY EXHAUSTER TIER II.....	2.42
ROTATING BEACON WITHOUT CAB.....	13.8
S	
SHIFT LEVER.....	6.6
SIDE-SHIFT CARRIAGE TWO AND THREE STAGE FULL FREE-LIFT GLP/GDP35LJ, GLP/GDP40LJ.....	13.48
GLP/GDP45MJ, GLP/GDP50MJ, GLP/GDP55 MJ.....	13.50
TWO STAGE LIMITED FREE-LIFT GLP/GDP35LJ, GLP/GDP40LJ.....	13.44
GLP/GDP45MJ, GLP/GDP50MJ, GLP/GDP55MJ.....	13.46
SIDE-SHIFT CARRIAGE FRAME 1201 MM TWO STAGE LIMITED FREE-LIFT GLP/GDP35LJ, GLP/GDP40LJ.....	13.52
1201 MM, TWO AND THREE STAGE FULL FREE-LIFT GLP/GDP35LJ, GLP/GDP40LJ.....	13.58
1505 MM TWO STAGE LIMITED FREE-LIFT GLP/GDP35LJ, GLP/GDP40LJ.....	13.54
1505 MM, TWO AND THREE STAGE FULL FREE-LIFT GLP/GDP35LJ, GLP/GDP40LJ.....	13.60
TWO AND THREE STAGE FULL FREE-LIFT GLP/GDP45MJ, GLP/GDP50MJ, GLP/GDP55MJ.....	13.62
TWO STAGE FULL FREE-LIFT GLP/GDP45MJ, GLP/GDP50MJ, GLP/GDP55 MJ.....	13.56
SOUND REDUCTION.....	1.28
SPOT LIGHT WITHOUT CAB.....	13.6
STARTER GLP.....	5.28
STARTER MOTOR GDP35LJ, GDP40LJ, GDP45MJ, GDP50MJ, GDP55MJ.....	5.30
STEER CYLINDER.....	6.12
STEER TIRES AND WHEELS.....	6.16
STEERING AXLE.....	6.8
STEERING COLUMN.....	6.4
STEERING PUMP.....	6.14

DESCRIPTION	PAGE NO.
S (continued)	
STEERING SYSTEM	6.2
T	
THROTTLE ARM ASSEMBLY	4.68
THROTTLE BODY AND LPG MIXER WITH POWER SHIFT TRANSMISSION PENDING PER ECN 93375-07⇒	4.32
THROTTLE LINKAGE	
GDP FOOT DIRECTIONAL CONTROL WITH HYDROSTATIC TRANSMISSION	4.64
GDP FORWARD AND REVERSE WITH HYDROSTATIC TRANSMISSION	4.62
GDP TIER II POWERSHIFT TRANSMISSION	4.60
GLP POWERSHIFT TRANSMISSION	4.52
GLP FOOT DIRECTIONAL CONTROL WITH HYDROSTATIC TRANSMISSION	4.56
GLP FORWARD AND REVERSE LEVER WITH HYDROSTATIC TRANSMISSION	4.54
TILT CYLINDER	9.32
TIMING GEAR	
TIER II	2.30
TIRE AND WHEEL	
DRIVE WHEEL	
RADIAL	13.78
DUAL DRIVE WHEEL	13.76
SINGLE DRIVE WHEEL	
GLP/GDP35LJ, GLP/GDP40LJ	13.72
GLP/GDP45MJ, GLP/GDP50MJ, GLP/GDP55 MJ	13.74
STEERING	13.82
STEERING RADIAL	
7.00 X 12 PNEUMATIC TIRE	13.84
TORQUE CONVERTER	
POWERSHIFT TRANSMISSION	8.26
TRANSMISSION	
T086 - T089 POWERSHIFT	
SHEET 1 OF 2	
⇒S/N E813V02052B	8.2
SHEET 2 OF 2	
⇒S/N E813V02052B	8.4
T118 - T121 POWERSHIFT	
SHEET 1 OF 2	
S/N E813V02053B⇒	8.8
SHEET 2 OF 2	
S/N E813V02053B⇒	8.10
TRANSMISSION CONTROLLER	
HYDROSTATIC TRANSMISSION	5.12

DESCRIPTION	PAGE NO.
T (continued)	
TRANSMISSION LINES	
POWERSHIFT TRANSMISSION.....	8.28
TRANSMISSION MOUNTING	
POWERSHIFT TRANSMISSION.....	8.32
U	
UNDERCARRIAGE PAN	
PENDING PER ECN 92950⇒.....	1.32
⇒PENDING PER ECN 92950.....	1.30
V	
VALVE	
HIGH AND LOW	
POWERSHIFT TRANSMISSION.....	8.24
VALVE COVER AND INLET MANIFOLD.....	3.32
GLP WITH POWER SHIFT TRANSMISSION	
PENDING PER ECN 93375-07⇒.....	3.34
VALVE COVER AND ROCKER ARM SHAFT	
TIER II.....	2.22
W	
WATER PUMP AND OUTLET	
TIER II.....	2.28
WATER SEPARATOR	
GDP TIER II.....	4.8
WIRE HARNESS	
AUXILIARY LIGHTS	
WORKLIGHTS.....	13.39
BRAKE PRESSURE SWITCH	
Pending Per ECN 93150⇒.....	5.77
⇒Pending Per ECN 93150.....	5.76
DIAGNOSTIC.....	5.41
ENGINE, GLP GM V6, 4.3L	
SHEET 1 OF 2.....	5.56
ENGINE, GLP, GM V6, 4.3L	
SHEET 2 OF 2.....	5.58
GDP TIER II ENGINE	
⇒S/N E813A01842C.....	5.36
S/N E813A01843C⇒.....	5.38
GLP REGULATOR	
PENDING PER ECN 93375-07⇒.....	5.66
GLP SWITCH.....	5.40
HYDROSTATIC THROTTLE-UP	
FOUR FUNCTION.....	5.72
THREE FUNCTION.....	5.70
INTERFACE, GLP	
WITH POWER SHIFT TRANSMISSION	
PENDING PER ECN 93375-07⇒.....	5.68

DESCRIPTION	PAGE NO.
-------------	----------

W (continued)

MODULE	
HYDROSTATIC TRANSMISSION	5.48
POWERSHIFT TRANSMISSION	5.42
POWERSHIFT TRANSMISSION CONTROL	
PENDING PER ECN 74952⇒	5.84
Pending Per ECN 93150⇒.....	5.80
⇒Pending Per ECN 93150.....	5.78
REVERSE ALARM	13.38
THROTTLE-UP SWITCH	
WITH HYDROSTATIC TRANSMISSION	5.74
WIRE HARNESS - ENGINE	
GLP WITH POWER SHIFT TRANSMISSION	
SHEET 1 OF 2	
PENDING PER ECN 93375-07⇒.....	5.61
SHEET 2 OF 2	
PENDING PER ECN 93375-07⇒.....	5.64

**SECTION 1
GENERAL TRUCK**

DESCRIPTION	PAGE
COUNTERWEIGHT	1.22
FLOOR PLATES AND COVERS	1.10
FORKS	
POLISHED FULL BOTTOM TAPER	
CLASS III AND IV.....	1.38
STANDARD TAPER	
CLASS III.....	1.36
CLASS IV	1.37
FULL SUSPENSION SEAT	
PENDING PER ECN 74952⇒	1.20
SHEET 1 OF 2	
⇒PENDING PER ECN 74952	1.16
SHEET 2 OF 2	
⇒PENDING PER ECN 74952	1.18
GENERAL TRUCK	1.2
HOOD AND COVERS	1.6
LABELS	1.40
LOAD BACKREST	1.34
NON-SUSPENSION SEAT	
PENDING PER ECN 74952⇒	1.14
⇒PENDING PER ECN 74952	1.12
OPERATOR MODULE	1.4
OVERHEAD GUARD.....	1.26
REAR SCREEN.....	1.24
SOUND REDUCTION	1.28
UNDERCARRIAGE PAN	
PENDING PER ECN 92950⇒	1.32
⇒PENDING PER ECN 92950	1.30

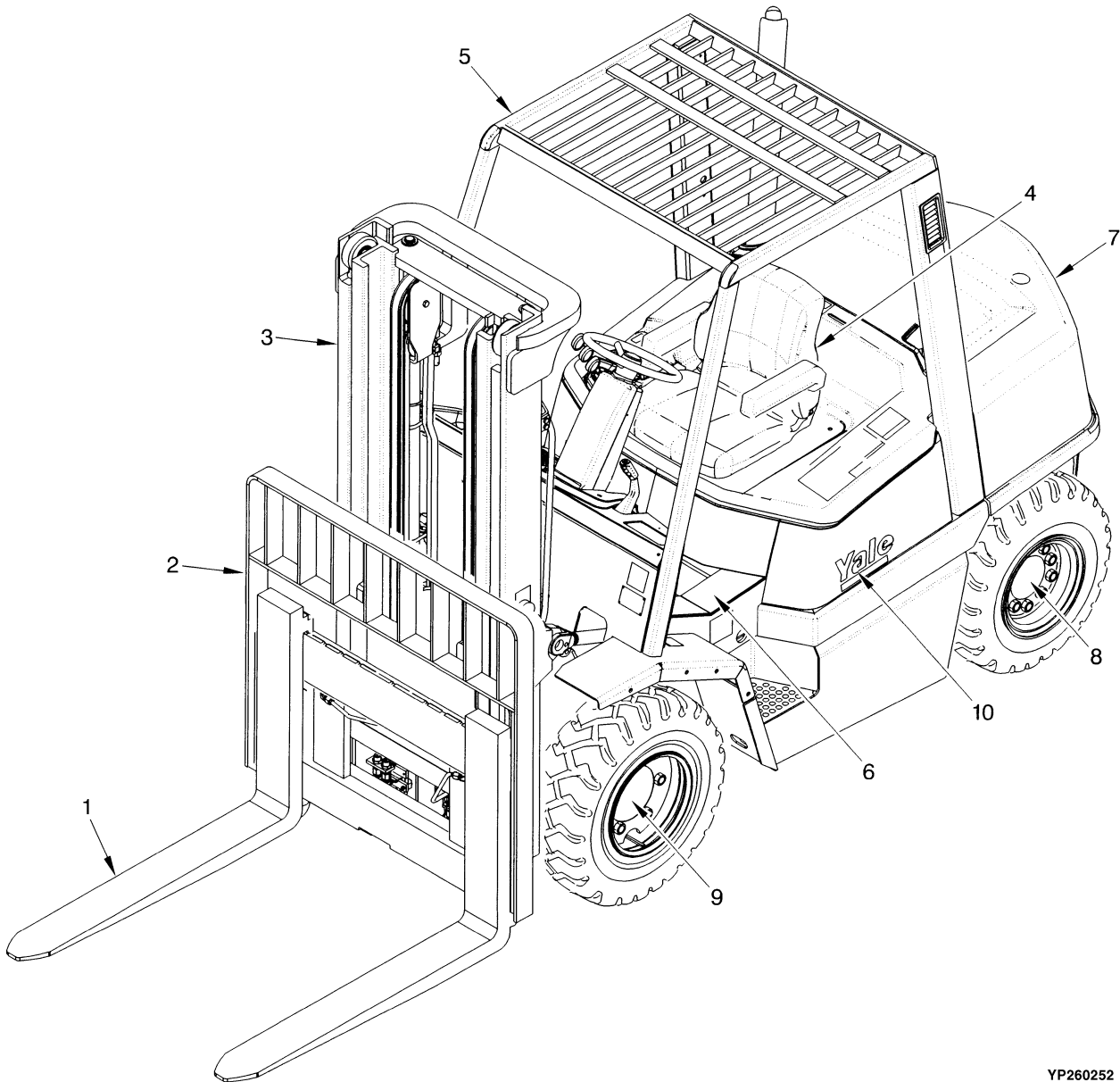

YP260252

ITEM	PART NO.	DESCRIPTION	QTY
1	Forks (☞ Page 1.36, ☞ Page 1.37, ☞ Page 1.38)	1
2	Load Backrest (☞ Page 1.34)	1
3	Mast-Two Stage Limited Free-Lift (☞ Page 10.2)	1
3	Mast-Two Stage Full Free-Lift (☞ Page 12.2)	1
3	Mast-Three Stage Full Free-Lift (☞ Page 11.2)	1
4	Seats (☞ Page 1.16, ☞ Page 1.18, ☞ Page 1.12)	1
5	Overhead Guard (☞ Page 1.26)	1
6	Floor Plates, Hood, And Covers (☞ Page 1.10, ☞ Page 1.6)	1
7	Counterweight (☞ Page 1.22)	1
8	Steering System (☞ Page 6.2)	1
9	Drive System (☞ Page 8.38)	1
10	Electrical Systems (☞ Page 5.8)	1
10	Engine And Fuel Assemblies (☞ Page 4.14)	1

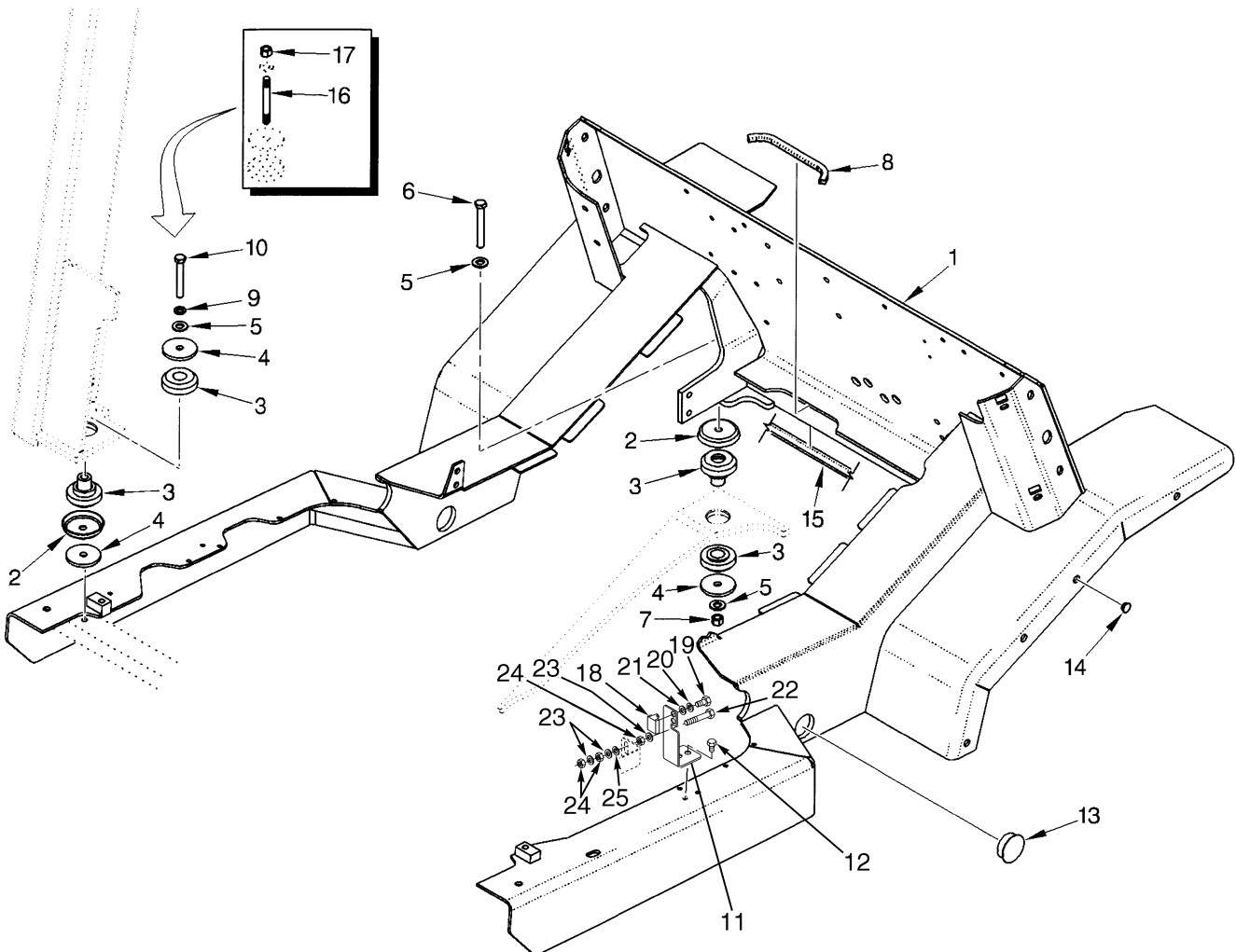
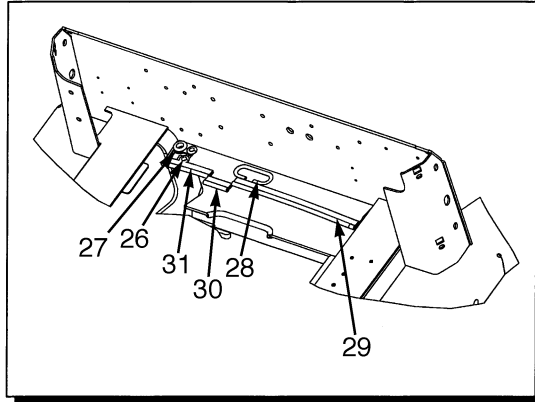

ITEM	PART NO.	DESCRIPTION	QTY
1	Operator Module.....	1
2	580007036	Cup.....	4
3	580007035	Mount.....	4
4	505966562	Washer.....	6
5	504233271	Washer.....	6
6	931015915	Capscrew.....	2
7	449015115	Locknut.....	2
8	580013487	Trim.....	1
9	449022017	Lockwasher.....	2
10	931015915	Capscrew.....	2
11	524141538	Bracket.....	1
12	504230231	Screw.....	3
13	580010741	Plug.....	2
14	580010743	Plug.....	8
15	580012678	Seal.....	AR
16	504323759	Stud (Optional).....	2
16	501702903	Sealant.....	AR
17	449015115	Locknut (Optional).....	2
18	580016557	Latch (Rotary).....	1
19	203142800	Capscrew.....	2
20	015026000	Lockwasher.....	2
21	016103500	Washer.....	2
22	580032781	Capscrew.....	1
23	016104000	Washer.....	2
24	014970900	Nut.....	2
25	015026400	Lockwasher.....	1
26	900003245	Grommet.....	2
27	032616700	Grommet.....	1
28	524159381	Trim Seal.....	1
29	524159382	Trim Seal.....	1
30	524159383	Trim Seal.....	1
31	524159384	Trim Seal.....	1

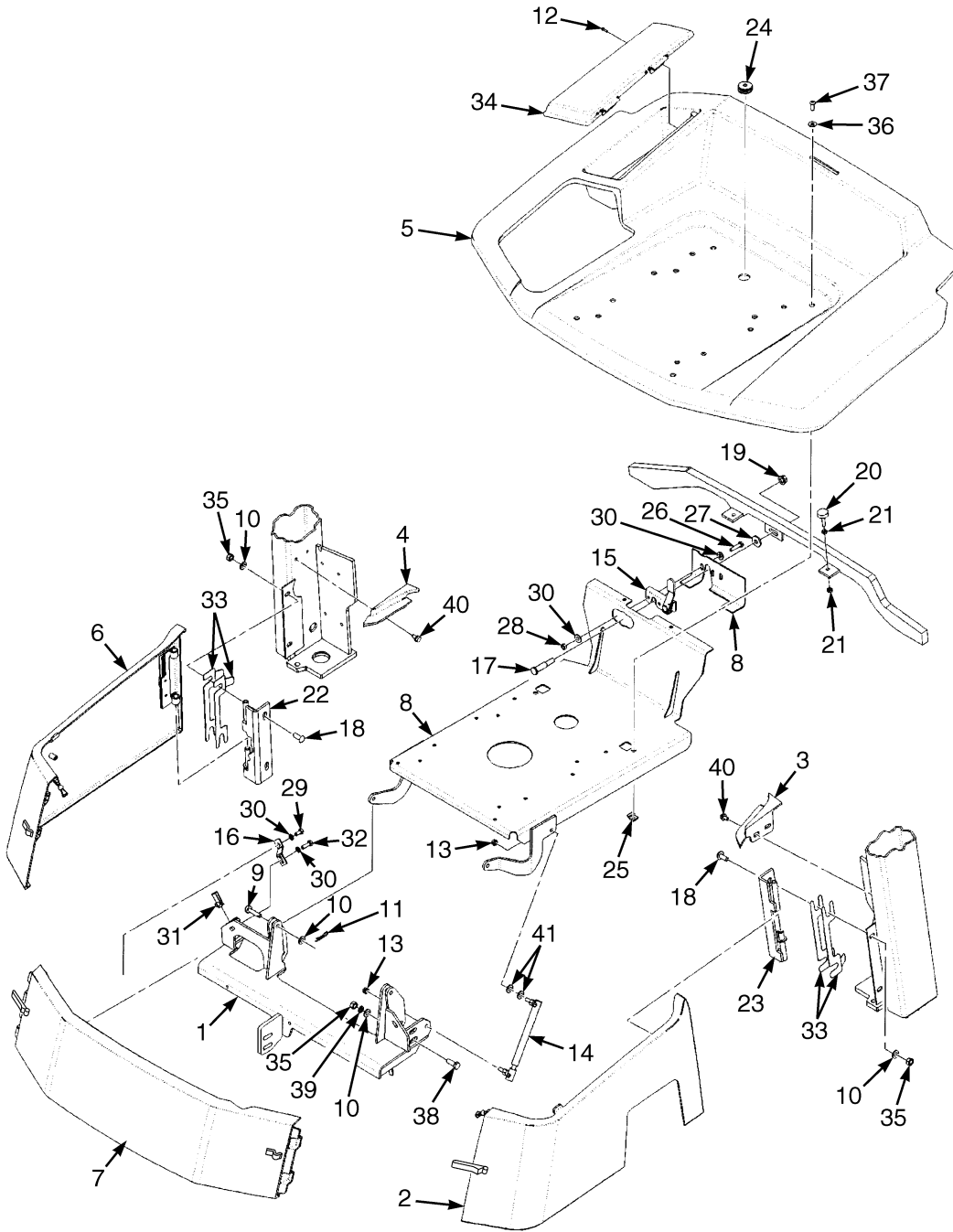

ITEM	PART NO.	DESCRIPTION	QTY
1	524178934	Crossmember	1
2	504316732	Panel	1
2	504316733	Panel	1
2	580012765	Latch	1
3	524143545	Cover (RH) (With Cab)	1
3	504316731	Cover (LH) (Without Cab)	1
4	524143544	Cover (LH) (With Cab)	1
4	504316730	Cover (RH) (Without Cab)	1
5	a 504316727	Hood	1
5	b 524248818	Hood	1
6	504316726	Panel (RH)	1
7	504316725	Cover (Front)	1
7	580012765	Latch	2
8	524178935	Seat Pan	1
9	912326300	Pin (Hinge)	2
10	449021006	Washer	6
11	965801908	Cotter Pin	2
12	505977534	Rivet	4
13	504229298	Nut	4
14	580033641	Gas Spring Assembly	2
14	580032356	Ball Stud	2
15	504316710	Latch	1
16	504308734	Bracket	2
17	580014984	Striker	1
18	500092901	Bolt	4
19	580008135	Nut	1
20	518790649	Stop Screw	2
21	014970800	Nut	4
22	580052055	Hinge (RH)	1
22	580052258	Nut (Not illustrated)	4
23	580014407	Hinge (LH)	1
24	a 518790699	Grommet	1
24	b 580051832	Grommet	1
25	580048480	Nut	2
26	580037152	Capscrew	2
27	580037152	Capscrew	2
28	524139011	Trim	2
29	449001415	Capscrew	2
30	449022016	Lockwasher	6
31	518796652	Clip Nut	2
32	449001014	Capscrew	2
33	504316739	Shim (1,194 mm)	AR
34	504317788	Door (Tool Box)	1
35	909882404	Nut	4
36	580003569	Washer	2
37	505976542	Capscrew	2
38	449001302	Capscrew	4
39	449022013	Lockwasher	4

HOOD AND COVERS

ITEM	PART NO.	DESCRIPTION	QTY
40	504230231	Screw.....	4
41	449021001	Washer	4

FOOTNOTES:

a ⇒ PENDING PER ECN 74952

b PENDING PER ECN 74952 ⇒

FLOOR PLATES AND COVERS

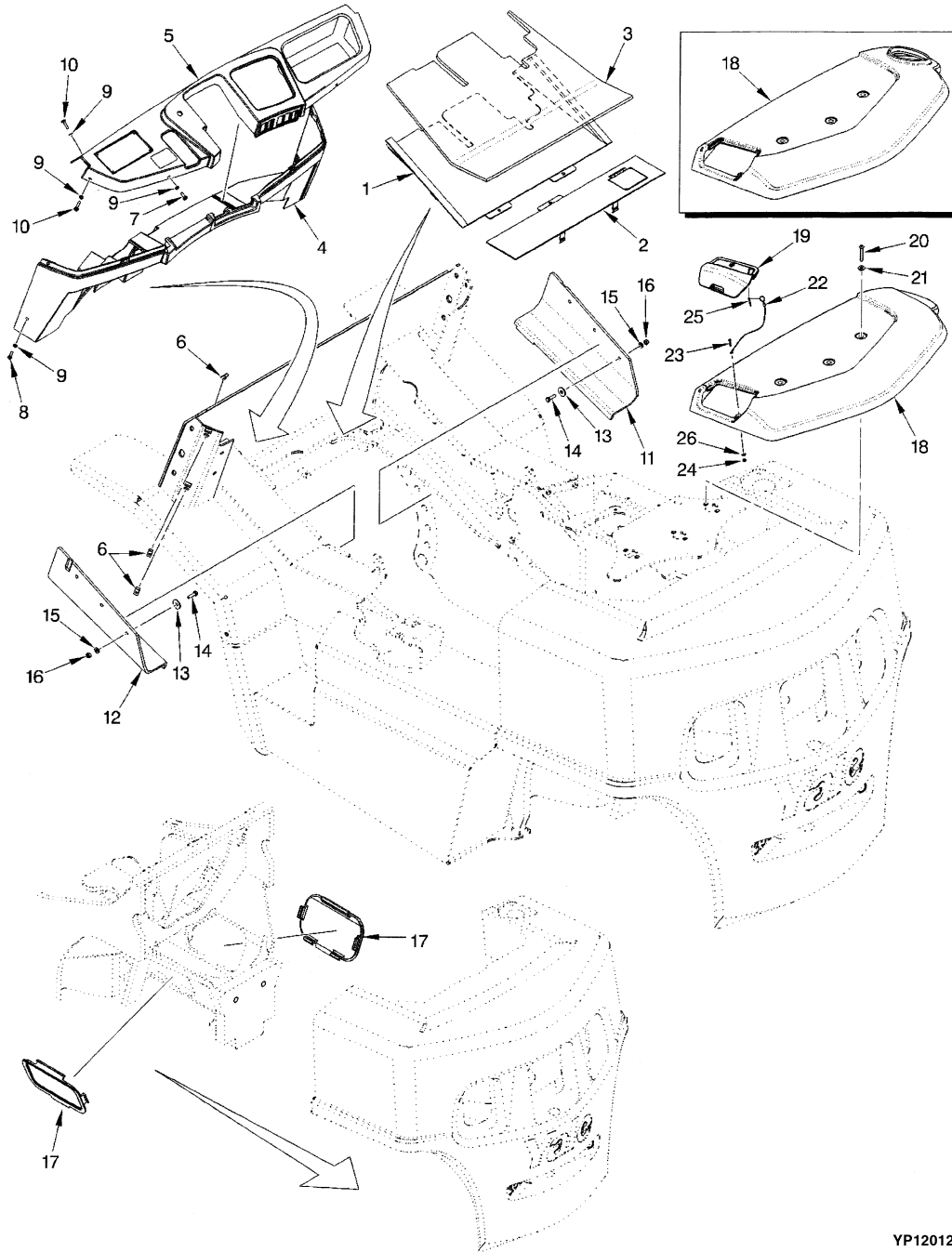

YP120124

ITEM	PART NO.	DESCRIPTION	QTY
1	504293725	Floorplate	1
2	504293721	Floorplate	1
3	504314712	Floormat	1
4	504292798	Cover	1
5	504292799	Dash	1
6	505970526	Nut (Foldover).....	6
7	580035541	Screw.....	3
8	580035543	Screw.....	2
9	580009298	Washer	9
10	580035542	Screw.....	4
11	504317748	Flap (RH).....	1
12	504317749	Flap (LH).....	1
13	580007199	Washer	6
14	449001134	Capscrew.....	6
15	449021001	Washer	6
16	449015098	Locknut.....	6
17	580010272	Cover	2
18	504310722	Cover (Radiator) (Overhead Exhaust)	1
18	504292784	Cover (Radiator) (Counterweight Exhaust).....	1
19	a 504308785	Door (Radiator Cap) (Overhead Exhaust)	1
19	a 504310723	Door (Radiator Cap) (Counterweight Exhaust).....	1
20	580011980	Capscrew.....	3
21	580003569	Washer	3
22	580011736	Lanyard.....	1
23	580013716	Screw.....	1
24	449015112	Nut.....	1
25	015416200	Cotter Pin	1
26	449021003	Washer	1

FOOTNOTES:

a GDP35LJ Thru GDP55MJ

NON-SUSPENSION SEAT
(⇒PENDING PER ECN 74952)

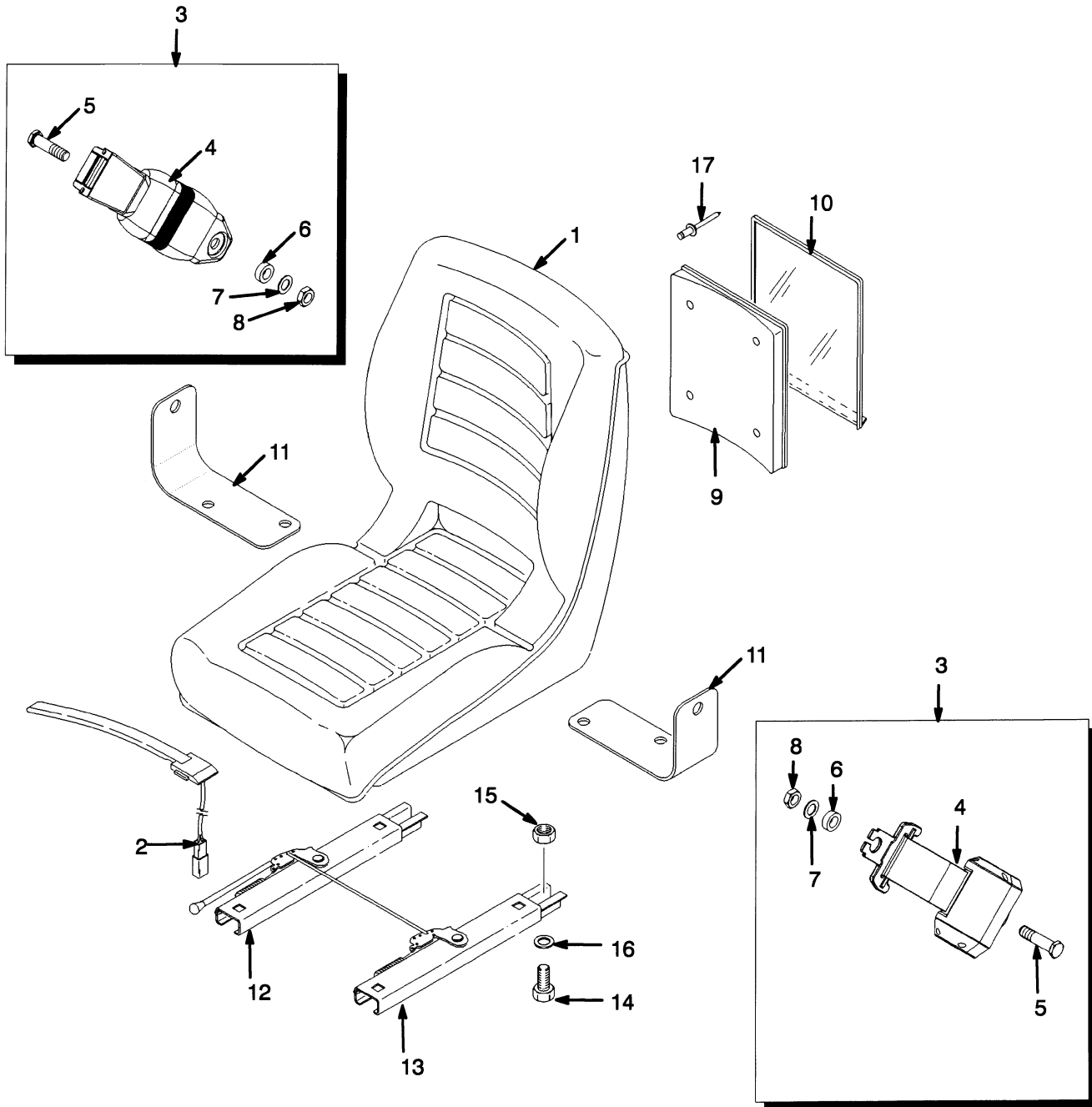

YP120120



Suggest:

For more complete manuals. Please go to the home page.

<https://www.ebooklibonline.com>

If the above button click is invalid. Please download this document first, and then click the above link to download the complete manual.

Thank you so much for reading

ITEM	PART NO.	DESCRIPTION	QTY
	580008424	Non-Suspension Seat.....	1
1	504232248	Seat.....	1
2	504305734	Switch Assembly	1
3	580010327	Seat Belt Kit	1
4	Seat Belt	1
5	Screw	2
6	Washer.....	2
7	Washer.....	2
8	Nut	2
9	519996801	Base	1
10	519996803	Cover	1
11	580014487	Bracket	2
12	580014485	Seat Rail.....	1
13	580014486	Seat Rail.....	1
14	062306700	Capscrew.....	4
15	504238298	Nut.....	4
16	023604600	Washer	4
17	Rivet	4

**NON-SUSPENSION SEAT
(PENDING PER ECN 74952⇒)**

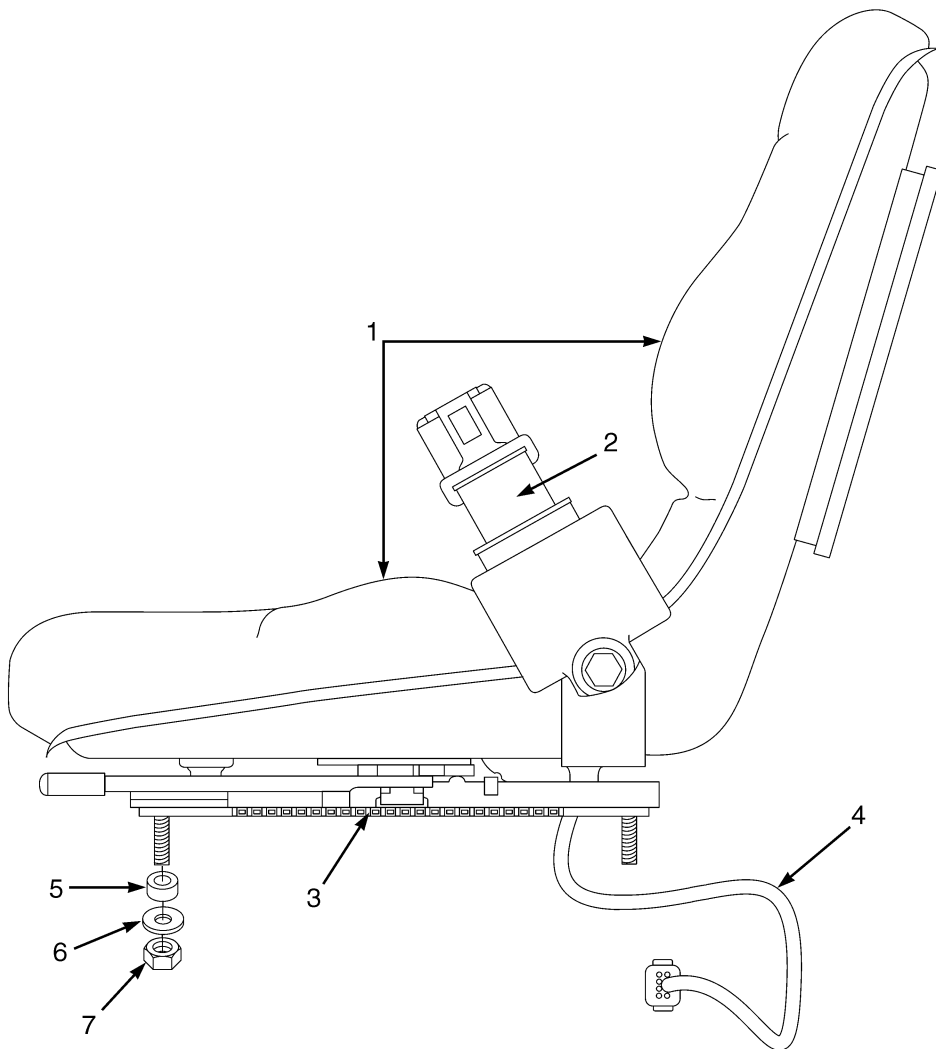

<https://www.ebooklibonline.com>

Hello dear friend!

Thank you very much for reading.

Enter the link into your browser.

The full manual is available for immediate download.

<https://www.ebooklibonline.com>