

**ERP1.6-2.0ATF
(D807)**

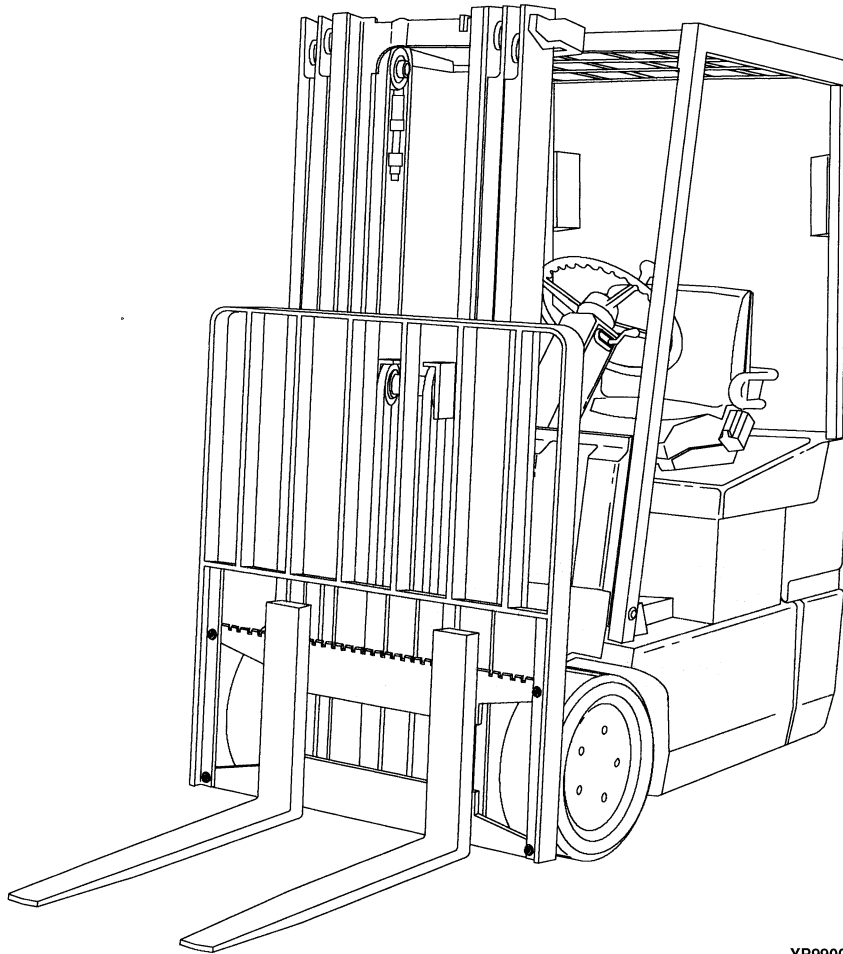

YP990092

1	GENERAL TRUCK	
2	ELECTRICAL SYSTEM	
3	DRIVE UNIT	
4	STEERING SYSTEM	
5	BRAKE SYSTEM	
6	HYDRAULIC SYSTEM	
7	MAST-TWO STAGE LIMITED FREE-LIFT	
8	MAST-THREE STAGE FULL FREE-LIFT	
9	MAST-TWO STAGE FULL FREE-LIFT	
10	HEADER HOSE GROUP	
11	OPTIONS	
12	NUMERICAL INDEX	

ALPHABETICAL INDEX

DESCRIPTION	PAGE NO.
A	
ABBREVIATIONS QUICK REFERENCE SHEET	vii
ACCELERATOR PEDAL AND LINKAGE	5.8
ALPHABETICAL INDEX.....	i
B	
BACK-UP ALARM	11.16
BATTERY COMPARTMENT AND COVERS	1.4
BATTERY CONNECTOR	2.14
BRAKE ASSEMBLY	5.10
C	
CALIPER ASSEMBLY	
FOOT-OPERATED PARKING BRAKE.....	5.11
CARRIAGE	
SIX ROLLER	
TWO STAGE FULL FREE-LIFT	9.16
SIX-ROLLER	
THREE STAGE FULL FREE-LIFT	8.16
TWO STAGE LIMITED FREE-LIFT.....	7.10
CONTROL VALVE LINKAGE	
LOWER	
THREE AND FOUR FUNCTION	
D/B 07/2003⇒	6.10
⇒D/B 07/2003	6.6
UPPER	
THREE AND FOUR FUNCTION.....	6.4
UPPER LIFT AND TILT.....	6.2
COUNTERWEIGHT	1.24
D	
DASH DISPLAY	2.52
DC CONVERTER.....	11.2
DECAL AND PLATE LOCATION.....	1.18
DRIVE TIRE AND WHEEL ASSEMBLY	
SUPER CUSHION	
ERP-20ATF	3.13
E	
ELECTRICAL ASSEMBLY	
S/N D807A-3883Y⇒.....	2.6
S/N D807A02684W↔S/N D807A03882Y	2.2

<https://www.ebooklibonline.com>

Hello dear friend!

Thank you very much for reading.

Enter the link into your browser.

The full manual is available for immediate download.

<https://www.ebooklibonline.com>

DESCRIPTION	PAGE NO.
F	
FOOT DIRECTIONAL CONTROL	
D/B 12/2002⇒	5.16
⇒D/B 12/2002	5.14
FREE LIFT	
THREE STAGE FULL FREE-LIFT	8.10
FREE LIFT CYLINDER	
THREE STAGE FULL FREE-LIFT	8.14
FREE-LIFT	
TWO STAGE FULL FREE-LIFT	9.8
FREE-LIFT CYLINDER	
TWO STAGE FULL FREE-LIFT	9.14
FRONT HEADLIGHTS	11.10
G	
GENERAL TRUCK	1.2
H	
HEADER HOSE	
TWO STAGE LIMITED FREE-LIFT	7.16
HOSE TAKE-UP	
FOUR FUNCTION	
THREE STAGE FULL FREE-LIFT	10.12
TWO STAGE FULL FREE-LIFT	10.8
TWO STAGE LIMITED FREE-LIFT	10.4
THREE FUNCTION	
THREE STAGE FULL FREE-LIFT	10.10
TWO STAGE FULL FREE-LIFT	10.6
TWO STAGE LIMITED FREE-LIFT	10.2
HOSE TAKE-UP CONNECTION	10.14
HOW TO FIND THE DESIRED PART NUMBER	ix
HOW TO USE THE ILLUSTRATED PARTS MANUAL	ix
HYDRAULIC BRAKE SYSTEM	5.4
HYDRAULIC CALIPER ASSEMBLY	5.2
HYDRAULIC CONTACTOR ASSEMBLY	
ONE-SPEED	2.20
TWO SPEED	2.22
HYDRAULIC CONTROL VALVE	
FOUR SPOOL	6.16
THREE SPOOL	6.14
HYDRAULIC HOSE AND FITTINGS	6.22
HYDRAULIC MOTOR	
12 CC PUMP	
⇒S/N D807A-04122Z	2.50 2.48
S/N D807A-04123Z⇒	2.46
19 CC PUMP	
⇒S/N D807A-04122Z	2.42 2.40
S/N D807A-04123Z⇒	2.44
HYDRAULIC PUMP ASSEMBLY	
12 CC	

DESCRIPTION	PAGE NO.
-------------	----------

H (continued)

OPTIONAL	6.30
STANDARD	6.32
12CC SPLINED SHAFT	
D/B 06/2002⇒	6.34
19 CC	
D/B 06/2000⇒	6.37
⇒D/B 06/2000	6.36
OPTIONAL	6.38

I

IDENTIFICATION OF ATTACHMENT AND SIDE-SHIFT CARRIAGE SERIAL NUMBERS	xii
IDENTIFICATION OF MAST SERIAL NUMBER	xi
IDENTIFICATION OF TRUCK SERIAL NUMBER	x
INNER MAST	
THREE STAGE FULL FREE-LIFT	8.6
TWO STAGE FULL FREE-LIFT	9.4
TWO STAGE LIMITED FREE-LIFT	7.4
INTEGRAL SIDE-SHIFT CARRIAGE	9.18
THREE STAGE FULL FREE-LIFT	8.18
TWO STAGE LIMITED FREE-LIFT	7.12
INTEGRAL SIDE-SHIFT HYDRAULIC HOSES	
THREE STAGE FULL FREE-LIFT	8.20
TWO STAGE FULL FREE-LIFT	9.20
TWO STAGE LIMITED FREE-LIFT	7.14
INTERMEDIATE MAST	
THREE STAGE FULL FREE-LIFT	8.4

L

LIFT	
TWO STAGE LIMITED FREE-LIFT	7.6
LIFT CYLINDER	
TWO STAGE LIMITED FREE-LIFT	7.8
LIFT PUMP AND MOTOR ATTACHING PARTS	
12 CC	6.26
19 CC	6.28
LIFT PUMP CONTACTOR ASSEMBLY	
ONE-SPEED	2.16
TWO-SPEED	2.18
LINE CONTACTOR	2.24
LOAD BACKREST	1.10
LOAD FORK ASSEMBLIES	
D/B 10/2001⇒	1.22
⇒D/B 10/2001	1.20

DESCRIPTION	PAGE NO.
M	
MAIN CYLINDER	
LEFT HAND	
TWO STAGE FULL FREE-LIFT	9.10
RIGHT HAND	
TWO STAGE FULL FREE-LIFT	9.12
THREE STAGE FULL FREE-LIFT	8.12
MAIN LIFT	
THREE STAGE FULL FREE-LIFT	8.8
TWO STAGE FULL FREE-LIFT	9.6
MASTER DRIVE UNIT	3.2
MOTOR COOLING FAN	11.18
N	
NON-SUSPENSION SEAT	1.12
O	
OUTER MAST	
THREE STAGE FULL FREE-LIFT	8.2
TWO STAGE FULL FREE-LIFT	9.2
TWO STAGE LIMITED FREE-LIFT	7.2
OVERHEAD GUARD	1.8
P	
PARKING BRAKE	
FOOT-OPERATED	5.6
POWER STEERING ASSEMBLY	
ON-DEMAND	2.10
WITHOUT ON-DEMAND	2.12
POWER STEERING CONTACTOR	2.26
R	
REAR DRIVING LIGHTS	11.8
S	
SEMISUSPENSION SEAT	
SHEET 1 OF 2	1.14
SHEET 2 OF 2	1.16
SHIFT LEVERS	4.8
SIDE-SHIFT ASSEMBLY	6.44
SIDE-SHIFT CYLINDER	
D/B 10/2000⇒	6.43
⇒D/B 10/2000	6.42
SPOTLIGHT	11.14
STEER AXLE	
S/N D807-03890Y⇒	4.14
S/N D807A02684W↔S/N D807A03890Y	4.12
STEER TIRE AND WHEEL ASSEMBLY	
PNEUMATIC	
ERP-16ATF AND ERP-18ATF	4.26

DESCRIPTION	PAGE NO.
S (continued)	
SOLID PNEUMATIC	4.24
STEERING COLUMN.....	4.6
STEERING HAND PUMP.....	4.10
STEERING HYDRAULIC SYSTEM	
D/B 07/2003⇒	4.4
⇒D/B 07/2003	4.2
STEERING MOTOR	
PREMIUM	
D/B 04/2003⇒.....	2.30
⇒D/B 04/2003.....	2.32
STANDARD.....	2.28
STEERING PUMP	
⇒S/N D807A-03320X.....	4.18
S/N D807A-03321X⇒.....	4.20
STROBE LIGHT/REAR LIGHT COMBINATION.....	11.12
T	
TAIL, BRAKE, AND BACK-UP LIGHTS	
⇒S/N D807A04993A.....	11.4
S/N D807A04994A⇒.....	11.6
TILT CYLINDER	
ROD ENDS AND PINS.....	6.18
TILT CYLINDER ASSEMBLY	6.20
TIRE AND WHEEL ASSEMBLY	
CUSHION	4.22
PNEUMATIC	
ERP-16ATF AND ERP-18ATF	3.14
SOLID PNEUMATIC	3.15
SUPER CUSHION	
ERP-16ATF AND ERP-18ATF	3.12
TIRE AND WHEEL MOUNTING	
DRIVE.....	3.11
TRACTION MOTOR	
PREMIUM	
⇒S/N D807A-03462Y	2.36
S/N D807A-03463Y⇒.....	2.38
STANDARD	
⇒S/N D807A-03462Y	2.34
TRANSMISSION	
D/B 06/2001⇒	3.4
⇒D/B 06/2001	3.8
TWO-SPEED HYDRAULIC CONTACTOR ASSEMBLY	6.40
W	
WIRE HARNESS	
MAIN	
SHEET 1 OF 2	
⇒S/N D807A3882Y.....	2.54

DESCRIPTION	PAGE NO.
-------------	----------

W (continued)

SHEET 1 OF 2	
S/N D807A3883Y⇒.....	2.58
SHEET 2 OF 2	
⇒S/N D807A3882Y.....	2.56
S/N D807A3883Y⇒.....	2.60

**SECTION 1
GENERAL TRUCK**

DESCRIPTION	PAGE
BATTERY COMPARTMENT AND COVERS	1.4
COUNTERWEIGHT	1.24
DECAL AND PLATE LOCATION	1.18
GENERAL TRUCK	1.2
LOAD BACKREST	1.10
LOAD FORK ASSEMBLIES	
D/B 10/2001⇒	1.22
⇒D/B 10/2001	1.20
NON-SUSPENSION SEAT	1.12
OVERHEAD GUARD.....	1.8
SEMISUSPENSION SEAT	
SHEET 1 OF 2.....	1.14
SHEET 2 OF 2.....	1.16

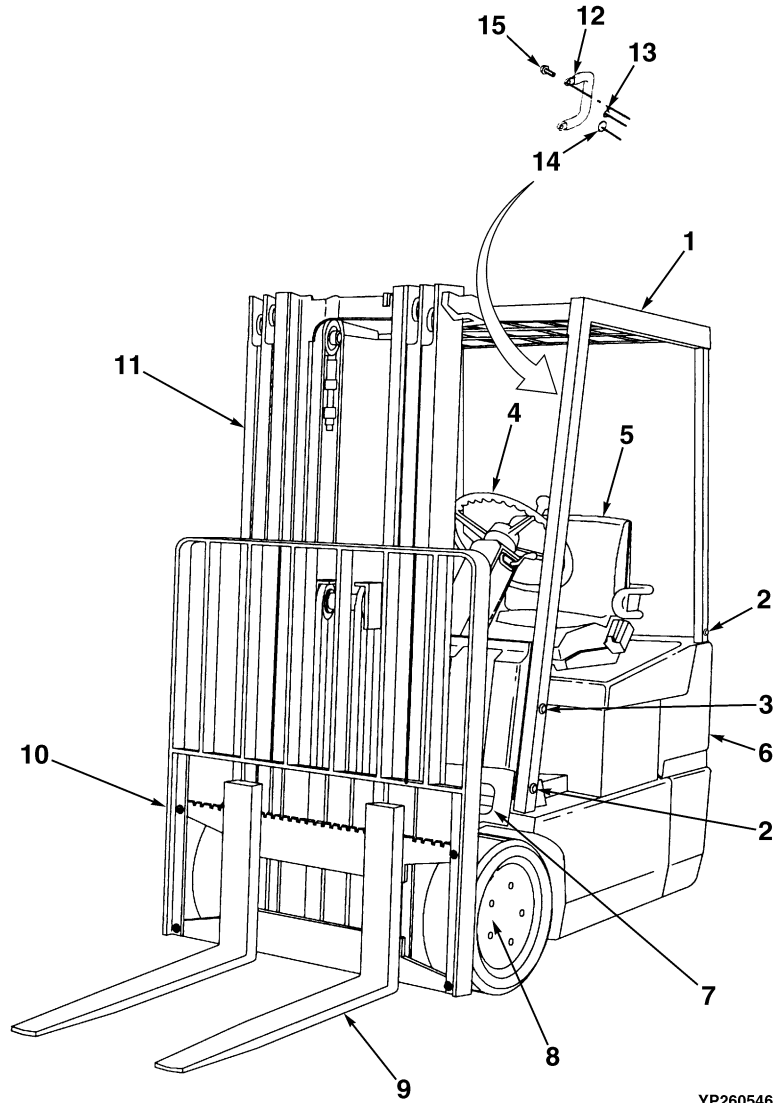

YP260546

ITEM	PART NO.	DESCRIPTION	QTY
1	a 520434807	Overhead Guard (1290 Wheel Base)	1
1	a 520434808	Overhead Guard (1385 Wheel Base)	1
1	b 524145293	Overhead Guard (1290 Wheel Base)	1
1	b 524145292	Overhead Guard (1385 Wheel Base)	1
2	449015029	Nut	4
2	501749902	Capscrew	4
2	504225227	Washer	8
3	449015029	Nut	6
3	501749902	Capscrew (RH)	1
3	504225227	Washer	4
3	505960578	Capscrew (LH)	1
4	Steering Wheel and Column (☞ Page 4.6)	1
5	Operator Seat (Non Suspension) (☞ Page 1.12)	1
5	Operator Seat (Suspension) (☞ Page 1.14)	1
6	505148700	Counterweight	1
7	502398907	Washer	2
7	580000195	Tilt Cylinder (5° Forward/7° Back)	2
7	580000197	Tilt Cylinder (10° Forward/5° Back)	2
8	Drive Unit Assembly (☞ Page 3.2)	1
9	Load Forks (☞ Page 1.22)	2
10	Load Backrest Extension (978 mm x 1219 mm High) (☞ Page 1.10)	1
11	Mast Assembly (Two Stage Limited Free-Lift) (☞ Page 7.2)	1
11	Mast Assembly (Two Stage Full Free-Lift) (☞ Page 9.2)	1
11	Mast Assembly (Three Stage Full Free-Lift) (☞ Page 8.2)	1
12	900001242	Handle	1
13	504230231	Screw	2
14	504241782	Plug	13
15	504241783	Plug	6

FOOTNOTES:

a ⇒ S/N D807A-04121Z

b S/N D807A-04122Z ⇒

BATTERY COMPARTMENT AND COVERS

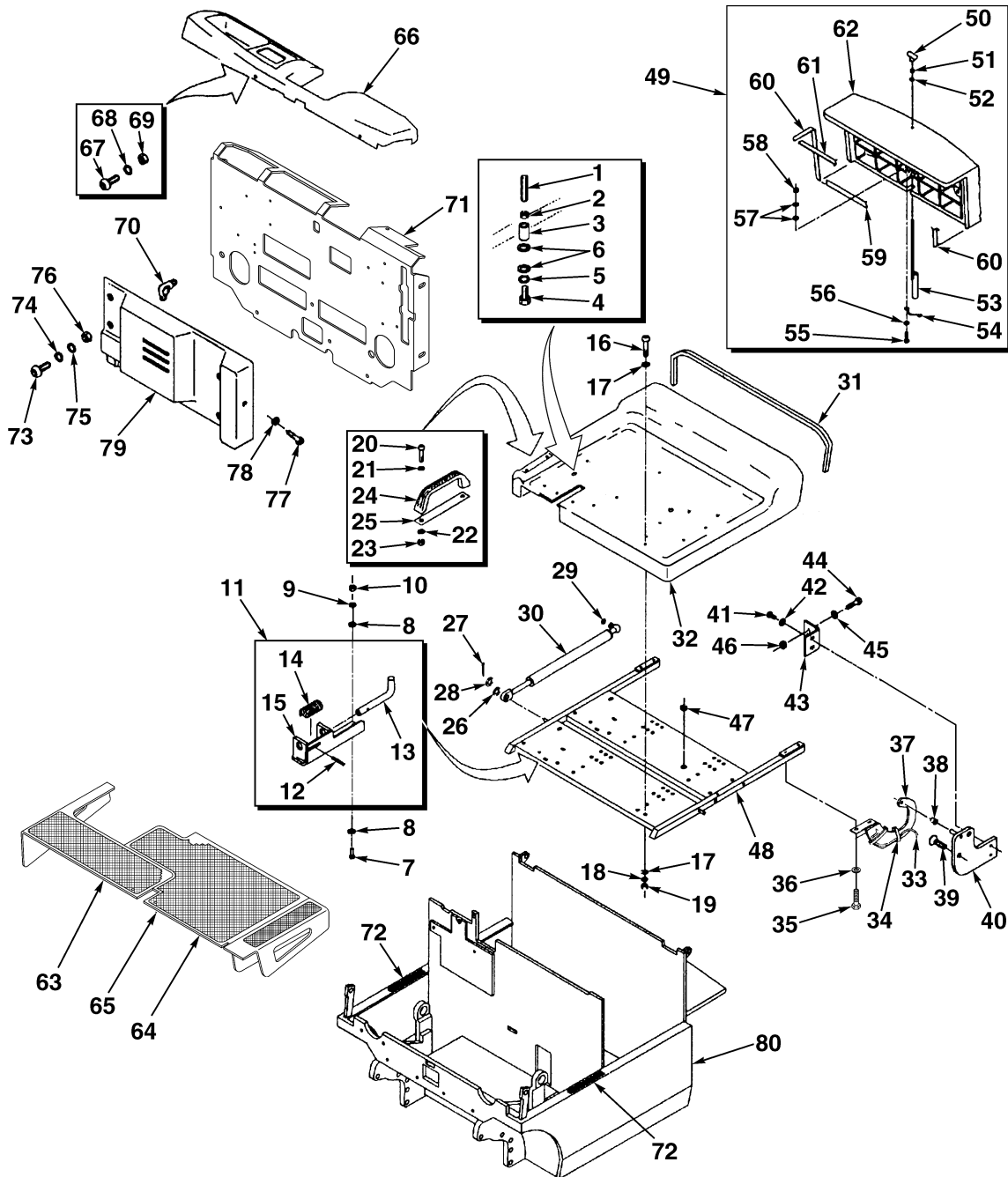

HP000222



BATTERY COMPARTMENT AND COVERS

ITEM	PART NO.	DESCRIPTION	QTY
1	504900200	Stud	1
2	014972900	Nut	1
3	504902200	Bushing	1
4	059079500	Capscrew	1
5	015026400	Lockwasher	1
6	502398906	Washer	2
7	449001014	Capscrew	2
8	449021001	Washer	4
9	449022016	Lockwasher	2
10	449015014	Nut	2
11	506713500	Latch	1
12	580012830	Pin	1
13	504851200	Pin	1
14	505008200	Spring	1
15	506655500	Guide	1
16	900014292	Capscrew	6
17	504226242	Washer	4
18	449022016	Lockwasher	5
19	519609804	Nut	5
20	449001272	Capscrew	2
21	449021003	Washer	2
22	449022018	Lockwasher	2
23	449015002	Nut	2
24	504235245	Handle	1
25	505139200	Plate	1
25	518807691	Plate (Optional).....	1
26	580001477	Spacer	2
27	015418200	Cotter Pin	2
28	504226242	Washer	2
29	449022016	Lockwasher	2
30	c 580013379	Gas Spring	2
30	b 580001466	Gas Spring	2
31	520035823	Seal	1
32	524137329	Battery Compartment Cover (1290 mm Wheel Base).....	1
32	524137328	Battery Compartment Cover (1385 mm Wheel Base).....	1
33	580011503	Wire Harness.....	1
34	312850034	Strap Clamp.....	1
35	449001415	Capscrew.....	4
36	449022016	Lockwasher	4
37	524135149	Hinge (RH).....	1
37	524135150	Hinge (LH)	1
38	502793901	Bearing	2
39	580001470	Bolt	4
40	524135153	Pivot (LH).....	1
40	524135154	Pivot (RH)	1
41	449001415	Capscrew.....	4
42	449022016	Lockwasher	4
43	580001477	Spacer	2
44	502512901	Screw (To Fit Cover 524135097).....	2
45	502398906	Washer (To Fit Cover 524135097).....	2

BATTERY COMPARTMENT AND COVERS

ITEM	PART NO.	DESCRIPTION	QTY
46	504236222	Nut (To Fit Cover 524135097)	2
47	519433637	Grommet.....	1
48	524137329	Battery Compartment Cover (1290 mm Wheel Base).....	1
48	524137299	Hood (1385 mm Wheel Base)	1
49	524135117	Cover Assembly.....	1
50	580001475	Knob.....	1
51	014970900	Nut.....	1
52	580001469	Grommet	1
53	524135182	Tow Pin.....	1
54	580001474	Retainer.....	1
55	580001471	Capscrew	2
56	449022018	Lockwasher	2
57	940102905	Lockwasher	6
58	449015002	Nut.....	2
59	520042874	Foam Tape	1
60	580001473	Seal Strip.....	2
61	580001472	Seal Strip.....	2
62	524135097	Cover.....	1
63	520350600	Floorplate (RH).....	1
64	520349600	Floorplate (LH)	1
64	a 524144246	Floorplate	1
65	520530600	Floormat	1
66	524138367	Cowl Cover	1
	524138368	Cowl Cover (With Seat Brake) (Includes Item)	1
67	449007018	Screw.....	4
68	449021003	Washer	2
69	449015002	Nut.....	2
70	013398000	Fitting.....	1
71	524138372	Cowl.....	1
71	524138373	Cowl (With Seat Brake)	1
72	506751500	Anti-Slip Pad.....	2
73	449007016	Screw.....	4
74	520082887	Washer	4
75	449021003	Washer	4
76	449015002	Nut.....	4
77	519432644	Screw.....	1
78	520082887	Washer	1
79	504590700	Cover (Front)	1
79	504918700	Cover (Front) (With Seat Brake)	1
80	524139403	Frame (1385 mm Wheel Base).....	1
80	524139402	Frame (1290 mm Wheel Base).....	1

FOOTNOTES:

- a** Cooling Fan Option
- b** ⇒ D/B 06/2000
- c** D/B 06/2000 ⇒

OVERHEAD GUARD

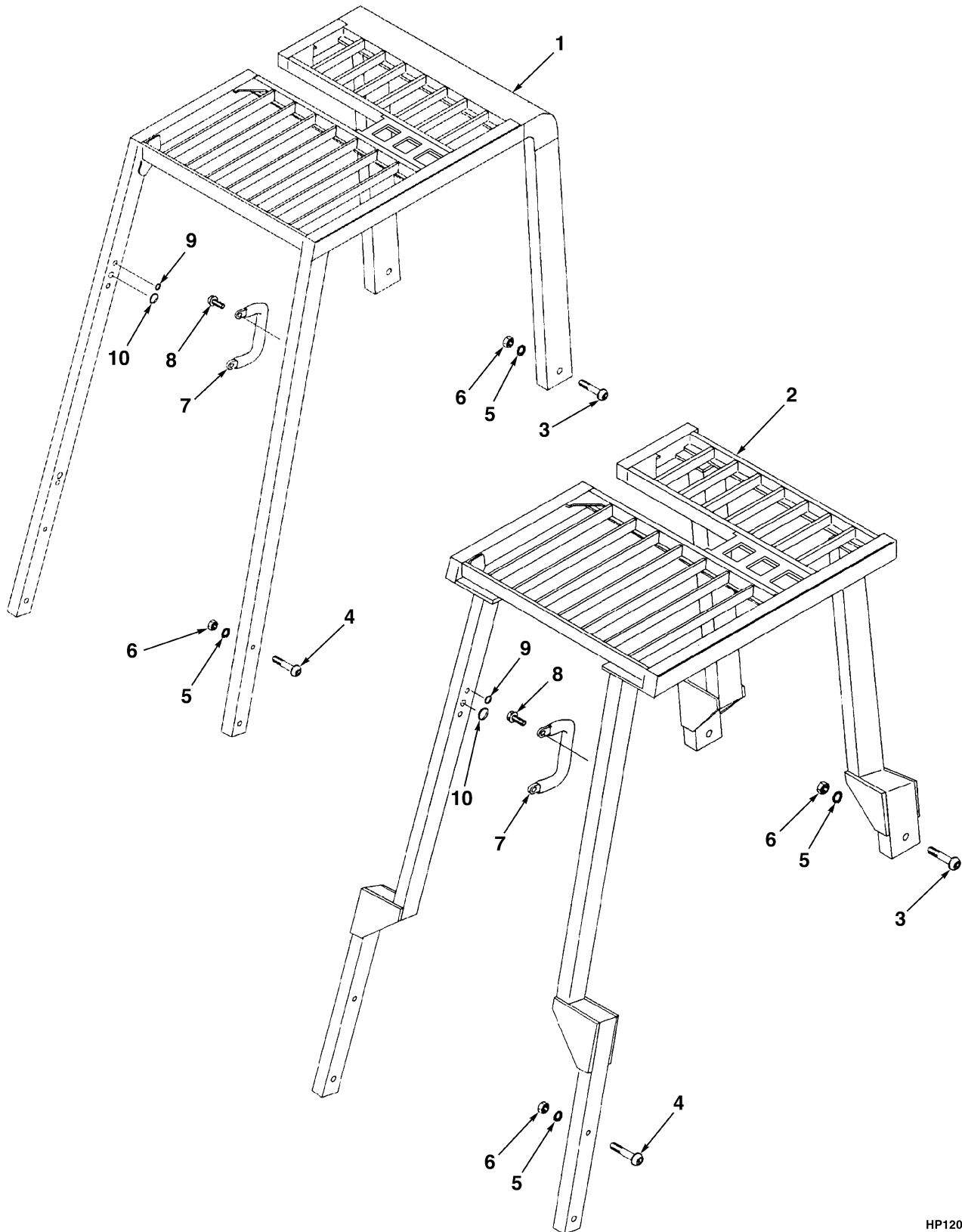

HP120522



OVERHEAD GUARD

KEY:

A: Standard

B: Drive-in Rack Option

ITEM	PART NO.	DESCRIPTION	QTY	
			A	B
1	a 520434807	Overhead Guard (1290 Wheel Base)	1	..
1	a 520434808	Overhead Guard (1385 Wheel Base)	1	..
1	b 524145293	Overhead Guard (1290 Wheel Base)	1	..
1	b 524145292	Overhead Guard (1385 Wheel Base)	1	..
2	524136991	Overhead Guard (1290 mm Wheel Base) (Raised)	1
2	524136992	Overhead Guard (1385 mm Wheel Base) (Raised)	1
3	501749902	Capscrew.....	5	5
4	505960578	Capscrew.....	1	1
4	502398907	Washer	2	2
5	449021010	Washer	12	12
6	449015029	Nut.....	6	6
7	900001242	Handle	1	1
8	504230231	Screw.....	2	2
9	504241782	Plug	13	15
10	504241783	Plug	7	7

FOOTNOTES:

a ⇒ S/N D807A-04121Z

b S/N D807A-04122Z ⇒

LOAD BACKREST

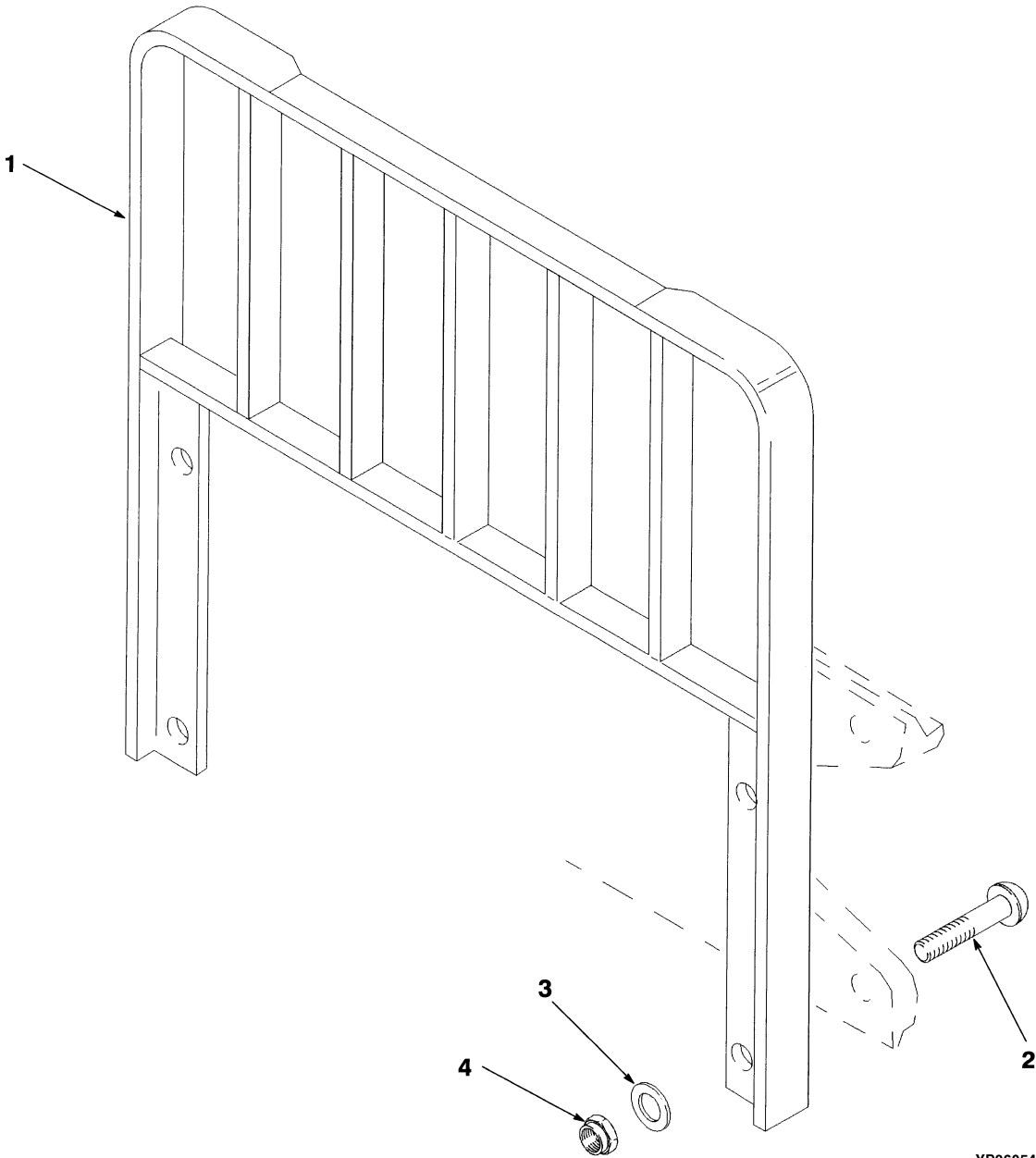

YP260548

ITEM	PART NO.	DESCRIPTION	QTY
1	504242751	Load Backrest Extension (977 mm)	1
2	501749902	Capscrew.....	4
3	061278200	Washer	4
3	504233271	Washer	4
	449022017	Lockwasher	4
4	580033885	Nut.....	4

NON-SUSPENSION SEAT

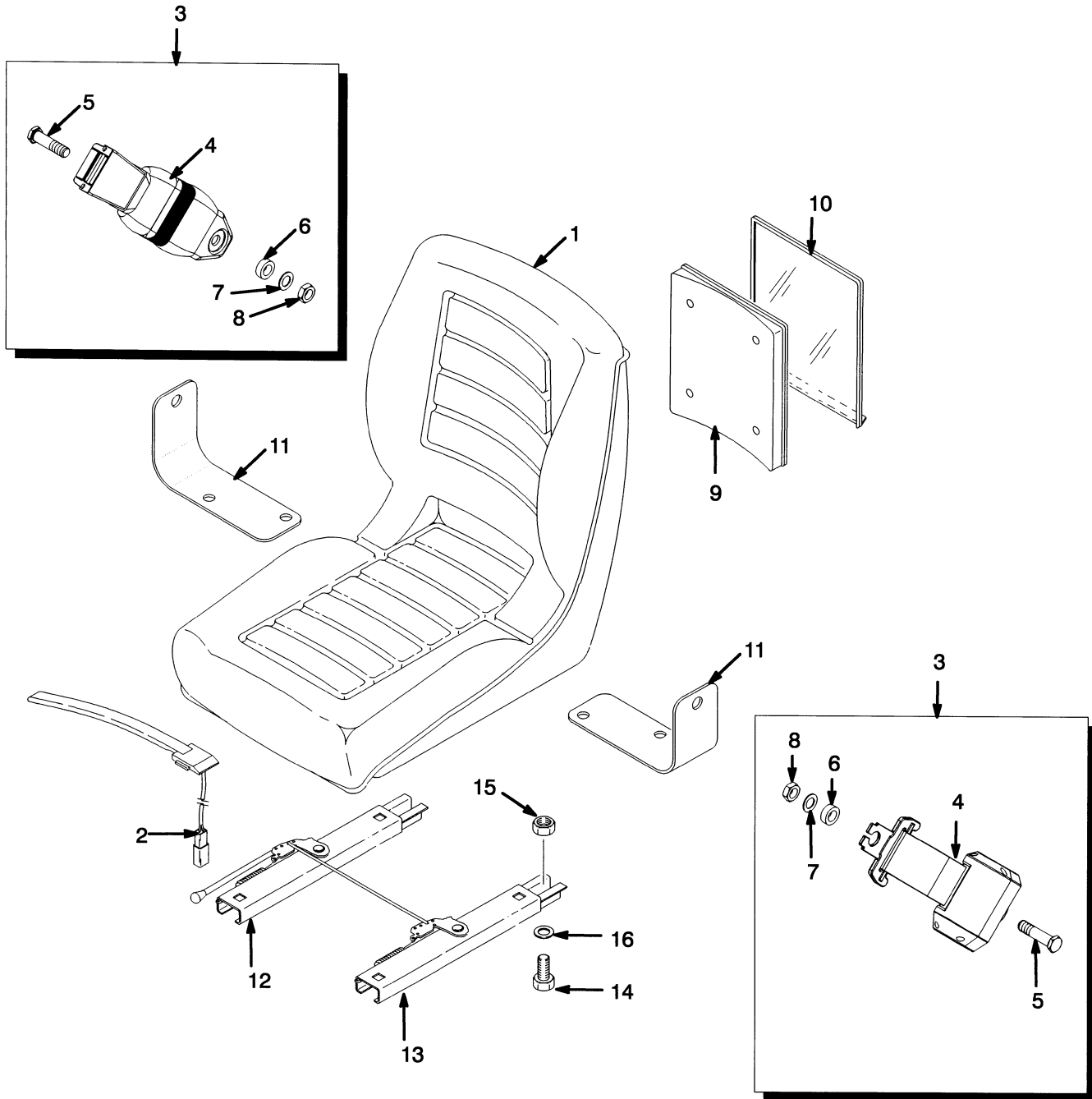

BP000036



Suggest:

For more complete manuals. Please go to the home page.

<https://www.ebooklibonline.com>

If the above button click is invalid. Please download this document first, and then click the above link to download the complete manual.

Thank you so much for reading

ITEM	PART NO.	DESCRIPTION	QTY
	580008424	Non-Suspension Seat.....	1
1	504232248	Seat.....	1
2	504305734	Switch Assembly	1
3	580010327	Seat Belt Kit	1
4	Seat Belt	1
5	Screw	2
6	Washer.....	2
7	Washer.....	2
8	Nut	2
9	519996801	Base	1
10	519996803	Cover.....	1
11	580014487	Bracket	1
12	580014485	Seat Rail.....	1
13	580014486	Seat Rail.....	1
14	059716300	Capscrew.....	4
15	504238298	Nut.....	4
16	023604600	Washer	4

SEMISUSPENSION SEAT (SHEET 1 OF 2)

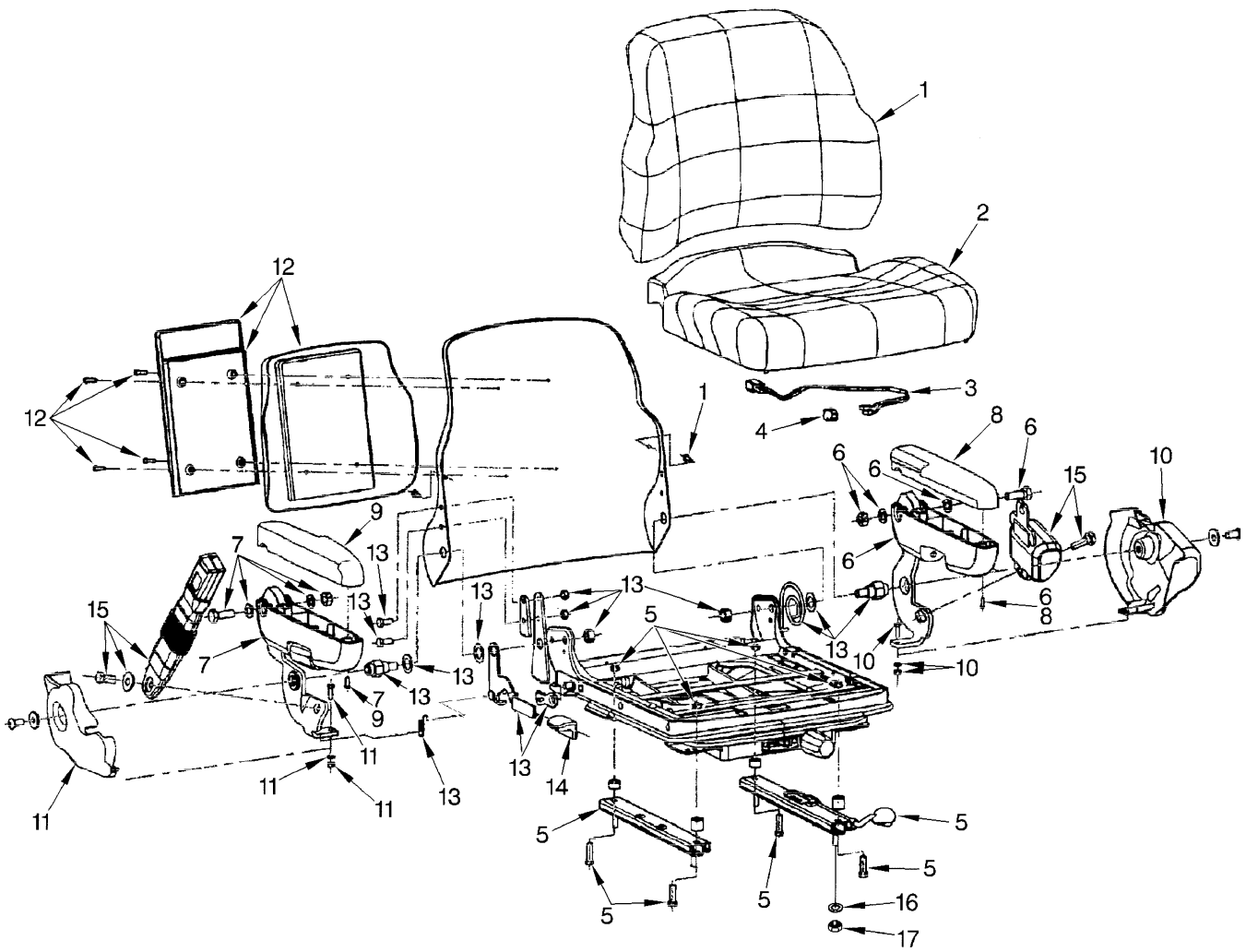

YP120121

<https://www.ebooklibonline.com>

Hello dear friend!

Thank you very much for reading.

Enter the link into your browser.

The full manual is available for immediate download.

<https://www.ebooklibonline.com>