

Parts Manual
Ersatzteilkatalog
Manuel des Pièces de Rechange
Catalogo Parti Ricambi
Manual de Repuestos

CE

T2500027

MO20

PART FIGURE INDEX / INDICE DELLE TAVOLE / INDEX DES TABLES /
 TAFELVERZEICHNIS / INDICE DE TABLAS

Part Figure index / <i>Indice delle tavole</i> / Index des tables / <i>Tafelverzeichnis</i> / Índice de tablas.....	page 2-3
Legend of symbols used in this handbook / <i>Legenda simbologia impiegata sul catalogo</i> / Legende symbolique utilisée sur catalogue / <i>Legende der Katalogsymbole</i> / Leyenda simbología empleada en el catálogo	page 4
How to use the handbook / <i>Uso del catalogo</i> / Utilisation du catalogue / <i>Nachschlagen des Katalogs</i> / Uso del catálogo	page 5
Fork carriage / <i>Spalliera</i> / Fourche / <i>Gabel</i> / Horquilla (FIG.1)	page 6-7
Frame -Foot board / <i>Telaio-Pedana</i> / Chassis-Plateforme / <i>Rahmen-Trittbrett</i> / Bastidor-Plataforma (FIG. 2)	page 8-9
Support and wheel / <i>Supporto e ruota</i> / Support et attelage / <i>Lagern und räder</i> / Soporte y rueda (FIG. 3).....	page 10-11
Drawbar control box / <i>Timone scatola comandi</i> / Barre boite de commande / <i>Deichsel steuerungsbuchse</i> / Dirección de mandos (FIG.4).....	page 12-13
Steering column / <i>Canotto sterzo</i> / Colonne direction / <i>Lenksäule</i> / Tubo dirección (FIG. 5)	page 14-15
Traction unit / <i>Gruppo trazione</i> / Groupe de traction / <i>Zugaggregat</i> / Grupo de tracción (FIG.6)	page 16-17
Traction motor / <i>Motore trazione</i> / Moteur de traction / <i>Zugmotor</i> / Motor de tracción (FIG.7).....	page 18-19
Hydraulic system / <i>Impianto idraulico</i> / Installation hydraulique / <i>Hydraulikanlage</i> / Instalación hidráulica (FIG.8).....	page 20-21
Lifting cylinder / <i>Cilindro di sollevamento</i> / Cylindre de soulèvement / <i>Hubzylinder</i> / Cilindro de elevación (FIG.9).....	page 22-23
Adhesive label / <i>Targhette e adesivi</i> / Autocollants de signalisation / <i>Selbstklebeschilder</i> / Tarjetas adhesivas (FIG.10)	page 24-25
Battery trucks (Option) / <i>Carrellino estrazione batteria (Optional)</i> / Chariot pour extraction batterie (Optionnel) / <i>Schlitten zur Batterieausnahme (Wahlfrei)</i> / Carro extracción batería (Opcional) (FIG.11)	page 26-27
Hydraulic diagram / <i>Schema oleodinamico</i> / Schéma hydraulique / <i>Hydraulikschaltplan</i> / Esquema oleodinámico (FIG.12).....	page 28-29
Power cables diagram / <i>Schema collegamenti cavi di potenza</i> / Diagramme liaison cable de puissance / <i>Elektrischeanlageplan</i> / Esquema conexión cable de potencia ((FIG.13).....	page 30-31
Sheath diagram / <i>Schema collegamenti guaine</i> / Diagramme liaison gaines / <i>Mantelanlageplan</i> / Esquema conexión vaina (FIG.14).....	page 32-33
Electronic diagram / <i>Schema elettronico</i> / Diagramme électronique / <i>Elektronikschaltplan</i> / Esquema electrónico (FIG.15) ..	page 34-35
Connectors, contacts, tools / <i>Contatti, connettori, utensili</i> / Connecteurs, contacts, outils / <i>Konnektors, kontakts, werkzeug</i> / Contacto, conector, utensilio (Fig.16)	page 36-37
Console adapter / <i>Adattatore per consolle</i> / Adaptateur pour console / <i>Adapteur für konsolle</i> / Adaptador pro consola Fig.17).....	page 38-39
Translation unit with steering (Option) / <i>Gruppo traslazione con sterzo (Optional)</i> / Groupe translation avec direction (Optionnel) / <i>Zugaggregat mit lenksäule (Wahlfrei)</i> / Grupo translación y dirección (Opcional) (FIG.18).....	page 40-41
Console with multi -turn steering (option) / <i>Console con guida a volantino (optional)</i>) / Ensemble consolle (Optionnel) / <i>satz-consolle (Wahlfrei)</i> / Grupo consola (Opcional) (FIG.19)	page 42-43
Console with return to center steering (option) / <i>Console con sterzo autocentrante (optional)</i> / Ensemble consolle (Optionnel) / <i>satz-consolle (Wahlfrei)</i> / Grupo consola (Opcional) (FIG.20).....	page 44-45
Steering wheel return to center potentiometer assembly (Option) / <i>Sterzo elettrico (Optional)</i> / Barre de direction électrique (Optionnel) / <i>elektrische steuerung (Wahlfrei)</i> / Manubrio eléctrico (Opcional) (FIG.20.1).....	page 46-47

PART FIGURE INDEX / INDICE DELLE TAVOLE / INDEX DES TABLES /
 TAFELVERZEICHNIS / INDICE DE TABLAS

Traction unit for guide with steering (Option) / Gruppo di trazione per guida con sterzo (Optional) / Groupe de traction pour guide avec direction (Optionnel) / Zugaggregat mit lenkung (Wahlfrei) / Grupo de tracción para guía y dirección (Opcional) (FIG.21).....	page 48-49
Power cables diagram with steering (Option) / Schema collegamenti cavi di potenza con sterzo (Optional) / Diagramme liaison cable de puissance / Elektrischeanlageplan / Esquema conexión cable de potencia (FIG.22).....	page 50-51
Electrical cables with steering (Option) / Cavi elettrici con sterzo (Optional) / Cables électriques pour avec direction (Optionnel) / Elektrische kabel mit lenkung (Wahlfrei) / Cable eléctrico por y dirección (Opcional) (FIG.23).....	page 52-53
Electronic diagram with steering (Option) / Schema elettronico con sterzo (Optional) / Schéma électronique per avec direction (Optionnel) / Elektronischaltplan mit lenkung (Wahlfrei) / Esquema electrónico y dirección (Opcional) (FIG.24).....	page 54-55
Picking note holder unit (Option) / Gruppo leggìo (Optional) / Groupe pupitre (Optionnel) / Leichterschiff (Wahlfrei) / Grupo atril (Opcional) (FIG.25).....	page 56-57
Supplementary protections (Option) / Protezioni supplementari (Optional) / Protection supplémentaire (Optionnel) / Schutz (Wahlfrei) / Protección suplementario (Opcional) (FIG.26).....	page 58-59
Pallet carriage MO20/F (Option) / Spalliera pallet MO20/F (Optional) / Espalier pallet MO20/F (Optionnel) / Paletten-auflage MO20/F (Wahlfrei) / Pared lateral pallet MO20/F (Opcional) (FIG. 27).....	page 60-61
Rocker plate ass'y MO20/F (Option) / Ass. bilancino MO20/F (Optional) / Ens. palonnier MO20/F (Optionnel) / Satz-pendeldurchgangsplatte MO20/F (Wahlfrei) / Balancín MO20/F (Opcional) (FIG.28).....	page 62-63
Forks lifting cylinder MO20/F (Option) / Cilindro sollevamento forche MO20/F (Optional) / Cylindre de soulevement fourches MO20/F (Optionnel) / Hubzylinder der gabeln MO20/F (Wahlfrei) / Cilindro de elevación horquillas MO20/F (Opcional) (FIG.29).....	page 64-65
General index / Indice generale / Index général / Generalindex / Indice general	page 66-67
Note / Note / Note / Hinweise / Notas	page 68-69

<https://www.ebooklibonline.com>

Hello dear friend!

Thank you very much for reading.

Enter the link into your browser.

The full manual is available for immediate download.

<https://www.ebooklibonline.com>

LEGEND OF SYMBOLS USED IN THIS HANDBOOK / *LEGENDA SIMBOLOGIA IMPIEGATA SUL CATALOGO* / *LEGENDE SYMBOLIQUE UTILISÉE SUR CATALOGUE* / *LEGENDE DER KATALOGSYMBOLE* / *LEYENDA SIMBOLOGÍA EMPLEADA EN EL CATÁLOGO*

◆ Optional / *Optional* / *Optionnel* / *Wahlfrei* / Opcional

* Seals kit / *Kit guarnizioni* / *Kit joints* / *Dichtungssatz* / *Kit de guarniciones*

■ Item fitted on models with forks L=1000-1150mm and on models United Kingdom with forks L=1950-2150-2350mm /

Particolare presente solo nei mod. con forche L=mm1000-1150 e nei modelli United Kingdom con forche L=mm1950-2150-2350 /

Détail présent seulement pour les modeles avec fourches L=mm1000-1150 et pour les modeles United Kingdom avec fourches L=mm1950-2150-2350 /

Einzelteil nur an Gabel-Modellen vorhanden L=mm1000-1150 ; Einzelteil nur an Gabel-Modellen vorhanden L=mm1950-2150-2350 (United Kingdom) /

Detalle presente solamente en los modelos con horquillas L=mm1000-1150 y en los modelos United Kingdom con horquillas L=mm1950-2150-2350

Item fitted on models for refrigerating rooms (- 30°C) / *Particolare presente solo nei modelli per celle frigorifere (- 30°C) /*

* Détail présent seulement pour les modeles pour cellules à glace (- 30°C) /

Dieser Bestandteil befindet sich nur in Modellen für Eiskammer (- 30°) /

Detalle presente solamente en los modelos para cámara de refrigeración (- 30°C)

HOW TO USE THE HANDBOOK / USO DEL CATALOGO / UTILISATION DU CATALOGUE / NACHSCHLAGEN DES KATALOG / USO DEL CATÁLOGO

Specify the following information when ordering spare parts:
Per ordinare parti di ricambio specificare:
 Pour les commander les pièces détachées veuillez préciser:
Zum Bestellen von Ersatzteilen bitte folgende Angaben machen:
 Para solicitar los repuestos especificar:

- truck model
- *tipo della macchina*
- type machine
- *Staplertyp*
- tipo de la máquina.

- table N°
- *N° della tavola*
- N° plan
- *Tafel-Nr.*
- N° de la máquina.

- quantity
- *quantità dei particolari richiesti*
- nombre de pièces
- *Erforderliche Stückzahl*
- cantidad de piezas solicitadas.

Model	MO20
Serial number	C857T01501X
 <small>T2500027</small>	

ARD	FIGURE 1
Description	
Seeger Bearing	

	Q.ty	Descri
7000	4	Seeg
5700	4	Bearin
4700	4	Washes
3400	14	Grease

MO20	C857T01501X	FIGURE 1	273005700	4	Bearing
-------------	--------------------	-----------------	------------------	----------	----------------

Model	MO20
Serial number	C857T01501X
 <small>T2500027</small>	

em	Part N°
2	273087000
3	273005700
4	273104700
5	273033400

Q.ty	Description
4	Seeger
4	Bearing
4	Washer
14	Grease ftg.

- truck serial number
- *matricola della macchina*
- N° matricule
- *Seriennummer der Maschine*
- matrícula de la máquina.

- part number of required component
- *N° di codice del particolare richiesto*
- N° code de la pièce
- *Best. Nr. des erforderlichen Teils*
- N° de código de la pieza solicitada.

- part description
- *demoninazione del particolare richiesto*
- désignation de la pièce
- *Bezeichnung des erforderlichen Teils*
- denominación de la pieza solicitada.

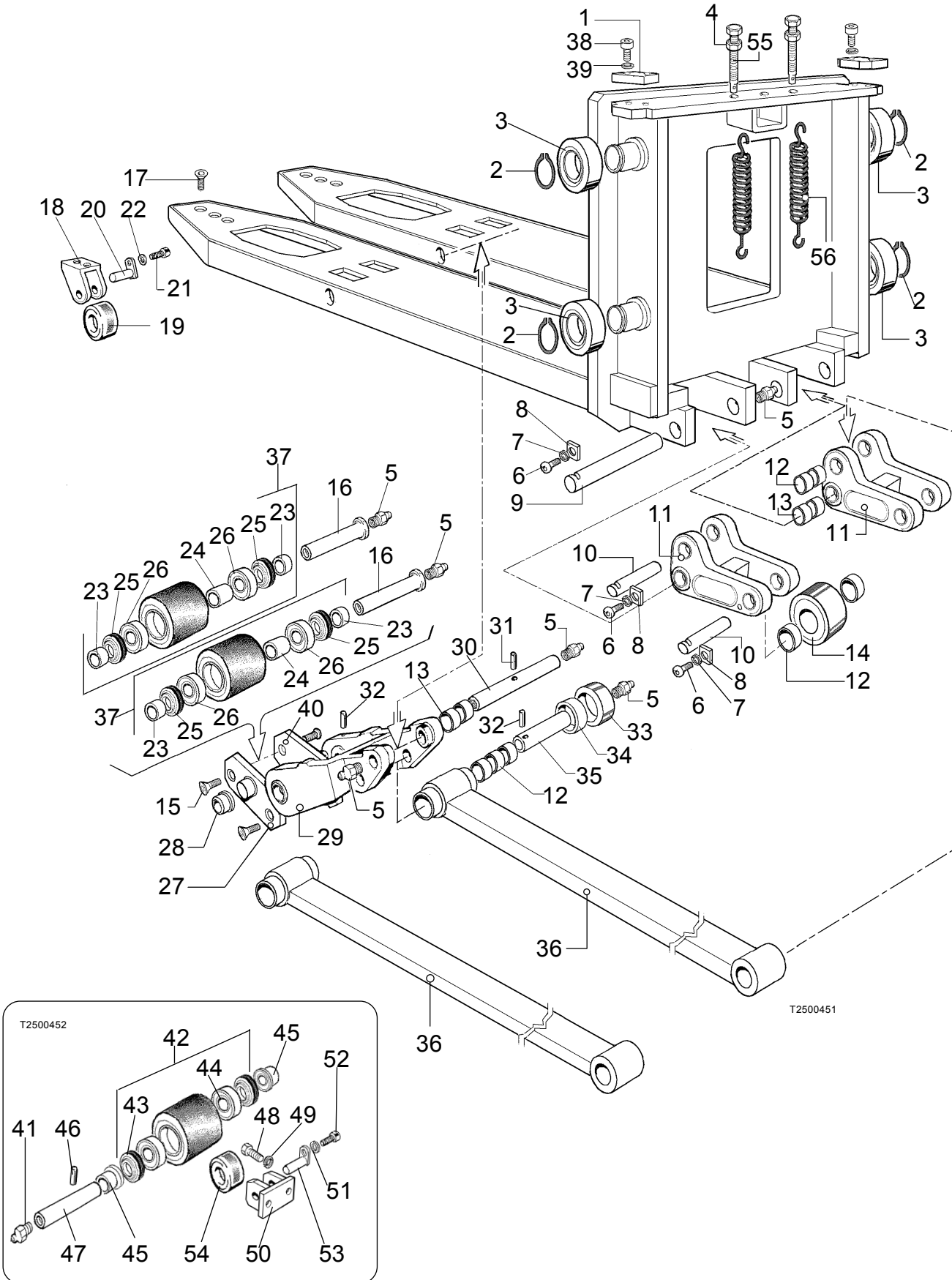

FORK CARRIAGE / SPALLIERA / FOURCHE / GABEL / HORQUILLA

FIGURE 1

REF.	PART NO.	Q.TY	DESCRIPTION	DESCRIZIONE	DESIGNATION	BENENNUNG	DENOMINACIONES
1	273054200	2	Nylon guide	Pattini di guida	Guide en nylon	Führungsschieber	Patines guía
2	273087000	4	Seeger	Seeger	Arretoi	Seeger-Ring	Seeger
3	273005700	4	Bearing	Cuscinetto	Roulement	Lager	Cojinete
4	273104700	4	Washer	Rondella	Rondelle	Unterlegscheibe	Arandela
5	273033400	14	Grease fig.	Ingrassatore	Graisseur	Schmiernippel	Engrasador
6	449001415	6	Screw	Vite	Vis	Schraube	Tornillo
7	449022016	6	Lock washer	Rosetta elastica	Rondelle souple	Federscheibe	Arandela elástica
8	273059700	6	Plate	Piatto	Plaque	Teller	Plato
9	273047100	2	Axle	Perno	Axe	Bolzen	Perno
10	273015800	4	Axle	Perno	Axe	Bolzen	Perno
11	273046900	2	Lever	Leva	Levier	Hebel	Palanca
12	273032800	14	Bush	Boccola	Douille	Buchse	Buje
13	273011400	8	Bush	Boccola	Douille	Buchse	Buje
14	277457400	2	Adjust roller	Rullo regolazione	Rouleau	Stellrad	Perilla de regulac.
15	580001470	4	Screw	Vite	Vis	Schraube	Tornillo
16	273002800	4	Axle	Perno	Axe	Bolzen	Perno
■ 17	900010217	4	Screw	Vite	Vis	Schraube	Tornillo
■ 18	273045900	2	Support	Supporto	Support	Halter	Soporte
■ 19	273045600	2	Lead-in roller	Rullo d'invito	Rouleau	Einfuhrrolle	Rodillo de invitac.
■ 20	273002600	2	Axle	Perno	Axe	Bolzen	Perno
■ 21	580006762	2	Screw	Vite	Vis	Schraube	Tornillo
■ 22	449022016	2	Lock washer	Rosetta elastica	Rondelle souple	Federscheibe	Arandela elástica
23	273091000	2	Spacer	Distanziale	Entretoise	Distanzstück	Espaciador
24	273090900	1	Spacer	Distanziale	Entretoise	Distanzstück	Espaciador
25	273065500	2	Washer and seal	Anelli di protezione	Bagues de protect.	Sicherungsringe	Anillos de protec.
26	273005500	2	Bearing	Cuscinetto	Roulement	Lager	Cojinete
27	273017600	2	Counter. rocker plate	Bilancino svasato	Palonnier	Pendelbecher	Balancin vaciado
28	273010300	4	Bush	Boccola	Douille	Buchse	Buje
29	273015700	2	Connecting link	Biella	Bielle	Pleuel	Biela
30	273031300	2	Axle	Perno	Axe	Bolzen	Perno
31	449034085	2	Elastic pin	Spina elastica	Goupille élastique	Federstift	Enchufe elástico
32	277465900	4	Elastic pin	Spina elastica	Goupille élastique	Federstift	Enchufe elástico
33	273045700	2	Lead-in roller	Rullo d'invito	Rouleau	Einfuhrrolle	Rodillo de invitac.
34	277362700	2	Bush	Boccola	Douille	Buchse	Buje
35	273097700	2	Axle	Perno	Axe	Bolzen	Perno
36	273098600	2	Tie rod (forks L=mm 1000)	Tirante (forche L=mm 1000)	Tirant (fourches L=mm 1000)	Zugstange (Gabeln L=mm 1000)	Tirante (horquillas L=mm 1000)
36	277469300	2	Tie rod (forks L=mm 1150/1400/ 1600)	Tirante (forche L=mm 1150/1400/ 1600)	Tirant (fourches L=mm 1150/1400/ 1600)	Zugstange (Gabeln L=mm 1150/1400/ 1600)	Tirante (horquillas L=mm 1150/1400/ 1600)
36	277457200	2	Tie rod (forks L=mm 1950/2150/ 2350C)	Tirante (forche L=mm 1950/2150/ 2350C)	Tirant (fourches L=mm 1950/2150/ 2350C)	Zugstange (Gabeln L=mm 1950/2150/ 2350C)	Tirante (horquillas L=mm 1950/2150/ 2350C)
36	277469400	2	Tie rod (forks L=mm 2350 / 2850)	Tirante (forche L=mm 2350 / 2850)	Tirant (fourches L=mm 2350 / 2850)	Zugstange (Gabeln L=mm 2350 / 2850)	Tirante (horquillas L=mm 2350 / 2850)
36	277780600	2	Tie rod (forks L=mm 1950/2150 United Kingdom)	Tirante (forche L=mm 1950/2150 United Kingdom)	Tirant (fourches L=mm 1950/2150 United Kingdom)	Zugstange (Gabeln L=mm 1950/2150 United Kingdom)	Tirante (horquillas L=mm 1950/2150 United Kingdom)
36	277780700	2	Tie rod (forks L=mm 2350 United Kingdom)	Tirante (forche L=mm 2350 United Kingdom)	Tirant (fourches L=mm 2350 United Kingdom)	Zugstange (Gabeln L=mm 2350 United Kingdom)	Tirante (horquillas L=mm 2350 United Kingdom)
37	273062500	4	Polyur. wheel ass'y	Ass. rullo adiprene	Ens. roue vullollan	Satz Adipren-Rolle	Eje rodillo poliur.
38	449002142	5	Screw	Vite	Vis	Schraube	Tornillo
39	449021006	4	Washer	Rosetta	Rondelle	Unterlegscheibe	Arandela
40	273098100	2	Through rocker plate	Bilancino passante	Palonnier	Pendeldurchgangsplatte	Balancin pasante
◆ 41	273033400	2	Grease fig.	Ingrassatore	Graisseur	Schmiernippel	Engrasador
◆ 42	273061100	2	Polyuret. wheel ass'y	Ass. rullo adiprene	Ens. roue vullollan	Satz Adipren-Rolle	Eje rodillo poliuret.
◆ 43	273065500	2	Washer and seal	Anelli di protezione	Bagues de protect.	Schutzringe	Anillos de protec.
◆ 44	273005500	2	Bearing	Cuscinetto	Roulement	Lager	Cojinete
◆ 45	273090800	4	Spacer	Distanziale	Entretoise	Distanzstück	Separador
◆ 46	277465900	2	Elastic pin	Spina elastica	Goupille élastique	Federstift	Enchufe elástico
◆ 47	273002700	2	Axle	Perno	Axe	Bolzen	Perno
◆ 48	504239239	2	Screw	Vite	Vis	Schraube	Tornillo
◆ 49	449022016	2	Lock washer	Rosetta elastica	Rondelle souple	Federring	Arandela elástica
◆ 50	273046000	2	Support	Supporto	Support	Lager	Soporte
◆ 51	449022016	2	Lock washer	Rosetta elastica	Rondelle souple	Federring	Arandela elástica
◆ 52	580006762	2	Screw	Vite	Vis	Schraube	Tornillo
◆ 53	273002600	2	Axle	Perno	Axe	Bolzen	Perno
◆ 54	273045800	2	Lead-in roller	Rullo d'invito	Rouleau	Einfuhrrolle	Rodillo de invitac.
55	273073200	2	Screw	Vite	Vis	Schraube	Tornillo
56	273093600	2	Spring	Molla	Ressort	Feder	Resorte

 From serial N° / Da matr. /
 Du matr. / Ab. seriennummer /
 Desde la matr. :

 Until serial N° / Fino a matr. /
 Jusq' matr. / Bis zur serien-Nr. /
 Hasta la matr. :

 With the exception of /
 Ad esclusione di / À l'exclusion de
 / Mit ausnahme von / Excepto :

 Including / Compreso / Avec /
 Einschließlich / Con :

C857T01501X

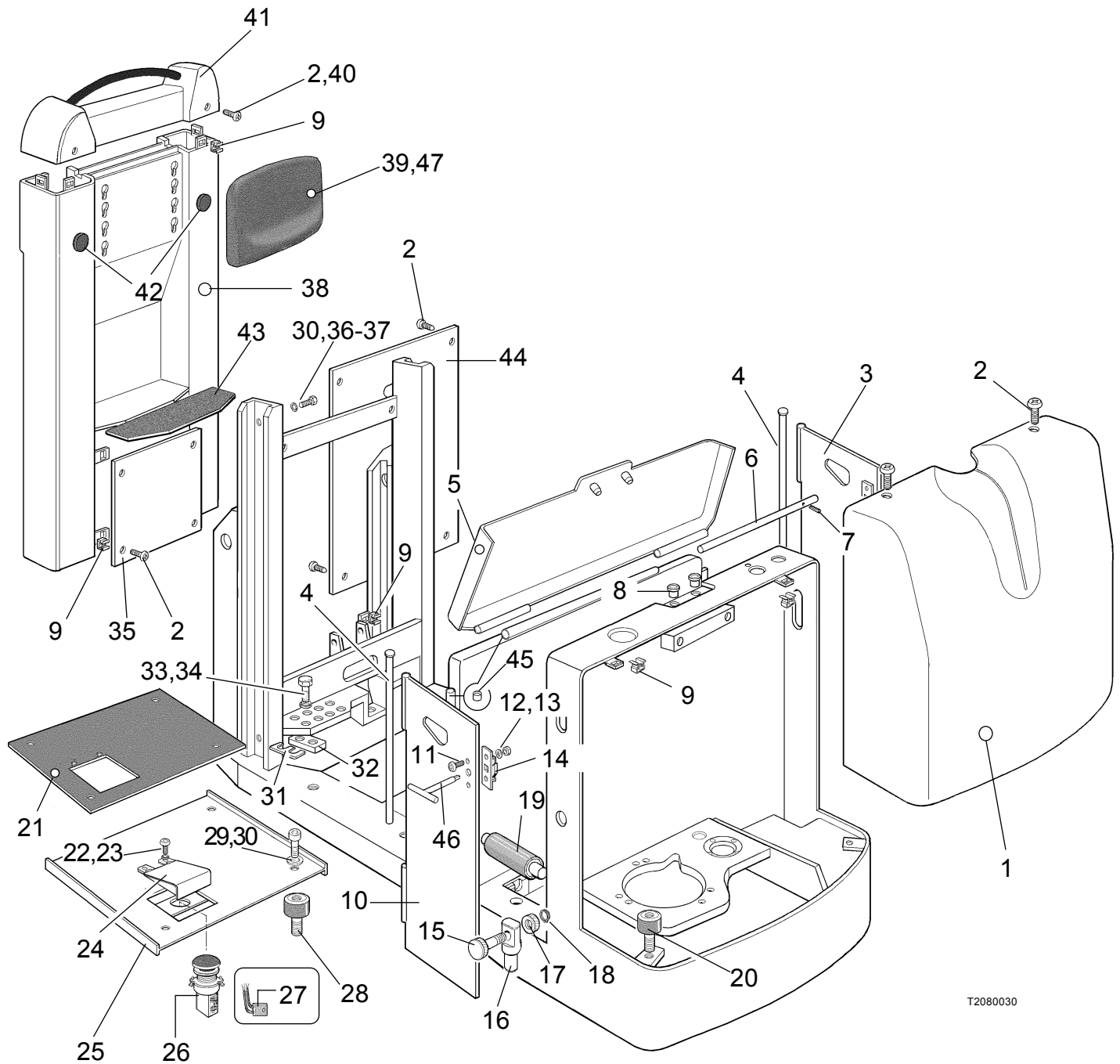

T2080030



Suggest:

For more complete manuals. Please go to the home page.

<https://www.ebooklibonline.com>

If the above button click is invalid. Please download this document first, and then click the above link to download the complete manual.

Thank you so much for reading

REF.	PART NO.	Q.TY	DESCRIPTION	DESCRIZIONE	DESIGNATION	BENENNUNG	DENOMINACIONES
1	277458700	1	Hood	Cofano	Capot	Haube	Capot
2	518791613	14	Screw	Vite	Vis	Schraube	Tomillo
3	524144719	1	Left door	Portina sinistra	Guichet gauche	Linke Tür	Portez. izquierda
4	580023635	2	Shaft	Perno	Axe	Stift	Perno
5	524144718	1	Battery cover	Coperchio batteria	Couvercle batterie	Batteriedeckel	Cubierta batería
6	580023636	1	Shaft	Perno coperchio	Axe	Stift	Perno
7	449034077	1	Elastic pin	Spina elastica	Goupille élastique	Federstift	Enchufe elástico
8	580023634	2	Centering pin	Gommini centraggio	Antivibrant	Schwingungsdamp	Antivibrador
9	272342200	14	Nut	Dado	Écrou	Mutter	Tuerca
10	524144720	1	Right door	Portina destra	Guichet droite	Rechte Tür	Portez. derecha
11	505975518	4	Screw	Vite	Vis	Schraube	Tomillo
12	449021002	4	Washer	Rondella	Rondelle	Unterlegscheibe	Arandela
13	449015112	4	Self locking nut	Dado autobloccante	Écrou	Mutter	Tuerca
14	277780400	2	Latch	Serratura	Serrure	Schloß	Cerradura
15	273084100	2	Screw	Vite fermo batteria	Vis	Schraube	Tomillo
16	273095900	2	Support	Supporto	Support	Lager	Soporte
17	273101900	2	Washer	Rondella	Rondelle	Unterlegscheibe	Arandela
18	273087700	2	Snap ring	Seeger	Arretoi	Seeger	Anillo seeger
19	273070600	3	Roller	Rullo batteria	Galet	Rolle	Rodillo
20	273101200	2	Vibration damper	Antivibrante	Antivibrateur	Vibrationsdämpfer	Antivibrante
21	580023637	1	Floor mat	Tappeto	Tapis caoutchouch	Alfombra	Tappeto
22	932727901	4	Screw	Vite	Vis	Schraube	Tomillo
23	449021002	4	Washer	Rondella	Rondelle	Unterlegscheibe	Arandela
24	580021765	1	Pedal	Pedale	Pedal	Fusshebel	Pedal
25	524144428	1	Foot board	Pedana	Plateforme	Trittbrett	Plateforma
26	273012100	1	Button	Pulsante	Bouton	Taste	Pulsante
* 27	277270000	3	Resistor (-30°)	Resistenza (-30°)	Resitance (-30°)	Widerstand (-30°)	Resistencia (-30°)
28	273101200	4	Vibration damper	Antivibrante	Antivibrateur	Vibrationsdämpfer	Antivibrante
29	580022963	4	Screw	Vite	Vis	Schraube	Tomillo
30	449022016	4	Lock washer	Rosetta elastica	Rondelle souple	Federring	Arandela elástica
31	277457500	4	Spacer	Spessore	Entretoise	Abstandhalter	Separador
32	277457600	2	Roller slide way	Blocchetto appoggio rullo	Arrêt	Block	Bloque
33	449022013	4	Lock washer	Rosetta elastica	Rondelle souple	Federring	Arandela elástica
34	580022965	4	Screw	Vite	Vis	Schraube	Tomillo
35	524144685	1	Front plate	Pannello anteriore	Panneau	Tafel	Talero
36	449001013	1	Screw	Vite	Vis	Schraube	Tomillo
37	449021001	1	Lock washer	Rosetta elastica	Rondelle souple	Federring	Arandela elástica
38	524144429	1	Protection	Protezione	Protection	Schutz	Protección
39	277459000	1	Back rest	Schienale	Dossier	Rückenlehne	Rückenlehne
40	449021003	14	Washer	Rondella	Rondelle	Unterlegscheibe	Arandela
41	524144460	1	Top closing	Chiusura superiore	Fermeture supér.	obere Verschuß	Cierre superior
42	277468000	2	Button	Pulsante	Bouton	Taste	Pulsante
43	277460400	1	Floor mat	Tappeto	Tapis caoutchouch	Alfombra	Tappeto
44	524144684	1	Raer panel	Pannello posteriore	Panneau	Tafel	Tablero
45	273010700	AR	Bushing-Glacier	Boccola	Douille	Buchse	Buje
46	580019997	1	Key	Chiave	Clavette	Schlüssel	Claveta
47	900014292	2	Screw	Vite	Vis	Schraube	Tomillo

 From serial N° / Da matr. /
 Du matr. / Ab. seriennummer /
 Desde la matr. :

 Until serial N° / Fino a matr. /
 Jusq' matr. / Bis zur serien-Nr. /
 Hasta la matr. :

 With the exception of /
 Ad esclusione di / À l'exclusion de
 / Mit ausnahme von / Excepto :

 Including / Compreso / Avec /
 Einschließlich / Con :

C857T01501X

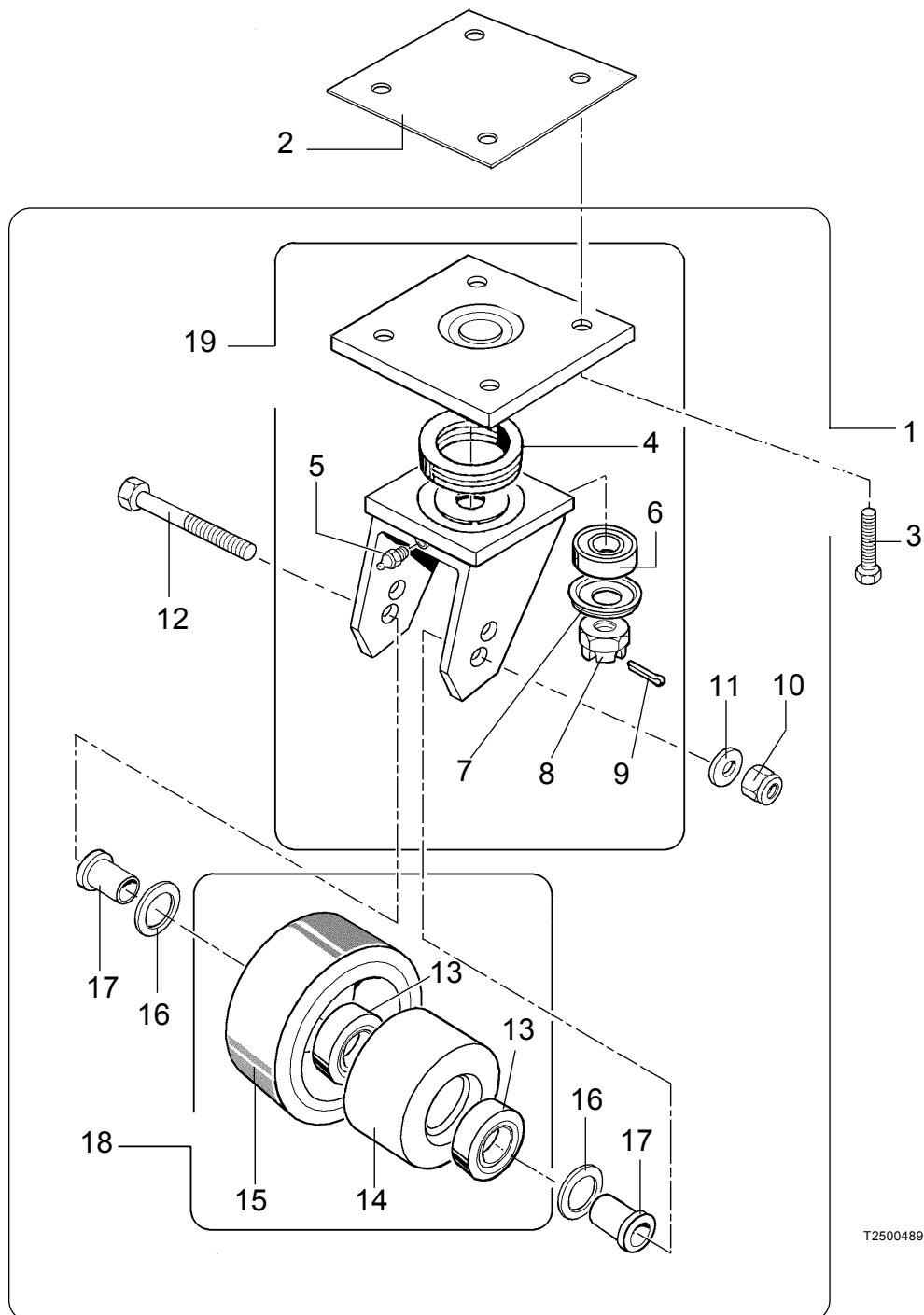

<https://www.ebooklibonline.com>

Hello dear friend!

Thank you very much for reading.

Enter the link into your browser.

The full manual is available for immediate download.

<https://www.ebooklibonline.com>