

Parts Manual

Elenco Ricambi

Part No: **524187172 (03/2003)**

Manuel des Pièces de Rechange

Ersatzteilkatalog

Manual de Repuestos

CE

MP25HD

MP30HD

Yale  **L**

Specify the following information when ordering spare parts: Zum Bestellen von Ersatzteilen bitte folgende Angaben machen:

- **truck model;**
- truck serial number;
- **table N°;**
- *part number of required component;*
- **quantity;**
- *part description*

- **Staplertyp;**
- Seriennummer der Maschine;
- **Tafel-Nr.;**
- *Best. Nr. des erforderlichen Teils;*
- **Erforderliche Stückzahl;**
- *Bezeichnung des erforderlichen Teils.*

Per ordinare parti di ricambio specificare:

- **tipo della macchina;**
- *matricola della macchina;*
- **n° della tavola;**
- *numero di codice del particolare richiesto;*
- **quantità di particolari richiesti;**
- *denominazione del particolare richiesto.*

Para solicitar los repuestos especificar:

- **tipo de la máquina;**
- *matrícula de la máquina;*
- **n° de la máquina;**
- *número de código de la pieza solicitada;*
- **cantidad de piezas solicitadas;**
- *denominación de la pieza solicitada.*

Pour les commander les pièces détachées veuillez préciser:

- **type machine;**
- *n° matricule;*
- **n° plan;**
- *n° code de la pièce;*
- **nombre de pièces;**
- *désignation de la pièce.*

PART SHEET INDEX - INDICE DELLE TAVOLE - INDEX DES TABLES - TAFELVERZEICHNIS - INDICE DE TABLAS	PAGE NO.
COVERS / CARTER / COUVERCLE / DECKEL / TAPAS (SHEET 1.A)	4-5
ADHESIVE LABELS / TARGHETTE ADESIVE / AUTOCOLLANTS DE SIGNALISATION / ABZ.-BILD / ADESIVOS DE AVISO (SHEET 2.A)	6-7
FRAME BATTERY VERTICAL REMOVAL / TELAIO BATTERIA ESTRAZIONE VERTICALE / CHASSIS BATTERIE VERTICAL EXTRACTION / BATTERIEWECHSEL KONVENTIONELLE BATTERIE ENDHAME / BASTIDOR BATERIA EXTRACCION VERTICAL (SHEET 3.A)	8
FRAME BATTERY LATERAL REMOVAL / TELAIO BATTERIA ESTRAZIONE LATERALE / CHASSIS BATTERIE LATERAL EXTRACTION / BATTERIEWECHSEL SEITLICHER / BASTIDOR BATERIA EXTRACCION LATERAL (SHEET 4.A)	9
SUPPORTS AND CASTER WHEELS / SUPPORTI E RUOTE PIROETTANTI / SUPPORTS ET ATTELAGE / LAGERN UND RÄDER / SOPORTE Y RUEDAS (SHEET 5.A)	10-11
STRUCTURE / STRUTTURA / STRUCTURE / GESTELL / ESTRUCTURA (SHEET 6.A)	12-13
STRUCTURE FOIR COILS / STRUTTURA PER BOBINE / STRUCTURE POUR BOBINA / GESTELL SPULE / ESTRUCTURA BOBINA(SHEET 7.A)	14-15
FORKS / FORCHE / FOURCHES / FORKE / HORCAS (SHEET 8.A)	16-17
TRACTION UNIT / GRUPPO TRAZIONE / GROUPE DE TRACTION / ZUGAGGREGAT / GRUPO DE TRACCION (SHEET 9.A)	18-19
TRACTION MOTOR / MOTORE TRAZIONE / MOTEUR TRACTION / ZUGMOTOR / MOTORE DE TRACCION (SHEET 10.A)	20-21
MAGNETIC BRAKE / FRENO ELETTROMAGNETICO / FREIN ELETTROMAGN. / ELEKT ROMAGN. BREMSE / FRENO ELECTROM.(SHEET 11.A)	22-23

PART SHEET INDEX - INDICE DELLE TAVOLE - INDEX DES TABLES - TAFELVERZEICHNIS - INDICE DE TABLAS	PAGE NO.
DRAWBAR CONTROL BOX / TIMONE SCATOLA COMANDI / BARRE BOITE DE COMMANDE / DEICHSEL STEUERUNGSBUCHSE (SHEET 12.A)	24-25
HYDRAULIC SYSTEM / IMPIANTO IDRAULICO / INSTALLATION HYDRAULIQUE / HYDRAULIKANLAGE / INSTALLACION HIDRAULICA (SHEET 13.A)	26
HYDRAULIC CYLINDER / CILINDRO IDRAULICO / CYLINDRE HYDRAULIQUE / HYDRAULIK ZYLINDER / CILINDRO IDRAULICO (SHEET 14.A).....	27
DISTRIBUTOR / CENTRALINA IDRAULICA / DISTRIBUTEUR / STEUERUNG / DISTRIBUIDOR (SHEET 15.A)	28-29
ELECTRIC HORN / CLACKSON MAGGIORATO / KLAXON MAJORE / VERSTAERKTE HUPE / AVISADOR ACUSTICO AUMENTADO(SHEET 16.A).....	30
BATTERY CHARGER / CARICA BATTERIA / CHARGUER / AULFLADERÄT / CARGADOR DE BATERIAS (SHEET 17.A).....	31
ELECTRICAL DIAGRAM / SCHEMA ELETTRICO / SCHEMA ELECTRIQUE / SCHALTPLAN / ESQUEMA ELECTRICO (SHEET 18.A).....	32
SHEATH DIAGRAM / SCHEMA COLLEGAMENTI GUAINA / DIAGRAMME LIAISON GAINES / MONTELANLAGEPLAN / ESQUEMA CONEXION VAINA (SHEET 19.A/19.B).....	33-34
WIRING DIAGRAM / SCHEMA COLLEGAMENTI CAVI POTENZA / DIAGRAMMA LIAISON CABLE ELECTRIQUE / ELEKTRTSCHENANLAGEPLAN / ESQUEMA CONEXION CABLE POTENCIA(SHEET 20.A)	35
CONSOLE ADAPTER / ADATTATORE PER CONSOLE / ADAPTATEUR POUR CONSOLE / ADAPTER FÜR KONSOLLE / ADAPTADOR POR CONSOLA (SHEET 21.A)	36
HYDRAULIC DIAGRAM / SCHEMA IDRAULICO / SCHEMA HYDRAULIQUE / HYDRAULIKPLAN / ESQUEMA HIDRAULICO (SHEET 22.A).....	37
CONNECTORS, CONTACTS, TOOLS / CONTATTI, CONNETTORI, UTENSILI / CONNECTEURS, CONTACTS, OUTILS / KONNEKTORS, KONTAKTS, WERKZEUG / CONTACTO, CONECTOR, UTENSILIO(SHEET 23.A)	38-39
NUMERICAL INDEX / INDICE NUMERICO / INDEX GENERAL / ALGEMEINER INDEX / INDICE GENERAL.....	40-41

<https://www.ebooklibonline.com>

Hello dear friend!

Thank you very much for reading.

Enter the link into your browser.

The full manual is available for immediate download.

<https://www.ebooklibonline.com>

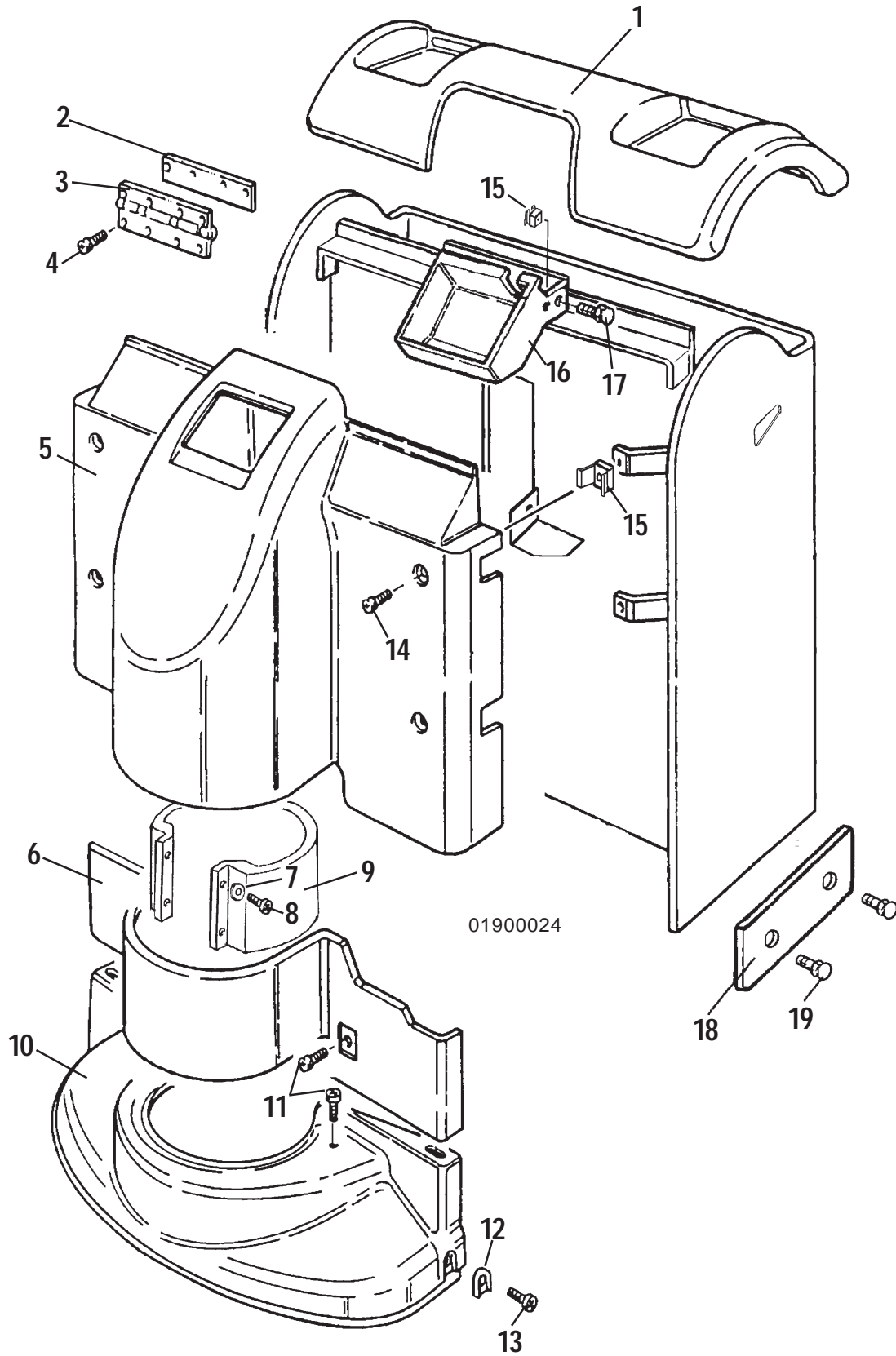

Da matr. / Du matr. / Ab. seriennummer
From serial N° / Desde la matr.:

Fino a matr. / Jusqu' matr. / Bis zur serien-Nr.
Until serial N° / Hasta la matr.:

Ad esclusione di / A l'exclusion de
Mit ausnahme von / With the exception of / Excepto:

Compreso / Avec / Einschließlich
Including / Con:

C856X01525A



SHEET 1.A

COVERS
CARTER
COUVERCLE
DECKEL
TAPAS

Truck Model
Carrello Tipo
Chariot Modele
Staplertyp
Tipo de carretilla

MP25HD
MP30HD

REF	PART N°	Qt.	DESCRIPTION	DESCRIZIONE	DESIGNATION	BENENNUNG	DENOMINACIONES
1	272104200	1	Battery cover	Coperchio batteria	Couvercle batterie	Batterie deckel	Cubierta bateria
2	272338200	2	Plate	Piastra	Plaque	Platte	Placa
3	272337900	2	Hinge	Cerniera	Charniere	Scharnier	Charnela
4	272383500	6	Screw	Vite	Vis	Schraube	Tornillo
5	272368300	1	Cover	Coperchio	Couvercle	Deckel	Tapa
6	272151000	1	Cover	Coperchio	Couvercle	Deckel	Tapa
7	449021003	4	Washer	Rondella	Rondelle	Scheibe	Arandela
8	272328700	4	Screw	Vite	Vis	Schraube	Tornillo
9	272172200	1	Collar	Collare	Collier	Schelle	Collar
10	272129900	1	Cover	Carter inferiore	Couvercle	Deckel	Tapa
11	272033100	10	Screw	Vite	Vis	Schraube	Tornillo
12	272099100	2	Vibrat damping	Antivibrante	Antivibrant	Schw ingungsdamp	Antivibrador
13	272105600	2	Screw	Vite	Vis	Schraube	Tornillo
14	272033100	8	Screw	Vite	Vis	Schraube	Tornillo
15	272342200	8	Nut	Dado in gabbia	Ecrou	Mutter	Tuerca
16	580024261	1	Support	Supporto	Support	Lager	Soporte
17	272330000	1	Screw	Vite	Vis	Schraube	Tornillo
18	580041288	2	Guard	Protezione	Protection	Shutz	Defensa
19	580006788	4	Screw	Vite	Vis	Schraube	Tornillo

Da matr. / Du matr. / Ab. seriennummer
From serial N° / Desde la matr.:

Fino a matr. / Jusqu' matr. / Bis zur serien-Nr.
Until serial N° / Hasta la matr.:

Ad esclusione di / À l'exclusion de
Mit ausnahme von / With the exception of / Excepto:

Compreso / Avec / Einschließlich
Including / Con:

C856X01525A

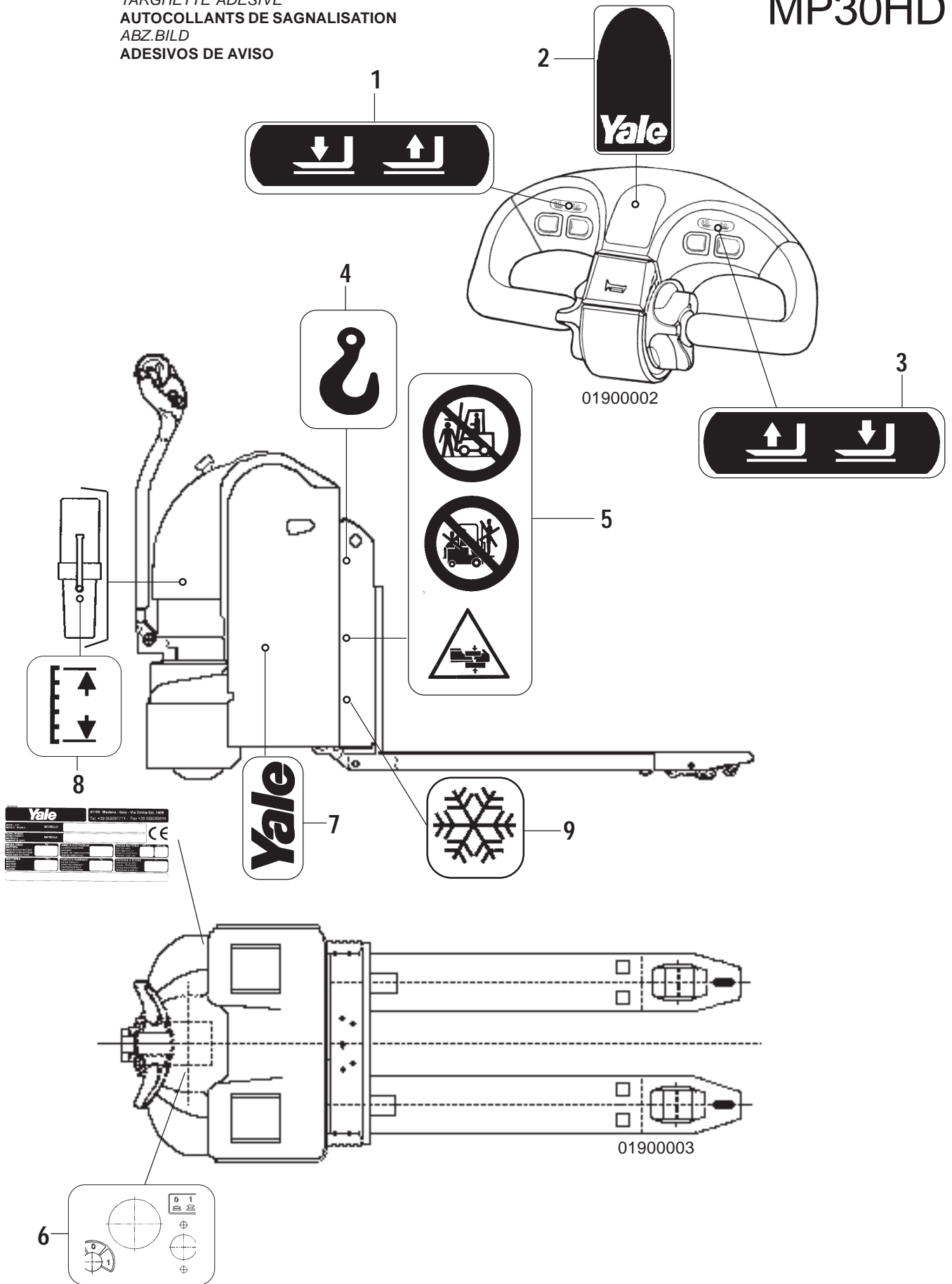

Da matr. / Du matr. / Ab. seriennummer
 From serial N° / Desde la matr.:

Fino a matr. / Jusqu' matr. / Bis zur serien-Nr.
 Until serial N° / Hasta la matr.:

Ad esclusione di / A l'exclusion de
 Mit ausnahme von / With the exception of / Excepto:

Compreso / Avec / Einschließlich
 Including / Con:

C856X01525A



Suggest:

For more complete manuals. Please go to the home page.

<https://www.ebooklibonline.com>

If the above button click is invalid. Please download this document first, and then click the above link to download the complete manual.

Thank you so much for reading



SHEET 2.A

ADESIVE LABELS
TARGHETTE ADESIVE
AUTOCOLLANTS DE SAGNALISATION
ABZ.BILD
ADESIVOS DE AVISO

Truck Model
 Carrello Tipo
 Chariot Modele
 Staplertyp
 Tipo de carretilla

MP25HD
MP30HD

REF	PART N°	Qt.	DESCRIPTION	DESCRIZIONE	DESIGNATION	BENENNUNG	DENOMINACIONES
1	580012968	1	Adhesive label	Adesivo	Autocollants	Abz-bild	Adesivos
2	524139322	1	Adhesive label	Adesivo	Autocollants	Abz-bild	Adesivos
3	580012967	1	Adhesive label	Adesivo	Autocollants	Abz-bild	Adesivos
4	272213500	1	Adhesive label	Adesivo	Autocollants	Abz-bild	Adesivos
5	272303000	2	Adhesive label	Adesivo	Autocollants	Abz-bild	Adesivos
6	580024244	1	Adhesive label	Adesivo	Autocollants	Abz-bild	Adesivos
7	272219100	2	Adhesive label	Adesivo	Autocollants	Abz-bild	Adesivos
8	272213600	1	Adhesive label	Adesivo	Autocollants	Abz-bild	Adesivos
9	580014880	1	Adhesive label -30°	Adesivo -30°	Autocollants -30°	Abz-bild -30°	Adesivos -30°

Da matr. / Du matr. / Ab. seriennummer
 From serial N° / Desde la matr.:

Fino a matr. / Jusqu' matr. / Bis zur serien-Nr.
 Until serial N° / Hasta la matr.:

Ad esclusione di / À l'exclusion de
 Mit ausnahme von / With the exception of / Excepto:

Compreso / Avec / Einschließlich
 Including / Con:

C856X01525A

FRAME BATTERY VERTICAL REMOVAL
TELAIO BATTERIA ESTRAZIONE VERTICALE
CHASSIS BATTERIE VERTICAL EXTRACTION
BATTERIEWECHSEL KONVETIONELLE BATTERIE ENDNHAME
BASTIDOR BATERIA EXTRACCION VERTICAL

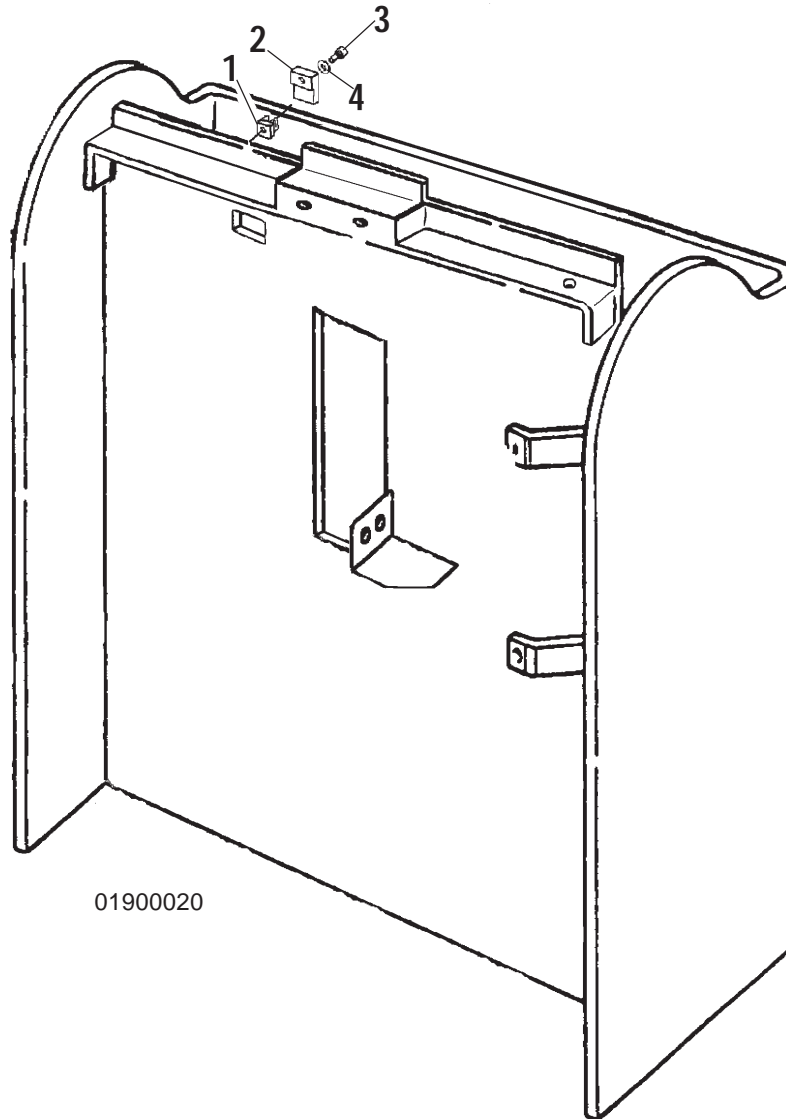

01900020

REF	PART N°	Qt.	DESCRIPTION	DESCRIZIONE	DESIGNATION	BENENNUNG	DENOMINACIONES
1	580015667	2	Nut	Dado in gabbia	Ecrou	Mutter	Tuerca
2	272369100	2	Battery stop	Fermo batteria	Fix ation batterie	Batteriestillstand	Sujetador bateria
3	580015669	2	Screw	Vite	Vis	Schrauben	Tornillo
4	272211100	2	Washer	Rondella	Rondelle	Scheibe	Arandela

Da matr. / Du matr. / Ab. seriennummer
From serial N° / Desde la matr.:

Fino a matr. / Jusqu' matr. / Bis zur serien-Nr.
Until serial N° / Hasta la matr.:

Ad esclusione di / A l'exclusion de
Mit ausnahme von / With the exception of / Excepto:
Including / Con:

Compreso / Avec / Einschließlich

C856X01525A

<https://www.ebooklibonline.com>

Hello dear friend!

Thank you very much for reading.

Enter the link into your browser.

The full manual is available for immediate download.

<https://www.ebooklibonline.com>