

**MS14 MS16
MS14 MS16
(C852)**

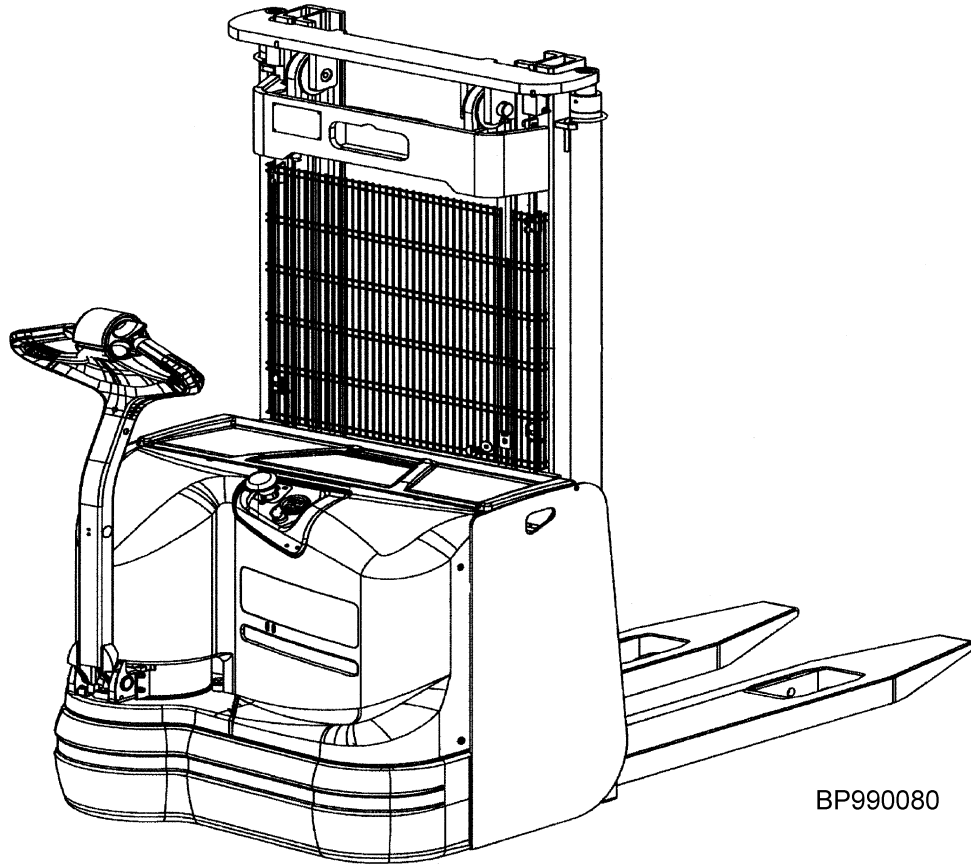

BP990080

SECTIONS

1	FRAME/DRIVE UNIT
2	ELECTRICAL SYSTEM
3	LOAD WHEEL
4	HYDRAULIC SYSTEM
5	MAST-TWO STAGE FULL FREE-LIFT
6	MAST-THREE STAGE FULL FREE-LIFT
7	OPTIONS
8	NUMERICAL INDEX

<https://www.ebooklibonline.com>

Hello dear friend!

Thank you very much for reading.

Enter the link into your browser.

The full manual is available for immediate download.

<https://www.ebooklibonline.com>

TABLE OF CONTENTS

DESCRIPTION	PAGE
B	
BATTERY COMPARTMENT	
LATERAL BATTERY REMOVAL	1-6
BATTERY ROLLER TRUCK	7-2
C	
COVERS AND ADHESIVE LABELS	1-2
D	
DISTRIBUTOR	4-2
DRAWBAR CONTROL BOX	
PROPORTIONAL SWITCH VERSION	1-18
E	
ELECTROMAGNETIC BRAKE	1-16
ELECTRONIC SYSTEM	2-2
F	
FORK 2 STAGE	
FFL	5-8
HI VI	5-10
FORK 3 STAGE	
FFL	6-6
H	
HYDRAULIC CYLINDER	
2 STAGE FFL	4-7
2 STAGE HI-VI	4-6
3 STAGE	4-8
HYDRAULIC SYSTEM	4-4
L	
LEXAN GUARD	
2 STAGE FFL	7-6
2 STAGE HI-VI	7-4
3 STAGE FFL	7-8
LOAD WHEELS	3-2
M	
MAST 2 STAGE	
FFL	5-2
HI VI	5-6
MAST 3 STAGE	
FFL	6-2
P	
POWER CABLES DIAGRAM	2-4
S	
SUPPORTS AND CASTER WHEELS	1-10

TABLE OF CONTENTS (continued)

DESCRIPTION	PAGE
T	
TRACTION MOTOR	1-14
TRACTION UNIT	1-12
W	
WIRE HARNESS DIAGRAM	2-6
WIRE NET	5-12

ABBREVIATIONS QUICK REFERENCE SHEET

Listed below are abbreviations used in parts manuals to denote the following expressions:

TERM	DEFINITION	TERM	DEFINITION
Amp	Amperes	FRE	Freezer Environment
AR	As Required	in.	inches
BDI	Battery Discharge Indicators	LPG	Liquefied Petroleum Gas
BWI	Brush Wear Indicator	MAP	Manifold Absolute Pressure
CE	Communicator End	mm	millimeters
CRE	Corrosive Environment	MSTS	Microprocessor Spark Timing System
D/B	Date Break	NPT	National Pipe Threads
dbA	Decibel "A" Scale	O/S	Oversize
DE	Drive End	PTO	Power Take Off
ECH	Empty Container Handler	RPM	Revolutions per Minute
ECH-3	Empty Container Handler - 3 High Stacking	S/N	Serial Number
ECH-4	Empty Container Handler - 4 High Stacking	TMM	Truck Management Module
ECH-5	Empty Container Handler - 5 High Stacking	UL Type D	Diesel-Powered Safety Rating
ECH-6	Empty Container Handler - 6 High Stacking	UL Type DS	Diesel-Powered Safety Rating
ECH-7	Empty Container Handler - 7 High Stacking	UL Type E	Battery-Powered Safety Rating
ECM	Electronic Control Module	UL Type EE	Battery-Powered Safety Rating
ECN	Engineering Change Notice	UL Type ES	Battery-Powered Safety Rating
EEPROM	Electrically Erasable Programmable Read Only Memory	UL Type G	Gasoline-Powered Safety Rating
EPA	US Environmental Protection Agency	UL Type GS	Gasoline-Powered Safety Rating
EPROM	Electrically Programmable Read Only Memory	UL Type LP	Gas-Powered Safety Rating
		UL Type LPS	LP Gas-Powered Safety Rating
		U/S	Undersize
		UL	Underwriters Laboratory
		V	Volts

1

FRAME/DRIVE UNIT

SECTION 1
FRAME/DRIVE UNIT

DESCRIPTION	PAGE
BATTERY COMPARTMENT	
LATERAL BATTERY REMOVAL	1-6
COVERS AND ADHESIVE LABELS	1-2
DRAWBAR CONTROL BOX	
PROPORTIONAL SWITCH VERSION	1-18
ELECTROMAGNETIC BRAKE	1-16
SUPPORTS AND CASTER WHEELS	1-10
TRACTION MOTOR	1-14
TRACTION UNIT	1-12

COVERS AND ADHESIVE LABELS (FIGURE 1-1)

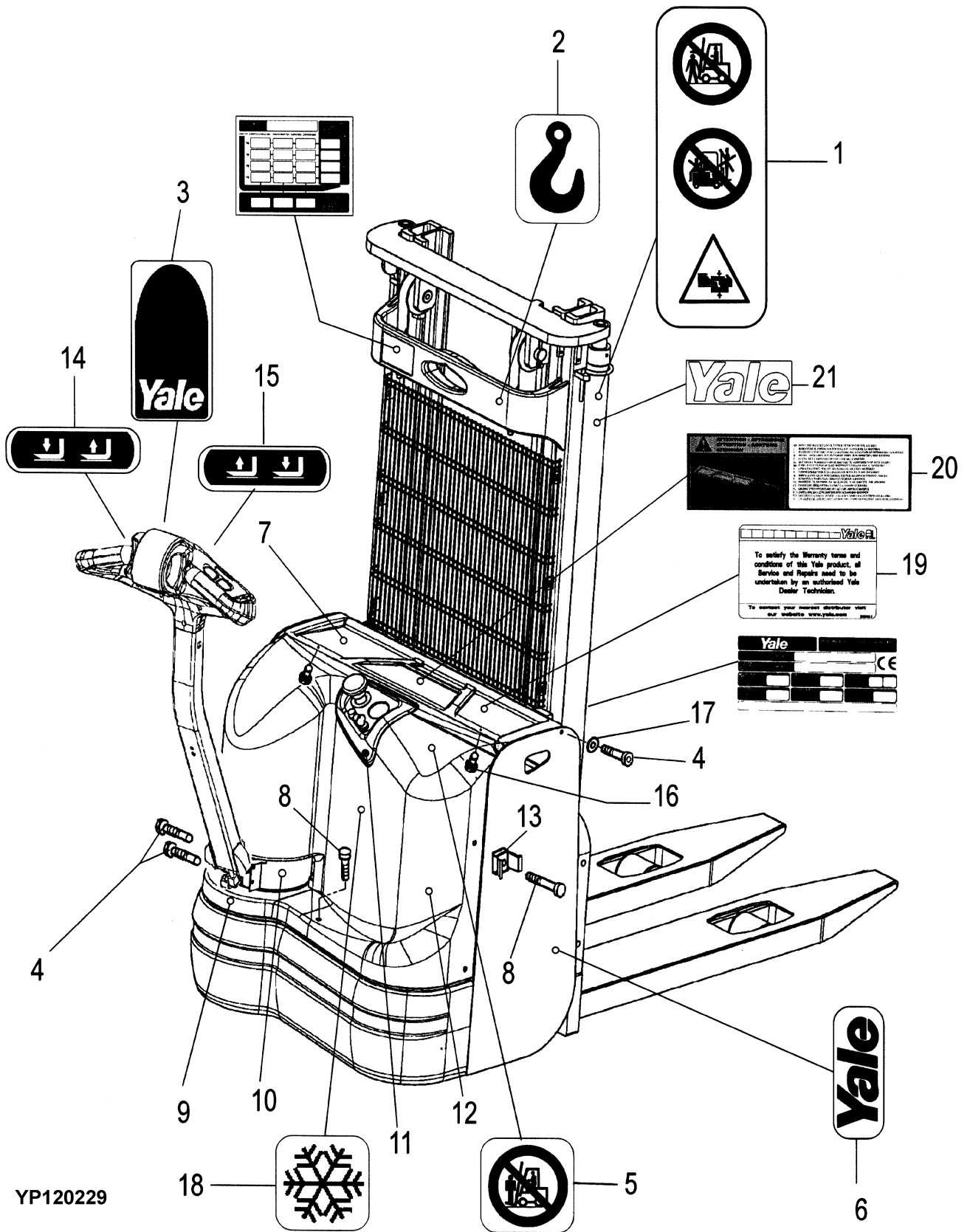

YP120229

COVERS AND ADHESIVE LABELS

ITEM	PART NO.	DESCRIPTION	QTY
1	272303000	Label	2
2	272213500	Label (Lifting Hook)	1
3	524139322	Label (Yale)	1
4	272328700	Screw	6
5	272213200	Label	1
6	150802070	Label (Hyster)	2
7	580013324	Cover	1
7	580013325	Cover	1
8	449007018	Screw	4
9	524141524	Cover	1
10	580013326	Cover	1
11	524327019	Cover	1
12	524141523	Cover	1
13	580093734	Clip	4
14	580012968	Label (LH Switch Functions)	1
15	580012967	Label (RH Switch Functions)	1
16	277458400	Cushion	2
17	580012959	Spacer	2
18	580014880	Label (Snowflake)	1
19	524216189	Label (Warranty) English	1
19	524216191	Label Brazilian	1
19	524216192	Label Czech	1
19	524216193	Label Danish	1
19	524216194	Label Dutch	1
19	524216195	Label Estonian	1
19	524216196	Label Finnish	1
19	524216197	Label (Warranty) French	1
19	524216198	Label (Warranty) German	1
19	524216199	Label Greek	1
19	524216200	Label Hungarian	1
19	524216201	Label Icelandic	1
19	524216202	Label (Warranty) Italian	1
19	524216203	Label Latvian	1
19	524216204	Label Lithuanian	1
19	524216205	Label Norwegian	1
19	524216206	Label Polish	1
19	524216207	Label Portuguese	1
19	524216208	Label Romanian	1
19	524216209	Label Russian	1
19	524216210	Label Slovakian	1
19	524216190	Label Slovenian	1
19	524216211	Label (Warranty) Spanish	1
19	524216212	Label Swedish	1
19	524216526	Label Turkish	1
19	524216766	Label Croatian	1
20	580053923	Instruction Label	1
21	524242350	Label	2

BATTERY COMPARTMENT (FIGURE 1-2)
LATERAL BATTERY REMOVAL

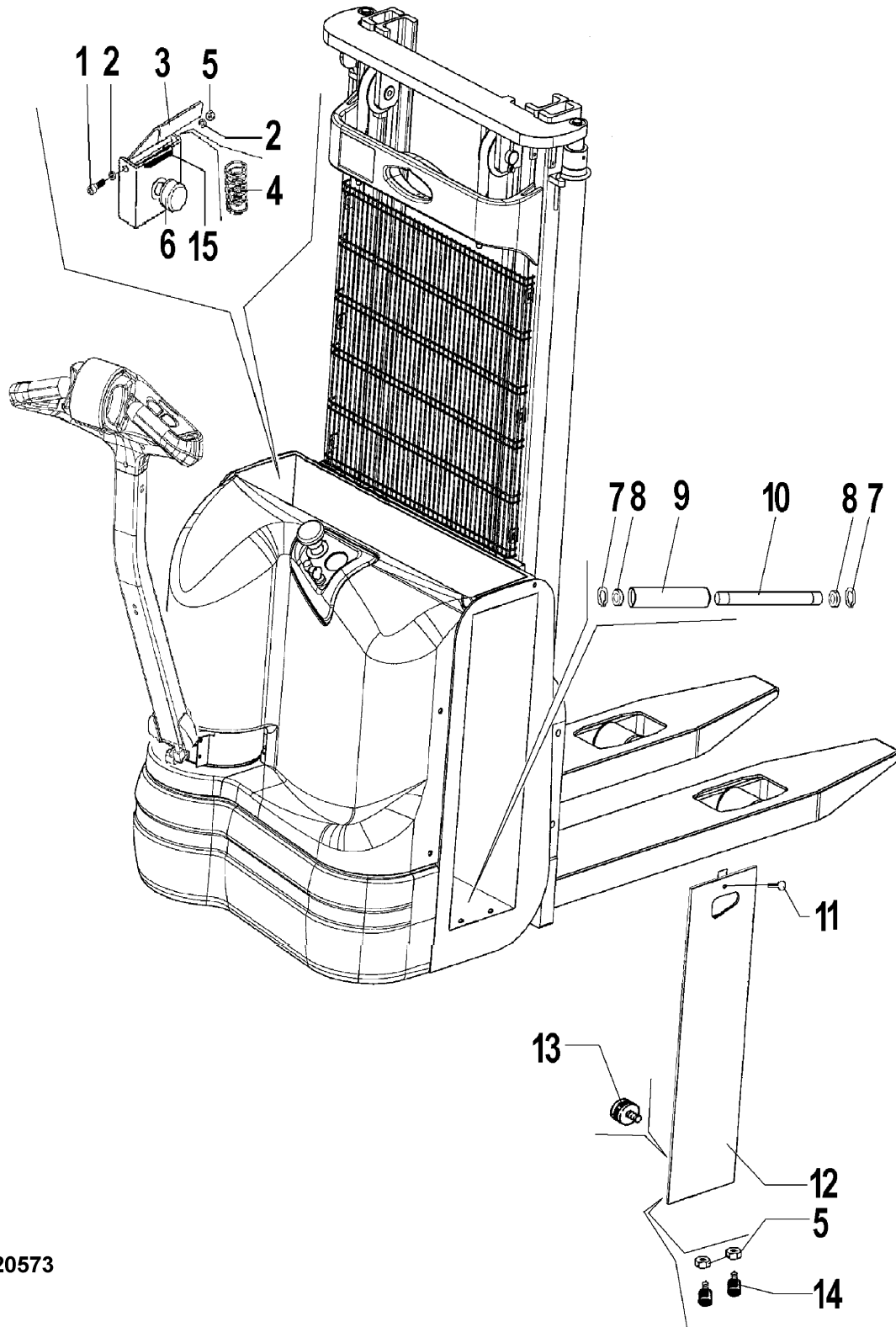

BP120573

**BATTERY COMPARTMENT
LATERAL BATTERY REMOVAL**

ITEM	PART NO.	DESCRIPTION	QTY
1	272458700	Capscrew	1
2	449021001	Washer	2
3	524139713	Frame	3
4	580014526	Extension Spring	1
5	449015098	Nut	3
6	272470200	Bumper	1
7	015918400	Snap Ring	6
8	272387700	Bearing	6
9	272387100	Tube Assy	3
10	272409600	Rod	3
11	272471100	Key	1
12	580014631	Frame	1
13	272470200	Bumper	1
14	580013298	Shock Absorber	2
15	580029307	Trim-Bulk (M)	1



Suggest:

For more complete manuals. Please go to the home page.

<https://www.ebooklibonline.com>

If the above button click is invalid. Please download this document first, and then click the above link to download the complete manual.

Thank you so much for reading

SUPPORTS AND CASTER WHEELS (FIGURE 1-3)

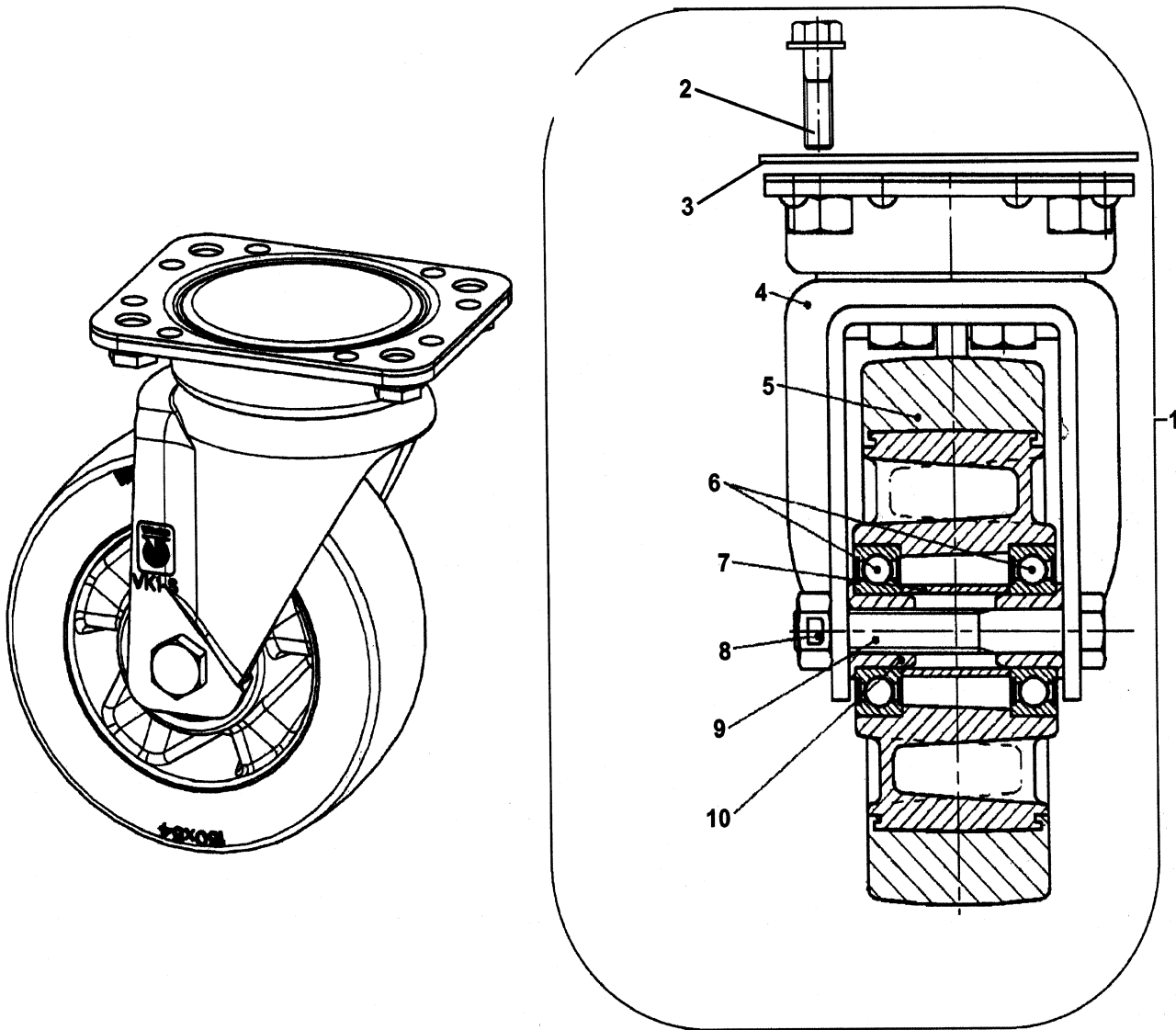

BP120569

SUPPORTS AND CASTER WHEELS

ITEM	PART NO.	DESCRIPTION	QTY
1	580092328	Caster Wheel	1
2	580013314	Screw	2
3	580013312	Spacer	1
4	580092729	Swivel Fork	1
5	580092728	Wheel	1
6	015120100	Ball Bearing	2
7	580092727	Axle Shaft	1
8	524148554	Locknut	1
9	931015914	Capscrew	1
10	580037730	Bushing	2

<https://www.ebooklibonline.com>

Hello dear friend!

Thank you very much for reading.

Enter the link into your browser.

The full manual is available for immediate download.

<https://www.ebooklibonline.com>