

GDP/GLP35-55LJ/MJ (C813)

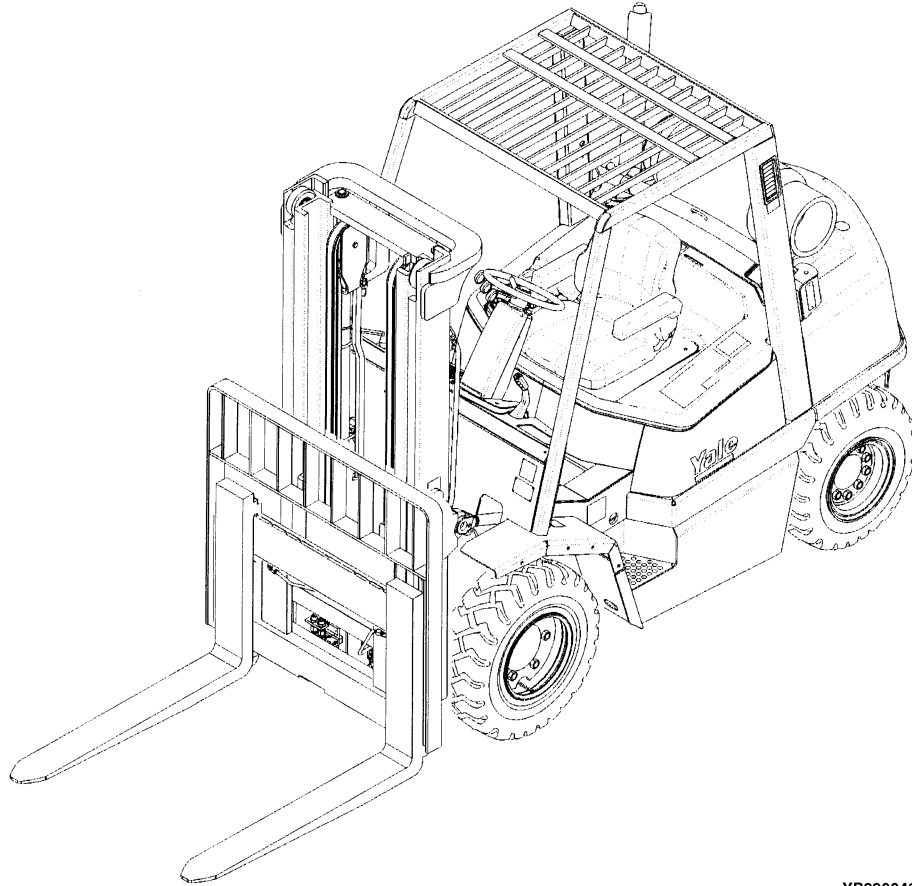

YP990043

1	GENERAL TRUCK
2	DIESEL ENGINE (1004.42)
3	LPG ENGINE (4.3L)
4	FUEL SYSTEM
5	ELECTRICAL SYSTEM
6	STEERING SYSTEM
7	BRAKE SYSTEM
8	TRANSMISSION
9	HYDRAULIC SYSTEM
10	MAST-TWO STAGE LIMITED FREE-LIFT
11	MAST-THREE STAGE FULL FREE-LIFT
12	MAST-TWO STAGE FULL FREE-LIFT
13	OPTIONS
14	NUMERICAL INDEX

ALPHABETICAL INDEX

DESCRIPTION	PAGE NO.
A	
ABBREVIATIONS QUICK REFERENCE SHEET	x
AIR FILTER.....	4.52
AIR SYSTEM.....	4.50
ALPHABETICAL INDEX.....	i
ALTERNATOR	
MOUNT	
GDP 35 LJ, GDP 40 LJ, GDP 45 MJ, GDP 50 MJ, GDP 55 MJ	
D/B 07/2001⇒	2.14
⇒D/B 07/2001	2.12
⇒S/N C813A-02227Y	5.30
AUDIBLE ALARM.....	13.80
AUXILIARY TUBE EXTENSION KIT	
THREE STAGE FULL FREE-LIFT	13.24
TWO STAGE LIMITED FREE-LIFT.....	13.22
B	
BAFFLE AND ATTACHING PARTS	
GDP35LJ, GDP40LJ, GDP45MJ, GDP50MJ, GDP55MJ	2.6
GLP35LJ, GLP40LJ, GLP45MJ, GLP50MJ, GLP55MJ	3.16
BRAKE ASSEMBLY	
GLP/GDP35LJ, GLP/GDP40LJ	7.8
GLP/GDP45MJ, GLP/GDP50MJ, GLP/GDP55MJ.....	7.12
BRAKE RELAY ASSEMBLY	7.18
BRAKE SYSTEM	
HYDROSTATIC TRANSMISSION.....	7.6
POWERSHIFT TRANSMISSION.....	7.2
C	
CAB	
ATTACHING PARTS.....	13.60
DOOR ASSEMBLY	13.70
ELECTRICAL.....	13.64
FRAME	13.58
WINDOWS AND WIPER MOTOR	13.68
CAMSHAFT AND OIL SUMP	
GLP35LJ, GLP40LJ, GLP45MJ, GLP50MJ, GLP55MJ	3.36
CARBURETOR	
LPG	
WITH LOW EMISSIONS	4.40
CARRIAGE	
THREE STAGE FULL FREE-LIFT	11.30
TWO STAGE FULL FREE-LIFT	12.18
TWO STAGE LIMITED FREE-LIFT.....	10.16
CONTROL VALVE	
TRANSMISSION.....	8.18
COOLANT PUMP	

<https://www.ebooklibonline.com>

Hello dear friend!

Thank you very much for reading.

Enter the link into your browser.

The full manual is available for immediate download.

<https://www.ebooklibonline.com>

DESCRIPTION	PAGE NO.
C (continued)	
GDP35LJ, GDP40LJ, GDP45MJ, GDP50MJ, GDP55MJ	
D/B 09/2001⇒.....	2.36
⇒D/B 09/2001.....	2.34
COOLING	
GDP35LJ, GDP40LJ, GDP45MJ, GDP50MJ, GDP55MJ	2.42
GLP35LJ, GLP40LJ, GLP45MJ, GLP50MJ, GLP55MJ	3.14
COUNTERWEIGHT	1.12
CRANKSHAFT AND PISTON	
GDP35LJ, GDP40LJ, GDP45MJ, GDP50MJ, GDP55MJ	
D/B 07/2001⇒.....	2.22
⇒D/B 07/2001.....	2.20
CYLINDER BLOCK	
GDP35LJ, GDP40LJ, GDP45MJ, GDP50MJ, GDP55MJ	
D/B 07/2001⇒.....	2.18
⇒D/B 07/2001.....	2.16
GLP35LJ, GLP40LJ, GLP45MJ, GLP50MJ, GLP55MJ	3.28
CYLINDER HEAD	
GDP35LJ, GDP40LJ, GDP45MJ, GDP50MJ, GDP55MJ	2.32
GLP35LJ, GLP40LJ, GLP45MJ, GLP50MJ, GLP55MJ	3.32
D	
DIFFERENTIAL ASSEMBLY	8.24
DIRECTIONAL CONTROL PEDAL	4.70
DIRECTIONAL CONTROL PEDAL LINKAGE.....	4.68
DISTRIBUTOR	
GLP35LJ, GLP40LJ, GLP45MJ, GLP50MJ, GLP55MJ	5.32
DRIVE AXLE	8.26
HYDROSTATIC TRANSMISSION.....	8.30
E	
ELECTRICAL SYSTEM	
ALTERNATOR AND BATTERY	
GLP35LJ, GLP40LJ, GLP45MJ, GLP50MJ, GLP55MJ.....	5.26
COWL	
HYDROSTATIC TRANSMISSION	5.8
POWERSHIFT TRANSMISSION	5.4
GDP35LJ, GDP40LJ, GDP45MJ, GDP50MJ, GDP55MJ	
⇒S/N C813A-01696.....	5.14
S/N C813A-01697⇒.....	5.18
GLP35LJ, GLP40LJ, GLP45MJ, GLP50MJ, GLP55MJ	5.22
THROTTLE UP	
HYDROSTATIC TRANSMISSION	5.12
ENGINE AND ATTACHING PARTS	
GDP35LJ, GDP40LJ, GDP45MJ, GDP50MJ, GDP55MJ	2.10
GLP35LJ, GLP40LJ, GLP45MJ, GLP50MJ, GLP55MJ	3.22
ENGINE MOUNT	
GDP35LJ, GDP40LJ, GDP45MJ, GDP50MJ, GDP55MJ	2.8
POWERSHIFT TRANSMISSION	

DESCRIPTION	PAGE NO.
E (continued)	
GLP35LJ, GLP40LJ, GLP45MJ, GLP50MJ, GLP55MJ.....	3.26
EXHAUST	
GDP35LJ, GDP40LJ, GDP45MJ, GDP50MJ, GDP55MJ	2.44
GLP35LJ, GLP40LJ, GLP45MJ, GLP50MJ, GLP55MJ WITHOUT LOW EMISSIONS	
⇒S/N C813A02831A.....	3.6
S/N C813A02832A⇒.....	3.8
THREE-WAY CATALYTIC CONVERTER WITH LOW EMISSIONS	
GLP35LJ, GLP40LJ, GLP45MJ, GLP50MJ, GLP55MJ	
⇒S/N C813A02831A.....	3.10
S/N C813A02832A⇒.....	3.12
EXHAUST MANIFOLD	
GLP35LJ, GLP40LJ, GLP45MJ, GLP50MJ, GLP55MJ	
⇒S/N C813A02831A	3.2
S/N C813A02832A⇒	3.4
F	
FAN	
DRIVE ASSEMBLY	
GDP35LJ, GDP40LJ, GDP45MJ, GDP50MJ, GDP55MJ.....	2.2
GLP35LJ, GLP40LJ, GLP45MJ, GLP50MJ, GLP55MJ.....	3.18
FENDER	
EXTENSION	
GLP/GDP35LJ, GLP/GDP40LJ.....	13.18
GLP/GDP45MJ, GLP/GDP50MJ, GLP/GDP55 MJ	13.20
FILTER AND LOCK-OFF VALVE	
GLP35LJ, GLP40LJ, GLP45MJ, GLP50MJ, GLP55MJ	
⇒S/N C813A01935Y	4.46
FILTER ASSEMBLY	
HYDROSTATIC TRANSMISSION.....	8.42
FLOOR PLATES AND COVERS	1.6
FORK	
HOOK TYPE	
THREE STAGE FULL FREE-LIFT	11.36
TWO STAGE FULL FREE-LIFT	12.21
TWO STAGE LIMITED FREE-LIFT	10.20
FREE-LIFT	
THREE STAGE FULL FREE-LIFT	11.18
FREE-LIFT CYLINDER	
THREE STAGE FULL FREE-LIFT	11.26
TWO STAGE FULL FREE-LIFT	12.14
FUEL FILTER	
LOW PRESSURE SYSTEM	4.12
FUEL INJECTION	
GDP35LJ, GDP40LJ, GDP45MJ, GDP50MJ, GDP55MJ	4.14
FUEL SYSTEM	
CLOSED LOOP	
GLP 070 LJ - GLP 120 MJ	

DESCRIPTION	PAGE NO.
F (continued)	
D/B 12/2003⇒	4.36
GLP35LJ, GLP40LJ, GLP45MJ, GLP50MJ, GLP55MJ	
⇒D/B 12/2003	4.32
GDP35LJ, GDP40LJ, GDP45MJ, GDP50MJ, GDP55MJ	4.4
OPEN LOOP	
GLP35LJ, GLP40LJ, GLP45MJ, GLP50MJ, GLP55MJ	
D/B 12/2003⇒	4.28
⇒S/N C813A-01935Y	4.20
S/N C813A-01936Y⇔D/B 12/2003	4.24
FULL SUSPENSION SEAT	
SHEET 1 OF 2	1.22
SHEET 2 OF 2	1.24
G	
GOVERNOR	
GLP35LJ, GLP40LJ, GLP45MJ, GLP50MJ, GLP55MJ	4.49
H	
HEADER HOSE	
THREE STAGE FULL FREE-LIFT	11.38
TWO STAGE FULL FREE-LIFT	12.22
TWO STAGE LIMITED FREE-LIFT	
⇒S/N A749A-02522Z, ⇒S/N A750A-02672Z	10.22
S/N A749A-02523Z⇒, S/N A750A-02673Z⇒	10.26
HEADLIGHTS, REAR LIGHTS, AND SIDE LAMPS	
WITHOUT CAB	
⇒S/N C813A02993A	13.26
HEADLIGHTS, REAR LIGHTS, AND SIDE LIGHTS	
WITHOUT CAB	
S/N C813E02994A⇒	13.28
HEATER	13.74
HEATER INSTALLATION	
GDP35LJ, GDP40LJ, GDP45MJ, GDP50MJ, GDP55MJ	13.78
GLP35LJ, GLP40LJ, GLP45MJ, GLP50MJ, GLP55MJ	13.76
HOOD AND COVERS	1.2
HOW TO FIND THE DESIRED PART NUMBER	xii
HOW TO USE THE ILLUSTRATED PARTS MANUAL	xii
HYDRAULIC CONTROL LINES	
FOUR FUNCTION	9.12
THREE FUNCTION	9.10
HYDRAULIC CONTROL VALVE	
SHEET 1 OF 2	
THREE AND FOUR FUNCTION	
S/N C813A2192Y⇒	9.22
SHEET 2 OF 2	
THREE AND FOUR FUNCTION	
S/N C813A2192Y⇒	9.26
THREE AND FOUR FUNCTION	

DESCRIPTION	PAGE NO.
H (continued)	
⇒S/N C813A-2191Y	9.20
HYDRAULIC CONTROL VALVE ATTACHING PARTS	
FOUR FUNCTION	9.16
THREE FUNCTION	9.14
WITH HYDROSTATIC TRANSMISSION	9.18
HYDRAULIC FILTER HOUSING	9.28
HYDRAULIC PUMP	9.34
HYDRAULIC PUMP AND MOUNT	
HYDROSTATIC TRANSMISSION	8.36
HYDRAULIC SYSTEM	
WITH HYDROSTATIC TRANSMISSION	9.6
WITH POWERSHIFT TRANSMISSION	9.2
I	
IDENTIFICATION OF ATTACHMENT AND SIDE-SHIFT CARRIAGE SERIAL NUMBERS	xv
IDENTIFICATION OF MAST SERIAL NUMBER	xiv
IDENTIFICATION OF TRUCK SERIAL NUMBER	xiii
INNER AND FREE LIFT MAST	
TWO STAGE FULL FREE-LIFT	12.6
INNER MAST	
THREE STAGE FULL FREE-LIFT	11.10
TWO STAGE LIMITED FREE-LIFT	10.4
INPUT AND DIRECTIONAL CLUTCH	8.16
INSTRUMENT PANEL	5.11
INTERMEDIATE MAST	
THREE STAGE FULL FREE-LIFT	11.6
L	
LABELS	1.29
LIFT CYLINDER	
TWO STAGE FULL FREE-LIFT	12.10
LIFT PUMP	
GDP35LJ, GDP40LJ, GDP45MJ, GDP50MJ, GDP55MJ	4.18
LOAD BACKREST	
TWO STAGE FULL FREE-LIFT	12.26
LOAD BACKREST EXTENSION	
THREE STAGE FULL FREE-LIFT	11.34
TWO STAGE LIMITED FREE-LIFT	10.18
LOW PRESSURE SYSTEM	
GDP35LJ, GDP40LJ, GDP45MJ, GDP50MJ, GDP55MJ	
⇒D/B 07/2001	4.8
GDP35LJ, GDP40LJ, GDP45MJ, GDP50MJ, GDP55MJ)	
D/B 07/2001⇒	4.10
LPG CONVERTER	
OPEN LOOP	
⇒S/N C813A-01935Y	4.47
S/N C813A-01936Y⇔D/B 10/2003	4.48
LPG TANK BRACKET	

DESCRIPTION	PAGE NO.
L (continued)	
FIXED	4.42
SWING OUT	4.44
M	
MAIN CYLINDER	
THREE STAGE FULL FREE-LIFT	11.22
TWO STAGE LIMITED FREE-LIFT	10.12
MAIN LIFT	
THREE STAGE FULL FREE-LIFT	11.14
TWO STAGE LIMITED FREE-LIFT	10.8
MANIFOLD VALVE	8.20
MANIFOLDS	
GDP35LJ, GDP40LJ, GDP45MJ, GDP50MJ, GDP55MJ	
D/B 07/2001⇒	2.30
⇒D/B 07/2001	2.28
MAST INSTALLATION	9.30
MASTER CYLINDER AND BRAKE BOOSTER	7.14
MIRROR	
DUAL WITHOUT CAB	13.36
N	
NON-SUSPENSION SEAT	1.18
O	
OIL FILTER	
GDP35LJ, GDP40LJ, GDP45MJ, GDP50MJ, GDP55MJ	2.27
OIL PUMP	
GLP35LJ, GLP40LJ, GLP45MJ, GLP50MJ, GLP55MJ	3.40
OIL SUMP AND PUMP	
GDP35LJ, GDP40LJ, GDP45MJ, GDP50MJ, GDP55MJ	2.24
OPERATOR MODULE	1.16
OUTER MAST	
THREE STAGE FULL FREE-LIFT	11.2
TWO STAGE LIMITED FREE-LIFT	10.2
OUTER MAST AND MAIN LIFT	
TWO STAGE FULL FREE-LIFT	12.2
OVERHEAD GUARD	1.14
P	
PARK BRAKE	7.16
POWERTRAIN MOUNT	8.4
R	
REAR DRIVE LIGHTS	
SINGLE	
WITHOUT CAB	13.30
REAR SCREEN	

DESCRIPTION	PAGE NO.
R (continued)	
⇒S/N C813A-01588	1.20
S/N C813A-01589⇒	1.26
ROTARY EXHAUSTER	
GDP 35 LJ, GDP 40 LJ, GDP 45 MJ, GDP 50 MJ, GDP 55 MJ	2.46
ROTATING BEACON	
WITHOUT CAB	13.34
S	
SHIFT LEVER	5.34
SIDE-SHIFT CARRIAGE	
TWO AND THREE STAGE FULL FREE-LIFT	
GLP/GDP35LJ, GLP/GDP40LJ	13.42
GLP/GDP45MJ, GLP/GDP50MJ, GLP/GDP55MJ	13.44
TWO STAGE LIMITED FREE-LIFT	
GLP/GDP35LJ, GLP/GDP40LJ	13.38
GLP/GDP45MJ, GLP/GDP50MJ, GLP/GDP55MJ	13.40
SIDE-SHIFT CARRIAGE FRAME	
1219 MM TWO STAGE LIMITED FREE-LIFT	
GLP/GDP35LJ, GLP/GDP40LJ	13.46
1219 MM, TWO AND THREE STAGE FULL FREE-LIFT	
GLP/GDP35LJ, GLP/GDP40LJ	13.52
1524 MM TWO STAGE LIMITED FREE-LIFT	
GLP/GDP35LJ, GLP/GDP40LJ	13.48
1524 MM, TWO AND THREE STAGE FULL FREE-LIFT	
GLP/GDP35LJ, GLP/GDP40LJ	13.54
TWO AND THREE STAGE FULL FREE-LIFT	
GLP/GDP45MJ, GLP/GDP50MJ, GLP/GDP55MJ	13.56
TWO STAGE LIMITED FREE-LIFT	
GLP/GDP45MJ, GLP/GDP50MJ, GLP/GDP55MJ	13.50
SOUND REDUCTION	1.8
SPOT LIGHT	
WITHOUT CAB	13.32
STARTER MOTOR	
GDP35LJ, GDP40LJ, GDP45MJ, GDP50MJ, GDP55MJ	5.28
STEERING AXLE	6.6
STEERING COLUMN	6.4
STEERING CYLINDER	6.12
STEERING PUMP	6.10
STEERING SYSTEM	6.2
T	
THROTTLE LINKAGE	
GLP035LJ, GLP040LJ, GLP045MJ, GLP050MJ, GLP055MJ	4.54
WITH THROTTLE UP	
GDP35LJ, GDP40LJ, GDP45MJ, GDP50MJ, GDP55MJ	4.58
WITHOUT THROTTLE UP	
DIESEL	4.62
THROTTLE UP ASSEMBLY	4.66

DESCRIPTION	PAGE NO.
T (continued)	
TILT CYLINDER	9.32
TIMING GEAR	
GDP35LJ, GDP40LJ, GDP45MJ, GDP50MJ, GDP55MJ	2.38
TIRE AND WHEEL	
DRIVE WHEEL	
RADIAL	13.10
DUAL DRIVE WHEEL.....	13.8
SINGLE DRIVE WHEEL	
GLP/GDP35LJ, GLP/GDP40LJ.....	13.4
GLP/GDP45MJ, GLP/GDP50MJ, GLP/GDP55MJ	13.6
STEERING.....	13.14
STEERING RADIAL	
7.00 X 12 PNEUMATIC TIRE	13.16
TORQUE CONVERTER.....	8.2
TRANSMISSION	
TWO SPEED POWERSHIFT	
SHEET 1 OF 2	8.8
SHEET 2 OF 2	8.12
TRANSMISSION LINES.....	8.6
HYDROSTATIC TRANSMISSION.....	8.38
TRANSMISSION PUMP	
HYDROSTATIC TRANSMISSION.....	8.44
U	
UNDERCARRIAGE PAN	1.10
V	
VALVE	
HIGH AND LOW	8.22
HYDROSTATIC TRANSMISSION.....	8.34
VALVE COVER	
GDP35LJ, GDP40LJ, GDP45MJ, GDP50MJ, GDP55MJ	2.40
VALVE COVER AND INLET MANIFOLD	
GLP35LJ, GLP40LJ, GLP45MJ, GLP50MJ, GLP55MJ	3.34
W	
WATER SEPARATOR.....	4.16
WIRE HARNESS	
AUXILIARY LIGHTS	
WORKLIGHTS	13.83
BRAKE PRESSURE SWITCH.....	5.91
CLOSED LOOP	
⇒S/N C813A02832A	5.55
DIAGNOSTIC.....	5.57
DIESEL ENGINE	
⇒S/N C813A-02228Y	5.38
S/N C813A-02229Y⇒	5.40
ENGINE, LPG, GM V6, 4.3L	

DESCRIPTION	PAGE NO.
W (continued)	
SHEET 1 OF 2	
S/N C813A-02004Y⇔S/N C813A-02228Y	5.64
S/N C813A-02229Y⇒	5.70
SHEET 2 OF 2	
S/N C813A-02004Y⇔S/N C813A-02228Y	5.66
S/N C813A-02229Y⇒	5.72
ESOS ADAPTER	
⇒D/B 09/2001	5.56
GASOLINE ENGINE, GM V6	
SHEET 1 OF 2	
S/N C813A-02004Y⇔S/N C813A-02228Y	5.58
SHEET 2 OF 2	
S/N C813A-02004Y⇔S/N C813A-02228Y	5.60
HYDROSTATIC MODULE	5.36
LPG	
⇒S/N C813A-02004Y	5.42
LPG SWITCH	5.54
MODULE POWERSHIFT	
⇒S/N C813A02213Y	5.44
SHEET 1 OF 2	
S/N C813A02264Y⇒	5.76
SHEET 2 OF 2	
S/N C813A02264Y⇒	5.80
MODULE, TYPE S POWERSHIFT	
SHEET 1 OF 2	
S/N C813A-02014Y⇔S/N C813A-02264Y	5.84
SHEET 2 OF 2	
S/N C813A-02014Y⇔S/N C813A-02264Y	5.88
PS TRANSMISSION CONTROL	5.46
REVERSE ALARM	13.82
THROTTLE UP	
⇒S/N C813A-02486Z	5.48
S/N C813A-02487Z⇒	5.52

**SECTION 1
GENERAL TRUCK**

DESCRIPTION	PAGE
COUNTERWEIGHT	1.12
FLOOR PLATES AND COVERS	1.6
FULL SUSPENSION SEAT	
SHEET 1 OF 2	1.22
SHEET 2 OF 2	1.24
HOOD AND COVERS	1.2
LABELS	1.29
NON-SUSPENSION SEAT	1.18
OPERATOR MODULE	1.16
OVERHEAD GUARD	1.14
REAR SCREEN	
⇒S/N C813A-01588	1.20
S/N C813A-01589⇒	1.26
SOUND REDUCTION	1.8
UNDERCARRIAGE PAN	1.10

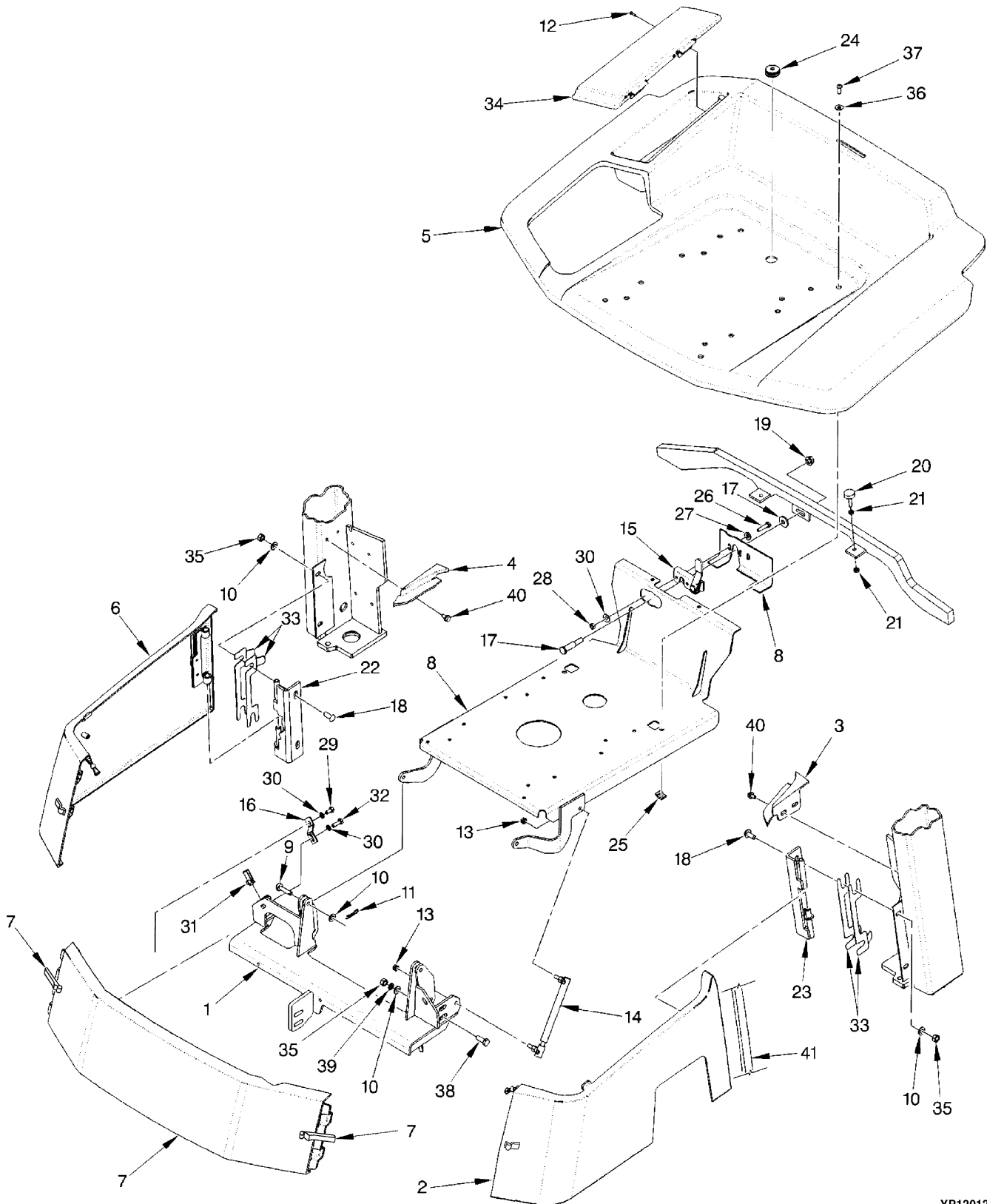

YP120123

ITEM	PART NO.	DESCRIPTION	QTY
1	504313786	Crossmember	1
2	504316732	Panel (LH, LPG) (LH) (GLP35LJ, GLP40LJ, GLP45MJ, GLP50MJ, GLP55MJ)	1
2	504316733	Panel (LH, Diesel) (LH) (GDP35LJ, GDP40LJ, GDP45MJ, GDP50MJ, GDP55MJ) ..	1
3	b 504316731	Cover (LH)	1
3	a 524143545	Cover (RH) (Not Illustrated)	1
4	b 504316730	Cover (RH)	1
4	a 524143544	Cover (LH) (Not Illustrated)	1
5	504316727	Hood (Vented)	1
6	504316726	Panel (RH)	1
7	504316725	Cover (Front)	1
7	580012765	Latch (Over Center)	2
8	504308726	Seat Pan	1
9	912326300	Pin (Hinge)	2
10	449021006	Washer	10
11	965801908	Cotter Pin	2
12	505977534	Rivet	4
13	504229298	Nut	4
14	580033641	Gas Spring Assembly	2
14	580033685	Gas Spring	1
14	580032356	Ball Stud	2
15	c 504316709	Latch Assembly	2
15	504316710	Latch	1
16	504308734	Bracket	2
17	504303790	Striker	1
18	580014430	Bolt	4
19	580008135	Nut	1
20	518790649	Stop Screw	2
21	014970800	Nut	4
22	580052055	Hinge (RH) (RH)	1
23	580014407	Hinge (LH) (LH)	1
24	518790699	Grommet	1
25	900003270	Retainer	2
26	931013907	Capscrew	2
27	504226242	Washer	2
28	449015014	Nut	2
29	449001415	Capscrew	2
30	449022016	Lockwasher	6
31	518796652	Nut	2
32	449001014	Capscrew	2
33	504316739	Shim (1,194 mm)	4
34	504317788	Door	1
35	909882404	Nut	8
36	580003569	Washer	2
37	932729905	Capscrew	2
38	449001302	Capscrew	8
39	449022013	Lockwasher	4

HOOD AND COVERS

ITEM	PART NO.	DESCRIPTION	QTY
40	504230231	Screw.....	4
41	524139011	Trim.....	2

FOOTNOTES:

- a** With Cab
- b** Without Cab
- c** ⇒ S/N C813A01695X

ITEM	PART NO.	DESCRIPTION	QTY
1	504293725	Floorplate	1
2	504293721	Floorplate	1
3	504314712	Floormat	1
4	504292798	Cover	1
5	504292799	Dash	1
6	505970526	Nut (Foldover).....	6
7	580035541	Screw.....	3
8	580035543	Screw.....	2
9	580009298	Washer	9
10	580035542	Screw.....	4
11	504317748	Flap (RH).....	1
12	504317749	Flap (LH).....	1
13	580007199	Washer	6
14	449001134	Capscrew.....	6
15	449021001	Washer	6
16	449015098	Locknut.....	6
17	580010272	Cover	2
18	504310722	Cover (Radiator) (Overhead Exhaust)	1
18	504292784	Cover (Radiator) (Counterweight Exhaust).....	1
19	a 504308785	Door (Radiator Cap)	1
19	a 504310723	Door (Radiator Cap) (Radiator Cap).....	1
20	580011980	Capscrew.....	3
21	580003569	Washer	3
22	580011736	Lanyard.....	1
23	580013716	Screw.....	1
24	449015112	Nut.....	1
25	015416200	Cotter Pin	1
26	449021003	Washer	1

FOOTNOTES:

a GDP35LJ, GDP40LJ, GDP45MJ, GDP50MJ, GDP55MJ

SOUND REDUCTION

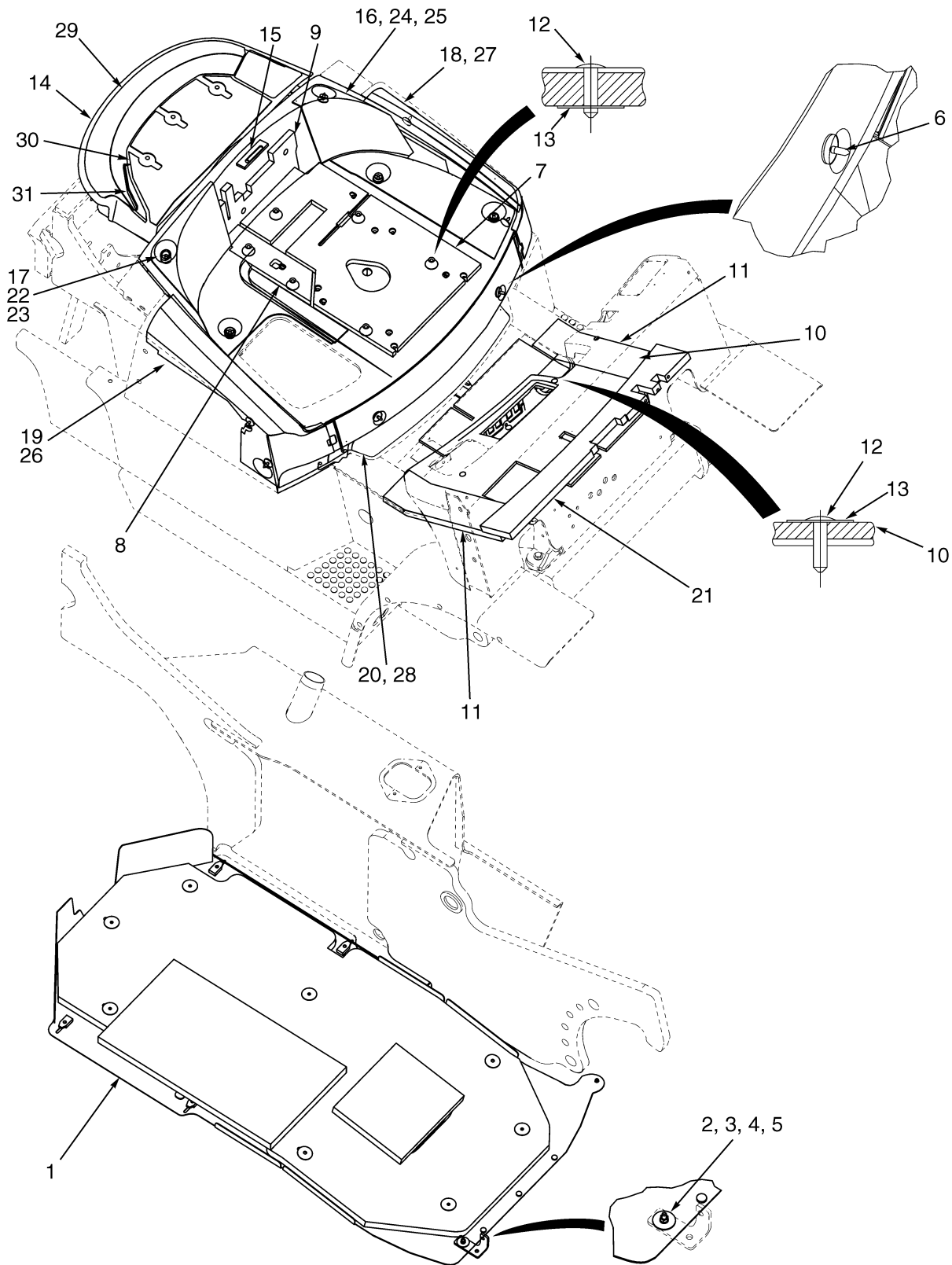

YP120566



KEY:

A: 1830 mm Short Wheel Base

B: 2100 mm Long Wheel Base

ITEM	PART NO.	DESCRIPTION	QTY	
			A	B
1	580011017	Undercarriage Pan (☞ Page 1.10)	1	..
1	580011018	Undercarriage Pan (☞ Page 1.10)	1
2	580001471	Capscrew	1	1
3	580001698	Washer	2	2
4	449022018	Lockwasher	1	1
5	449015002	Nut.....	1	1
6	518793609	Fastener	12	12
7	580014100	Sound Liner (Seat)	1	1
8	580014101	Sound Liner (Seat)	1	1
9	580014102	Sound Liner (Seat)	1	1
10	580014103	Sound Liner (Floor Plate)	1	1
11	580014104	Sound Liner (Floor Plate)	2	2
12	580011023	Rivet	15	15
13	580013498	Washer	15	15
14	580032782	Seal	AR	AR
15	580032783	Pad	1	1
16	504323772	Liner (Hood LH).....	1	1
17	504323773	Liner (Hood RH).....	1	1
18	504323774	Liner (Door LH)	1	1
19	504323775	Liner (Door RH).....	1	1
20	504323776	Liner (Front Cover)	1	1
21	524139698	Cowl Barrier	1	1
22	524139468	Seat Panel (RH)	1	1
23	524139469	Seat Panel (RH)	1	1
24	524139470	Seat Panel (LH).....	1	1
25	524139471	Seat Panel (LH).....	1	1
26	524139472	Door Panel (RH).....	1	1
27	524139473	Door Panel (LH)	1	1
28	524139474	Panel (Front)	1	1
29	524139700	Sound Liner (Radiator Cover)	1	1
30	524139701	Sound Barrier (Radiator Cover)	1	1
31	524139702	Foam Block	1	1
	524139699	Barrier Kit (Includes Items 22-28).....	1	1

UNDERCARRIAGE PAN

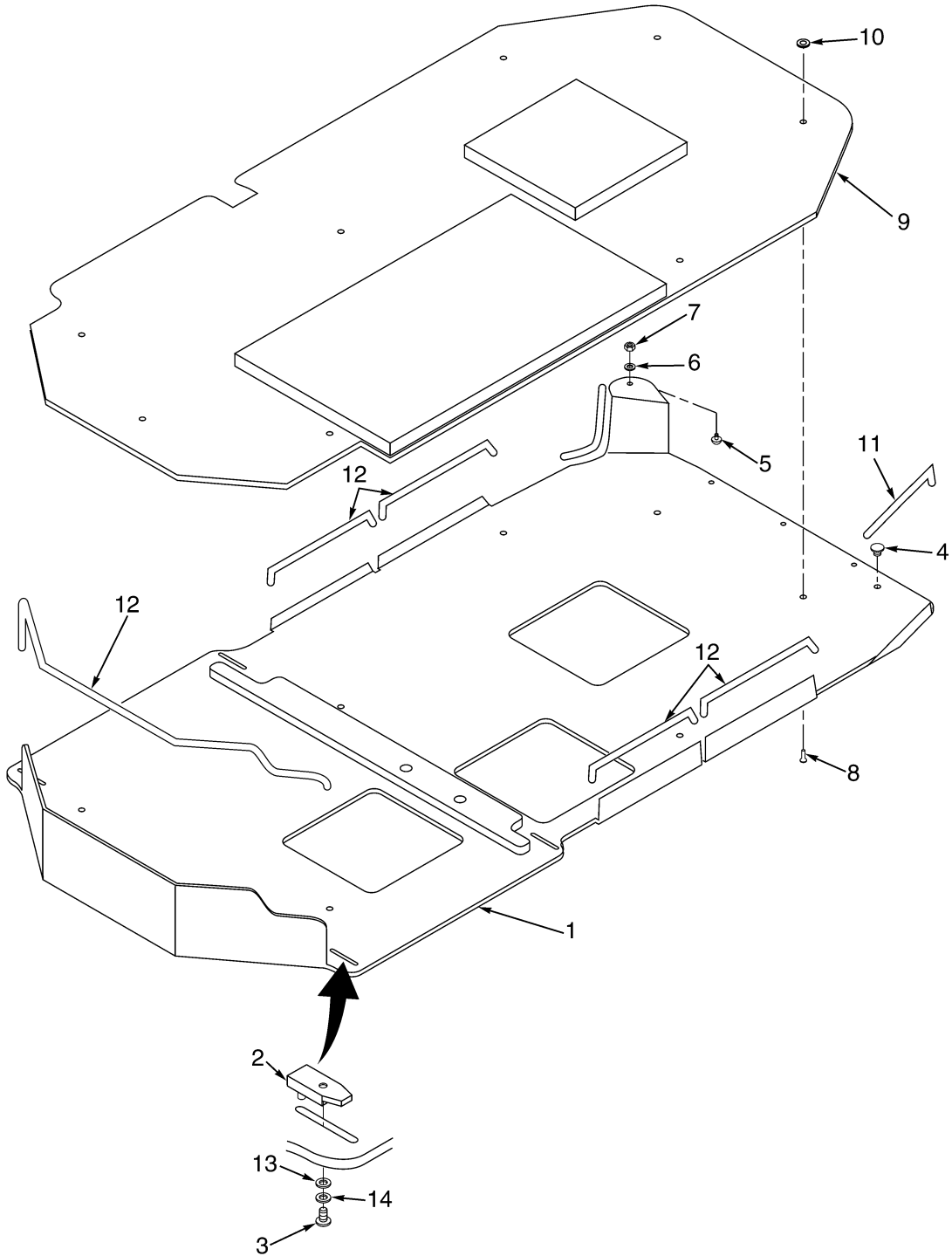

HP120636

KEY:

A: 1830 mm Short Wheel Base

B: 2100 mm Long Wheel Base

ITEM	PART NO.	DESCRIPTION	QTY	
			A	B
	580011017	Undercarriage Pan (Assembly)	1	..
	580011018	Undercarriage Pan (Assembly)	1
1	580013496	Pan	1	..
1	580013497	Pan	1
2	580011026	Nut.....	4	6
3	580011028	Capscrew	4	6
4	580011025	Bumper.....	3	3
5	580011024	Screw	1	1
6	449021002	Washer	1	1
7	449015112	Nut.....	1	1
8	580011023	Rivet	8	8
9	580011021	Liner	1	..
9	580011022	Liner	1
10	580013498	Washer	8	8
11	580011030	Edge Strip (250 mm).....	2	2
12	580011031	Edge Strip (420 mm).....	4	4
13	449021003	Washer	4	6
14	449022018	Lockwasher	4	6

COUNTERWEIGHT

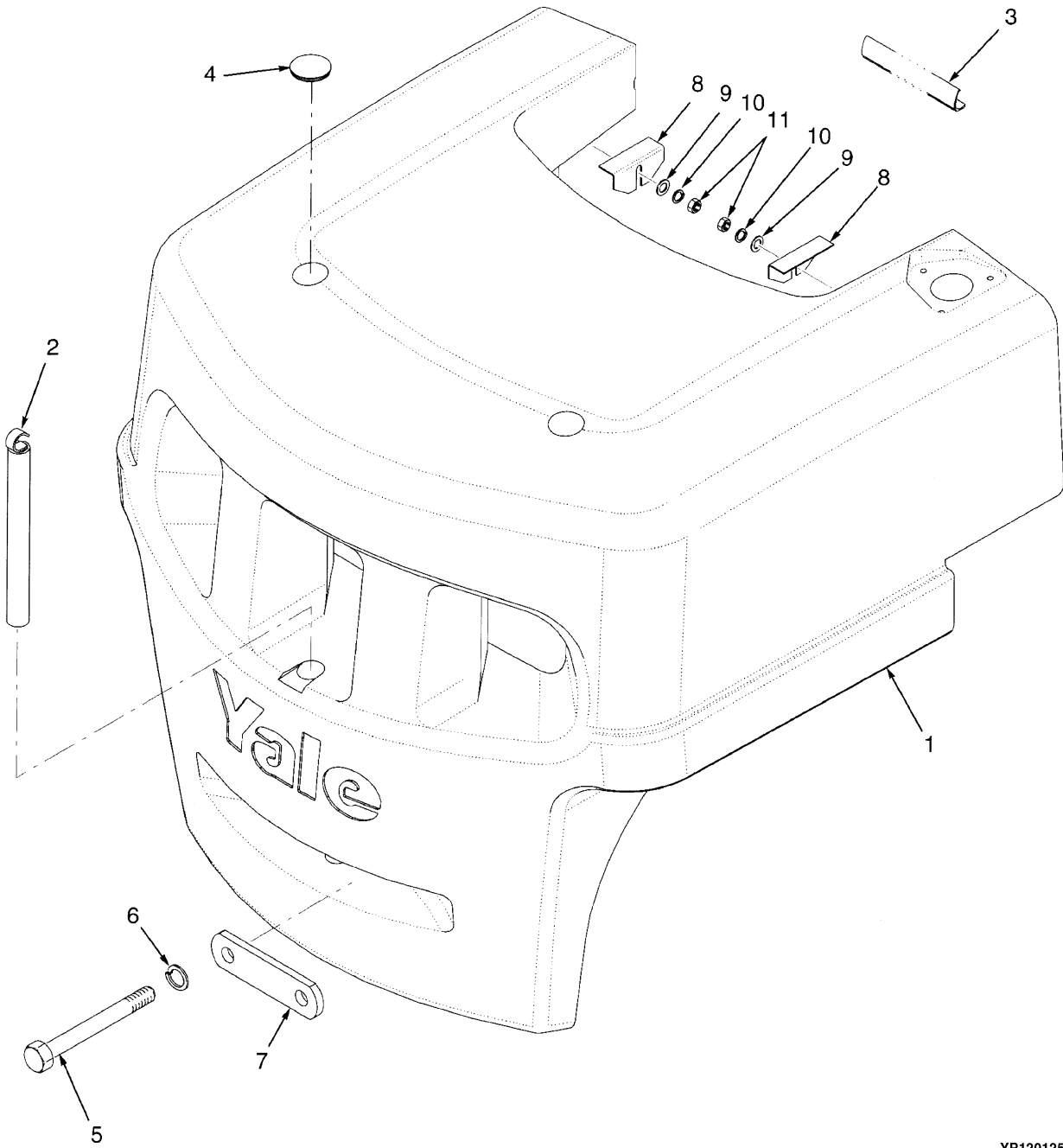

YP120125



Suggest:

For more complete manuals. Please go to the home page.

<https://www.ebooklibonline.com>

If the above button click is invalid. Please download this document first, and then click the above link to download the complete manual.

Thank you so much for reading

ITEM	PART NO.	DESCRIPTION	QTY
1	504294725	Counterweight (GLP/GDP35LJ)	1
1	504294726	Counterweight (GLP/GDP40LJ)	1
1	504294728	Counterweight (GLP/GDP45MJ)	1
1	504294729	Counterweight (GLP/GDP50MJ)	1
1	504294730	Counterweight (GLP/GDP55MJ)	1
2	504294746	Tow Pin	1
3	580010392	Seal (GLP/GDP35LJ, GLP/GDP40LJ)	2
3	580010394	Seal (GLP/GDP45MJ, GLP/GDP50MJ, GLP/GDP55MJ)	2
4	925776402	Cap	2
5	449001409	Capscrew	2
6	955400911	Lockwasher	2
7	580017374	Washer	1
8	505970557	Shim (2,769 mm)	4
9	504226242	Washer	4
10	449022016	Lockwasher	4
11	449015014	Nut	2

OVERHEAD GUARD

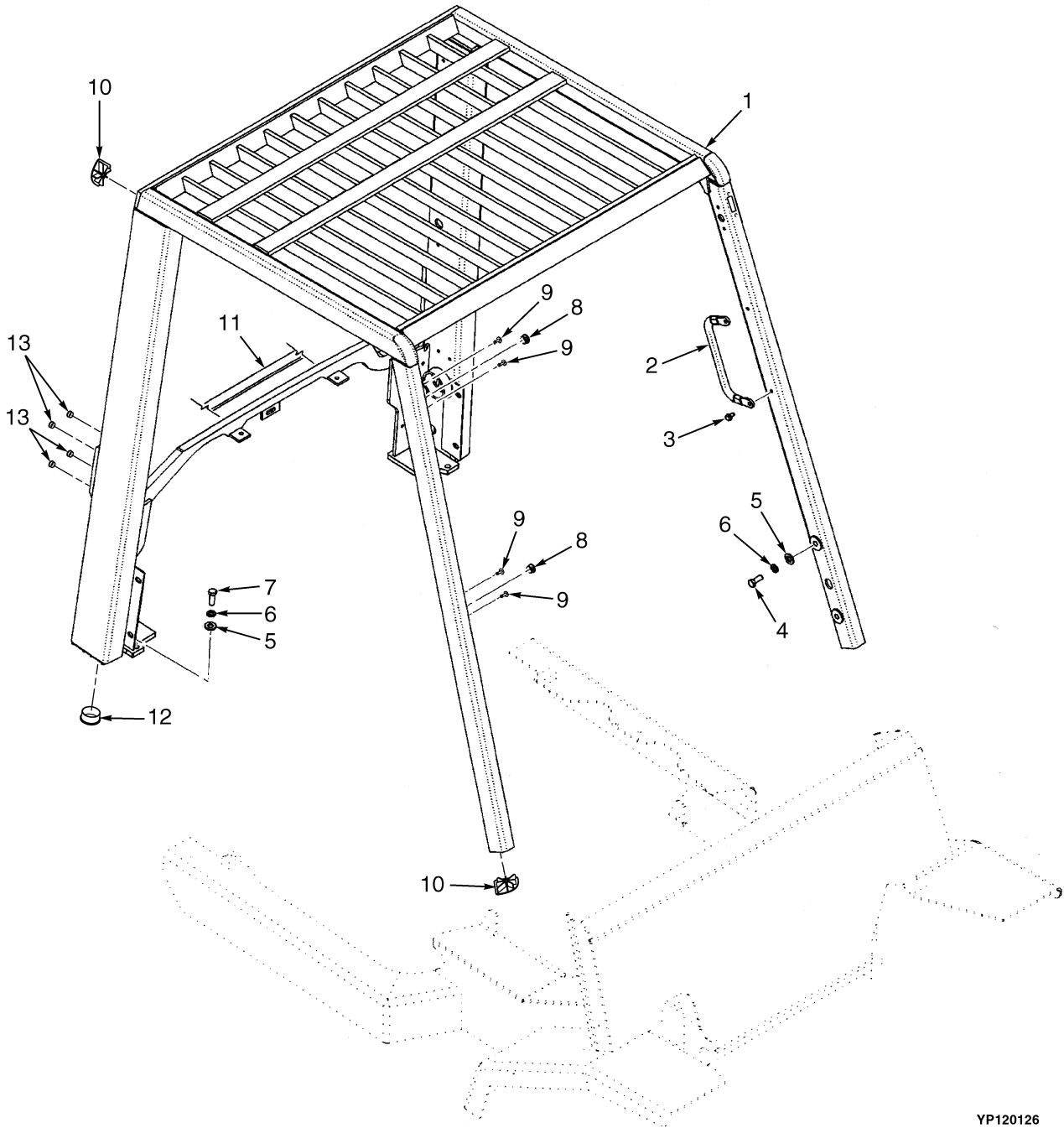

YP120126

<https://www.ebooklibonline.com>

Hello dear friend!

Thank you very much for reading.

Enter the link into your browser.

The full manual is available for immediate download.

<https://www.ebooklibonline.com>