

GDP/GLP16-18VX, GDP/GLP20SVX

**VERACITOR
(C810)**

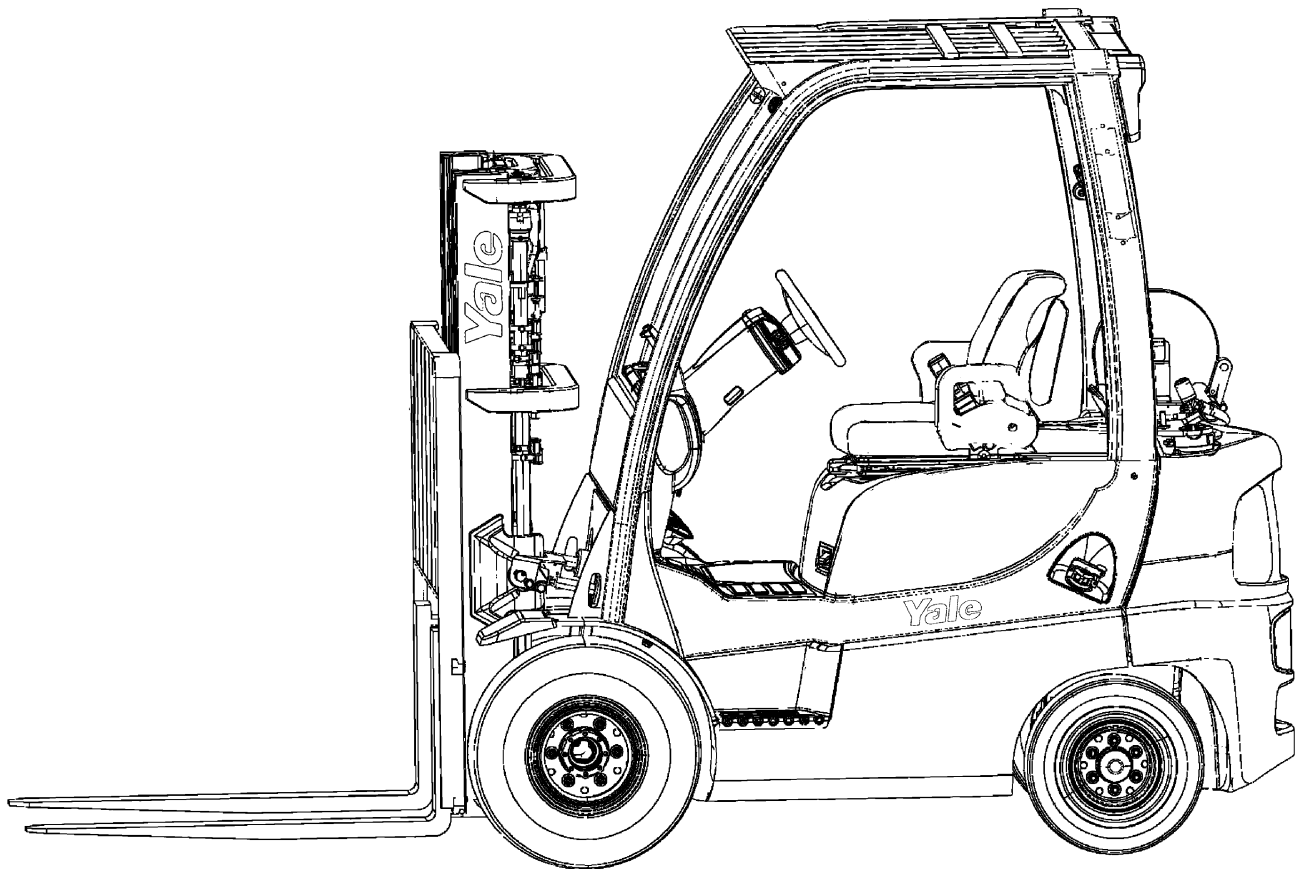

1	GENERAL TRUCK
2	DIESEL ENGINE
3	LPG ENGINE (2.0L)
4	FUEL SYSTEM
5	ELECTRICAL SYSTEM
6	STEERING SYSTEM
7	BRAKE SYSTEM
8	TRANSMISSION
9	HYDRAULIC SYSTEM
10	MAST-TWO STAGE LIMITED FREE-LIFT
11	MAST-THREE STAGE FULL FREE-LIFT
12	MAST-TWO STAGE FULL FREE-LIFT
13	FORKS, LOAD BACKREST, AND MAST INSTALLATION
14	ATTACHMENTS AND HEADER HOSE GROUP
15	OPTIONS
16	NUMERICAL INDEX

ALPHABETICAL INDEX

DESCRIPTION	PAGE NO.
A	
ABBREVIATIONS QUICK REFERENCE SHEET	ix
AIR CLEANER FILTER ASSEMBLY	4.8
AIR CLEANER SYSTEM	
DIESEL	4.4
LPG	
MAZDA 2.0L	4.2
ALPHABETICAL INDEX	i
ALTERNATOR AND MOUNTING	
YANMAR 2.6L DIESEL	5.35
AUXILIARY TUBE EXTENSIONS	
TWO STAGE FULL FREE-LIFT AND THREE STAGE FULL FREE-LIFT	14.28
TWO STAGE LIMITED FREE-LIFT	14.26
AUXILIARY ONE SECTION	
ELECTRONIC CONTROL	
THREE AND FOUR FUNCTION	9.34
AUXILIARY SECTIONS ONE AND TWO	
MANUAL CONTROL	
THREE AND FOUR FUNCTION	9.22
AUXILIARY TWO SECTION	
ELECTRONIC CONTROL	
FOUR FUNCTION	9.36
B	
BACK-UP ALARM	15.2
BRAKE ASSEMBLY	7.6
BRAKE LINKAGE	
DUAL PEDAL	7.4
SINGLE PEDAL	7.2
C	
CAMSHAFT AND DRIVE GEAR	
YANMAR 2.6L DIESEL	2.24
CAMSHAFT AND VALVES	
MAZDA 2.0L	3.28
CARRIAGE	
THREE STAGE FULL FREE-LIFT	14.12
TWO STAGE FULL FREE-LIFT	14.6
TWO STAGE LIMITED FREE-LIFT	14.2
CONTROL LEVER LABELS	1.32
CONTROL VALVE	
TRANSMISSION	8.16
CONTROL VALVE ASSEMBLY	
ELECTRONIC CONTROL	
THREE AND FOUR FUNCTION	9.25
MANUAL CONTROL	
THREE AND FOUR FUNCTION	9.18

<https://www.ebooklibonline.com>

Hello dear friend!

Thank you very much for reading.

Enter the link into your browser.

The full manual is available for immediate download.

<https://www.ebooklibonline.com>

DESCRIPTION	PAGE NO.
C (continued)	
COOLING	
MAZDA 2.0L	3.4
YANMAR 2.6L DIESEL	2.6
COUNTERWEIGHT	1.12
COUNTERWEIGHT EXHAUST	
MAZDA 2.0L	
WITH CATALYTIC CONVERTER	3.12
COWL ELECTRICAL	5.18
COWL MOUNTING	1.10
CRANKSHAFT AND PISTONS	
MAZDA 2.0L	3.30
YANMAR 2.6L DIESEL	2.26
CYLINDER BLOCK	
MAZDA 2.0L	3.32
YANMAR 2.6L DIESEL	2.28
CYLINDER HEAD	
MAZDA 2.0L	3.26
YANMAR 2.6L DIESEL	2.20
D	
DISTRIBUTER	
MAZDA 2.0L	5.34
DRIVE AXLE	8.18
DRIVE TIRES AND WHEELS	8.21
PNEUMATIC RADIAL	8.22
E	
ELECTRICAL SYSTEM	
CHASSIS	5.4
ELECTRO HYDRAULIC POPPET VALVE	
ELECTRONIC CONTROL	
HOIST AND LOWER	9.32
ELECTRONIC LEVER LABELS	
AUXILIARY DUAL FUNCTION	1.36
AUXILIARY SINGLE FUNCTION	1.34
ELECTRONIC THROTTLE LINKAGE	
DIESEL	4.36
ENGINE ELECTRICAL COMPONENTS	
MAZDA 2.0L	5.8
ENGINE ELECTRICAL SYSTEM	
MAZDA 2.0L	5.10
YANMAR 2.6L DIESEL	5.14
ENGINE FUEL SYSTEM AND EMISSION CONTROL	
MAZDA 2.0L	3.16
ENGINE MOUNTING	
MAZDA 2.0L	3.2
YANMAR 2.6L DIESEL	2.2
EXHAUST	

DESCRIPTION	PAGE NO.
E (continued)	
WITH PURIFIER	
YANMAR 2.6L DIESEL.....	2.8
WITHOUT PURIFIER	
YANMAR 2.6L DIESEL.....	2.10
F	
FAN ASSEMBLY	
YANMAR 2.6L DIESEL.....	2.4
FENDER EXTENSIONS AND MUD GUARDS	
WITH WIDE TREAD.....	1.8
FLOORPLATES AND COVERS.....	1.4
FLYWHEEL AND HOUSING	
MAZDA 2.0L.....	3.18
YANMAR 2.6L DIESEL.....	2.14
FOOT DIRECTIONAL CONTROL PEDAL ASSEMBLY.....	4.38
FORKS.....	13.2
OPTIONAL.....	13.3
FORWARD CLUTCH	
INPUT.....	8.12
FREE-LIFT	
THREE STAGE FULL FREE-LIFT.....	11.16
TWO STAGE FULL FREE-LIFT.....	12.12
FREE-LIFT CYLINDER	
THREE STAGE FULL FREE-LIFT.....	11.18
TWO STAGE FULL FREE-LIFT.....	12.14
FUEL FILTER	
YANMAR 2.6L DIESEL.....	4.28
FUEL INJECTION	
YANMAR 2.6L DIESEL.....	4.30
FUEL SYSTEM	
LPG	
MAZDA 2.0L.....	4.10
YANMAR DIESEL.....	4.26
FULL SUSPENSION SEAT	
WITH AND WITHOUT ELECTRONIC CONTROLS.....	1.20
WITH LIMITED BACK TILT	
PENDING PER ECN 10419483⇒.....	1.24
FULL SUSPENSION SWIVEL SEAT	
WITH AND WITHOUT ELECTRONIC CONTROLS.....	1.22
WITH LIMITED BACK TILT	
PENDING PER ECN 10411763⇒.....	1.26
G	
GEAR HOUSING	
YANMAR 2.6L DIESEL.....	2.16
GEAR PUMP	
MAZDA 2.0L.....	9.6
YANMAR DIESEL.....	9.7

DESCRIPTION	PAGE NO.
H	
HAND LEVERS	
FOUR FUNCTION	
WITH DETENTED LEVERS.....	9.16
WITHOUT DETENTED LEVERS.....	9.14
THREE FUNCTION	
WITH DETENTED LEVERS.....	9.12
WITHOUT DETENTED LEVERS.....	9.10
HEADER HOSES	
THREE STAGE FULL FREE-LIFT.....	14.14
TWO STAGE FULL FREE-LIFT.....	14.8
TWO STAGE LIMITED FREE-LIFT.....	14.4
HOOD.....	1.2
HOW TO FIND THE DESIRED PART NUMBER.....	xi
HOW TO USE THE ILLUSTRATED PARTS MANUAL.....	xi
HYDRAULIC FILTER.....	9.8
HYDRAULIC SUPPLY AND RETURN.....	9.2
I	
IDENTIFICATION OF ATTACHMENT AND SIDE-SHIFT CARRIAGE SERIAL NUMBERS.....	xiv
IDENTIFICATION OF MAST SERIAL NUMBER.....	xiii
IDENTIFICATION OF TRUCK SERIAL NUMBER.....	xii
IMPACT SENSOR.....	5.6
INNER MAST	
THREE STAGE FULL FREE-LIFT.....	11.6
TWO STAGE FULL FREE-LIFT.....	12.4
TWO STAGE LIMITED FREE-LIFT.....	10.4
INSTRUMENT CLUSTER.....	5.22
INTAKE AND EXHAUST MANIFOLDS	
MAZDA 2.0L.....	3.14
YANMAR 2.6L DIESEL.....	2.12
INTEGRAL SIDE-SHIFT ASSEMBLY	
TWO STAGE FULL FREE-LIFT AND THREE STAGE FULL FREE-LIFT.....	14.20
TWO STAGE LIMITED FREE-LIFT.....	14.18
INTEGRAL SIDE-SHIFT CYLINDER.....	14.22
INTEGRAL SIDE-SHIFT HYDRAULIC HOSES	
TWO STAGE FULL FREE-LIFT AND THREE STAGE FULL FREE-LIFT.....	14.24
TWO STAGE LIMITED FREE-LIFT.....	14.23
INTERMEDIATE MAST	
THREE STAGE FULL FREE-LIFT.....	11.4
J	
JOYSTICK AND ELECTRONIC CONTROL LEVERS.....	5.24
JOYSTICK LABELS.....	1.38
WITH RETURN TO SET TILT.....	1.40

DESCRIPTION	PAGE NO.
L	
LABELS	
EXTERIOR.....	1.28
INTERIOR.....	1.30
LOAD BACKREST EXTENSION.....	13.4
LOAD WEIGH ELECTRICAL	5.32
LPG BRACKET	
SWING OUT, DROP DOWN	
⇒PENDING PER ECN 10419468	4.18
LPG TANK BRACKET	
SWING OUT	
⇒PENDING PER ECN 10419468	4.14
SWING OUT, WITH FABRIC STRAP	
PENDING PER ECN 10419468⇒	4.16
SWING OUT/DROP DOWN	
PENDING PER ECN 10419468⇒	4.22
LUBRICATION SYSTEM	
YANMAR 2.6L DIESEL	2.32
M	
MAIN LIFT	
THREE STAGE FULL FREE-LIFT	11.8
TWO STAGE FULL FREE-LIFT	12.6
TWO STAGE LIMITED FREE-LIFT.....	10.6
MAIN LIFT CYLINDER	
LEFT HAND	
THREE STAGE FULL FREE-LIFT	11.14
TWO STAGE FULL FREE-LIFT	12.10
TWO STAGE LIMITED FREE-LIFT	10.10
RIGHT HAND	
THREE STAGE FULL FREE-LIFT	11.12
TWO STAGE FULL FREE-LIFT	12.8
TWO STAGE LIMITED FREE-LIFT	10.8
MAST ELECTRICAL	
TILT SENSOR.....	5.30
MAST INSTALLATION.....	13.6
MIRRORS.....	15.4
N	
NON SUSPENSION SEAT	
WITHOUT ELECTRONIC CONTROLS	1.16
O	
OIL PAN	
YANMAR 2.6L DIESEL	2.18
OIL PUMP AND FILTER	
MAZDA 2.0L	3.24
OUTER MAST	
THREE STAGE FULL FREE-LIFT	11.2
TWO STAGE FULL FREE-LIFT	12.2

DESCRIPTION	PAGE NO.
O (continued)	
TWO STAGE LIMITED FREE-LIFT	10.2
OUTLET SECTION	
ELECTRONIC CONTROL	
THREE AND FOUR FUNCTION	9.38
MANUAL CONTROL	
THREE AND FOUR FUNCTION	9.24
OVERHEAD EXHAUST	
MAZDA 2.0L	
WITH CATALYTIC CONVERTER	3.10
WITHOUT CATALYTIC CONVERTER	
S/N C810B01820D⇒	3.8
⇒S/N C810B04819D	3.6
OVERHEAD GUARD	1.14
P	
PARK BRAKE	7.8
POWER DISTRIBUTION MODULE	
PENDING PER ECN 10419489⇒	5.21
⇒PENDING PER ECN 10419489	5.20
PRE-CLEANER AND MOUNT	4.6
R	
REVERSE CLUTCH	
COUNTER	8.14
S	
SEMI SUSPENSION SEAT	
WITH AND WITHOUT ELECTRONIC CONTROLS	1.18
STEER TIRES AND WHEELS	6.11
STEERING AXLE	6.8
STEERING COLUMN ASSEMBLY	6.4
STEERING CONTROL UNIT	6.6
STEERING CYLINDER	6.10
STEERING SYSTEM	6.2
T	
THROTTLE CABLE LINKAGE	
DIESEL	4.34
THROTTLE LINKAGE	
LPG	4.32
TILT AND AUXILIARY HOSES	9.4
TILT CYLINDERS	
LEFT HAND	9.42
RIGHT HAND	9.40
TILT SECTION	
ELECTRONIC CONTROL	
THREE AND FOUR FUNCTION	9.30

DESCRIPTION	PAGE NO.
T (continued)	
TIMING GEAR COVER AND OIL PAN	
MAZDA 2.0L	3.22
TORQUE CONVERTER.....	8.3
TRANSMISSION	
SINGLE SPEED	
SHEET 1 OF 2	8.8
SHEET 2 OF 2	8.10
TRANSMISSION COOLING	
MAZDA 2.0L	8.4
YANMAR 2.6L DIESEL	8.6
TRANSMISSION ELECTRICAL SYSTEM	5.28
TRANSMISSION MOUNT	8.2
V	
VALVE ASSEMBLY	
LIFT AND TILT	
MANUAL CONTROL, THREE AND FOUR FUNCTION	9.20
VALVE ASSEMBLY, LIFT AND LOWER	
ELECTRONIC CONTROL	
THREE AND FOUR FUNCTION.....	9.28
W	
WATER PUMP	
MAZDA 2.0L	3.20
YANMAR 2.6L DIESEL	2.30
WIRE HARNESS	
BACK-UP ALARM.....	15.5
CHASSIS	
MAZDA 2.0L.....	5.36
YANMAR 2.6L DIESEL	
⇒D/B 08/2006	5.48
COWL WITH FOOT DIRECTIONAL CONTROL PEDAL	
WITH RETURN TO SET TILT	5.60
COWL WITH FORWARD/REVERSE LEVER	
WITHOUT RETURN TO SET TILT.....	5.64
DIESEL ENGINE	
YANMAR 2.6L	
D/B 08/2006⇒	5.74 5.74
ELECTRONIC CONTROL VALVE	
THREE FUNCTION.....	5.76
ELECTRONIC CONTROL VALVE	
FOUR FUNCTION.....	5.78
LIGHTS.....	5.84
LPG ENGINE	
MAZDA 2.0L	
D/B 08/2006⇒	5.70
⇒D/B 08/2006	5.68
RH CHASSIS	

DESCRIPTION	PAGE NO.
-------------	----------

W (continued)

MAZDA 2.0L	
D/B 08/2006⇒	5.42
YANMAR 2.6L	
D/B 08/2006⇒	5.54
TRANSMISSION	
SINGLE SPEED	
D/B 08/2006⇒	5.82
⇒D/B 08/2006	5.80
WORK, REAR DRIVE, AND BRAKE/TAIL LIGHTS	5.26

**SECTION 1
GENERAL TRUCK**

DESCRIPTION	PAGE
CONTROL LEVER LABELS.....	1.32
COUNTERWEIGHT	1.12
COWL MOUNTING	1.10
ELECTRONIC LEVER LABELS	
AUXILIARY DUAL FUNCTION	1.36
AUXILIARY SINGLE FUNCTION.....	1.34
FENDER EXTENSIONS AND MUD GUARDS	
WITH WIDE TREAD	1.8
FLOORPLATES AND COVERS	1.4
FULL SUSPENSION SEAT	
WITH AND WITHOUT ELECTRONIC CONTROLS	1.20
WITH LIMITED BACK TILT	
PENDING PER ECN 10419483⇒	1.24
FULL SUSPENSION SWIVEL SEAT	
WITH AND WITHOUT ELECTRONIC CONTROLS	1.22
WITH LIMITED BACK TILT	
PENDING PER ECN 10411763⇒	1.26
HOOD.....	1.2
JOYSTICK LABELS.....	1.38
WITH RETURN TO SET TILT	1.40
LABELS	
EXTERIOR.....	1.28
INTERIOR.....	1.30
NON SUSPENSION SEAT	
WITHOUT ELECTRONIC CONTROLS	1.16
OVERHEAD GUARD.....	1.14
SEMI SUSPENSION SEAT	
WITH AND WITHOUT ELECTRONIC CONTROLS	1.18

HOOD

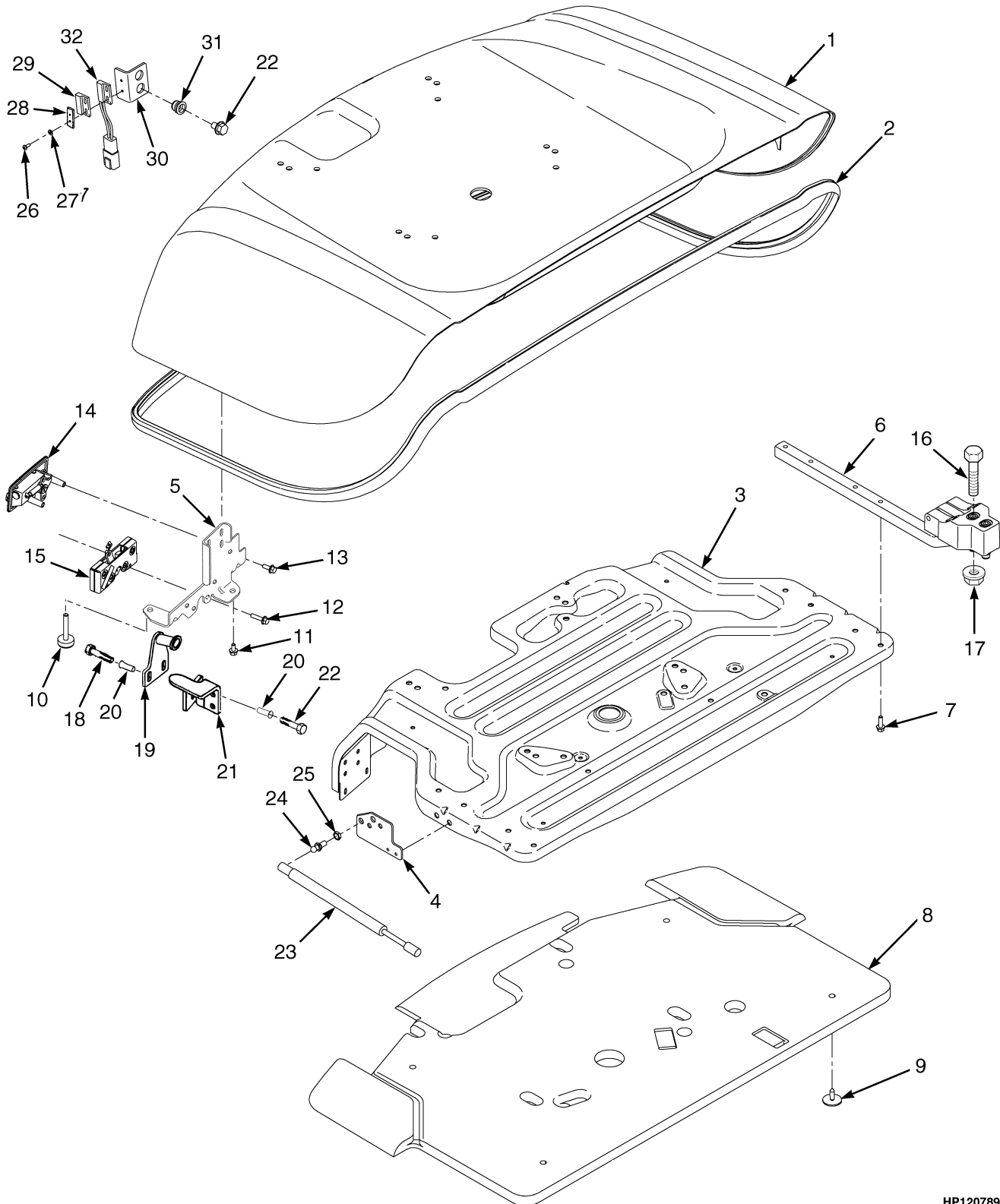

HP120789

ITEM	PART NO.	DESCRIPTION	QTY
1	524255485	Hood.....	1
2	580054201	Seal (Hood).....	1
3	580066552	Reinforcement Assembly.....	1
4	580065388	Bracket (Gas Spring Mount).....	2
5	580056737	Plate.....	1
6	580054196	Hinge.....	2
7	580030966	Capscrew.....	10
8	580070140	Liner.....	1
9	518793609	Fastener.....	4
10	580058383	Bumper (Hood).....	2
11	580039900	Capscrew.....	6
12	580049840	Capscrew.....	4
13	580049011	Capscrew.....	2
14	580056434	Handle.....	1
15	580056433	Latch Rotor.....	1
16	580023008	Capscrew.....	4
17	580027572	Nut.....	4
18	580049229	Capscrew.....	2
19	580056853	Striker Bolt.....	1
20	580044860	Insert.....	4
21	580065890	Bumper Rest.....	1
22	580056815	Capscrew.....	4
23	580056664	Gas Spring (Without Cab).....	2
23	580060004	Gas Spring (LH) (With Cab).....	1
23	580060007	Gas Spring (RH) (With Cab).....	1
24	580049915	Ball Stud (Without Cab).....	4
24	580064627	Ball Stud (With Cab , LH).....	1
24	580049915	Ball Stud (With Cab).....	3
25	580004592	Nut.....	2
26	449007034	Screw.....	4
27	940004902	Washer.....	4
28	580057864	Plate.....	1
29	580051442	Magnet.....	1
30	580056665	Bracket (Hood Switch).....	2
31	580044861	Insert.....	2
32	580071587	Reed Switch.....	1
	580049758	Fastener (Not Illustrated).....	8
	580051832	Grommet (Not Illustrated).....	1
	524255979	Plug (Gold) (Not Illustrated).....	1

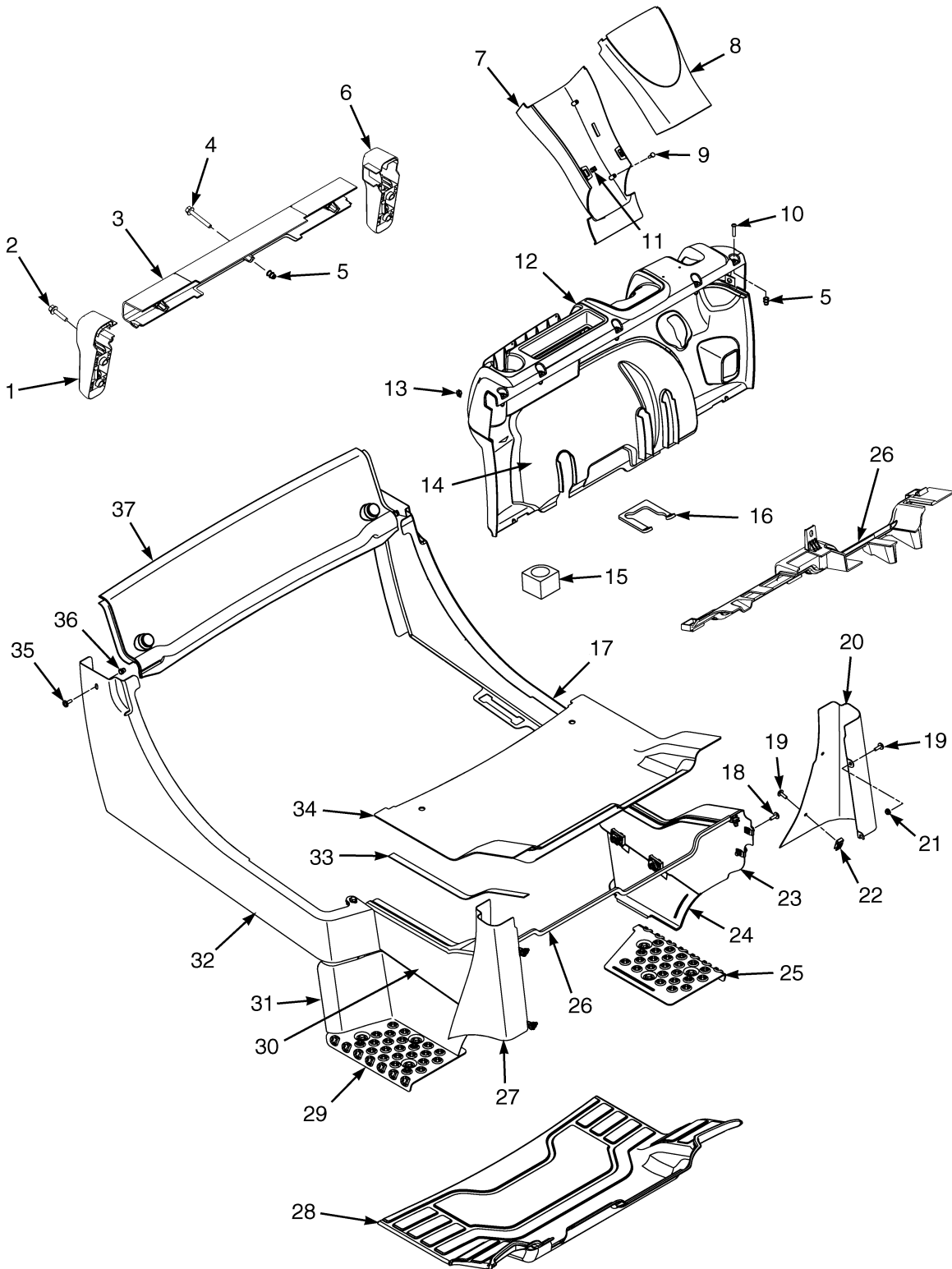

ITEM	PART NO.	DESCRIPTION	QTY
1	580037206	Bracket (Tail Light) (RH)	1
2	580058212	Capscrew.....	4
3	580048561	Cover (Rear) (Crossmember).....	1
4	580041711	Capscrew.....	3
5	580044859	Insert	8
6	580037205	Bracket (Tail Light) (LH).....	1
7	580046138	Cover (Steering Column) (Lower).....	1
8	580046143	Cover (Steering Column) (Upper).....	1
9	909904403	Screw.....	2
10	932728908	Capscrew.....	5
11	580046139	Clip	2
12	580052909	Dash Assembly (Electronic Hydraulics).....	1
12	Dash.....	1
12	580052409	Cup Holder.....	1
12	580052910	Dash Assembly (Manual Valve).....	1
12	Dash.....	1
12	580052409	Cup Holder.....	1
13	580046139	Clip	4
14	580053146	Panel (Kick) (Single Pedal).....	1
14	580053147	Panel (Kick) (Dual Pedal).....	1
15	580038033	Grommet (RH) (Foam)	1
16	580055698	Seal	1
17	a 524177724	Panel (Rear) (LH)	1
17	b 524177725	Panel (Rear) (LH)	1
18	580056815	Capscrew.....	2
19	580056530	Screw.....	8
20	524211686	Cover (Fender) (LH)	1
21	580047919	Nut (Flange).....	4
22	505970526	Nut (Foldover).....	4
23	524188740	Panel (Front) (LH).....	1
24	524220651	Panel (Step) (LH).....	1
25	580048439	Plate (Tread) (LH).....	1
26	580056531	Seal Plate Assembly.....	1
26	580045192	Seal	1
27	524211687	Cover (Fender) (RH).....	1
28	580054070	Floormat	1
29	580048440	Plate (Tread) (RH)	1
30	524188740	Panel (Front) (RH)	1
31	524220652	Panel (Step) (RH)	1
32	524177726	Panel (Rear) (RH).....	1
33	580050773	Seal	2
34	580038024	Floor Plate	1
35	580056530	Screw.....	2
36	580041704	Insert	6
37	524195752	Cover Assembly (Radiator).....	1

FLOORPLATES AND COVERS

ITEM	PART NO.	DESCRIPTION	QTY
38	580061815	Seal (LH)	1
38	580061814	Seal (RH)	1

FOOTNOTES:

- a Diesel
- b LPG

FENDER EXTENSIONS AND MUD GUARDS (WITH WIDE TREAD)

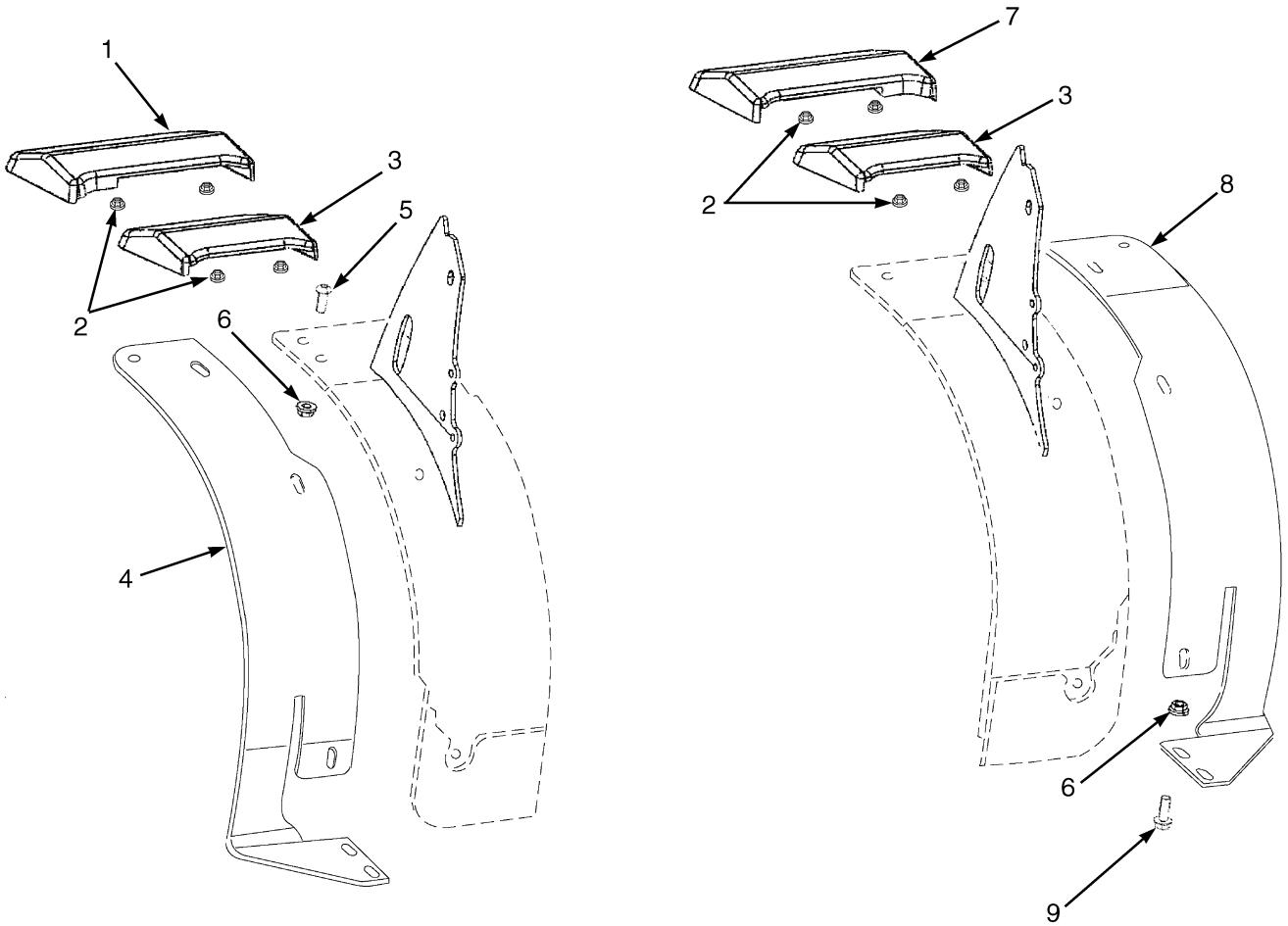



FENDER EXTENSIONS AND MUD GUARDS
(WITH WIDE TREAD)

ITEM	PART NO.	DESCRIPTION	QTY
1	580051157	Mud Guard (Wide, RH).....	1
2	580042963	Lock Nut	4
3	580050478	Mud Guard (Standard).....	2
4	524205232	Fender (Extension, RH).....	1
5	932731906	Capscrew.....	4
6	580058192	Nut.....	10
7	580051156	Mud Guard (Wide, LH)	1
8	524205117	Fender (Extension, LH)	1
9	580058271	Capscrew.....	6

COWL MOUNTING

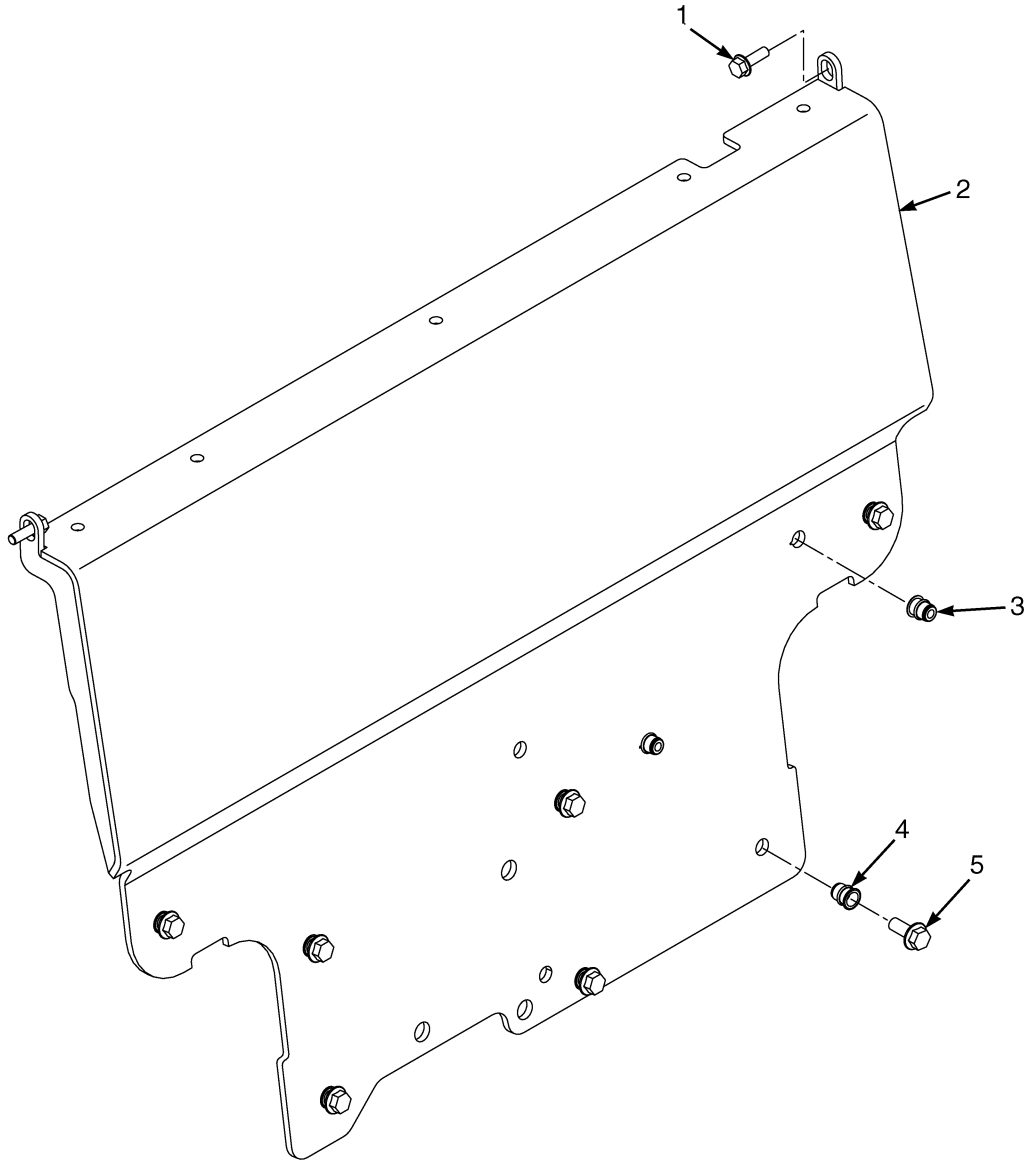

HP120730

ITEM	PART NO.	DESCRIPTION	QTY
1	580056815	Capscrew.....	2
2	524215812	Cowl.....	1
3	580044860	Insert	2
4	580044862	Insert	7
5	580064483	Capscrew.....	7

COUNTERWEIGHT

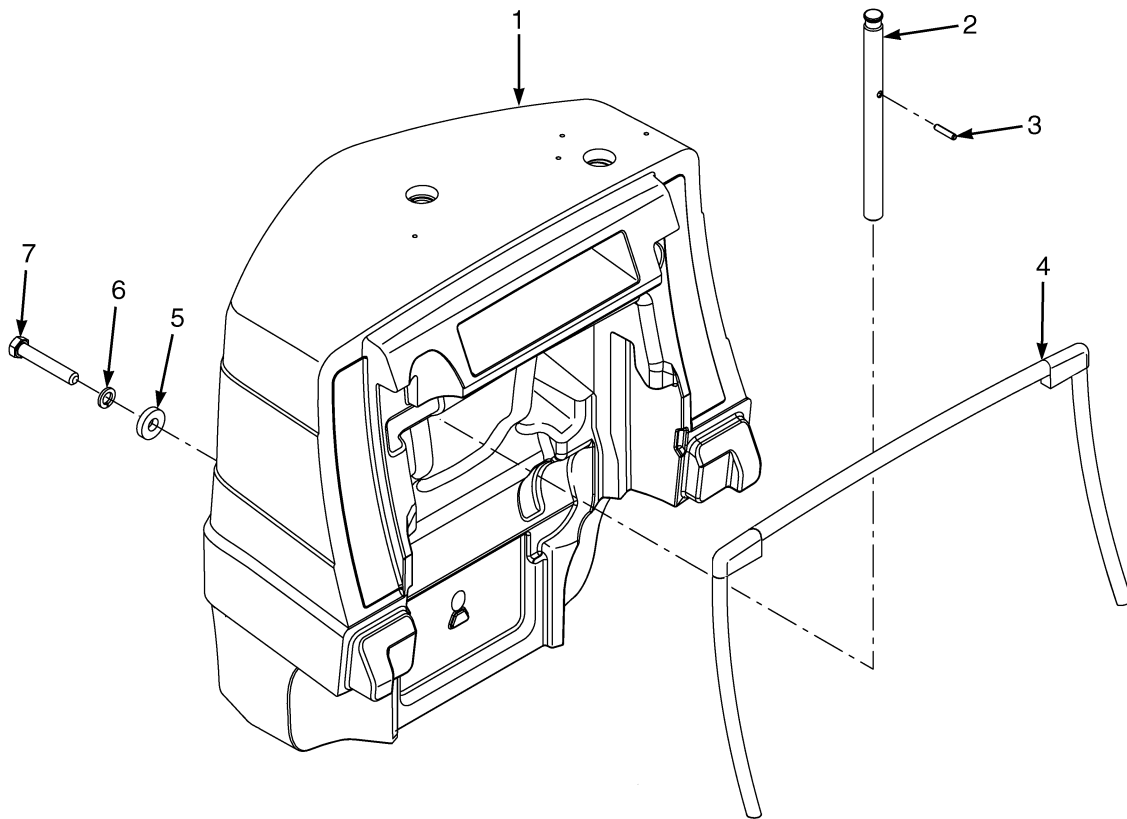

HP120727



Suggest:

For more complete manuals. Please go to the home page.

<https://www.ebooklibonline.com>

If the above button click is invalid. Please download this document first, and then click the above link to download the complete manual.

Thank you so much for reading

ITEM	PART NO.	DESCRIPTION	QTY
1	524173742	Counterweight (GDP/GLP016VX)	1
1	524173743	Counterweight (GDP/GLP018VX)	1
1	524173744	Counterweight (GDP/GLP020FSVX).....	1
2	580036095	Tow Pin	1
3	954513908	Pin	1
4	580051185	Seal	1
5	580002019	Washer	1
6	955400911	Lockwasher	1
7	449001399	Capscrew (101,6 mm)	1

OVERHEAD GUARD

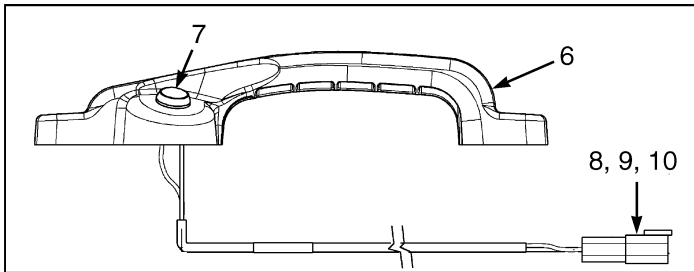
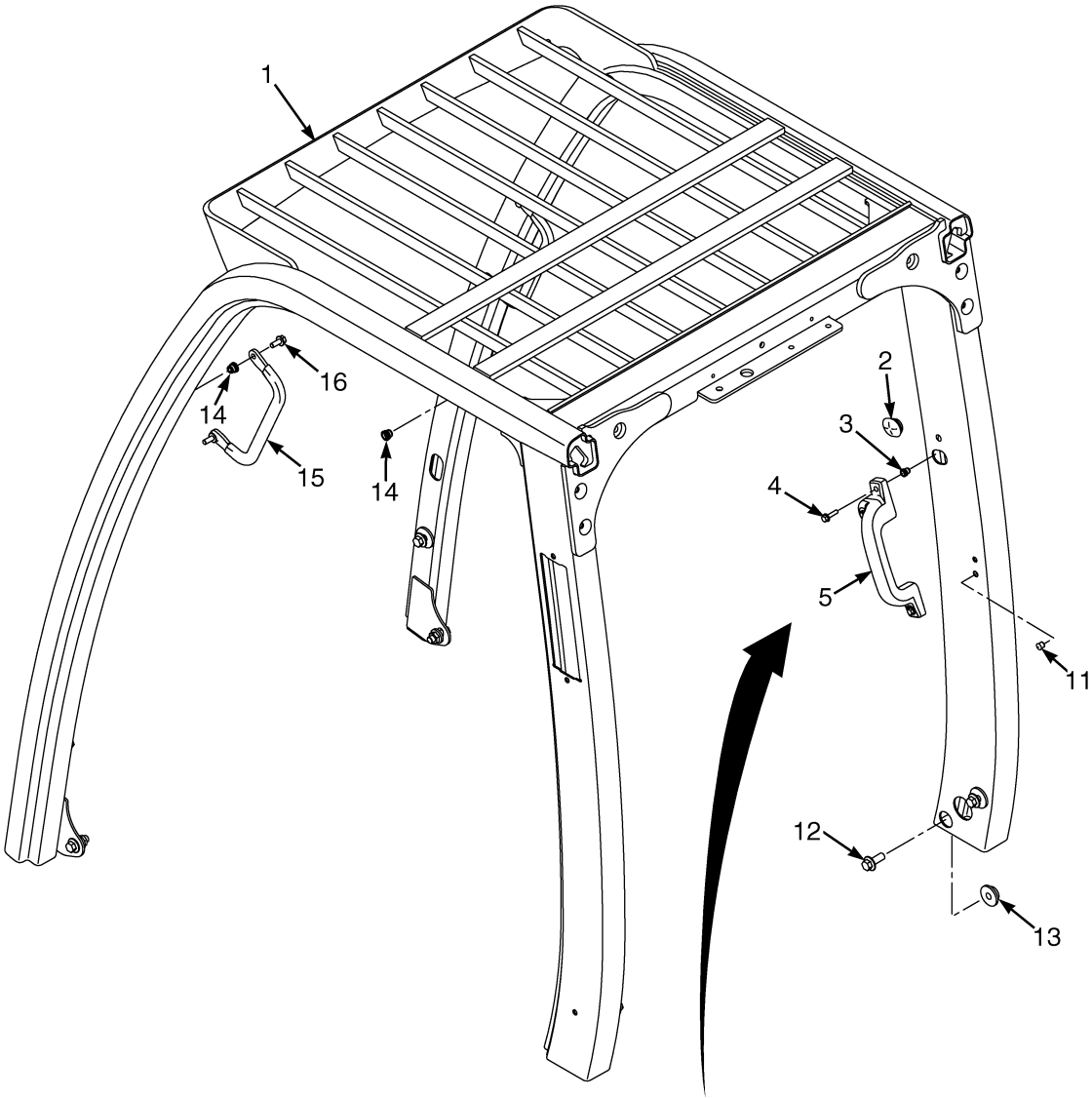

HP120732

<https://www.ebooklibonline.com>

Hello dear friend!

Thank you very much for reading.

Enter the link into your browser.

The full manual is available for immediate download.

<https://www.ebooklibonline.com>