

Parts Manual
Catalogo Parti Ricambi
Manuel des Pièces de Rechange
Ersatzteilkatalog
Manual de Repuestos

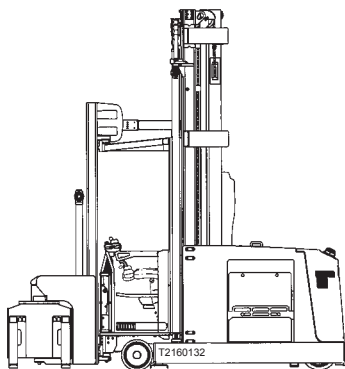

MTC13₈₀-MTC15_{SWB}
MTC15_{MWB}-MTC15_{LWB}
NTA035SB



Specify the following information when ordering spare parts:
 Per ordinare parti di ricambio specificare:
 Pour les commander les pièces détachées veuillez préciser:
 Zum Bestellen von Ersatzteilen bitte folgende Angaben machen:
 Para solicitar los repuestos especificar:

- truck model
- *tipo della macchina*
- type machine
- *Staplertyp*
- tipo de la máquina.

- table N°
- *N° della tavola*
- N° plan
- *Tafel-Nr.*
- N° de la máquina.

- quantity
- *quantità dei particolari richiesti*
- nombre de pièces
- *Erforderliche Stückzahl*
- cantidad de piezas solicitadas.

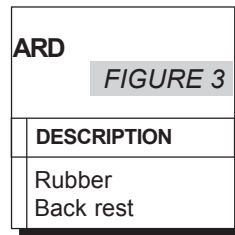
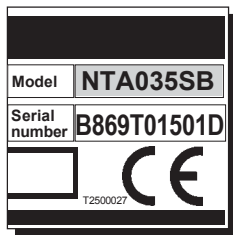

	Q.TY	DESCRI
00	1	Rubber
00	1	Back
55	4	Screw
31	4	Screw
51	8	Elastic
92	4	Washes

NTA035SB B869T01501D FIGURE 3 272315400 4 Screw

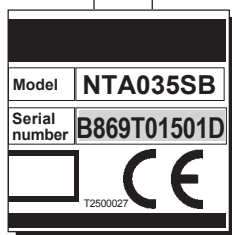

EF.	PART NO.
1	277102000
2	272315400
3	580033000
4	277213400
5	277121300

Q.TY	DESCRIPTION
1	Rubber
1	Back rest
4	Screw
4	Screw
8	Elastic wash

- truck serial number
- *matricola della macchina*
- N° matricule
- *Seriennummer der Maschine*
- matricula de la máquina.

- part number of required component
- *N° di codice del particolare richiesto*
- N° code de la pièce
- *Best. Nr. des erforderlichen Teils*
- N° de código de la pieza solicitada.

- part description
- *demoninazione del particolare richiesto*
- désignation de la pièce
- *Bezeichnung des erforderlichen Teils*
- denominación de la pieza solicitada.

<https://www.ebooklibonline.com>

Hello dear friend!

Thank you very much for reading.

Enter the link into your browser.

The full manual is available for immediate download.

<https://www.ebooklibonline.com>

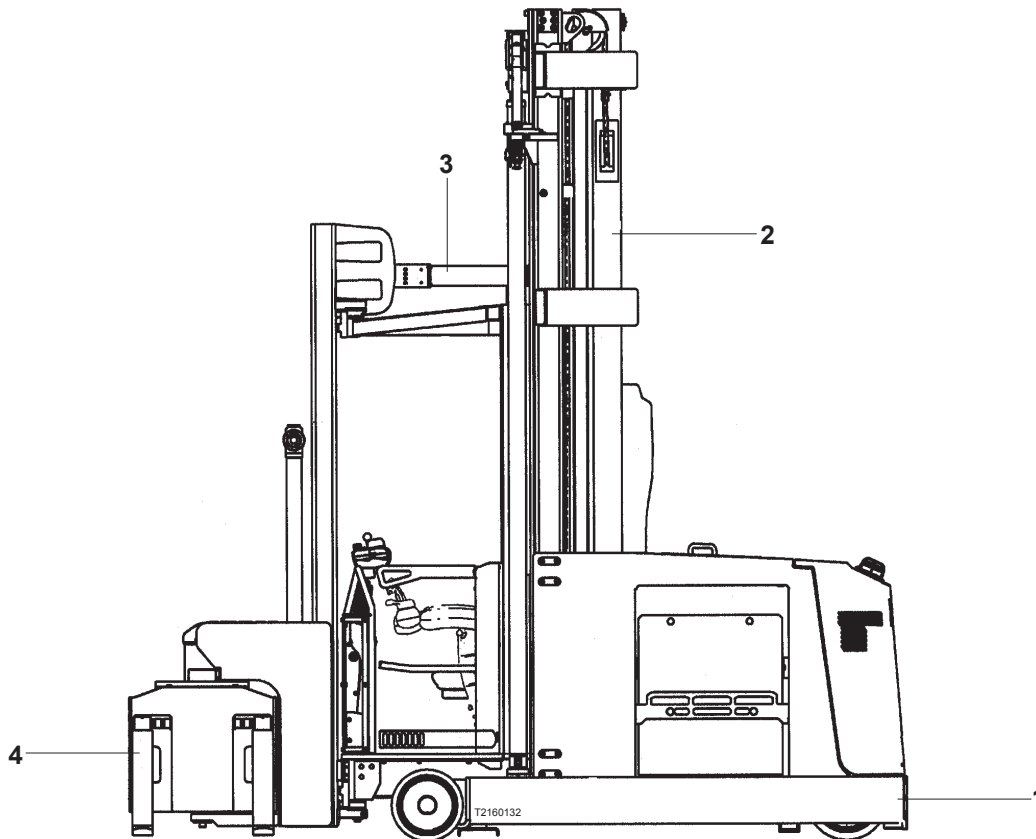

REF.	DIVISION / SEZIONE / SECTION / SEKTION / DIVISIÓN	PAGE NO.
1	FRAME / CARRO / CHÂSSIS / RAHMEN / BASTIDOR	6
2	MAST / MONTANTE / MONTANT / PFOSTEN / MONTANTE	66
3	OPERATOR'S COMPARTMENT / CABINA / CABINE / KABINE / CABINA	118
4	TRILATERAL ATTACHMENT / ATTREZZATURA TRILATERALE / ACCESSOIRE TRILATERAL / ZUBEHÖRTEILE / ACCESSORIO TRILATERAL	174
5	ACCESSORIES / ACCESSORI / ACCESSOIRES / ZUBEHÖR / ACCESSORIOS	202

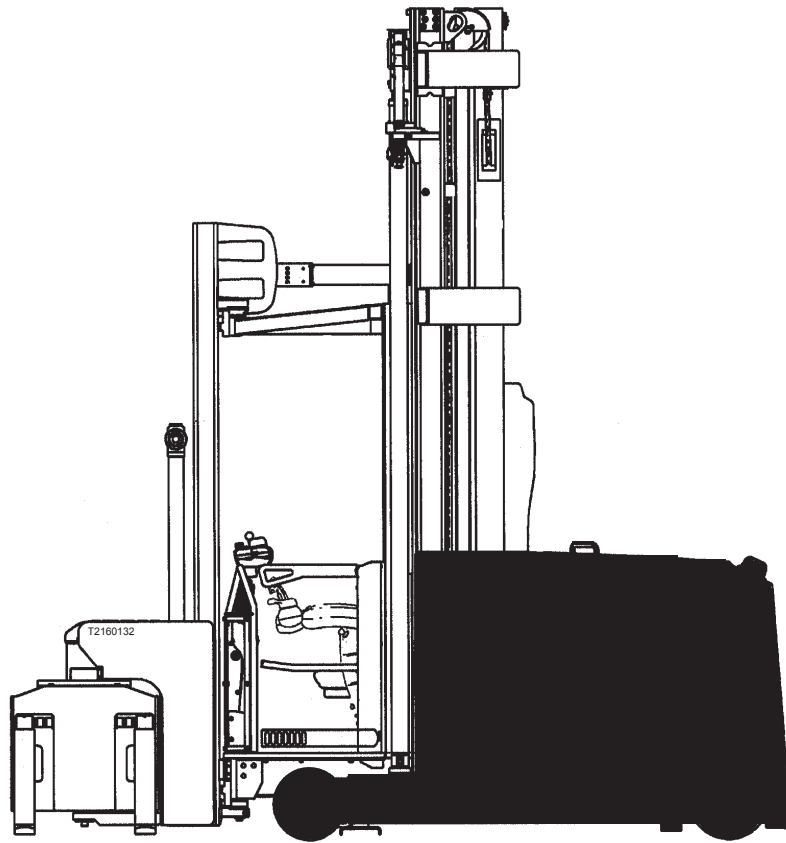

DIVISION 1

DESCRIPTION / DESCRIZIONE / DESIGNATION / BENENNUNG / DENOMINACIONES	PAGE NO.
FRAME / TELAIO / CHÂSSIS / RAHMEN / BASTIDOR FIGURE 1A	8-9
REAR COVERS-BATTERY COVER/ COPERCHI POSTERIORI -COPERCHIO BATTERIA/ COUVERCLE POSTÉRIEUR-COUVERCLE BATTERIE / ABDECKUNG (RÜCKWÄRTS)-BATTERIEABDECKUNG / TAPA POSTERIOR-TAPA DE LA BATERÍA FIGURE 2A	10-11
BATTERY COMPARTMENT / SCOMPARTIMENTO BATTERIA / LOGEMENT DE LA BATTERIE / BATTERIEKASTEN / COMPARTIMIENTO DE LA BATERÍA - MODEL MTC1380 (Frame 2) - FIGURE 3A	12-13
BATTERY COMPARTMENT / SCOMPARTIMENTO BATTERIA / LOGEMENT DE LA BATTERIE / BATTERIEKASTEN / COMPARTIMIENTO DE LA BATERÍA - MODELS MTC15swb-NTA035SB Mast TRI-FORM (Frame 3) - FIGURE 3.1A	14-15
BATTERY COMPARTMENT / SCOMPARTIMENTO BATTERIA / LOGEMENT DE LA BATTERIE / BATTERIEKASTEN / COMPARTIMIENTO DE LA BATERÍA - MODELS MTC15mwb-NTA035SB Mast QUAD-FORM (Frame 4) - FIGURE 3.2A	16-17
BATTERY COMPARTMENT / SCOMPARTIMENTO BATTERIA / LOGEMENT DE LA BATTERIE / BATTERIEKASTEN / COMPARTIMIENTO DE LA BATERÍA - MODELS MTC15Lwb-NTA035SB Mast QUAD-FORM (Frame 5) - FIGURE 3.3A	18-19
SIDE ROLLERS GUIDE / RULLI LATERALI DI GUIDA / ROULEAUX LATÉRAUX GUIDE / SEITLICHE FÜHRUNGSRÖLLE / RODILLOS LATERAL DE GUIA - OPTION - FIGURE 4A	20-21
FRONT ROLLERS GUIDE / RULLI FRONTALI DI GUIDA / ROULEAUX ANTÉRIEUR GUIDE / FRONTAL FÜHRUNGSRÖLLE / RODILLOS FRONTAL DE GUIA - OPTION - FIGURE 5A	22-23
LOAD WHEELS / RUOTE DI CARICO / ROUES DE CHARGEMENT / BESCHICKUNGSRÄDER / RUEDAS DE CARGA FIGURE 6A	24-25
COVER WHEELS / PROTEZIONE RUOTE / PROTECTION ROUES / SCHUTZABDECKUNG RÄDER / PROTECCIÓN RUEDAS - OPTION - FIGURE 7A	26-27
DRIVE UNIT / GRUPPO TRAZIONE - STERZO / GROUPE DE TRACTION - DIRECTION / ZUGAGGREAGAT-EINHEIT MOTOR LENKUNG / GRUPO DE TRACCION - DIRECCIÓN FIGURE 8A	28-29
REDUCTION UNIT / RIDUTTORE / RÉDUCTEUR / GETRIEBEMOTOR / REDUCTOR - GK30 - FIGURE 9A	30-31
REDUCTION UNIT / RIDUTTORE / RÉDUCTEUR / GETRIEBEMOTOR / REDUCTOR - GK40 - FIGURE 9.1A	32-33
DRIVE MOTOR / MOTORE DI TRAZIONE / MOTEUR DE TRACTION / ZUGMOTOR / MOTOR DE TRACCION FIGURE 10A	34-35
ELECTROMAGNETIC BRAKE / FRENO ELETTROMAGNETICO / FREIN ÉLECTROMAGNETIQUE / ELEKTROMATISCHE BREMSE / FRENO ELECTROMAGNÉTICO FIGURE 11A	36-37
STEERING MOTOR / MOTORIDUTTORE STERZO / MOTOREDUCTEUR DIRECTION / MOTORVERMINDERER FÜR ELEKTRISCHE LENKUNG / MOTOREDUCTOR DIRECCION - MODELS WITH GK30 - FIGURE 12A	38-39
STEERING MOTOR / MOTORIDUTTORE STERZO / MOTOREDUCTEUR DIRECTION / MOTORVERMINDERER FÜR ELEKTRISCHE LENKUNG / MOTOREDUCTOR DIRECCION - MODELS WITH GK40 - FIGURE 12.1A	40-41
HYDRAULIC GROUP / GRUPPO IDRAULICO / INSTALLATION HYDRAULICA / HYDRAULIKANLAGE / INSTALACION HIDRAULICA FIGURE 13A	42-45
LIFT MOTOR AND PUMP / MOTORE SOLLEVAMENTO E POMPA / MOTOPOMPE SOULEVEMENT / MOTORPUMPE ZUR ANAEBUNG / MOTOBOMBA ELEVACIÓN FIGURE 14A	46-47
MANIFOLD MAIN / BLOCCO PRINCIPALE COMANDO CABINA / SOUPAPE PRINCIPAL / HAUPTVENTIL / VÁLVULA PRINCIPAL FIGURE 15A	48-49
HIGH PERFORMANCE LOWERING VALVE / VALVOLA DISCESA VELOCE CABINA / SOUPAPE DESCENTE RAPIDE CABINE / VENTIL SENKEN SCHNELL KABINE / VÁLVULA BAJADA RÁPIDA CABINA - OPTION - FIGURE 15.1A	50-51
MANIFOLD STABILISERS / BLOCCO COMANDO STABILIZZATORI / SOUPAPE STABILISATEURS / STABILISATORENVENTIL / VÁLVULA ESTABILIZADORES - OPTION - FIGURE 16A	52-53
ELECTRIC PANEL / QUADRO ELETTRICO / PANNEAU ÉLECTRIQUE / ELEKTRISCHE SCHALTTAFEL / PANEL ELECTRICO FIGURE 17A	54-55
ELECTRICAL ARRANGEMENT (POWER CABLES) / IMPIANTO ELETTRICO (CAVI DI POTENZA) / INSTALLATION ÉLECTRIQUE (CABLES DE PUISSANCE) / ELEKTRISCHE (LEISTUNGKABEL) / INSTALACION ELECTRICA (CABLE DE POTENCIA) FIGURE 18A	56-57
ELECTRICAL ARRANGEMENT / IMPIANTO ELETTRICO / INSTALLATION ÉLECTRIQUE / ELEKTRISCHE / INSTALACION ELECTRICA FIGURE 19A	58-63
LABELS / TARGHETTE E ADESIVI / AUTOCOLLANTS DE SIGNALISATION / SELBSTKLEBESCHILDER / TARJETAS ADHESIVAS FIGURE 20A	64-65

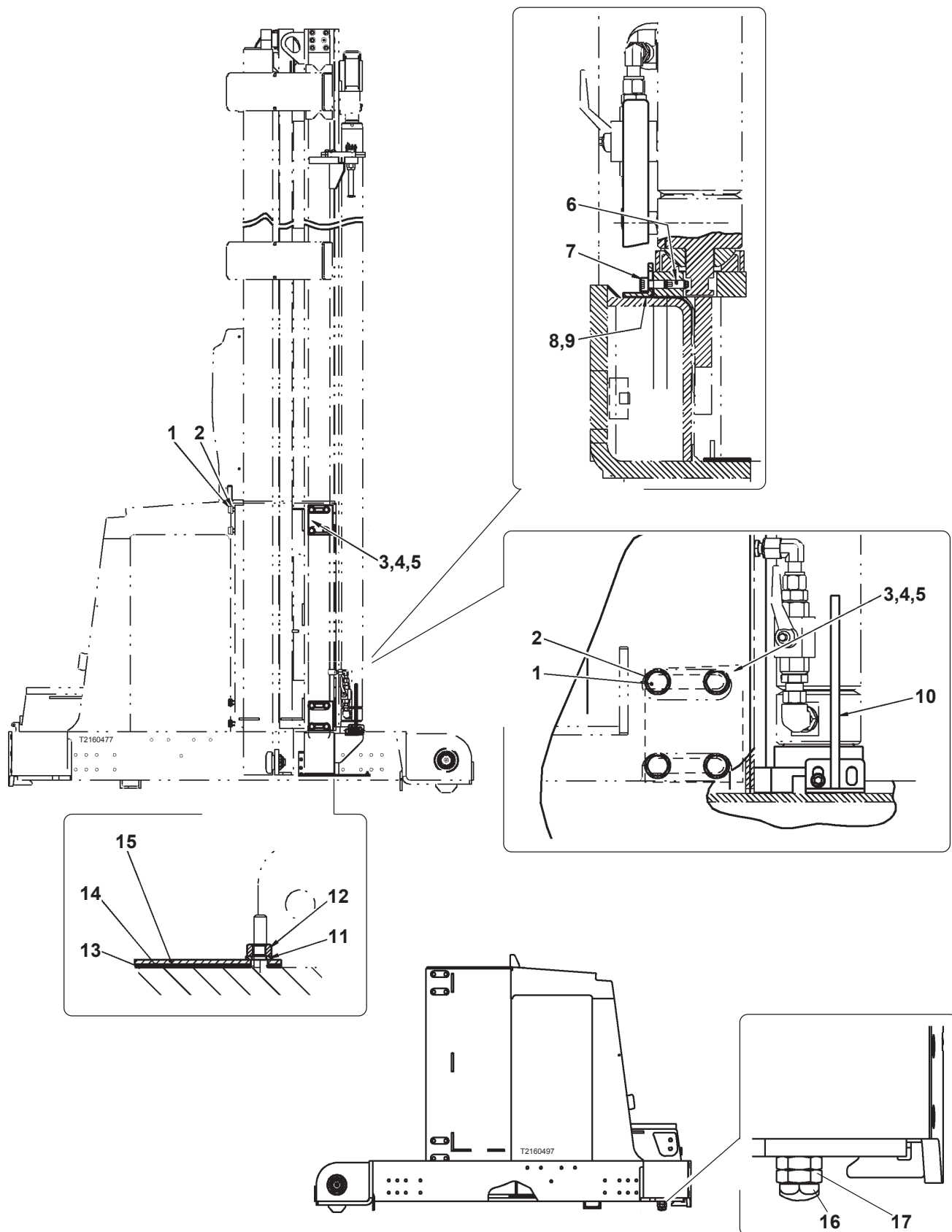

REF.	PART NO.	Q.TY	DESCRIPTION	DESCRIZIONE	DESIGNATION	BENENNUNG	DENOMINACIONES	PART DETAILS
1	311323021	24	Screw	Vite	Vis	Schraube	Tomillo	For models with TRI FORM mast
1	311323021	28	Screw	Vite	Vis	Schraube	Tomillo	For models with QUAD FORM mast
2	449021019	24	Washer	Rondella	Rondelle	Unterlegscheibe	Arandela	For models with TRI FORM mast
2	449021019	28	Washer	Rondella	Rondelle	Unterlegscheibe	Arandela	For models with QUAD FORM mast
3	580071527	AR	Shim	Spessore	Entretoise	Distanzstück	Espaciador	0,5 mm
4	580071526	AR	Shim	Spessore	Entretoise	Distanzstück	Espaciador	1 mm
5	580071525	AR	Shim	Spessore	Entretoise	Distanzstück	Espaciador	2 mm
6	580010264	2	Screw	Vite	Vis	Schraube	Tomillo	
7	580026611	2	Screw	Vite	Vis	Schraube	Tomillo	
8	580058630	2	Plate	Piatto	Plaque	Teller	Plato	0,5 mm
9	580058631	2	Plate	Piatto	Plaque	Teller	Plato	1 mm
10	580069468	2	Cylinder rotation lock	Piatto	Plaque	Teller	Plato	
11	449021003	4	Washer	Rondella	Rondelle	Unterlegscheibe	Arandela	
12	504574259	4	Nut	Dado	Écrou	Mutter	Tuerca	
13	580071528	AR	Shim	Spessore	Entretoise	Distanzstück	Espaciador	0,5 mm
14	580071529	AR	Shim	Spessore	Entretoise	Distanzstück	Espaciador	1 mm
15	580071530	AR	Shim	Spessore	Entretoise	Distanzstück	Espaciador	2 mm
16	272506700	2	Screw	Vite	Vis	Schraube	Tomillo	
17	937701930	4	Nut	Dado	Écrou	Mutter	Tuerca	

From serial N° / *Da matr. /*
Du matr. / *Ab. seriennummer /*
Desde la matr. :

Until serial N° / *Fino a matr. /*
Jusq' matr. / *Bis zur serien-Nr. /*
Hasta la matr. :

With the exception of /
Ad esclusione di / À l'exclusion de /
Mit ausnahme von / Excepto :

Including / *Compreso / Avec /*
Einschließlich / Con :

B869T01501D

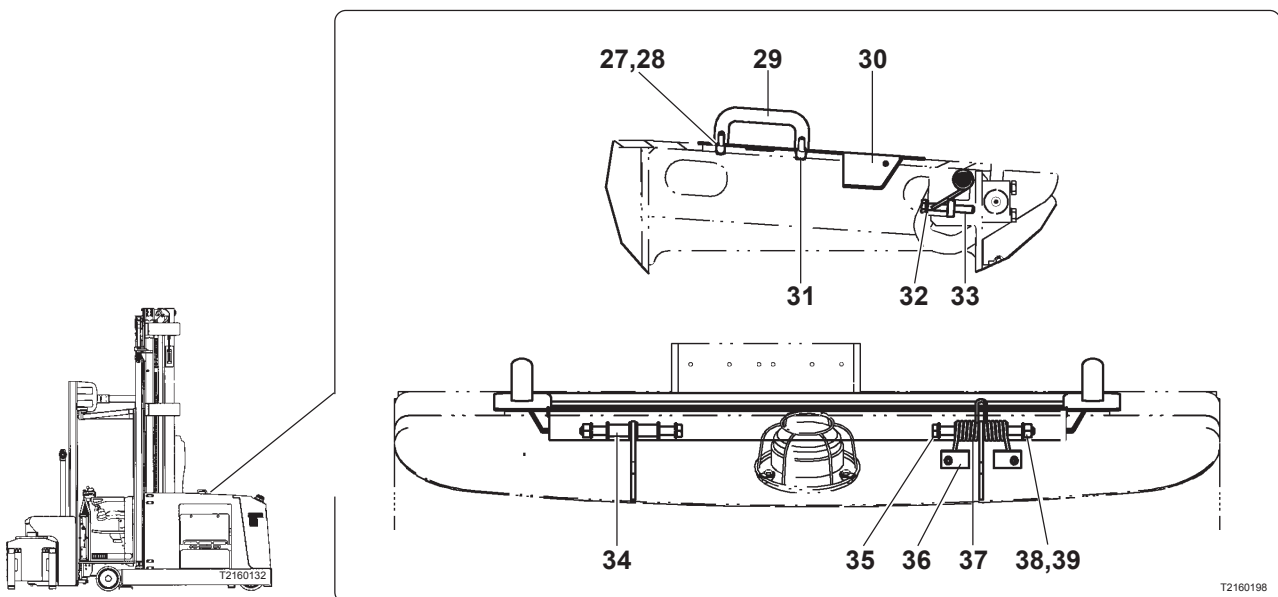
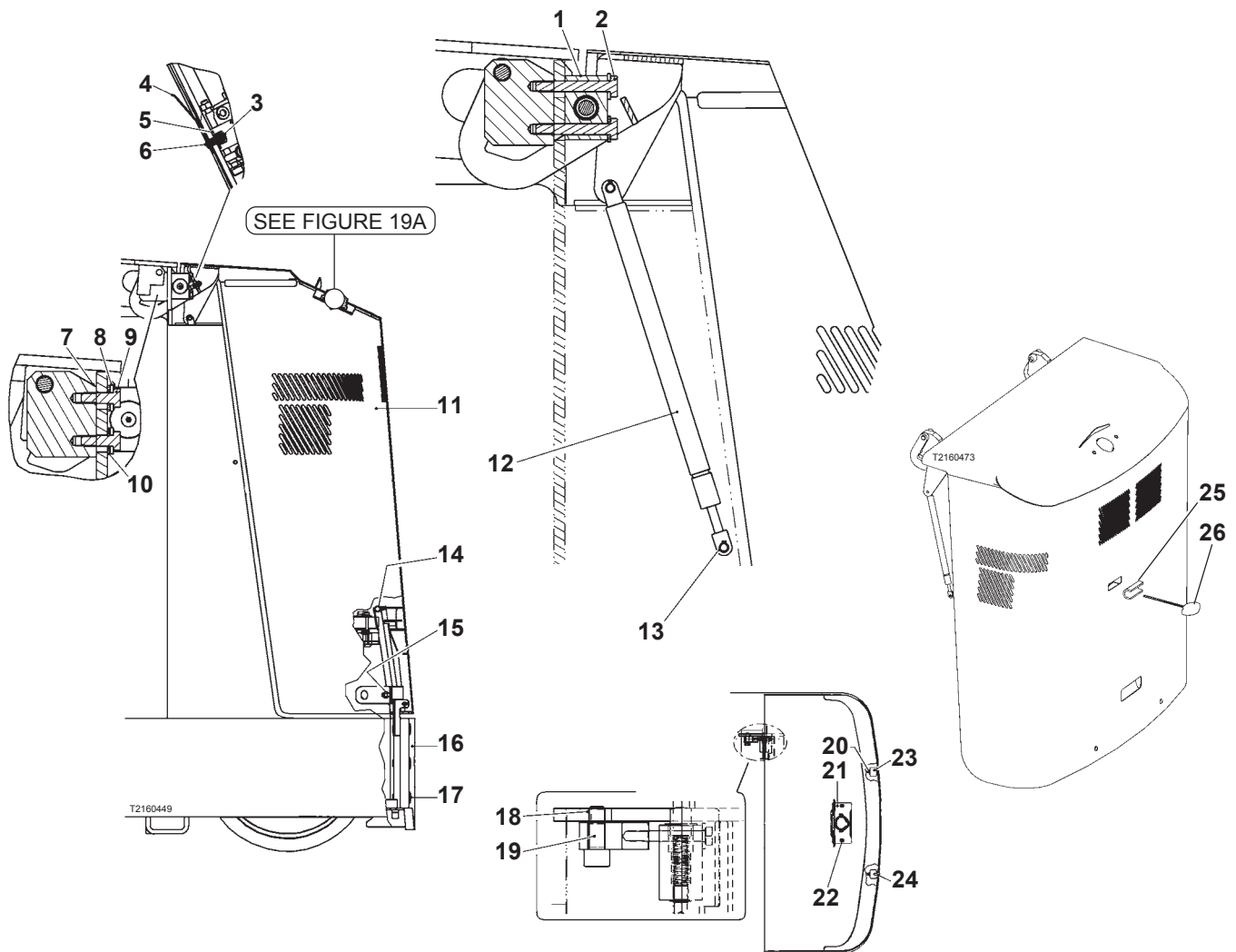

REAR COVERS - BATTERY COVER
COPERCHI POSTERIORI - COPERCHIO BATTERIA
COUVERCLE POSTÉRIEUR - COUVERCLE BATTERIE
ABDECKUNG (RÜCKWÄRTS) - BATTERIEABDECKUNG
TAPA POSTERIOR - TAPA DE LA BATERÍA

FIGURE 2A

REF.	PART NO.	Q.TY	DESCRIPTION	DESCRIZIONE	DESIGNATION	BENENNUNG	DENOMINACIONES	PART DETAILS
1	580055364	1	Safety block	Blocco di sicurezza	Bloc de sécurité	Block	Bloque de seguridad	
2	449001233	2	Screw	Vite	Vis	Schraube	Tornillo	
3	449015135	1	Nut	Dado	Écrou	Mutter	Tuerca	
4	272347600	1	Plate	Piatto	Plaque	Teller	Plato	
5	580017101	1	Washer	Rondella	Rondelle	Unterlegscheibe	Arandela	
6	518791613	1	Screw	Vite	Vis	Schraube	Tornillo	
7	580051530	2	Cover support	Supporto coperchio	Support couvercle	Lager	Soporte tapa	
8	504071785	4	Washer	Rondella	Rondelle	Unterlegscheibe	Arandela	
9	449001302	2	Screw	Vite	Vis	Schraube	Tornillo	
10	449021010	2	Washer	Rondella	Rondelle	Unterlegscheibe	Arandela	
11	524230452	1	Cover	Coperchio	Couvercle	Batterieabdeckung	Tapa de la batería	
12	580058256	2	Gas spring	Asta gas	Tige gaz	Gasschiene	Varilla del gas	
13	15914400	4	Snap ring	Seeger	Arretoi	Seeger	Anillo Seeger	
14	580058376	1	Gasket	Guamizione	Joint	Dichtung	Junta	
15	449015098	2	Nut	Dado	Écrou	Mutter	Tuerca	
16	524229865	1	Plate	Piastra	Plaque	Platte	Plancha	
17	272022800	6	Screw	Vite	Vis	Schraube	Tornillo	
18	580051582	2	Bushing	Boccola	Douille	Buchse	Casquillo	
19	580051531	2	Cover screw	Vite	Vis	Schraube	Tornillo	
20	449021001	4	Washer	Rondella	Rondelle	Unterlegscheibe	Arandela	
21	580068231	1	Bent plate	Piastra	Plaque	Platte	Plancha	
22	272342200	2	Nut	Dado	Écrou	Mutter	Tuerca	
23	277533300	2	Vibration damping	Antivibrante	Antivibrant	Schwingungsdamp	Antivibrador	
24	580032377	2	Screw	Vite	Vis	Schraube	Tornillo	
25	580070744	1	Rubber	Gomma	Caoutchouc	Gummi	Goma	
26	580070743	1	Wrench	Chiave	Clef	Schlüssel	llave	
27	449022016	4	Washer	Rondella	Rondelle	Unterlegscheibe	Arandela	
28	449021001	4	Washer	Rondella	Rondelle	Unterlegscheibe	Arandela	
29	273034900	2	Handle	Manopola	Pomme	Griff	Perilla	
30	580058258	1	Cover	Coperchio	Couvercle	Batterieabdeckung	Tapa de la batería	MTC 13(80)-MTC 15SWB-N TA035SB MAST TRI-FORM
30	580058259	1	Cover	Coperchio	Couvercle	Batterieabdeckung	Tapa de la batería	MTC 15MWB-MTC 15LWB-N TA035SB MAST QUAD-FORM
31	580022964	4	Screw	Vite	Vis	Schraube	Tornillo	
32	449022013	2	Washer	Rondella	Rondelle	Unterlegscheibe	Arandela	
33	931014913	2	Screw	Vite	Vis	Schraube	Tornillo	MTC 13(80)-MTC 15SWB-N TA035SB MAST TRI-FORM
33	931014913	4	Screw	Vite	Vis	Schraube	Tornillo	MTC 15MWB-MTC 15LWB-N TA035SB MAST QUAD-FORM
34	504064739	4	Spacer	Distanziale	Entretoise	Abstandhalter	Separador	
35	931015920	2	Screw	Vite	Vis	Schraube	Tornillo	
36	580057321	1	Plate	Piastra	Plaque	Platte	Plancha	MTC 13(80)-MTC 15SWB-N TA035SB MAST TRI-FORM
36	580057321	2	Plate	Piastra	Plaque	Platte	Plancha	MTC 15MWB-MTC 15LWB-N TA035SB MAST QUAD-FORM
37	580057322	1	Spring torsion	Molla	Ressort	Feder	Resorte	
38	449022017	4	Washer	Rondella	Rondelle	Unterlegscheibe	Arandela	
39	580033885	2	Nut	Dado	Écrou	Mutter	Tuerca	

From serial N° / Da matr. /
 Du matr. / Ab. seriennummer /
 Desde la matr. :

Until serial N° / Fino a matr. /
 Jusq' matr. / Bis zur serien-Nr. /
 Hasta la matr. :

With the exception of /
 Ad esclusione di / À l'exclusion de /
 Mit ausnahme von / Excepto :

Including / Compreso / Avec /
 Einschließlich / Con :

B869T01501D

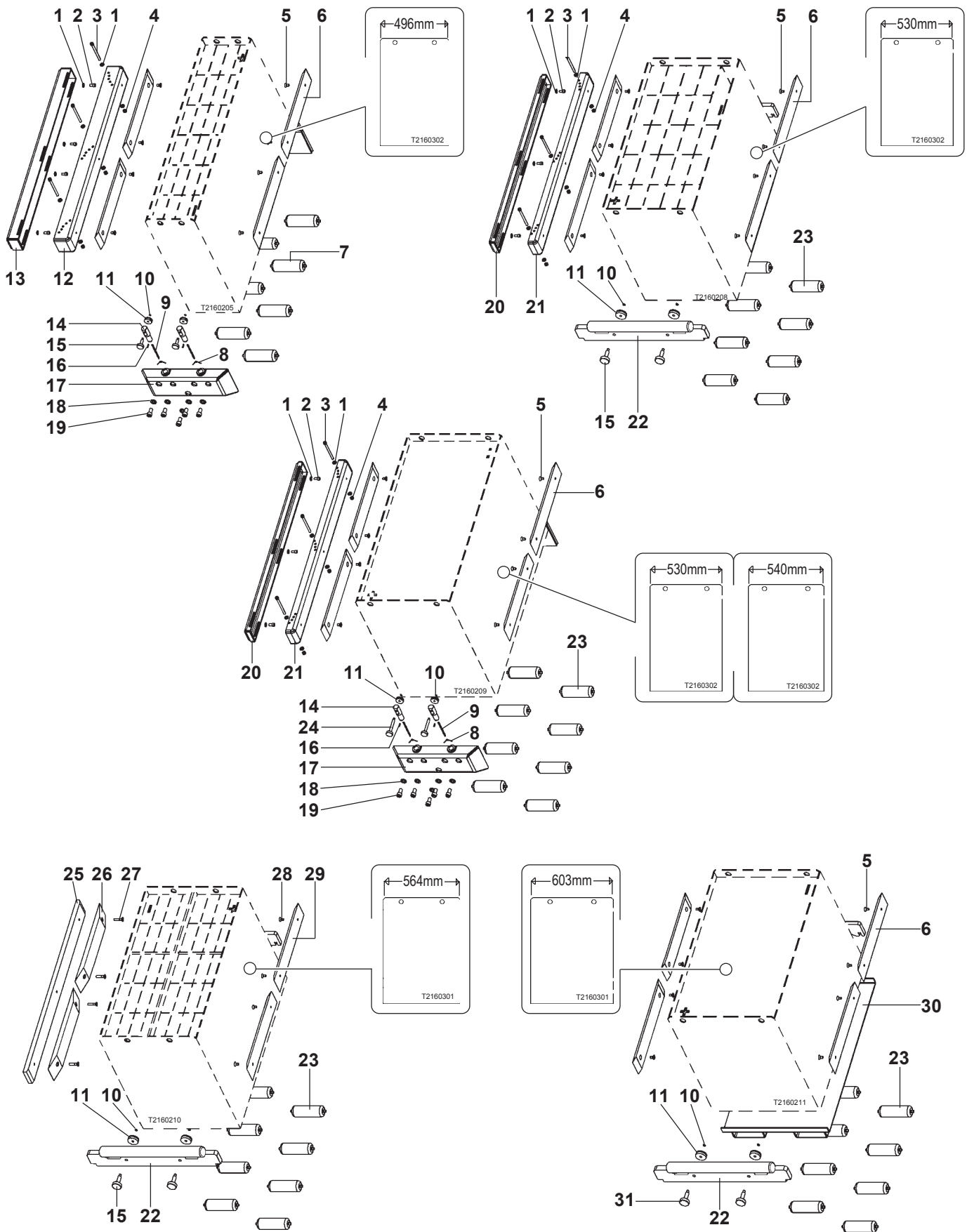

REF.	PART NO.	Q.TY	DESCRIPTION	DESCRIZIONE	DESIGNATION	BENENNUNG	DENOMINACIONES
1	449021006	10	Washer	Rondella	Rondelle	Unterlegscheibe	Arandela
2	580026611	4	Screw	Vite	Vis	Schraube	Tornillo
3	580063977	3	Screw	Vite	Vis	Schraube	Tornillo
4	449015036	3	Nut	Dado	Écrou	Mutter	Tuerca
5	580008442	8	Screw	Vite	Vis	Schraube	Tornillo
6	580042659	4	Slide	Guida	Guide	Führungsschieber	Guía
7	273070600	7	Roller	Rullo	Galet	Walze	Perilla
8	277258000	4	Spring	Molla	Ressort	Feder	Resorte
9	277257900	4	Chain	Catena	Chaîne	Kette	Caden
10	273087700	4	Snap ring	Seeger	Arretoi	Seeger	Anillo seeger
11	273101900	4	Battery block washer	Rondella	Rondelle	Unterlegscheibe	Arandela
12	580042657	1	Slide	Guida	Guide	Führungsschieber	Guía
13	580042656	1	Slide support	Supporto	Support	Lager	Soporte
14	277257800	4	Support	Supporto	Support	Lager	Soporte
15	273084100	4	Battery block screw	Vite	Vis	Schraube	Tornillo
16	023021100	4	Pin	Perno	Pivot	Drehkupplungszapfen	Perno
17	580042654	2	Battery block support	Supporto	Support	Lager	Soporte
18	449021019	10	Washer	Rondella	Rondelle	Unterlegscheibe	Arandela
19	932205903	10	Screw	Vite	Vis	Schraube	Tornillo
20	580042655	1	Slide support	Supporto	Support	Lager	Soporte
21	580042658	1	Slide	Guida	Guide	Führungsschieber	Guía
22	580070068	2	Battery stop	Fermo batteria	Fixation batterie	Batteriestillstand	Sujetador bateria
23	273070600	8	Roller	Rullo	Galet	Walze	Perilla
24	580063978	4	Battery block screw	Vite	Vis	Schraube	Tornillo
25	580042663	1	Thickness	Spessore	Entretoise	Distanzstück	Espaciador
26	580042660	2	Slide	Guida	Guide	Führungsschieber	Guía
27	580009799	4	Screw	Vite	Vis	Schraube	Tornillo
28	580008442	4	Screw	Vite	Vis	Schraube	Tornillo
29	580042659	2	Slide	Guida	Guide	Führungsschieber	Guía
30	580041626	1	Battery tray	Supporto batteria	Support batterie	Batterielager	Soporte batería
31	580063979	4	Battery block screw	Vite	Vis	Schraube	Tornillo

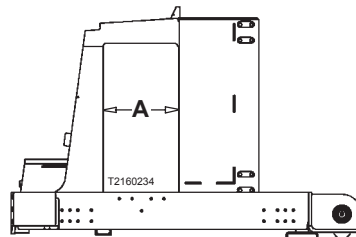

Frame 2 - A=635 mm
 Frame 3 - A=755 mm
 Frame 4 - A=885 mm
 Frame 5 - A=1080 mm

25.4 mm = 1"

From serial N° / Da matr. /
 Du matr. / Ab. seriennummer /
 Desde la matr. :

Until serial N° / Fino a matr. /
 Jusq' matr. / Bis zur serien-Nr. /
 Hasta la matr. :

With the exception of /
 Ad esclusione di / À l'exclusion de /
 Mit ausnahme von / Excepto :

Including / Compreso / Avec /
 Einschließlich / Con :

B869T01501D

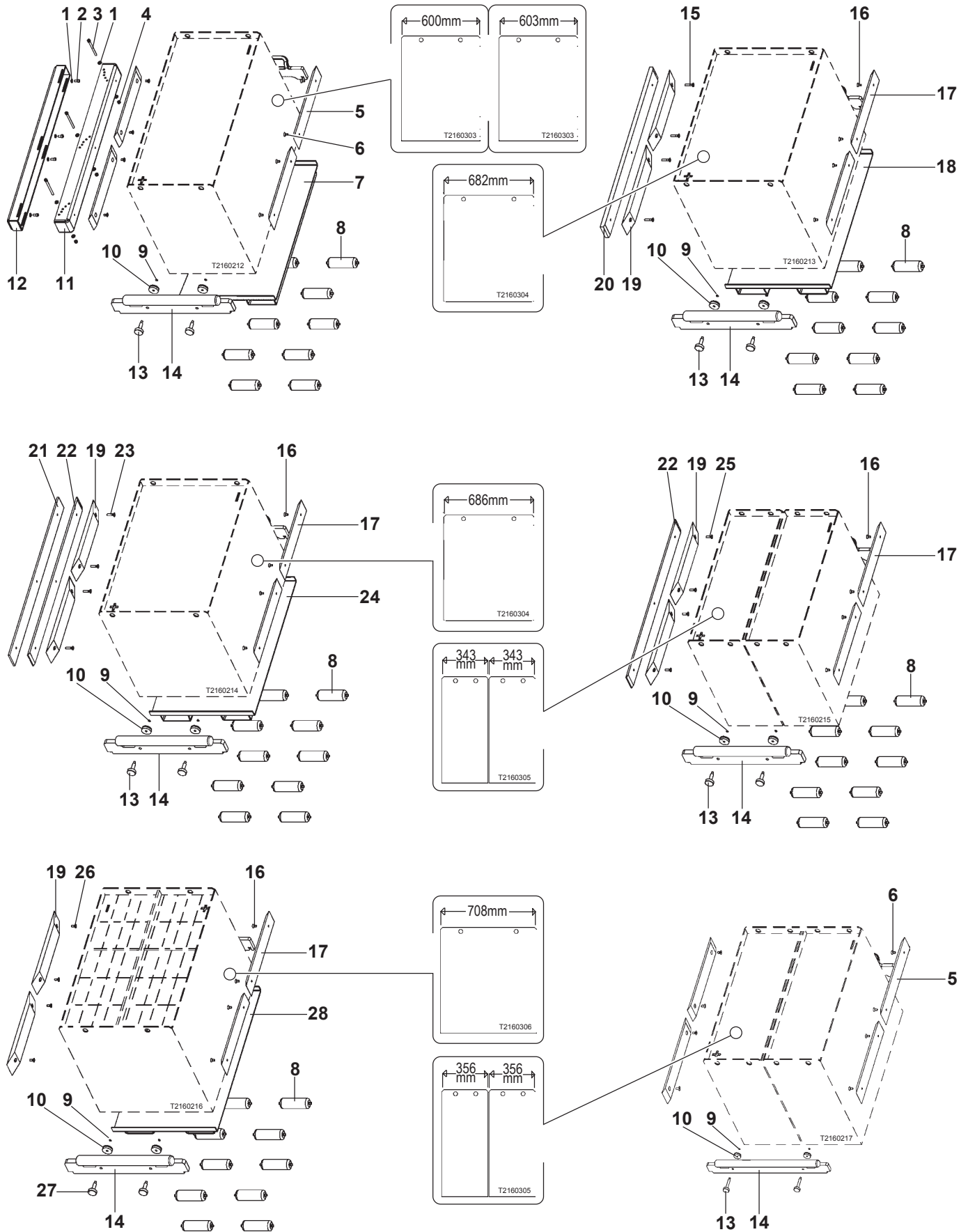



Suggest:

For more complete manuals. Please go to the home page.

<https://www.ebooklibonline.com>

If the above button click is invalid. Please download this document first, and then click the above link to download the complete manual.

Thank you so much for reading

REF.	PART NO.	Q.TY	DESCRIPTION	DESCRIZIONE	DESIGNATION	BENENNUNG	DENOMINACIONES
1	449021006	10	Washer	Rondella	Rondelle	Unterlegscheibe	Arandela
2	580026611	4	Screw	Vite	Vis	Schraube	Tornillo
3	580063977	3	Screw	Vite	Vis	Schraube	Tornillo
4	449015036	3	Nut	Dado	Écrou	Mutter	Tuerca
5	580042659	4	Slide	Guida	Guide	Führungsschieber	Guía
6	580008442	8	Screw	Vite	Vis	Schraube	Tornillo
7	580041625	1	Battery tray	Supporto batteria	Support batterie	Batterielager	Soporte batería
8	273070600	10	Roller	Rullo	Galet	Walze	Perilla
9	273087700	4	Snap ring	Seeger	Arretoi	Seeger	Anillo seeger
10	273101900	4	Battery block washer	Rondella	Rondelle	Unterlegscheibe	Arandela
11	580042657	1	Slide	Guida	Guide	Führungsschieber	Guía
12	580042656	1	Slide support	Supporto	Support	Lager	Soporte
13	580063979	4	Battery block screw	Vite	Vis	Schraube	Tornillo
14	580070070	2	Battery stop	Fermo batteria	Fixation batterie	Batteriestillstand	Sujetador batería
15	580009799	4	Screw	Vite	Vis	Schraube	Tornillo
16	580008442	4	Screw	Vite	Vis	Schraube	Tornillo
17	580042659	2	Slide	Guida	Guide	Führungsschieber	Guía
18	580041624	1	Battery tray	Supporto batteria	Support batterie	Batterielager	Soporte batería
19	580042660	2	Slide	Guida	Guide	Führungsschieber	Guía
20	580042663	1	Thickness	Spessore	Entretoise	Distanzstück	Espaciador
21	580042661	1	Thickness	Spessore	Entretoise	Distanzstück	Espaciador
22	580042662	1	Thickness	Spessore	Entretoise	Distanzstück	Espaciador
23	580023194	4	Screw	Vite	Vis	Schraube	Tornillo
24	580041623	1	Battery tray	Supporto batteria	Support batterie	Batterielager	Soporte batería
25	520045581	4	Screw	Vite	Vis	Schraube	Tornillo
26	273084100	4	Battery block screw	Vite	Vis	Schraube	Tornillo
27	900010217	4	Screw	Vite	Vis	Schraube	Tornillo
28	580041622	1	Battery tray	Supporto batteria	Support batterie	Batterielager	Soporte batería

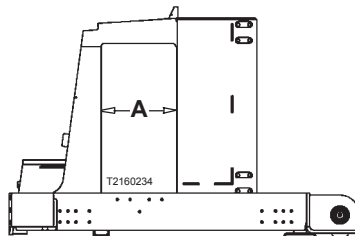

Frame 2 - **A**=635 mm
 Frame 3 - **A**=755 mm
 Frame 4 - **A**=885 mm
 Frame 5 - **A**=1080 mm

25.4 mm = 1"

From serial N° / *Da matr.* /
 Du matr. / *Ab. seriennummer* /
 Desde la matr. :

Until serial N° / *Fino a matr.* /
 Jusq' matr. / *Bis zur serien-Nr.* /
 Hasta la matr. :

With the exception of /
Ad esclusione di / À l'exclusion de /
Mit ausnahme von / Excepto :

Including / *Compreso* / *Avec* /
Einschließlich / Con :

B869T01501D

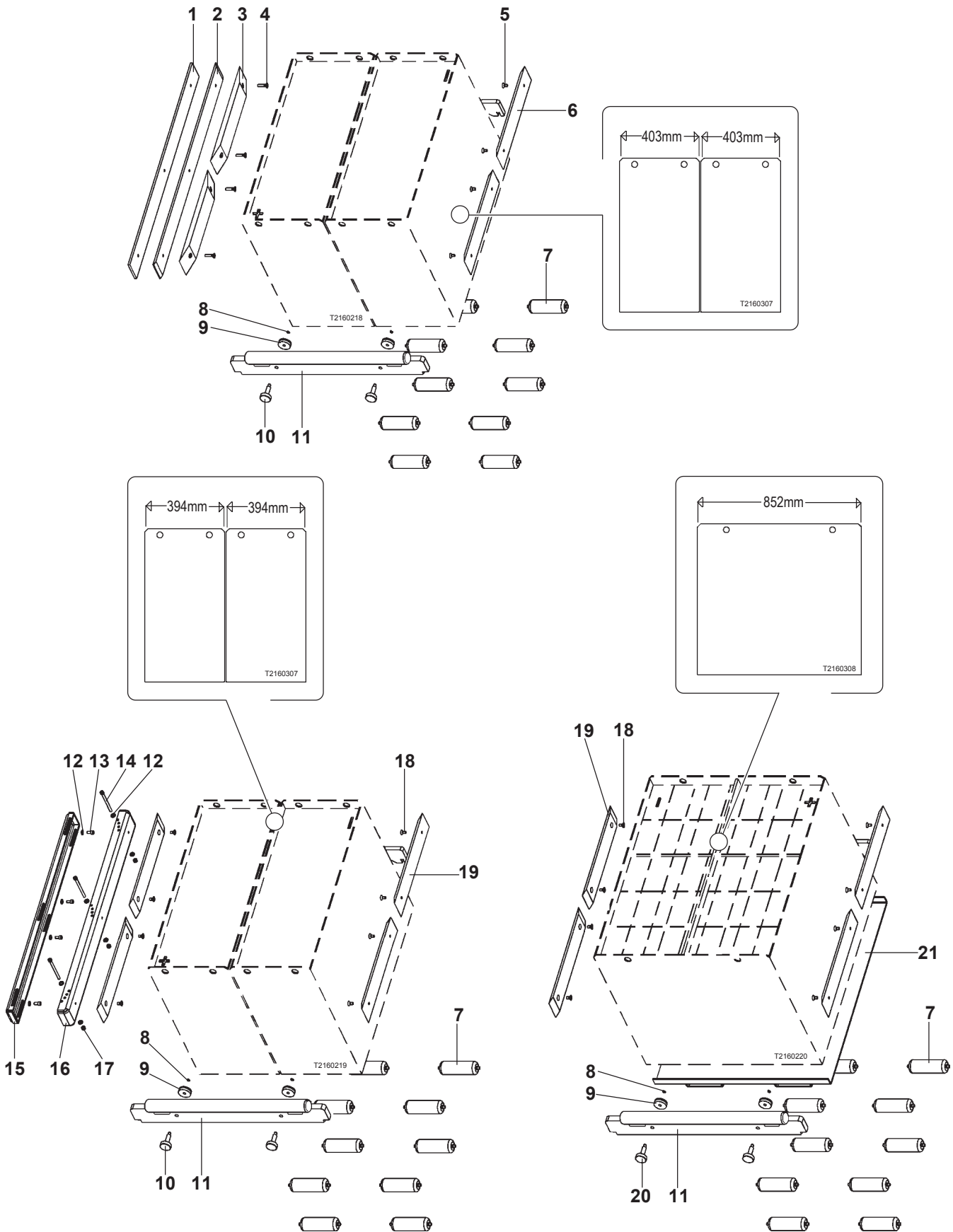

<https://www.ebooklibonline.com>

Hello dear friend!

Thank you very much for reading.

Enter the link into your browser.

The full manual is available for immediate download.

<https://www.ebooklibonline.com>