

Parts Manual
Catalogo Parti Ricambi
Manuel des Pièces de Rechange
Ersatzteilkatalog
Manual de Repuestos

CE

T2500027

MP20-30S

Yale 
T2500054

Part FIGURE index / <i>Indice delle tavole</i> / Index des tables / <i>Tafelverzeichnis</i> / Indice de tablas	page 2-3
Legend of symbols used in this handbook / <i>Legenda simbologia impiegata sul catalogo</i> / Legende symbolique utilisée sur catalogue / <i>Legende der Katalogsymbole</i> / Leyenda simbología empleada en el catálogo	page 4
How to use the handbook / <i>Uso del catalogo</i> / Utilisation du catalogue / <i>Nachschlagen des Katalogs</i> / Uso del catálogo	page 5
Fork carriage / <i>Spalliera</i> / Fourche / <i>Gabe</i> / Horquilla (part Fig. 1)	page 6-7
Frame / <i>Telaio</i> / Chassis / <i>Rahmen</i> / Bastidor (Fig.2)	page 8-9
Support and wheel / <i>Supporto e ruota</i> / Support et attelage / <i>Lagern und räder</i> / Soporte y rueda (part Fig. 3)	page 10-11
Hydraulic system / <i>Impianto idraulico</i> / Installation hydraulique / <i>Hydraulikanlage</i> / Instalacion hidraulica (part Fig.4)	page 12-13
Lifting cylinder / <i>Cilindro di sollevamento</i> / Cilindre de soulevement / <i>Hubzylinder</i> / Cilindro de elevación (part Fig.5)	page 14-15
Electronic system / <i>Impianto elettronico</i> / Installation électronique / <i>Elektronik</i> / Instalacion electronica (Fig.6)	page 16-17
Steering group / <i>Gruppo sterzo</i> / Groupe direction / <i>Steuergruppr</i> / Grupo volante (Fig. 7)	page 18-19
Brake system / <i>Impianto freni</i> / Installation freins / <i>Bremsanlage</i> / Equipo de frenos (Fig. 8)	page 20-21
Traction unit / <i>Gruppo trazione</i> / Groupe de traction / <i>Zugaggregat</i> / Grupo de traccion (part Fig. 9)	page 22-23
Traction motor / <i>Motore trazione</i> / Moteur de traction / <i>Zugmotor</i> / Motor de traccion (part Fig. 10)	page 24-25
Labels / <i>Adesivi</i> / Autocollants de signalisation / <i>Selbstklebeschilder</i> / Tarjetas adhesivas (part Fig.11)	page 26-27
Fixed battery truck / <i>Carrellino estrazione batteria fisso</i> / Chariot pour extraction batterie fixe / <i>Schlitten zur batterieausnahme standfest</i> / Carro extracción batería fijo (part Fig. 12)	page 28-29
Double battery truck (option) / <i>Carrellino estrazione batteria doppio (optional)</i> / Chariot pour extraction batterie double (optionnel) / <i>Schlitten zur batterieausnahme (wahlfrei)</i> / Carro extracción batería doble (opcional)(part Fig.13)	page 30-31

Hydraulic diagram / <i>Schema idraulico</i> / Schéma hydraulique / <i>Hydraulikschaltplan</i> / Esquema oleodinámico (part Fig. 14)	page 32-33
Power cables diagram / <i>Schema collegamenti cavi di potenza</i> / Diagramme liaison cable de puissance / <i>Elektrischeanlageplan</i> / Esquema conexion cable de potencia (Fig.15)	page 34-35
Sheath diagram / <i>Schema collegamenti guaine</i> / Diagramme liaison gaines / <i>Mantelanlageplan</i> / Esquema conexion vaina (Fig.16)	page 36-37
Electronic diagram / <i>Schema elettronico</i> / Diagramme électronique / <i>Elektronikschaltplan</i> / Esquema electrónico (Fig.17)	page 38-39
Console adapter / <i>Adattatore per consolle</i> / Adaptateur pour console / <i>Adapteur für konsolle</i> / Adaptador pro consola (Fig.18)	page 40-41
Connectors, contacts, tools / <i>Contatti, connettori, utensili</i> / Connecteurs, contacts, outils / <i>Konnektors, kontakts,</i> <i>werkzeug</i> / Contacto, conector, utensilio (Fig.19)	page 42-43
General index / <i>Indice generale</i> / Index général / <i>Generalindex</i> / Indice general	page 44-45
Note / <i>Note</i> / <i>Note</i> / <i>Hinweise</i> / <i>Notas</i>	page 46-47

<https://www.ebooklibonline.com>

Hello dear friend!

Thank you very much for reading.

Enter the link into your browser.

The full manual is available for immediate download.

<https://www.ebooklibonline.com>

LEGEND OF SYMBOLS USED IN THIS HANDBOOK / *LEGENDA SIMBOLOGIA IMPIEGATA SUL CATALOGO* / LEGENDE SYMBOLIQUE UTILISÉE SUR CATALOGUE / *LEGENDE DER KATALOGSYMBOL* / LEYENDA SIMBOLOGÍA EMPLEADA EN EL CATÁLOGO

◆ Optional / *Optional* / Optionnel / *Wahlfrei* / Opcional

* Seals kit / *Kit guarnizioni* / Kit joints / *Dichtungssatz* / Kit de guarniciones

■ Aitem fitted on models with forks L=1000-1150mm and on models United Kingdom with forks L=1950-2150-2350mm / *Particolare presente solo nei modelli con forche L=mm1000-1150 e nei modelli United Kingdom con forche L=mm1950-2150-2350* /

Détail présent seulement pour les modeles avec fourches L=mm1000-1150 et pour les modeles United Kingdom avec fourches L=mm1950-2150-2350 /

Einzelteil nur an Gabel-Modellen vorhanden L=mm1000-1150 ; Einzelteil nur an Gabel-Modellen vorhanden L=mm1950-2150-2350 (United Kingdom) /

Detalle presente solamente en los modelos con horquillas L=mm1000-1150 y en los modelos United Kingdom con horquillas L=mm1950-2150-2350

* Aitem fitted on models for refrigerating rooms (- 30°) / *Particolare presente solo nei modelli per celle frigorifere (- 30°)* / Détail présent seulement pour les modeles pour cellules à glace (- 30°) / *Dieser Bestandteil befindet sich nur in Modellen für Eiskammer (- 30°)* / Detalle presente solamente en los modelos para cámara de refrigeración (- 30°)

Specify the following information when ordering spare parts:
Per ordinare parti di ricambio specificare:
 Pour les commander les pièces détachées veuillez préciser:
Zum Bestellen von Ersatzteilen bitte folgende Angaben machen:
 Para solicitar los repuestos especificar:

- truck model
- *tipo della macchina*
- type machine
- *Staplertyp*
- tipo de la máquina.

- table N°
- *N° della tavola*
- N° plan
- *Tafel-Nr.*
- N° de la máquina.

- quantity
- *quantità dei particolari richiesti*
- nombre de pièces
- *Erforderliche Stückzahl*
- cantidad de piezas solicitadas.

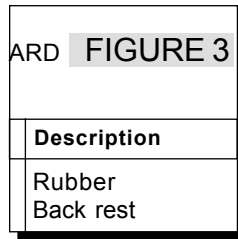
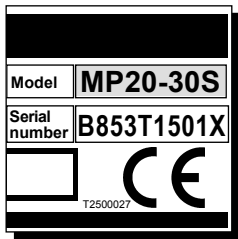

	Q.ty	Descri
00	1	Rubbe
00	1	Back
55	4	Screw
31	4	Backr
51	8	Elastic
92	4	Washe

MP20-30S B853T1501X FIGURE 3 277032100 4 Screw

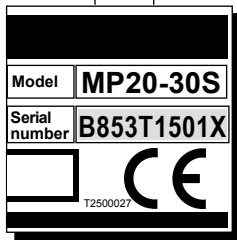

em	Part N°
1	277202000
2	277032100
3	272121200
4	273212200
5	277101000

Q.ty	Description
1	Rubber
1	Back rest
4	Screw
4	Screw
8	Elastic wash

- truck serial number
- *matricola della macchina*
- N° matricule
- *Seriennummer der Maschine*
- matrícula de la máquina.

- part number of required component
- *N° di codice del particolare richiesto*
- N° code de la pièce
- *Best. Nr. des erforderlichen Teils*
- N° de código de la pieza solicitada.

- part description
- *demoninazione del particolare richiesto*
- désignation de la pièce
- *Bezeichnung des erforderlichen Teils*
- denominación de la pieza solicitada.

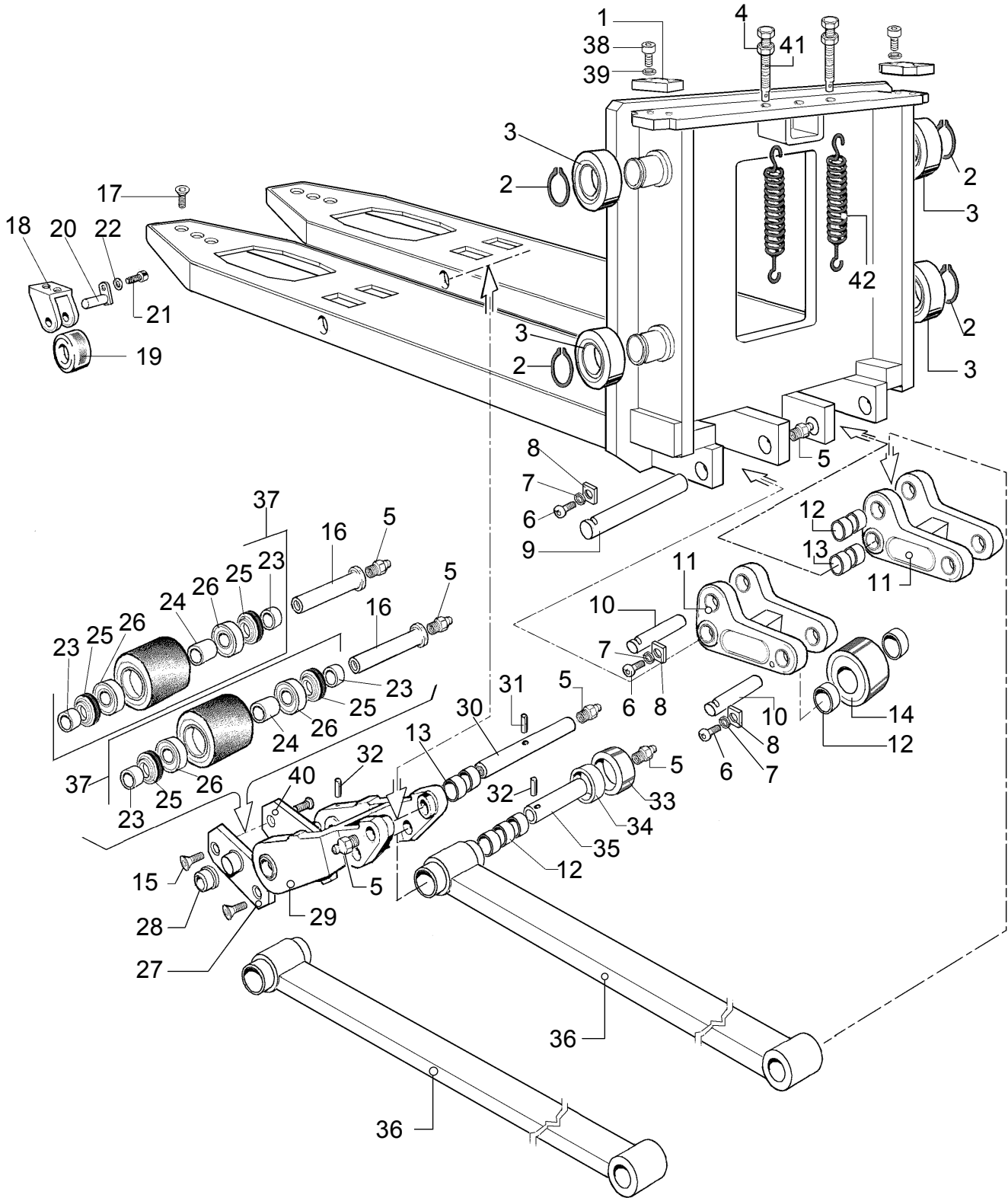

T2500451



Suggest:

For more complete manuals. Please go to the home page.

<https://www.ebooklibonline.com>

If the above button click is invalid. Please download this document first, and then click the above link to download the complete manual.

Thank you so much for reading

REF.	PART NO.	Q.TY	DESCRIPTION	DESCRIZIONE	DESIGNATION	BENENNUNG	DENOMINACIONES
1	273054200	2	Nylon guide	Pattini di guida	Guide en nylon	Führungsschieber	Patines guía
2	273087000	4	Snap ring	Seeger	Arretoi	Seeger-Ring	Seeger
3	273005700	4	Bearing	Cuscinetto	Roulement	Lager	Cojinete
4	449015044	2	Nut	Dado	Écrou	Mutter	Tuerca
5	273033400	14	Grease fitting	Ingrassatore	Graisseur	Schmiernippel	Engrasador
6	449001415	6	Screw	Vite	Vis	Schraube	Tornillo
7	449022016	6	Lock washer	Rosetta elastica	Rondelle souple	Federscheibe	Arandela elástica
8	273059700	6	Plate	Piatto	Plaque	Teller	Plato
9	273047100	2	Axle	Perno	Axe	Bolzen	Perno
10	273015800	4	Axle	Perno	Axe	Bolzen	Perno
11	273046900	2	Lever	Leva	Levier	Hebel	Palanca
12	273032800	14	Bushing	Boccola	Douille	Buchse	Buje
13	273011400	8	Bushing	Boccola	Douille	Buchse	Buje
14	277457400	2	Roller	Rullo regolazione	Rouleau	Stellrad	Perilla de regulac.
15	580001470	4	Screw	Vite	Vis	Schraube	Tornillo
16	273002800	4	Axle	Perno	Axe	Bolzen	Perno
17	900010217	4	Screw	Vite	Vis	Schraube	Tornillo
18	273045900	2	Support	Supporto	Support	Halter	Soporte
19	273045600	2	Lead-in roller	Rullo d'invito	Rouleau	Einfuhrrolle	Rodillo de invitac.
20	273002600	2	Axle	Perno	Axe	Bolzen	Perno
21	580006762	2	Screw	Vite	Vis	Schraube	Tornillo
22	449022016	2	Lock washer	Rosetta elastica	Rondelle souple	Federscheibe	Arandela elástica
23	273091000	2	Spacer	Distanziale	Entretoise	Distanzstück	Espaciador
24	273090900	1	Spacer	Distanziale	Entretoise	Distanzstück	Espaciador
25	580019702	2	Seal	Anelli di protezione	Bagues de protect.	Sicherungsringe	Anillos de protec.
26	273005500	2	Bearing	Cuscinetto	Roulement	Lager	Cojinete
27	273017600	2	Counter. rocker plate	Bilancino svasato	Palonnier	Pendelbecher	Balancín vaciado
28	273010300	4	Bushing	Boccola	Douille	Buchse	Buje
29	273015700	2	Connecting link	Biella	Bielle	Pleuel	Biela
30	273031300	2	Axle	Perno	Axe	Bolzen	Perno
31	449034085	2	Elastic pin	Spina elastica	Goupille élastique	Federstift	Enchufe elástico
32	277465900	4	Elastic pin	Spina elastica	Goupille élastique	Federstift	Enchufe elástico
33	273045700	2	Lead-in roller	Rullo d'invito	Rouleau	Einfuhrrolle	Rodillo de invitac.
34	277362700	2	Bushing	Boccola	Douille	Buchse	Buje
35	273097700	2	Axle	Perno	Axe	Bolzen	Perno
36	273098600	2	Tie rod (forks L=mm1000)	Tirante (forche L=mm1000)	Tirant (fourches L=mm1000)	Zugstange (Gabeln L=mm1000)	Tirante (horquillas L=mm1000)
36	277469300	2	Tie rod (forks L=mm 1150/1400/ 1600)	Tirante (forche L=mm1150/1400/ 1600)	Tirant (fourches L=mm1150/1400/ 1600)	Zugstange (Gabeln L=mm1150/1400/ 1600)	Tirante (horquillas L=mm1150/1400/ 1600)
36	277457200	2	Tie rod (forks L=mm1950/2150/ 2350C)	Tirante (forche L=mm1950/2150/ 2350C)	Tirant (fourches L=mm1950/2150/ 2350C)	Zugstange (Gabeln L=mm1950/2150/ 2350C)	Tirante (horquillas L=mm1950/2150/ 2350C)
36	277469400	2	Tie rod (forks L=mm2350L/2850)	Tirante (forche L=mm2350L/ 2850)	Tirant (fourches L=mm2350L/ 2850)	Zugstange (Gabeln L=mm2350L/2850)	Tirante (horquillas L=mm2350L/ 2850)
36	277780600	2	Tie rod (forks L=mm1950/2150 United Kingdom)	Tirante (forche L=mm1950/2150 United Kingdom)	Tirant (fourches L=mm1950/2150 United Kingdom)	Zugstange (Gabeln L=mm1950/2150 United Kingdom)	Tirante (horquillas L=mm1950/2150 United Kingdom)
36	277780700	2	Tie rod (forks L=mm2350 United Kingdom)	Tirante (forche L=mm2350 United Kingdom)	Tirant (fourches L=mm2350 United Kingdom)	Zugstange (Gabeln L=mm2350 United Kingdom)	Tirante (horquillas L=mm2350 United Kingdom)
37	273062500	4	Polyurethane wheel ass'y	Ass. rullo adiprene	Ens. roue vulkollan	Satz Adipren-Rolle	Eje rodillo poliur.
38	449002142	4	Screw	Vite	Vis	Schraube	Tornillo
39	449021006	4	Washer	Rosetta	Rondelle	Unterlegscheibe	Arandela
40	273098100	2	Through rocker plate	Bilancino passante	Palonnier	Pendeldurchgangsplatte	Balancín pasante
41	273073200	2	Screw	Vite	Vis	Schraube	Tornillo
42	273093600	2	Spring	Molla	Ressort	Feder	Resorte

 From serial N° / Da matr. /
 Du matr. / Ab. seriennummer /
 Desde la matr. :

 Until serial N° / Fino a matr. /
 Jusq' matr. / Bis zur serien-Nr. /
 Hasta la matr. :

 With the exception of /
 Ad esclusione di / À l'exclusion de /
 Mit ausnahme von / Excepto :

 Including / Compreso / Avec /
 Einschließlich / Con :

B853T1501X

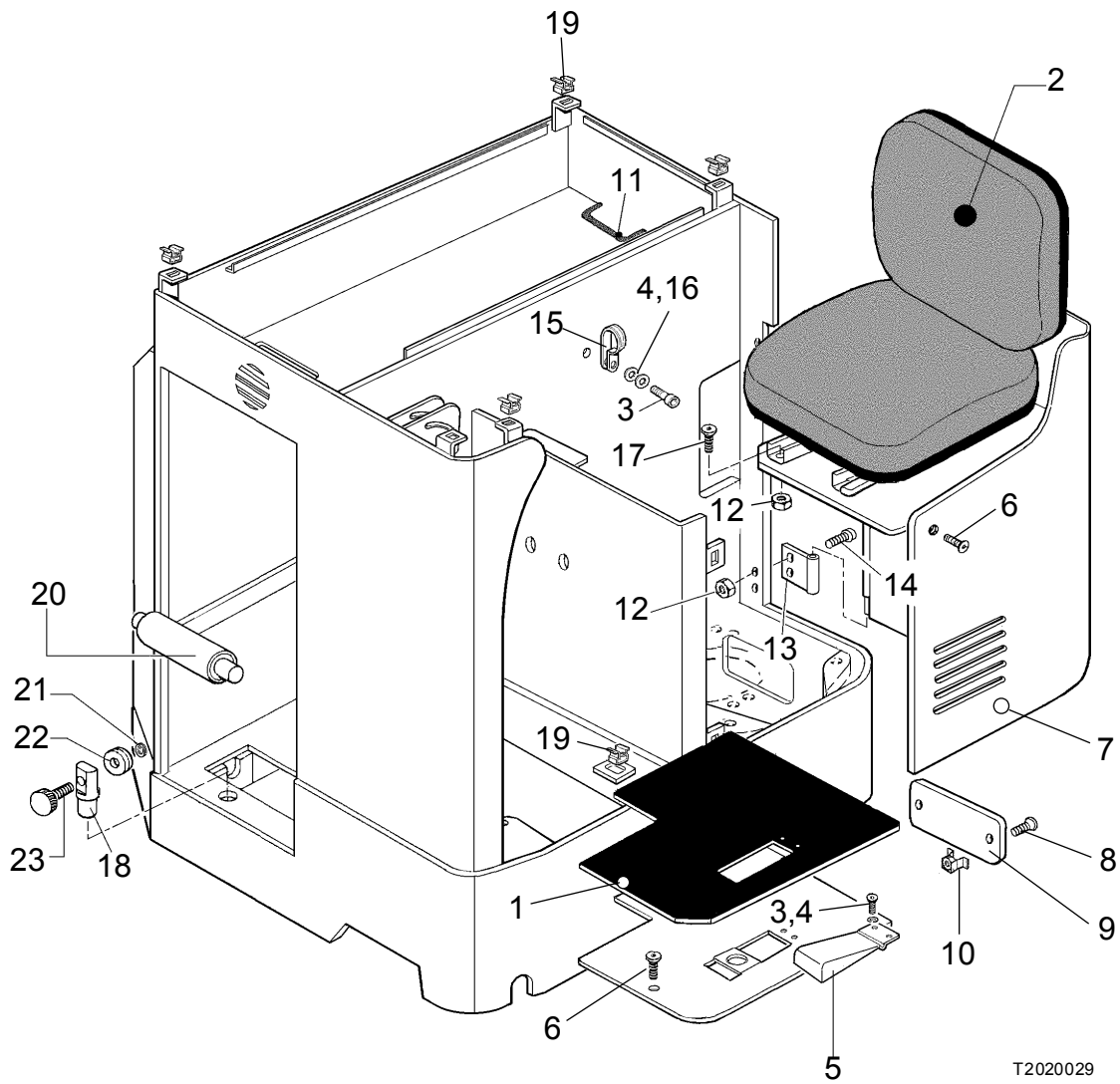

T2020029

<https://www.ebooklibonline.com>

Hello dear friend!

Thank you very much for reading.

Enter the link into your browser.

The full manual is available for immediate download.

<https://www.ebooklibonline.com>