

GDP/GLP16-20AF (B810)



YP990096

1	GENERAL TRUCK	
2	DIESEL ENGINE (2.5L)	
3	LPG ENGINE (2.0L)	
4	FUEL SYSTEM	
5	ELECTRICAL SYSTEM	
6	STEERING SYSTEM	
7	BRAKE SYSTEM	
8	TRANSMISSION	
9	HYDRAULIC SYSTEM	
10	MAST-TWO STAGE LIMITED FREE-LIFT	
11	MAST-THREE STAGE FULL FREE-LIFT	
12	MAST-TWO STAGE FULL FREE-LIFT	
13	FORKS, LOAD BACKREST, AND MAST INSTALLATION	
14	OPTIONS	
15	NUMERICAL INDEX	

ALPHABETICAL INDEX

DESCRIPTION	PAGE NO.
A	
ABBREVIATIONS QUICK REFERENCE SHEET	viii
AIR FILTER	
GDP 16/20 AF.....	4.16
GLP 16/20 AF	4.14
ALPHABETICAL INDEX.....	i
ALTERNATOR	5.12
AUXILIARY TUBES	
TWO AND THREE STAGE FULL FREE-LIFT	
FOUR FUNCTION GROUP	14.16
B	
BACK-UP ALARM	14.26
BATTERY.....	5.20
BEACON LAMP.....	14.32
BRAKE ASSEMBLY	7.6
BRAKE LINES.....	7.10
BRAKE MASTER CYLINDER.....	7.12
BRAKE PEDAL LINKAGE	7.2
C	
CAMSHAFT AND VALVES	
GDP 16/20 AF.....	2.12
GLP 16/20 AF	3.14
CARBURETOR	
LPG OPEN LOOP	
GLP 16/20 AF.....	4.10
CARRIAGE	
SIX ROLLER	
THREE STAGE FULL FREE-LIFT	11.18
TWO STAGE FULL FREE-LIFT	12.20
TWO STAGE LIMITED FREE-LIFT	10.12
CHARGE PUMP.....	8.20
CONNECTING HOSES.....	9.24
CONTROL VALVE	8.12
FOUR FUNCTION WITH UNLOADER VALVE	9.20
THREE FUNCTION WITHOUT UNLOADER VALVE.....	9.16
COOLING SYSTEM	
GDP 16/20 AF.....	2.30
GLP 16/20 AF	3.26
COUNTERWEIGHT	1.8
CRANKSHAFT AND PISTON	
GDP 16/20 AF.....	2.14
GLP 16/20 AF	3.12
CYLINDER BLOCK	
GDP 16/20 AF.....	2.8
GLP 16/20 AF	3.8

<https://www.ebooklibonline.com>

Hello dear friend!

Thank you very much for reading.

Enter the link into your browser.

The full manual is available for immediate download.

<https://www.ebooklibonline.com>

DESCRIPTION	PAGE NO.
C (continued)	
CYLINDER HEAD	
GDP 16/20 AF.....	2.10
GLP 16/20 AF.....	3.10
D	
DIFFERENTIAL.....	8.10
DISTRIBUTOR	
GLP 16/20 AF.....	5.10
DRIVE AXLE.....	8.14
DRIVE WHEEL AND TIRE	
GDP/GLP 20 AF	
SHEET 1 OF 2.....	14.18
SHEET 2 OF 2.....	14.20
DRIVE, TURN, AND SIDELIGHTS	
⇒S/N B810B-03239A.....	14.28
S/N B810B-03240A⇒.....	14.30
E	
ELECTRICAL	
COWL.....	5.7
ELECTRICAL SYSTEM	
GDP 16/20 AF.....	5.4
2.5L.....	2.32
GLP 16/20 AF.....	5.2
2.0L.....	3.22
END PLATE ASSEMBLY	
GDP 16/20 AF.....	8.22
GLP 16/20 AF.....	8.21
ENGINE COVER.....	1.6
ENGINE MOUNT	
GDP 16/20 AF.....	2.2
GLP 16/20 AF.....	3.2
F	
FENDER.....	1.20
FLYWHEEL.....	8.26
FOOT DIRECTIONAL CONTROL PEDAL.....	4.34
FOOT DIRECTIONAL CONTROL PEDAL AND BRACKET ASSEMBLY.....	4.32
FOOT DIRECTIONAL CONTROL PEDAL LINKAGE	
GDP 16/20 AF.....	4.30
GLP 16/20 AF.....	4.28
FORKS	
1600 KG.....	13.4
2000 KG.....	13.5
FRAME AND FLOORPLATES.....	1.2
FREE LIFT	
THREE STAGE FULL FREE-LIFT.....	11.10
TWO STAGE FULL FREE-LIFT.....	12.8

DESCRIPTION	PAGE NO.
F (continued)	
FREE-LIFT CYLINDER	
THREE STAGE FULL FREE-LIFT	11.16
TWO STAGE FULL FREE-LIFT	12.18
FUEL FILTER	
GDP 16/20 AF	2.24
FUEL SYSTEM	
GDP 16/20 AF	
2.5L	2.22
GLP 16/20 AF	4.4
2.0L	3.24
FUEL TANK AND LINES	
GDP 16/20 AF	4.18
G	
GOVERNOR	
GLP 16/20 AF	4.12
H	
HEADER HOSE	
FOUR FUNCTION	
THREE STAGE FULL FREE-LIFT	11.22
TWO STAGE FULL FREE-LIFT	12.26
THREE FUNCTION	
THREE STAGE FULL FREE-LIFT	11.20
TWO STAGE FULL FREE-LIFT	12.22
TWO STAGE LIMITED FREE-LIFT	10.14
HOOD LATCH	1.22
HOW TO FIND THE DESIRED PART NUMBER	x
HOW TO USE THE ILLUSTRATED PARTS MANUAL	x
HYDRAULIC CLUTCH	
FORWARD AND REVERSE	8.8
HYDRAULIC PUMP	
GDP 16/20 AF	9.5
GLP 16/20 AF	9.6
HYDRAULICS GROUP	9.2
I	
IDENTIFICATION OF ATTACHMENT AND SIDE-SHIFT CARRIAGE SERIAL NUMBERS	xiii
IDENTIFICATION OF MAST SERIAL NUMBER	xii
IDENTIFICATION OF TRUCK SERIAL NUMBER	xi
INJECTION PUMP	
GDP 16/20 AF	2.28
INNER MAST	
THREE STAGE FULL FREE-LIFT	11.6
TWO STAGE FULL FREE-LIFT	12.4
TWO STAGE LIMITED FREE-LIFT	10.4
INSTRUMENT PANEL	5.18
INTAKE AND EXHAUST MANIFOLD	

DESCRIPTION	PAGE NO.
I (continued)	
GLP 16/20 AF	3.18
INTEGRAL SIDE-SHIFT CARRIAGE	
THREE STAGE FULL FREE-LIFT	14.10
TWO STAGE FULL FREE-LIFT	14.8
TWO STAGE LIMITED FREE-LIFT	14.6
INTEGRAL SIDE-SHIFT CYLINDER	14.12
INTEGRAL SIDE-SHIFT HYDRAULIC HOSES	
TWO STAGE AND THREE STAGE FULL FREE-LIFT	14.15
TWO STAGE LIMITED FREE-LIFT	14.14
INTERMEDIATE MAST	
THREE STAGE FULL FREE-LIFT	11.4
L	
LABELS	1.17
LIFT	
TWO STAGE LIMITED FREE-LIFT	10.6
LIFT CYLINDER	
LEFT HAND	
TWO STAGE LIMITED FREE-LIFT	10.8
RIGHT HAND	
TWO STAGE LIMITED FREE-LIFT	10.10
LIGHTS BACK-UP AND BRAKE	
S/N B810B04150B⇒	14.38
LOAD BACKREST EXTENSION	13.2
M	
MAIN CYLINDER	
LEFT HAND	
THREE STAGE FULL FREE-LIFT	11.12
TWO STAGE FULL FREE-LIFT	
⇒S/N A558B03806	12.10
S/N A558B03807⇒	12.12
RIGHT HAND	
THREE STAGE FULL FREE-LIFT	11.14
TWO STAGE FULL FREE-LIFT	
⇒S/N A558B03806	12.14
S/N A558B03807⇒	12.16
MAIN LIFT	
THREE STAGE FULL FREE-LIFT	11.8
TWO STAGE FULL FREE-LIFT	12.6
MANIFOLDS	
GDP 16/20 AF	2.20
MAST INSTALLATION	13.6
MIRROR	14.44

DESCRIPTION	PAGE NO.
N	
NOISE REDUCTION	
ENGINE COVER	1.24
FRAME	1.26
NOZZLE HOLDER	
GDP 16/20 AF.....	2.26
O	
OIL PUMP	
GDP 16/20 AF.....	2.18
OIL PUMP AND FILTER	
GLP 16/20 AF	3.20
OIL SUMP AND TIMING GEAR	
GLP 16/20 AF	3.16
OUTER MAST	
THREE STAGE FULL FREE-LIFT	11.2
TWO STAGE FULL FREE-LIFT	12.2
TWO STAGE LIMITED FREE-LIFT.....	10.2
OVERHEAD GUARD.....	1.28
P	
PARK BRAKE LEVER	7.14
PUMP DRIVE	
GDP 16/20 AF.....	9.26
GLP 16/20 AF	9.27
R	
RADIATOR	
GDP 16/20 AF.....	2.6
GLP 16/20 AF	3.6
REGULATOR	
OPEN LOOP	
GLP 16/20 AF.....	4.8
S	
SEAT	
FULL SUSPENSION	
SHEET 1 OF 2	1.10
SHEET 2 OF 2	1.12
NON-SUSPENSION	1.14
SHIFT LEVER	8.24
SIDE-SHIFT CARRIAGE	14.2
SIDE-SHIFT CYLINDER	14.4
SOLENOID VALVE	
⇒D/B 10/2003	8.16
STARTER MOTOR	
GDP 16/20 AF.....	5.16
GLP 16/20 AF	5.14
STEER AXLE	6.4
STEERING COLUMN.....	6.2

DESCRIPTION	PAGE NO.
S (continued)	
STEERING CYLINDER	6.8
STEERING PUMP	6.6
STROBE LIGHT	14.34
T	
TAIL LIGHT	
⇒S/N B810B04149B	14.36
TANK	
LPG	
GLP 16/20 AF	4.2
THROTTLE PEDAL LINKAGE	
FORWARD AND REVERSE LEVER	
GDP 16/20 AF	
⇒S/N B810B-2183Z	4.20
S/N B810B-2184Z⇒	4.22
GLP 16/20 AF	
⇒S/N B810B-2204Z	4.24
S/N B810B-2205Z⇒	4.26
TILT CYLINDER	9.8
TIMING GEAR COVER AND OIL SUMP	
GDP 16/20 AF	2.16
TRANSMISSION GEARS	8.6
TRANSMISSION HOUSING	8.2
TRANSMISSION HYDRAULIC LINES	8.18
U	
UPSWEPT EXHAUST	
GDP 16/20 AF	2.4
GLP 16/20 AF	3.4
V	
VALVE ATTACHING PARTS	
FOUR FUNCTION	9.14
THREE FUNCTION	9.10
W	
WHEEL AND TIRE	
DRIVE WHEEL	14.22
STEER WHEEL	14.24
WIRE HARNESS	
CHASSIS	
GDP 16/20 AF	5.23
COWL WITH FOOT DIRECTIONAL CONTROL PEDAL	
GP/GLP/GDP	5.26
COWL WITH FORWARD/REVERSE LEVER	
GP/GLP/GDP 16/20 AF	5.24
ENGINE	

DESCRIPTION	PAGE NO.
-------------	----------

W (continued)

GLP 16/20 AF.....	5.22
REAR LIGHT	
S/N B810B04150B⇒.....	14.42
SEAT SWITCH.....	5.28
TAIL LIGHT	
⇒S/N B810B04149B.....	14.40

1	GENERAL TRUCK
---	---------------

**SECTION 1
GENERAL TRUCK**

DESCRIPTION	PAGE
COUNTERWEIGHT	1.8
ENGINE COVER	1.6
FENDER.....	1.20
FRAME AND FLOORPLATES.....	1.2
HOOD LATCH	1.22
LABELS.....	1.17
NOISE REDUCTION	
ENGINE COVER	1.24
FRAME	1.26
OVERHEAD GUARD.....	1.28
SEAT	
FULL SUSPENSION	
SHEET 1 OF 2	1.10
SHEET 2 OF 2	1.12
NON-SUSPENSION	1.14

FRAME AND FLOORPLATES

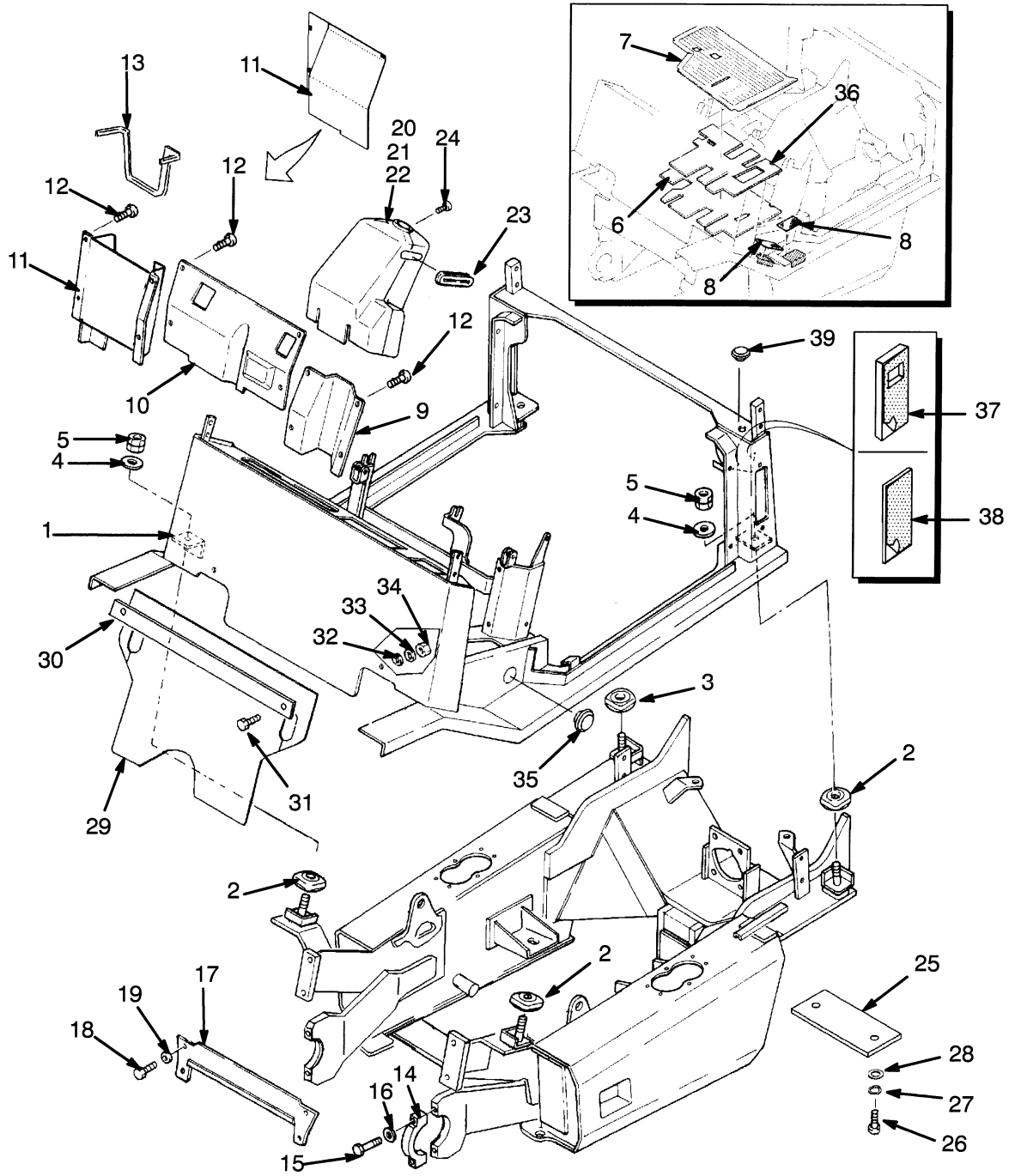

YP120549



FRAME AND FLOORPLATES

ITEM	PART NO.	DESCRIPTION	QTY
1	524141602	Module (Upper) (Standard).....	1
2	916703300	Insulator.....	3
3	916704300	Insulator.....	1
4	909903402	Washer.....	4
5	907968405	Nut.....	4
6	bdf 923167401	Floorplate.....	1
6	a 926148400	Floorplate.....	1
6	beg 915899601	Floorplate.....	1
7	bdf 904061701	Floormat.....	1
7	beg 907239701	Floormat.....	1
7	a 907669705	Floormat.....	1
8	909472304	Anti-Slip Tread (Step).....	4
9	b 910279600	Cover (LH) (Cowl).....	1
10	bdf 912394600	Cover (Cowl) (Center).....	1
10	aeg 912394600	Cover (Cowl) (Center).....	1
10	beg 920171600	Cover (Cowl) (Center).....	1
11	b 919970401	Cover (RH) (Cowl).....	1
11	a 925730400	Cover (Cowl).....	1
12	904184103	Screw.....	6
13	912291315	Trim.....	1
14	919920400	Cap.....	2
15	449001389	Capscrew.....	4
16	940101908	Washer.....	4
17	920127400	Plate.....	1
18	449001179	Capscrew.....	4
19	909903401	Washer.....	4
20	915483401	Cover Assembly (Forward/Reverse).....	1
20	909951601	Cover (Front).....	1
20	909950601	Cover (Rear).....	1
21	915483402	Cover Assembly (Without Turn Signal).....	1
21	909951602	Cover (Front).....	1
21	909950602	Cover (Rear).....	1
22	a 915483403	Cover Assembly.....	1
22	909951603	Cover (Front).....	1
22	909950603	Cover (Rear).....	1
23	921698300	Boot.....	AR
23	a 934592300	Boot.....	1
24	909904403	Screw.....	5
25	921057300	Cover.....	2
26	449001302	Capscrew.....	4
27	449022013	Lockwasher.....	4
28	449021006	Washer.....	4
29	c 912875600	Cover.....	1
30	c 926074300	Plate.....	1
31	c 932729905	Capscrew.....	2
32	c 904310402	Lockwasher.....	2
33	449022016	Lockwasher.....	2
34	c 449015014	Nut.....	2
35	c 920600400	Cap.....	2
36	cdf 915163401	Pad.....	1

FRAME AND FLOORPLATES

ITEM	PART NO.	DESCRIPTION	QTY
36	ceg 931171401	Pad	1
37	c 922815301	Pad (GDP 16-20 AF)	1
38	c 920053409	Pad (GDP 16-20 AF)	1
39	c 910543108	Cap.....	1

FOOTNOTES:

- a** Foot Directional Control Pedal
- b** Forward and Reverse Lever
- c** Low Noise
- d** ⇒ S/N B810B-02183Z Diesel
- e** S/N B810B-02184Z ⇒ Diesel
- f** ⇒ S/N B810B-02204Z LPG
- g** S/N B810B-02205Z ⇒ LPG

ENGINE COVER

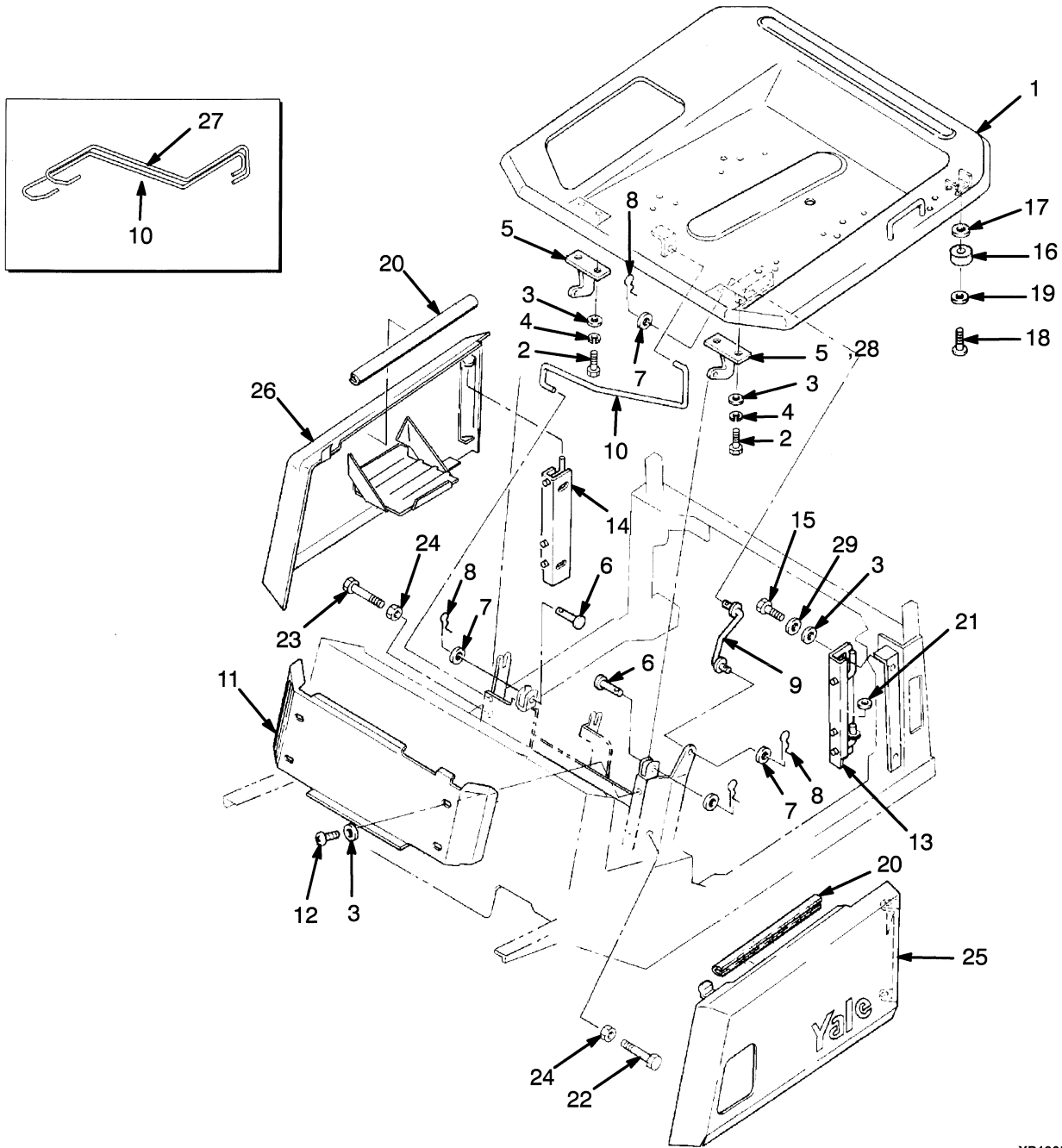

YP120551

ITEM	PART NO.	DESCRIPTION	QTY
1	a 908594741	Cover	1
1	b 908594742	Cover	1
2	449001013	Capscrew.....	4
3	023604600	Washer	8
3	504226242	Washer (Optional)	8
4	449022016	Lockwasher	8
5	c 922307300	Hinge	1
5	d 922307300	Hinge	2
6	912326300	Pin	2
7	449021006	Washer	4
8	965801908	Cotter Pin	4
9	922134300	Support.....	1
10	922650402	Spring	1
11	909835611	Plate	1
12	932729901	Capscrew.....	1
13	915340401	Hinge (LH)	1
14	915340402	Hinge (RH).....	1
15	449001415	Capscrew.....	4
16	917426300	Cushion (Rubber)	2
17	502398907	Washer	AR
18	580032373	Capscrew.....	2
19	449021001	Washer	2
20	912291312	Trim.....	2
21	449021006	Washer	AR
22	449001073	Capscrew.....	1
23	449001202	Capscrew.....	1
24	449015014	Nut.....	2
25	911833614	Door (LH) (GLP 16-20 AF)	1
25	911834612	Door (LH) (GDP 16-20 AF).....	1
26	912684612	Door (RH) (GDP 16-20 AF)	1
26	912685612	Door (RH) (GLP 16-20 AF).....	1
27	922650401	Spring	1
28	c 524148688	Hinge	1
29	520037852	Washer	4

FOOTNOTES:

- a** ⇒ S/N B810B-01822Y
- b** S/N B810B-01823Y ⇒
- c** ⇒ S/N B810B-02144Z
- d** S/N B810B-02145Z ⇒

COUNTERWEIGHT

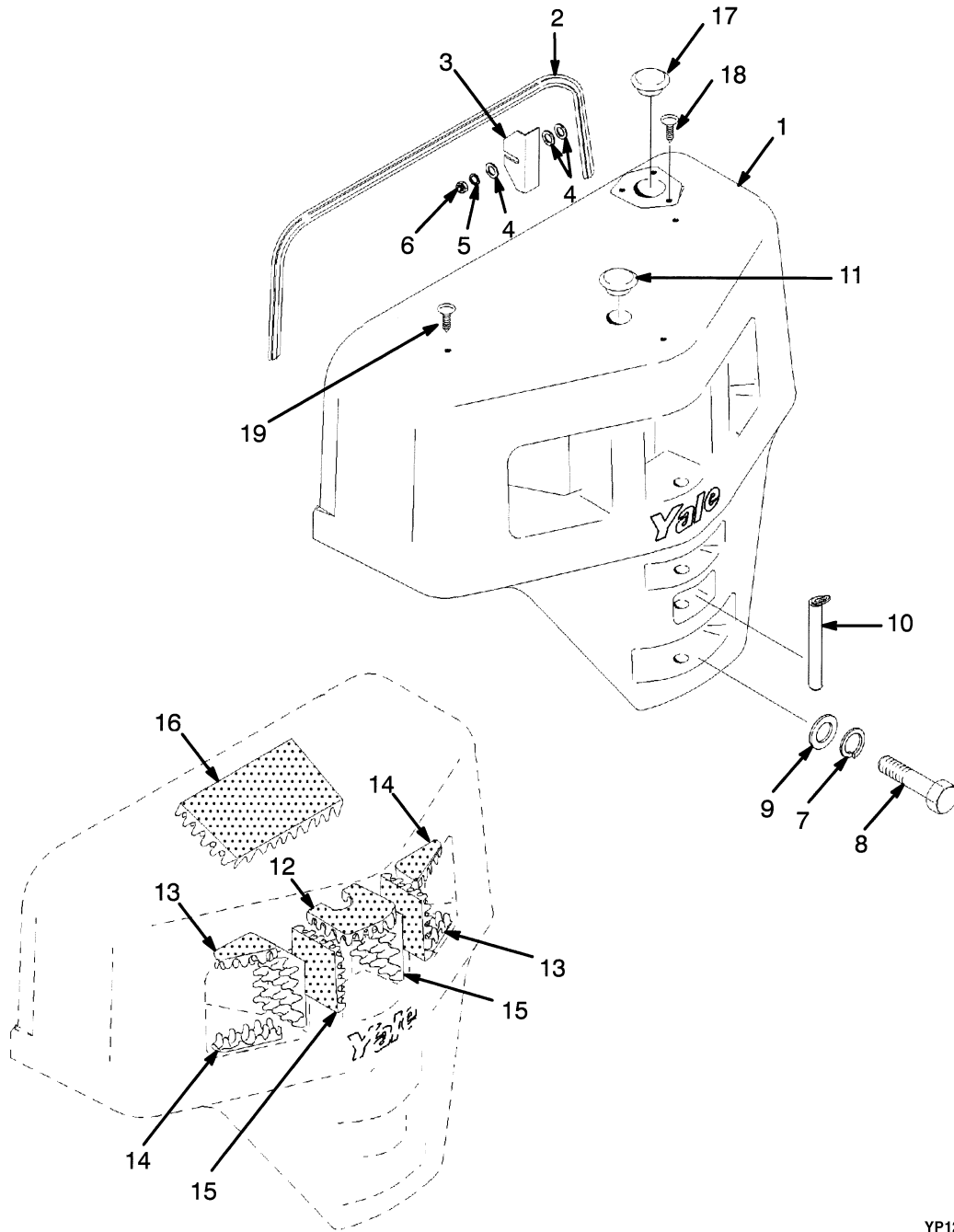

YP120552



COUNTERWEIGHT

ITEM	PART NO.	DESCRIPTION	QTY
1	905320700	Counterweight (GLP/GDP 16 AF)	1
1	905322700	Counterweight (GLP/GDP 20 AF)	1
2	900008212	Seal	1
3	922410300	Shim	AR
4	504226242	Washer	4
5	449022016	Lockwasher	4
6	930113903	Screw.....	4
7	955400911	Lockwasher	2
8	449001405	Capscrew.....	2
9	910590100	Washer	2
10	924230300	Pin	1
11	917595300	Cap.....	1
12	920694401	Pad (GDP 16-20 AF)	1
13	920695401	Pad (GDP 16-20 AF)	2
14	920696401	Pad (GDP 16-20 AF)	2
15	921773301	Pad (GDP 16-20 AF)	4
16	916731401	Pad (GDP 16-20 AF)	1
17	917595300	Cap.....	1
18	504241795	Fastener	3

SEAT (FULL SUSPENSION) (SHEET 1 OF 2)

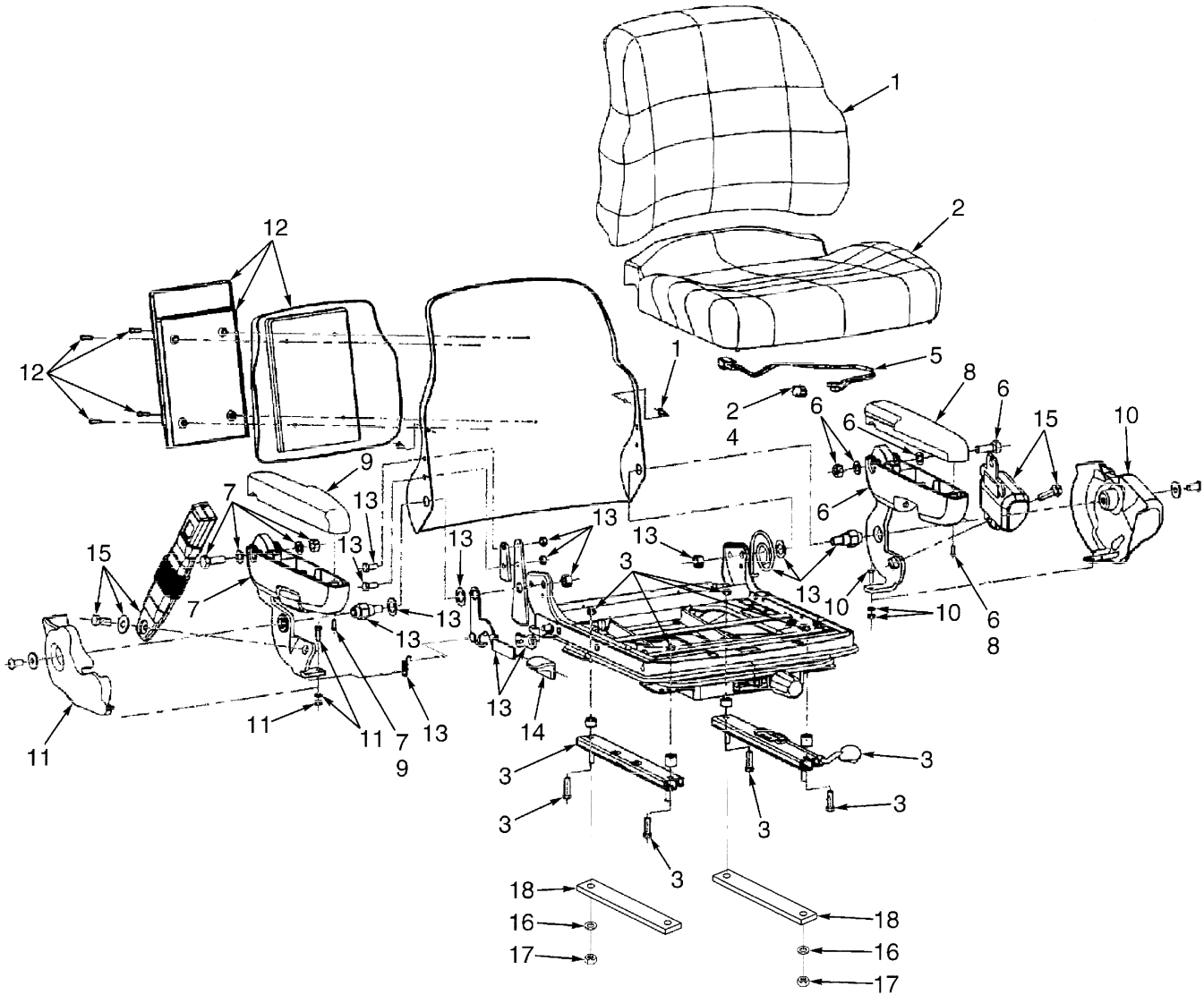

YP120553



Suggest:

For more complete manuals. Please go to the home page.

<https://www.ebooklibonline.com>

If the above button click is invalid. Please download this document first, and then click the above link to download the complete manual.

Thank you so much for reading



SEAT
(FULL SUSPENSION) (SHEET 1 OF 2)

ITEM	PART NO.	DESCRIPTION	QTY
	524139223	Full Suspension Seat.....	1
	524139224	Full Suspension Seat (Fabric)	1
1	524139579	Back Cushion	1
1	524139580	Back Cushion (Fabric).....	1
2	524139581	Seat Cushion (Fabric)	1
2	580023146	Seat Cushion (Vinyl)	1
3	580013409	Slider Kit.....	1
4	580013410	Switch (Seat).....	1
5	580013411	Wire Harness	1
6	580013412	Armrest (LH) (LH).....	1
7	580013413	Armrest (RH) (RH)	1
8	580013414	Cap (LH).....	1
9	580013415	Cap (RH)	1
10	580013416	Cover (LH).....	1
11	580013417	Cover (RH)	1
12	580013418	Holder Kit	1
13	580013426	Recliner Kit.....	1
14	580013427	Recliner Knob.....	1
15	580013428	Seat Belt Kit	1
16	023604600	Washer	4
17	504238298	Nut.....	4
18	931437301	Spacer (RH) (GLP 16 AF)	1
18	931437301	Spacer (GLP 20 AF, GDP 16-20 AF).....	2
18	936060301	Spacer (LH) (GLP 16 AF).....	1

SEAT (FULL SUSPENSION) (SHEET 2 OF 2)

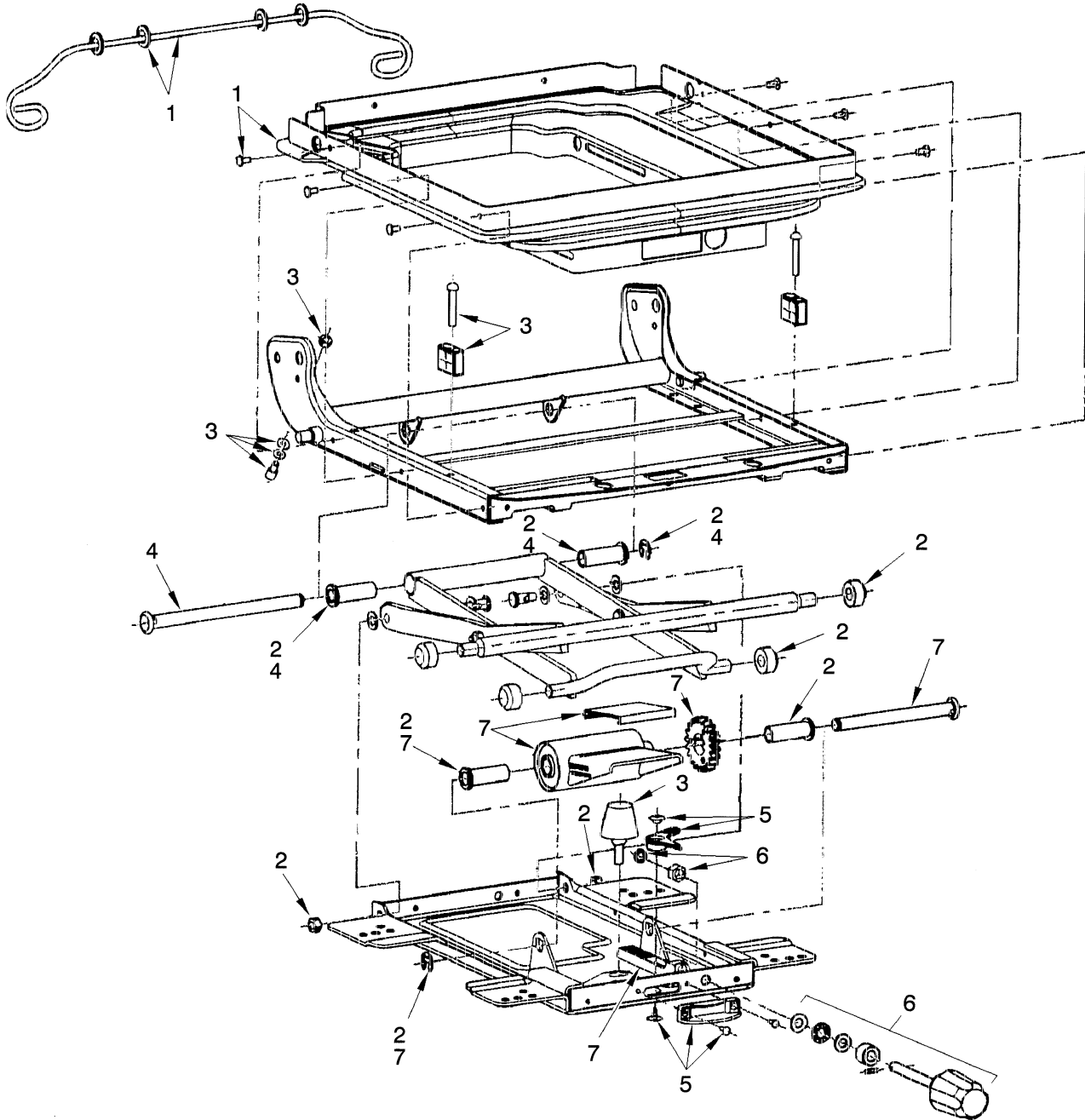

YP120554

<https://www.ebooklibonline.com>

Hello dear friend!

Thank you very much for reading.

Enter the link into your browser.

The full manual is available for immediate download.

<https://www.ebooklibonline.com>