

GDP/GLP20-30RF/TF

(A875)



YP990083

1	GENERAL TRUCK	
2	DIESEL ENGINE (2.5 AND 3.0L)	
3	LPG ENGINE (2.0 AND 2.2L)	
4	LPG ENGINE (3.0L)	
5	FUEL SYSTEM	
6	ELECTRICAL SYSTEM	
7	STEERING SYSTEM	
8	BRAKE SYSTEM	
9	TRANSMISSION	
10	HYDRAULIC SYSTEM	
11	MAST-TWO STAGE LIMITED FREE-LIFT	
12	MAST-THREE STAGE FULL FREE-LIFT	
13	MAST-TWO STAGE FULL FREE-LIFT	
14	FORKS, LOAD BACKREST, AND MAST INSTALLATION	
15	OPTIONS	
16	NUMERICAL INDEX	

ALPHABETICAL INDEX

DESCRIPTION	PAGE NO.
A	
ABBREVIATIONS QUICK REFERENCE SHEET	xiv
AIR CLEANER AND CRANKCASE BREATHER	
3.0L LPG	
LOW EMISSIONS	5.64
AIR CLEANER AND MOUNTING	
S/N A875B-13058⇒	5.58
AIR FILTER	
DIESEL	
⇒S/N A875B-13057	5.66
S/N A875B-13058⇒	5.68
GM 3.0L	
GLP 20-25 RF/TF, 30 TF	
S/N A875B-15397⇒	5.62
⇒S/N A875B-15396	5.60
⇒S/N A875B-10736 (FE), ⇒S/N A875B-10761 (F2)	5.54
S/N A875B-10737⇔S/N A875B-13057Y (FE), S/N A875B-10762⇔S/N A875B-13057Y (F2)	5.56
ALPHABETICAL INDEX	i
ALTERNATOR	
GM 3.0L LPG	
⇒S/N A875B-16869Z	6.48
XA/HA DIESEL AND FE/F2 LPG	6.46
ALTERNATOR MOUNTING	
GM 3.0L LPG	6.50
SERPENTINE BELT	
GM 3.0L LPG	6.52
AMBER FLASHING BEACON	15.42
B	
BACK-UP ALARM	
S/N A875B22174A⇒	15.60
⇒S/N A875B22174A	15.58
BEACON LAMP	15.40
BRAKE	8.6
BRAKE FITTINGS	
HYDOSTATIC TRANSMISSION	8.10
BRAKE LINES	8.8
BRAKE MASTER CYLINDER	8.12
BRAKE PEDAL LINKAGE	8.3
C	
CAB	
BLACK PVC WITH STEEL FRONT	1.30
STEEL	1.26
CAMSHAFT AND OIL PAN	
1998 THRU 2001 SERIES ENGINE	4.12
2002-2003 SERIES ENGINE	4.16

<https://www.ebooklibonline.com>

Hello dear friend!

Thank you very much for reading.

Enter the link into your browser.

The full manual is available for immediate download.

<https://www.ebooklibonline.com>

DESCRIPTION **PAGE NO.**

C (continued)

CAMSHAFT AND OIL SUMP	
LPG 3.0L	
2004-2005 SERIES ENGINE	
S/N A875B-24475A⇒	4.20
CAMSHAFT AND VALVES	
F2.....	3.54
FE	3.26
XA/HA	2.26
CARBURETOR	
LPG	
FE/F2	
⇒S/N A875B-3166	5.40
GM 3.0L.....	5.48
S/N A875B-3166⇔S/N A875B-10736 (FE).....	5.42
S/N A875B-3166⇔S/N A875B-10761 (F2).....	5.44
S/N A875B10736⇔S/N A875B26818B (FE), S/N A875B10761⇔S/N A875B26818B (F2)	5.46
POWERSHIFT GM 3.0L	
LPG	
S/N A875B-15397⇒	5.52
S/N A875B-8968⇔S/N A875B-15396Y.....	5.50
CARRIAGE	
SIX ROLLER	
TWO STAGE LIMITED FREE-LIFT	11.16
THREE STAGE FULL FREE-LIFT	12.32
TWO STAGE FULL FREE-LIFT	13.26
CONTROL VALVE	
T080 AND T081 POWERSHIFT	
⇒S/N A875B-2678W (T080), ⇒S/N A875B-2719W (T081)	9.22
T080, T081, T109, AND T110 POWERSHIFT	
S/N A875B-2679W (T080)⇒, S/N A875B-2720W (T081)⇒	9.26
CONVERTER	
LPG	
⇒S/N A875B-10736 (FE), ⇒S/N A875B-10761 (F2).....	5.32
COOLING	4.44
2003-2005 SERIES ENGINE WITH SERPENTINE BELT	4.48
COUNTERWEIGHT	1.12
CRANKSHAFT AND PISTON	
1998 THRU 2000 SERIES ENGINE	4.6
F2.....	3.52
FE	3.24
LPG 3.0L	
2004-2005 SERIES ENGINE	
S/N A875B-24475A⇒	4.10
XA/HA	2.28
CRANKSHAFT AND PISTONS	
2001-2003 SERIES ENGINE.....	4.8
CYLINDER	
TWO STAGE LIMITED FREE-LIFT	

DESCRIPTION	PAGE NO.
C (continued)	
GLP/GDP 20-25 RF/TF	11.10
CYLINDER BLOCK	
F2.....	3.48
FE	3.20
XA/HA	2.22
CYLINDER HEAD	
1998 THRU 2003 SERIES ENGINE	4.24
F2.....	3.50
FE	3.22
LPG 3,0L	
2004-2005 SERIES ENGINE	
S/N A875B-24475A⇒	4.28
XA/HA	2.24
D	
DIFFERENTIAL	
T080 AND T081 POWERSHIFT	
⇒D/B 07/1998.....	9.30
T080, T081, T109, AND T110 POWERSHIFT	
D/B 07/1998⇒.....	9.34
DISTRIBUTOR	
FE/F2 LPG	6.54
GM 3.0L LPG.....	6.56
DRIVE AXLE	
HYDROSTATIC	9.52
T080, T081, T109, AND T110 POWERSHIFT.....	9.38
DRIVE, TURN, AND REAR LIGHTS	
⇒S/N A875B-24003A.....	15.46
S/N A875B24004A⇔S/N A875B27639B.....	15.49
E	
ELECTRICAL	
COWL	6.4
F2.....	3.62
HYDROSTATIC	
GM 3.0L LPG	6.14
HYDROSTATIC TRANSMISSION.....	6.18
LOW EMISSIONS	
LPG 3.0L	
S/N A875B26957B⇒	6.34
LPG 3,0L	
2000 THRU 2005 SERIES ENGINE	4.32
POWERSHIFT	
GM 3.0L LPG	
⇒S/N A875B-4059	6.22
S/N A875B-4060⇔S/N A875B-15397Y.....	6.26
S/N A875B15397Y⇔S/N A875B26956B.....	6.30
THREE-WAY PURIFIER	

DESCRIPTION	PAGE NO.
E (continued)	
⇒S/N A875B-12120 INC. 13136-13149	6.12
XA/HA DIESEL	6.38
ELECTRICAL SYSTEM	
FE/F2 LPG	6.8
GM 3.0L LPG	6.20
ENGINE ASSEMBLY	
LPG 3.0L	
EPA COMPLIANT (2004 SERIES ENGINE)	4.2
ENGINE ELECTRICAL SYSTEM	
LOW EMISSIONS	
FE	3.34
WITH ELECTRONIC CONTROLS	
F2	3.64
FE	
S/N A875B-26819B⇒	3.36
XA/HA	2.52
ENGINE FUEL AND EMISSION CONTROLS	
S/N A875B-26819B⇒	3.74
ENGINE FUEL SYSTEM	
3.0L LPG	
LOW EMISSIONS	5.22
ENGINE MOUNT	4.36
FE/F2	3.4
XA/HA	2.2
ENGINE SHUTDOWN SYSTEM	6.42
EXHAUST	
2.0L AND 2.2L LPG	
LOW EMISSIONS	3.8
FE/F2	
STANDARD	3.6
LPG 3.0L	
LOW EMISSIONS	4.40
OVERHEAD	3.12
TWO-WAY CATALYTIC CONVERTER	3.10
XA/HA	2.4

F

FILTER AND LOCK-OFF VALVE	
LPG GM 3.0L	
⇒S/N A875B-10736 (FE), ⇒S/N A875B-10761 (F2)	5.30
FIRE EXTINGUISHER	15.62
FLOW VALVE	
⇒S/N A875B-015164W FE, XA, 3.0 GM, ⇒S/N A875B-05283W 3.0 GM, F2, ⇒S/N A875B-05402W HA..	10.44
FLYWHEEL AND TORQUE CONVERTER	4.34
FE/F2	3.46
XA/HA	2.20
FOOT DIRECTIONAL CONTROL PEDAL	5.100
FORKS	

DESCRIPTION	PAGE NO.
F (continued)	
GLP/GDP 20-25 RF/TF	14.6
GLP/GDP 30 TF	14.8
FRAME AND FLOORPLATES	1.2
FREE LIFT	
THREE STAGE FULL FREE-LIFT	12.12
TWO STAGE FULL FREE-LIFT	13.8
FREE-LIFT CYLINDER	
THREE STAGE FULL FREE-LIFT	12.24
GLP/GDP 20-25 RF/TF	12.28
GLP/GDP 30 TF	12.30
TWO STAGE FULL FREE-LIFT	13.22
FUEL	
F2 GLP	
S/N A875B-10761⇒	3.68
⇒S/N A875B-10761	3.66
FE GLP	
⇒S/N A875B-10735	3.38
S/N A875B-10736⇒	3.40
LPG	
OPEN LOOP	
S/N A875B-10736⇒ (FE), S/N A875B-10761⇒ (F2)	5.10
⇒S/N A875B-10736 (FE), ⇒S/N A875B-10761 (F2)	5.8
POWERSHIFT	
GM 3.0L LPG HYDROSTATIC	
⇒S/N A875B-15396Y	5.12
LPG GM 3.0L	
S/N A875B-15397⇒	5.16
FUEL FILTERING AND LOCK-OFF SYSTEM	
3.0L LPG	
LOW EMISSIONS	5.20
FUEL SYSTEM	
XA/HA	2.40
FUEL TANK	
DIESEL	5.28
G	
GOVERNOR	
F2	
S/N A875B-10761⇒ (F2)	5.38
FE/F2	
⇒S/N A875B-10760 (F2)	5.36
H	
HEADER HOSE	
THREE STAGE FULL FREE-LIFT	
⇒S/N B508B35044, ⇒S/N B563B18426	12.34
S/N B508B35045⇒, S/N B563B18427⇒	12.38
TWO STAGE FULL FREE-LIFT	

DESCRIPTION	PAGE NO.
H (continued)	
⇒S/N B509B-04943, ⇒S/N B564B-03938	13.28
S/N B509B-04944⇒, S/N B564B-03939⇒	13.32
TWO STAGE LIMITED FREE-LIFT	
⇒S/N B507B-020588, ⇒S/N B562B-15688	11.18
S/N B507B-20589⇒, S/N B562B-15688⇒	11.22
HEATER ASSEMBLY	
2.0L, 2.2L GLP, 2.5L, AND 3.0L DIESEL	1.32
3.0L GLP	1.34
HOOD AND SIDE DOORS	
HOOD LINER	1.10
HOW TO FIND THE DESIRED PART NUMBER	
HOW TO USE THE ILLUSTRATED PARTS MANUAL	
HYDRAULIC	
FE/F2/GM/XA/HA	
S/N A875B-10872⇔S/N A875B-10943	10.10
FE/F2/XA/HA	
⇒S/N A875B-10871	10.2
GM 3.0L	
⇒S/N A875B-10871	10.6
S/N A875B-10944⇒	10.22
HYDRAULIC HOSES	
INTEGRAL SIDE-SHIFT	
TWO STAGE FULL FREE-LIFT AND THREE STAGE FULL FREE-LIFT	15.27
TWO STAGE LIMITED FREE-LIFT	15.26
HYDRAULIC PUMP	
DOUBLE GEAR	
SHEET 1 OF 3	10.38
SHEET 2 OF 3	10.40
SHEET 3 OF 3	10.42
HYDROSTATIC TRANSMISSION	
SINGLE GEAR	
SHEET 1 OF 3	10.32
SHEET 2 OF 3	10.34
SHEET 3 OF 3	10.36
HYDRAULIC SYSTEM	
HYDROSTATIC PUMP	10.26
HYDROSTATIC TRANSMISSION	
⇒S/N A875B-10871	10.14
S/N A875B-10872⇒	10.18
WITH THROTTLE-UP	10.30

I

IDENTIFICATION OF ATTACHMENT AND SIDE-SHIFT CARRIAGE SERIAL NUMBERS	xix
IDENTIFICATION OF MAST SERIAL NUMBER	xviii
IDENTIFICATION OF TRUCK SERIAL NUMBER	xvii
INJECTION PUMP	
XA/HA	2.48
INNER MAST	

DESCRIPTION	PAGE NO.
-------------	----------

I (continued)

THREE STAGE FULL FREE-LIFT	12.6
TWO STAGE FULL FREE-LIFT	13.4
TWO STAGE LIMITED FREE-LIFT	11.4
INPUT AND COUNTER CLUTCH	
T080 AND T081 POWERSHIFT	
⇒S/N A875B-15437Y (T081), ⇒S/N A875B-15478Y (T080) S/N T080B34674⇒, S/N T081B04225⇒	9.16
S/N A875B15438Y⇒, S/N A875B15479Y⇒ ⇒S/N T80B63835, ⇒S/N T81B09350.....	9.18
⇒S/N T080B-34673, ⇒S/N T081B-04224.....	9.14
T109 AND T110 POWERSHIFT	9.20
INSTRUMENT PANEL.....	6.44
INTERMEDIATE MAST	
THREE STAGE FULL FREE-LIFT	12.4

L

LABELS.....	1.37
LIFT	
TWO STAGE LIMITED FREE-LIFT.....	11.6
LIFTING EYE.....	15.2
LIGHTS, BACK-UP AND BRAKE	
S/N A875B27640B⇒	15.54
LIGHTS, REAR DRIVE AND TURN	
S/N A875B27640B⇒	15.52
LOAD BACKREST EXTENSION.....	14.2
LOW NOISE	1.40
LPG FUEL TANK AND MOUNTING	
FIXED	5.4
LPG REGULATOR	
3.0L LPG	
LOW EMISSIONS	5.26
LPG TANK BRACKET	
SWING OUT/DROP DOWN.....	5.6

M

MAIN CYLINDER	
GLP, GDP 20-25 RF/TF, RIGHT HAND	
TWO STAGE FULL FREE-LIFT	
S/N B509B4940⇒	13.15
GLP/GDP 20-25 RF/TF, LEFT HAND	
TWO STAGE FULL FREE-LIFT	
⇒S/N B509B4939	13.11
S/N B509B4940⇒	13.12
GLP/GDP 20-25 RF/TF, RIGHT HAND	
TWO STAGE FULL FREE-LIFT	
⇒S/N B509B4939	13.14
GLP/GDP 30 TF, LEFT HAND	
TWO STAGE FULL FREE-LIFT	
⇒S/N B564B03936	13.16
S/N B564B03937⇒	13.17

DESCRIPTION	PAGE NO.
M (continued)	
GLP/GDP 30 TF, RIGHT HAND TWO STAGE FULL FREE-LIFT ⇒S/N B564B03936	13.19
S/N B564B03937⇒	13.20
LEFT HAND THREE STAGE FULL FREE-LIFT	12.16
RIGHT HAND THREE STAGE FULL FREE-LIFT	12.20
TWO STAGE LIMITED FREE-LIFT GLP/GDP 30 TF ⇒S/N B562B-16062	11.12
S/N B562B-16063⇒	11.14
MAIN LIFT THREE STAGE FULL FREE-LIFT	12.8
TWO STAGE FULL FREE-LIFT	13.6
MANIFOLD F2.....	3.58
FE	3.30
XA/HA	2.38
MANIFOLD VALVE T080, T081, T109, AND T110 POWERSHIFT S/N A875B-15438Y⇒ (T081), S/N A875B-15479Y⇒ Includes 15474-15476 (T080).....	9.29
MAST INSTALLATION.....	14.4
MIRROR.....	15.64
MUFFLER AND EXHAUST PIPE	4.38
N	
NOZZLE HOLDER HA.....	2.46
XA.....	2.44
O	
OIL PUMP AND FILTER F2.....	3.60
FE	3.32
HA	2.36
XA.....	2.34
OUTER MAST THREE STAGE FULL FREE-LIFT	12.2
TWO STAGE FULL FREE-LIFT	13.2
TWO STAGE LIMITED FREE-LIFT.....	11.2
P	
PARK BRAKE	8.14
PEDAL LINKAGE GM 3.0L, HYDROSTATIC TRANSMISSION DIRECTIONAL CONTROL LEVER.....	5.96
FORWARD AND REVERSE LEVER	5.98

DESCRIPTION	PAGE NO.
P (continued)	
HA, HYDROSTATIC TRANSMISSION	
DIRECTIONAL CONTROL PEDAL.....	5.90
FORWARD AND REVERSE LEVER	5.94
PUMP	
HYDROSTATIC	9.50
PUMP DRIVE	
T080, T081, T109, AND T110 POWERSHIFT.....	9.36
R	
RADIATOR AND HOSES	
FE/F2	
S/N A875B-22174A⇒	3.18
⇒S/N A875B-7838.....	3.14
S/N A875B-7839⇔S/N A875B-22174A	3.16
HA HYDROSTATIC	2.18
HYDROSTATIC	4.58
POWERSHIFT	
LOW EMISSIONS	4.56
S/N A875B-22174A⇒	4.54
⇒S/N A875B-7838.....	4.50
S/N A875B-7838⇔S/N A875B-22173A	4.52
XA/HA POWERSHIFT	
S/N A875B-22174A⇒	2.16
⇒S/N A875B-7838.....	2.12
S/N A875B-7839⇔S/N A875B-22173A	2.14
REGULATOR	
GM	
S/N A875B-10736⇒ (FE), S/N A875B-10761⇒ (F2), S/N A875B-15397⇒ (GM).....	5.34
S	
SEAT	
FULL SUSPENSION	
⇒D/B 01/2000.....	1.16
SHEET 1 OF 2	
D/B 01/2000⇒	1.18
SHEET 2 OF 2	
D/B 01/2000⇒	1.20
NON-SUSPENSION	
SEARS	1.14
SEMI-SUSPENSION	
⇒D/B 01/2000.....	1.22
SUSPENSION	1.24
SHIFT LEVER	
⇒S/N A875B-10943X.....	7.10
S/N A875B-10944X⇒.....	7.12
SIDE-SHIFT CARRIAGE	
1067 MM.....	15.8
1219 MM.....	15.12

DESCRIPTION	PAGE NO.
-------------	----------

S (continued)

977 MM	15.4
INTEGRAL	
THREE STAGE FULL FREE-LIFT	15.22
TWO STAGE FULL FREE-LIFT	15.20
TWO STAGE LIMITED FREE-LIFT	15.18
SIDE-SHIFT CYLINDER	15.16
INTEGRAL	15.24
SIT TIRE AND WHEEL	
DRIVE WHEEL 28 X 9-15	
GLP/GDP 30 TF, SHEET 2 OF 2	15.34
SOOT TRAP	
XA/HA	2.6
SPOTLIGHT	15.56
STARTER MOTOR	
FE/F2 LPG	
S/N A875B-6004⇒	6.60
⇒S/N A875B-6004	6.58
XA/HA DIESEL	6.62
STEER CYLINDER	
D/B 08/2005⇒	7.22
STEERING COLUMN	
⇒S/N A875B-10943X	7.2
S/N A875B-10944X⇒	7.6
STEERING CYLINDER	
⇒D/B 08/2005	7.20
STEERING HAND PUMP	
⇒S/N A875B-10943X	7.16
S/N A875B-10944X⇒	7.18
STROBE LIGHT	15.44

T

THROTTLE BODY AND LPG MIXER	
3.0L LPG	
LOW EMISSIONS	5.24
THROTTLE LINKAGE	5.70
2.0L AND 2.2L GASOLINE AND LPG	
3.0L, WITH LOW EMISSIONS	5.72
FOOT DIRECTIONAL CONTROL PEDAL	
3.0L, WITH LOW EMISSIONS	5.86
FORWARD AND REVERSE LEVER	
LPG 3.0L, WITH LOW EMISSIONS	5.84
GM 3.0L	
S/N A875B-15397⇒	5.80
⇒S/N A875B-15397	5.76
HA/XA	5.74
POWERSHIFT FOOT DIRECTIONAL CONTROL PEDAL	5.88
TILT CYLINDER	10.48
TIMING GEAR COVER AND OIL SUMP	

DESCRIPTION	PAGE NO.
T (continued)	
F2.....	3.56
FE	3.28
XA/HA	2.32
TIRE AND WHEEL	
DRIVE WHEEL 28 X 9-15	
GLP/GDP 30 TF, SHEET 1 OF 2	15.32
DRIVE WHEEL 7.00 X 12	
GLP/GDP 20-25 RF/TF, SHEET 1 OF 2	15.28
GLP/GDP 20-25 RF/TF, SHEET 2 OF 2	15.30
STEER WHEEL (GDP/GLP 20-25 RF/TF)	
6.00 X 9, 10 PLY	15.36
STEER WHEEL 6.50 X 10	
GLP/GDP 25 RF/TF AND GLP/GDP 30 TF	15.38
TRAIL AXLE ASSEMBLY	7.14
TRANSMISSION	
HYDROSTATIC	
SHEET 1 OF 2	
T080 AND T081 POWERSHIFT	
⇒S/N T80B63835, ⇒S/N T81B09350	9.2
T109 AND T110 POWERSHIFT	9.10
SHEET 2 OF 2	
T080 AND T081 POWERSHIFT	
⇒S/N T80B63835, ⇒S/N T81B09350	9.6
T109 AND T110 POWERSHIFT	9.13
TRANSMISSION COOLING	
HYDROSTATIC	
POWERSHIFT	
2.0L, 2.2L LPG; 2.5L, 3.0L DIESEL	
⇒S/N A875B-19844Z	9.41
S/N A875B-19845Z⇒	9.42
3.0L LPG	
⇒S/N A875B-19844Z	9.44
S/N A875B-19845Z⇒	9.46
U	
UPSWEPT EXHAUST	4.42
XA/HA	2.10
V	
VALVE	
FOUR FUNCTION	
THREE FUNCTION	10.70
THREE FUNCTION	10.66
VALVE ATTACHING PARTS	
FOUR FUNCTION	
⇒S/N A875B-10871	10.58
S/N A875B-10872⇒	10.62
THREE FUNCTION	
⇒S/N A875B-10871	10.50

DESCRIPTION	PAGE NO.
V (continued)	
S/N A875B-10872⇒.....	10.54
W	
WATER PUMP	
F2	
S/N A875B-10761⇒.....	3.72
⇒S/N A875B-10761.....	3.70
FE.....	3.42
XA/HA.....	2.50
WIRE HARNESS	
ALTERNATOR TO ENGINE HARNESS.....	6.66
CAB.....	6.67
CHASSIS	
⇒S/N A875B-05025W.....	6.68
S/N A875B-22174A⇔S/N A875B-23311A.....	6.72
S/N A875B-23312A⇒.....	6.74
S/N A875B-5026W⇔S/N A875B-15396Y.....	6.70
COWL	
EPA COMPLIANT.....	6.94
⇒S/N A875B-10943.....	6.76
S/N A875B-10944⇔S/N A875B-12120Y INC. 13135-13149.....	6.80
S/N A875B-12121Y⇒ EXC. 13135-13149.....	6.82
⇒S/N A875B-15479 INC. 15474-15476.....	6.86
S/N A875B-15479Y⇒ INC. 15474-15476.....	6.90
ENGINE FE/F2 LPG	
S/N A875B-10736X⇒ (FE), S/N A875B-10761X⇒ (F2).....	6.99
⇒S/N A875B-3165.....	6.96
S/N A875B-3166⇒.....	6.98
ENGINE GM 3.0L LPG	
WITH MSTs	
D/B 08/2002⇒.....	6.116
⇒S/N A875B-4059.....	6.110
S/N A875B-4060⇔D/B 08/2002.....	6.112
WITH THROTTLE-UP.....	6.120
WITHOUT MSTs	
D/B 08/2002⇒.....	6.108
⇒S/N A875B-15396Y.....	6.104
S/N A875B-15397Y⇔D/B 08/2002 -01.....	6.106
ENGINE SHUTDOWN SYSTEM.....	6.122
ENGINE XA/HA DIESEL.....	6.126
WITH THROTTLE-UP.....	6.124
HYDROSTATIC TRANSMISSION	
⇒S/N A875B-15478 EXC. 15474-15476.....	6.128
S/N A875B-15479⇒ INC. 15174-15176.....	6.130
INSTRUMENT CLUSTER.....	6.132
NEUTRAL START.....	6.134
THREE-WAY CATALYTIC CONVERTER	
⇒S/N A875B-12120 INC. 13136-13149.....	6.64

DESCRIPTION	PAGE NO.
-------------	----------

W (continued)

WIRE HARNESS (MAIN)	
ENGINE GM 3.0L LPG	
SHEET 1 OF 2	6.100
SHEET 2 OF 2	6.102

**SECTION 1
GENERAL TRUCK**

DESCRIPTION	PAGE
CAB	
BLACK PVC WITH STEEL FRONT	1.30
STEEL.....	1.26
COUNTERWEIGHT	1.12
FRAME AND FLOORPLATES.....	1.2
HEATER ASSEMBLY	
2.0L, 2.2L GLP, 2.5L, AND 3.0L DIESEL	1.32
3.0L GLP.....	1.34
HOOD AND SIDE DOORS.....	1.6
HOOD LINER	1.10
LABELS.....	1.37
LOW NOISE	1.40
SEAT	
FULL SUSPENSION	
⇒D/B 01/2000.....	1.16
SHEET 1 OF 2	
D/B 01/2000⇒	1.18
SHEET 2 OF 2	
D/B 01/2000⇒	1.20
NON-SUSPENSION	
SEARS	1.14
SEMI-SUSPENSION	
⇒D/B 01/2000.....	1.22
SUSPENSION	1.24

FRAME AND FLOORPLATES

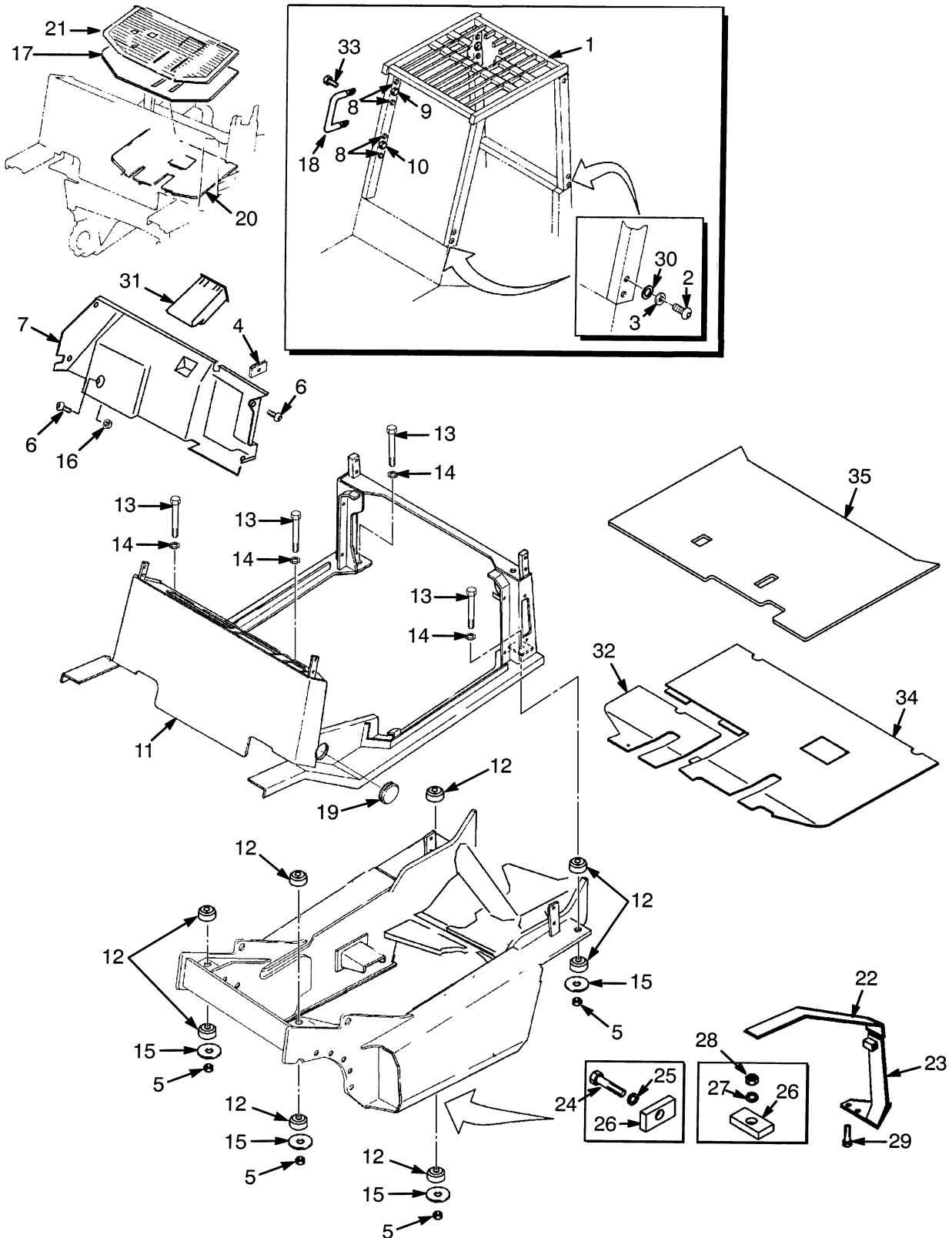

YP260518



FRAME AND FLOORPLATES

ITEM	PART NO.	DESCRIPTION	QTY
1	505968580	Overhead Guard (Raised Height).....	1
1	505974518	Overhead Guard (Standard).....	1
2	504262755	Capscrew.....	8
3	904310409	Washer.....	8
4	505972586	Nut (Foldover).....	4
5	520053804	Nut.....	4
6	505970553	Capscrew.....	5
7	cf 504240966	Cover.....	1
7	bf 524138905	Cover.....	1
7	cg 524141550	Cover.....	1
7	bg 524141551	Cover.....	1
8	504241782	Plug.....	12
9	504241783	Plug.....	5
10	504241784	Plug.....	4
11	f 504240727	Frame.....	1
11	g 524141542	Frame.....	1
11	e 524145357	Frame.....	1
12	580011994	Mount (Set of 2).....	4
13	931006914	Capscrew.....	4
14	449021010	Washer.....	4
15	580044531	Washer.....	4
16	505970579	Nut.....	2
17	504315706	Sound Liner.....	1
18	900001242	Handle.....	1
19	505972576	Plug.....	2
20	c 504240766	Floorplate.....	1
20	c 504241791	Floorplate (Low Noise) (Without Cab).....	1
21	c 504240787	Floor Mat (Low Noise).....	1
21	c 504240990	Floor Mat.....	1
22	a 505973529	Fender (RH) (Upper).....	1
22	d 505973563	Fender (RH) (Upper).....	1
22	d 505973576	Fender (LH) (Upper).....	1
22	a 505973595	Fender (LH) (Upper).....	1
23	a 505973505	Fender (LH) (Lower).....	1
23	a 505973508	Fender (RH) (Lower).....	1
23	d 505973509	Fender (RH) (Lower).....	1
23	d 505973598	Fender (LH) (Lower).....	1
24	449001302	Capscrew.....	8
25	449022013	Lockwasher.....	12
26	900001254	Bar.....	12
27	504071785	Washer.....	4
28	449015044	Nut.....	4
29	449001015	Capscrew.....	4
30	504262754	Washer.....	8
31	c 520036895	Storage Compartment.....	1
32	b 524139616	Floorplate (RH).....	1
33	504060774	Screw.....	2
34	b 504315702	Floorplate.....	1
34	b 504315705	Floorplate (Low Noise Option).....	1
35	b 504315708	Floor Mat.....	1

FRAME AND FLOORPLATES

ITEM	PART NO.	DESCRIPTION	QTY
35	b 504315736	Floor Mat (Low Noise)	1
36	524205044	Plate (Seat Mounting) (Not Illustrated)	1
37	449001014	Capscrew (Not Illustrated)	4

FOOTNOTES:

- a** Dual
- b** Foot Directional Control Pedal
- c** Forward and Reverse Lever
- d** Wide
- e** S/N A875B-10736X ⇒ GM 3.0L
- f** ⇒ S/N A875B-10943
- g** S/N A875B-10944 ⇒

HOOD AND SIDE DOORS

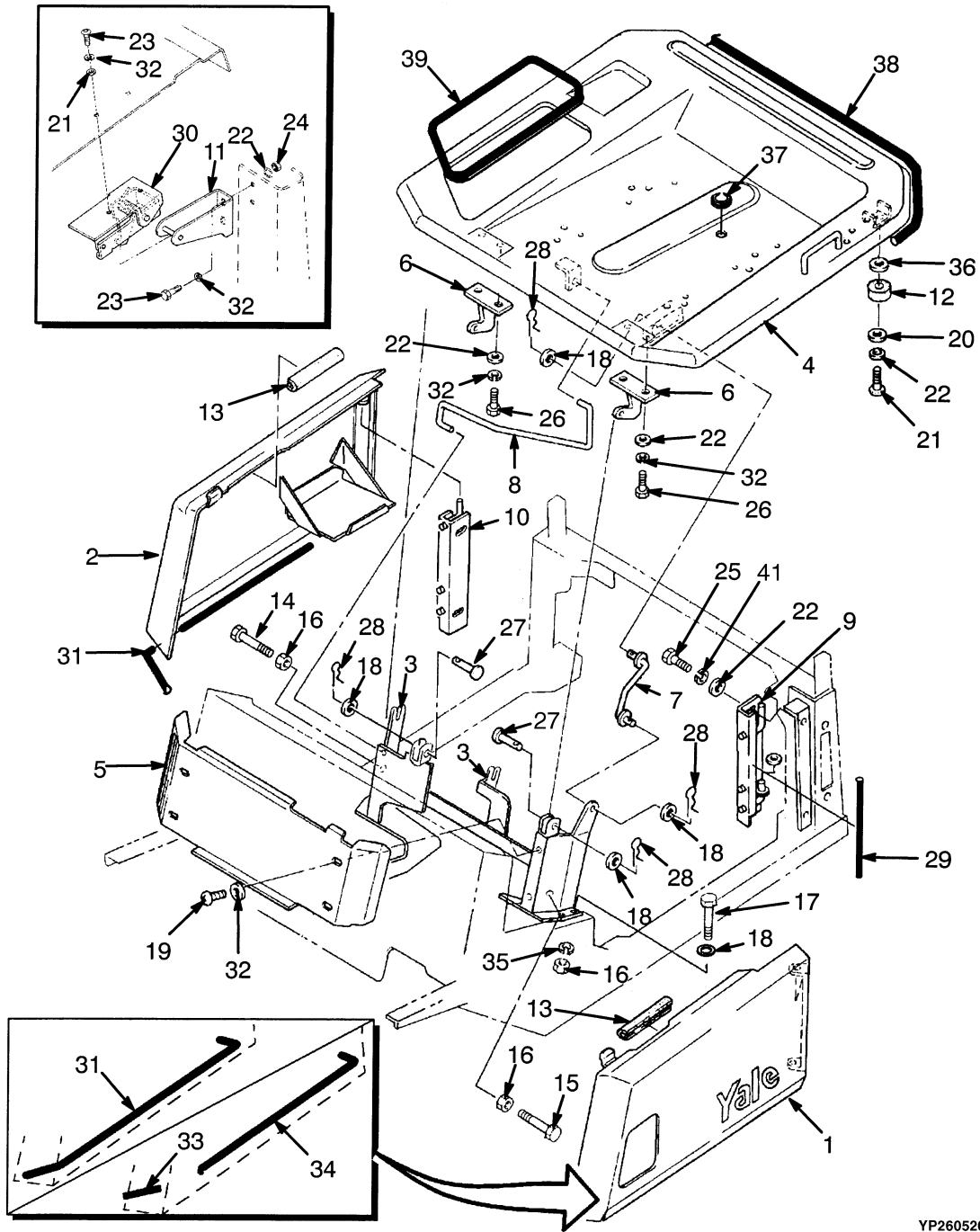

YP260520



HOOD AND SIDE DOORS

ITEM	PART NO.	DESCRIPTION	QTY
1	504240979	Door (LH).....	1
1	504240980	Door (LH) (GLP 20/25/30 RF)	1
2	504240985	Door (RH)	1
3	505972577	Support.....	1
4	a 908594716	Cover	1
4	b 908594741	Cover	1
4	c 908594742	Cover	1
4	258743244	Cover (With Cab) (Rubber Mat).....	1
5	909835611	Plate	1
6	504240757	Hinge	2
7	922134300	Support.....	1
8	b 504281774	Spring	1
8	a 920546403	Spring	1
8	504281773	Spring (With Suspension Seat)	1
9	504240856	Hinge (LH)	1
10	504240857	Hinge (RH).....	1
11	923533400	Hook Assembly.....	1
12	917426300	Cushion (Rubber)	2
13	912291312	Trim.....	2
14	505974549	Capscrew.....	1
15	449001029	Capscrew.....	1
16	449015044	Nut.....	6
17	449001302	Capscrew.....	4
18	449021006	Washer	AR
19	501729905	Capscrew.....	4
20	449021001	Washer	2
21	580032373	Capscrew.....	4
22	449022016	Lockwasher	14
23	449001014	Capscrew.....	2
24	449015014	Nut.....	2
25	449001415	Capscrew.....	4
26	449001013	Capscrew.....	4
27	912326300	Pin	2
28	965801908	Cotter Pin	4
29	916748304	Seal	2
30	923534400	Arm Assembly (Hood Latch)	1
31	916748303	Seal (RH) (GDP 20/25/30 TF)	1
31	916748303	Seal	2
32	504226242	Washer	14
32	023604600	Washer (Optional)	14
33	916748327	Seal (LH) (GDP 20/25/30 TF).....	1
34	916748308	Seal (LH) (GDP 20/25/30 TF).....	1
35	449022013	Lockwasher	4
36	502398907	Washer	AR
37	014195600	Grommet.....	1
38	923179401	Strip (Hood)	1
39	923179404	Strip (Hood)	1

HOOD AND SIDE DOORS

ITEM	PART NO.	DESCRIPTION	QTY
40	502566904	Washer (Optional)	1
41	520037852	Washer	4

FOOTNOTES:

- a** ⇒ S/N A875B-10334
- b** S/N A875B-10335⇒S/N A875B-15090Y
- c** S/N A875B-15091Y ⇒

HOOD LINER

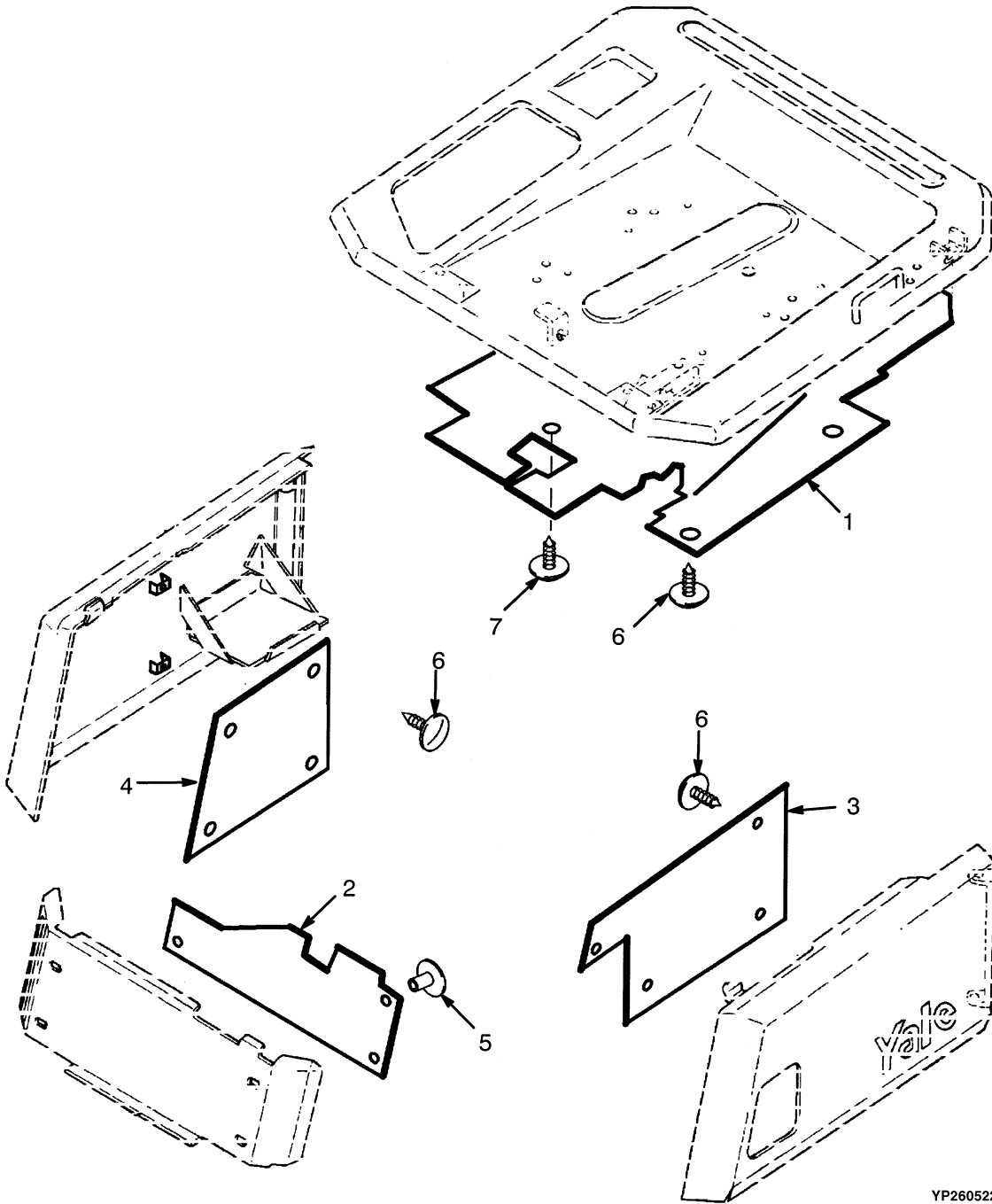

YP260522



Suggest:

For more complete manuals. Please go to the home page.

<https://www.ebooklibonline.com>

If the above button click is invalid. Please download this document first, and then click the above link to download the complete manual.

Thank you so much for reading

ITEM	PART NO.	DESCRIPTION	QTY
1	504241701	Liner (Hood).....	1
2	504246763	Liner (Front Cover)	1
3	504241724	Liner (LH Door).....	1
4	504241725	Liner (RH Door)	1
5	900003273	Button	3
6	518793609	Fastener	14
7	580001090	Fastener	1

COUNTERWEIGHT

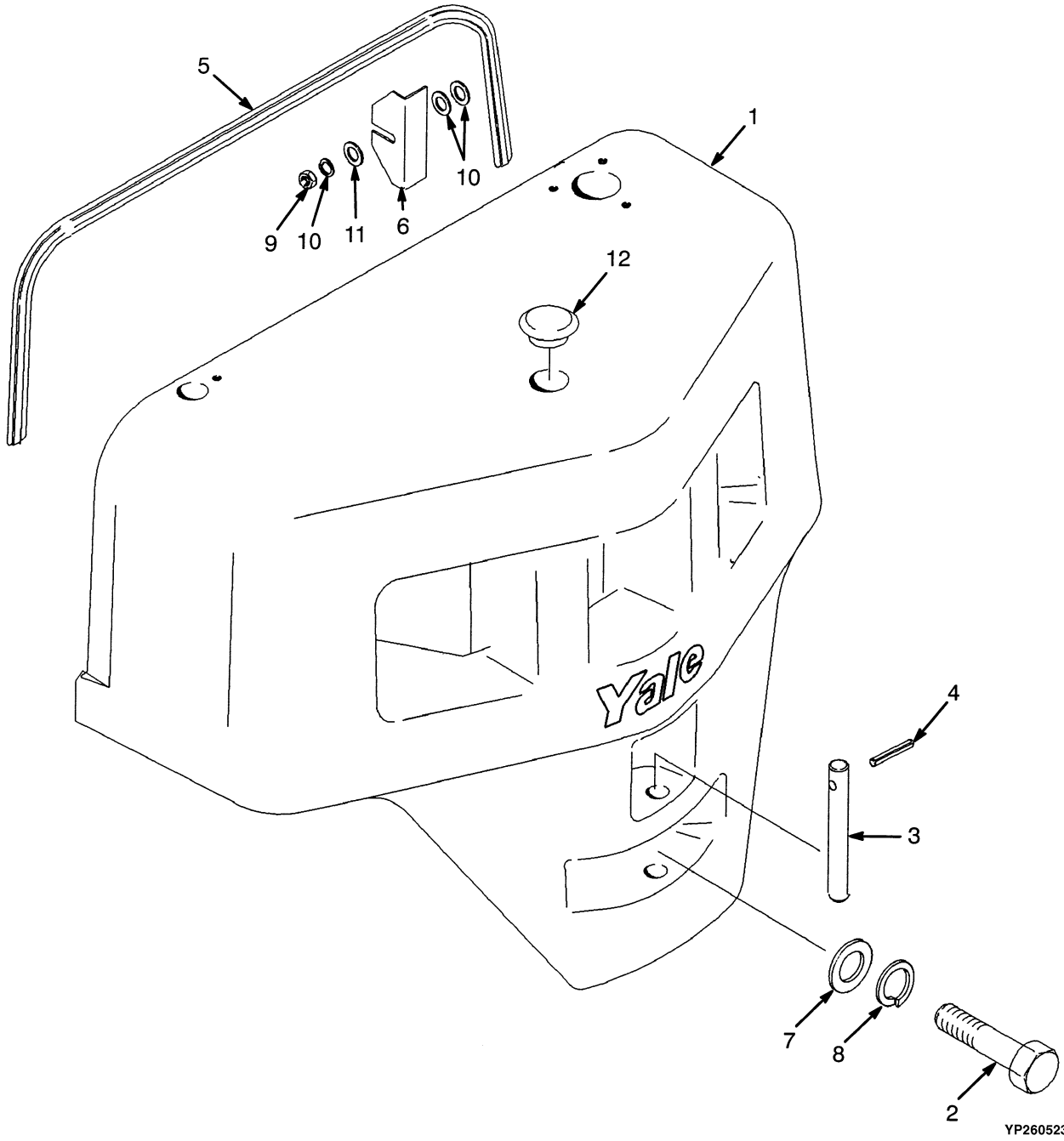

YP260523

<https://www.ebooklibonline.com>

Hello dear friend!

Thank you very much for reading.

Enter the link into your browser.

The full manual is available for immediate download.

<https://www.ebooklibonline.com>