

Yale

PARTS MANUAL

GDP 040 RG, GDP 050 RG (A875)



YP990083

Yale

SECTIONS

1	GENERAL TRUCK
2	ENGINE ASSEMBLY
3	EXHAUST SYSTEM
4	COOLING SYSTEM
5	FUEL SYSTEM
6	ELECTRICAL SYSTEM
7	TRANSMISSION
8	DRIVE AXLE
9	STEERING SYSTEM
10	BRAKE SYSTEM
11	HYDRAULIC SYSTEM
12	LIFTING MECHANISM
13	ATTACHMENTS AND HEADER HOSE GROUP
14	OPTIONS
15	FIELD CONVERSION KITS
16	NUMERICAL INDEX

ALPHABETICAL INDEX

DESCRIPTION	PAGE NO.
A	
ABBREVIATIONS QUICK REFERENCE SHEET	vii
AIR CLEANER AND MOUNTING	
⇒S/N A875B-13057	5-10
S/N A875B-13058⇒	5-12
ALPHABETICAL INDEX.....	i
ALTERNATOR	6-4
TYPE GS, LPS, AND DS.....	6-6
AMBER FLASHING BEACON.....	14-6
AUDIBLE ALARM.....	14-16
AUDIBLE ALARM CONVERSION KITS.....	15-2
B	
BRAKE	10-2
BRAKE LINES.....	10-10
BRAKE PEDAL LINKAGE	10-8
C	
CAMSHAFT AND VALVES.....	2-6
CARRIAGE	
THREE STAGE FULL FREE-LIFT	12-38
TWO STAGE FULL FREE-LIFT	12-54
TWO STAGE LIMITED FREE-LIFT.....	12-14
CONTROL VALVE	
⇒S/N A875B-2678W	7-8
S/N A875B-2679W⇒	7-12
CONTROL VALVE CONVERSION KITS.....	15-3
COUNTERWEIGHT	1-12
CRANKSHAFT AND PISTONS.....	2-8
CYLINDER BLOCK	2-2
CYLINDER HEAD	2-4
D	
DIFFERENTIAL	
D/B 07/1998⇒	7-26
⇒D/B 07/1998	7-22
DIRECTIONAL CONTROL PEDAL	5-18
DIRECTIONAL CONTROL PEDAL LINKAGE.....	5-16
DRIVE AXLE	8-2
DRIVE TIRE AND FENDER CONVERSION KITS.....	15-2
E	
ELECTRICAL	6-10
COWL	6-16
ENGINE	6-2
TYPE DS.....	6-14
ENGINE MOUNT.....	2-16

<https://www.ebooklibonline.com>

Hello dear friend!

Thank you very much for reading.

Enter the link into your browser.

The full manual is available for immediate download.

<https://www.ebooklibonline.com>

GENERAL INFORMATION

DESCRIPTION	PAGE NO.
-------------	----------

E (continued)

ENGINE SHUTDOWN SYSTEM.....	6-12
EXHAUST	
VERTICAL	3-6

F

FIRE EXTINGUISHER	14-18
FLYWHEEL AND TORQUE CONVERTER	2-14
FORKS	
GDP 040 RG.....	1-20
GDP 045 RG.....	1-21
GDP 050 RG.....	1-22
FORWARD AND REVERSE CLUTCH	
⇒S/N T080M-04189	7-16
S/N T080M-04190⇔S/N T080M-04775	7-18
S/N T080M-04776⇒.....	7-20
FRAME AND FLOORPLATES.....	1-4
FREE LIFT	
THREE STAGE FULL FREE-LIFT	12-26
FREE-LIFT	
TWO STAGE FULL FREE-LIFT	12-46
FREE-LIFT CYLINDER	
THREE STAGE FULL FREE-LIFT	
SHEET 1 OF 2	12-34
SHEET 2 OF 2	12-36
TWO STAGE FULL FREE-LIFT	12-52
FUEL	5-2
FUEL SYSTEM	
DIESEL	5-8

G

GENERAL TRUCK	1-2
---------------------	-----

H

HOOD.....	1-8
HOOD LINER	1-10
HOSE TAKE-UP	
THREE STAGE FULL FREE-LIFT	13-22
TWO STAGE FULL FREE-LIFT	13-26
TWO STAGE LIMITED FREE-LIFT.....	13-18
HOSE TAKE-UP CONVERSION KITS THREE STAGE FULL FREE-LIFT	15-5
HOSE TAKE-UP CONVERSION KITS TWO STAGE FULL FREE-LIFT	15-7
HOSE TAKE-UP CONVERSION KITS TWO STAGE LIMITED FREE-LIFT.....	15-4
HOW TO FIND THE DESIRED PART NUMBER.....	ix
HOW TO USE THE ILLUSTRATED PARTS MANUAL	ix
HYDRAULIC PUMP	
DOUBLE GEAR	
⇒S/N A875B-11245.....	11-18
S/N A875B-11246⇒.....	11-20

DESCRIPTION	PAGE NO.
H (continued)	
SINGLE GEAR	
⇒S/N A875B-5462.....	11-14
S/N A875B-5463⇒.....	11-16
HYDRAULICS	
⇒S/N A875B-10871	11-2
S/N A875B-10872↔S/N A875B-10943	11-6
S/N A875B-10944⇒	11-10
I	
IDENTIFICATION OF ATTACHMENT AND SIDE-SHIFT CARRIAGE SERIAL NUMBERS.....	xii
IDENTIFICATION OF MAST SERIAL NUMBER.....	xi
IDENTIFICATION OF TRUCK SERIAL NUMBER.....	x
INJECTION PUMPS.....	5-6
INNER MAST	
THREE STAGE FULL FREE-LIFT	12-20
TWO STAGE FULL FREE-LIFT	12-42
TWO STAGE LIMITED FREE-LIFT.....	12-4
INSTRUMENT CLUSTER	6-38
INTERMEDIATE MAST	
THREE STAGE FULL FREE-LIFT	12-18
L	
LABEL AND PLATE LOCATION.....	1-15
LIFT	
TWO STAGE LIMITED FREE-LIFT.....	12-6
LIFT CYLINDER	
TWO STAGE LIMITED FREE-LIFT.....	12-10
LIFTING EYES	14-2
LIGHT CONVERSION KITS.....	15-2
LIGHTS.....	14-14
DRIVE, TURN, AND SIDE	14-8
LOAD BACKREST WELDMENT	1-18
LOW NOISE	1-34
M	
MAIN CYLINDER	
LEFT HAND	
TWO STAGE FULL FREE-LIFT	
S/N PENDING PER ECN 73680⇒.....	12-49
⇒S/N PENDING PER ECN 73680.....	12-48
RIGHT HAND	
TWO STAGE FULL FREE-LIFT	
S/N PENDING PER ECN 73680⇒.....	12-51
⇒S/N PENDING PER ECN 73680.....	12-50
THREE STAGE FULL FREE-LIFT	12-30
MAIN LIFT	
THREE STAGE FULL FREE-LIFT	12-22
TWO STAGE FULL FREE-LIFT	12-44

GENERAL INFORMATION

DESCRIPTION	PAGE NO.
M (continued)	
MANIFOLD VALVE	
S/N A875B-15479Y⇒ INC. 15474-15476.....	7-15
MANIFOLDS.....	3-2
MAST INSTALLATION.....	11-26
MAST TILT CONVERSION KITS	15-3
MASTER CYLINDER	10-6
MASTER PART SHEET CROSS-REFERENCE	xiv
MIRROR CONVERSION KITS.....	15-3
MUFFLER AND EXHAUST PIPES.....	3-4
N	
NOZZLE HOLDER	5-4
O	
OIL PAN AND TIMING GEAR COVER.....	2-10
OIL PUMP AND FILTER.....	2-12
OUTER MAST	
THREE STAGE FULL FREE-LIFT	12-16
TWO STAGE FULL FREE-LIFT	12-40
TWO STAGE LIMITED FREE-LIFT.....	12-2
P	
PARKING BRAKE LEVER.....	10-4
PUMP DRIVE	7-28
R	
RADIATOR AND HOSES	
⇒S/N A875B-7837	4-4
S/N A875B-7838↔S/N PENDING PER ECN 95530-01.....	4-6
S/N PENDING PER ECN 95530-01⇒.....	4-8
RADIATOR CONVERSION KITS	15-3
ROTATING BEACON.....	14-4
S	
SEAT	
FULL SUSPENSION	
SHEET 1 OF 2	
S/N A875B-12161⇒	1-26
SHEET 2 OF 2	
S/N A875B-12161⇒	1-28
NON-SUSPENSION.....	1-32
SEMI SUSPENSION	
⇒S/N A875B-12161.....	1-24
SUSPENSION WITH HIP RESTRAINT.....	1-30
SHIFT LINKAGE	
⇒S/N A875B-10943X.....	9-8
S/N A875B-10944X⇒.....	9-10

DESCRIPTION	PAGE NO.
S (continued)	
SIDE-SHIFT CARRIAGE.....	13-2
INTEGRAL	
THREE STAGE FULL FREE-LIFT	13-12
TWO STAGE FULL FREE-LIFT	13-10
TWO STAGE LIMITED FREE-LIFT	13-8
SIDE-SHIFT CYLINDER	13-6
INTEGRAL.....	13-14
SIDE-SHIFT HYDRAULIC HOSES	
INTEGRAL	
TWO AND THREE STAGE FULL FREE-LIFT.....	13-17
TWO STAGE LIMITED FREE-LIFT	13-16
STARTER	6-8
STEERING AXLE.....	9-12
STEERING CONTROL UNIT	
⇒S/N A875B-10943	9-16
S/N A875B-10944⇒.....	9-18
STEERING CYLINDER.....	9-20
STEERING POD	
⇒S/N A875B-10943	9-2
S/N A875B-10944⇒.....	9-4
STROBE LIGHT	14-12
T	
THROTTLE LINKAGE	5-14
TILT CYLINDER	11-24
TRANSMISSION	
1 OF 2.....	7-2
2 OF 2.....	7-6
TRANSMISSION COOLING	
⇒S/N A875B-19844Z	7-30
S/N A875B-19845Z⇒.....	7-32
TUBE EXTENSION CONVERSION KITS TWO AND THREE STAGE FULL FREE-LIFT	15-3
TUBE EXTENSION CONVERSION KITS TWO STAGE LIMITED FREE-LIFT.....	15-3
V	
VALVE	
CONTROL	
FOUR FUNCTION.....	11-48
THREE FUNCTION.....	11-44
FLOW.....	11-22
VALVE ATTACHING PARTS	
FOUR FUNCTION	
⇒S/N A875B-10871	11-36
S/N A875B-10872⇒.....	11-40
THREE FUNCTION	
⇒S/N A875B-10871	11-28
S/N A875B-10872⇒.....	11-32

GENERAL INFORMATION

DESCRIPTION	PAGE NO.
W	
WATER PUMP.....	4-2
WHEEL AND TIRE	
DRIVE WHEEL	8-6
STEER WHEEL	9-14
WIRE HARNESS	
CHASSIS	
D/B 08/1999⇒.....	6-28
⇒D/B 08/1999.....	6-26
S/N A875B-15397Y⇔S/N PENDING PER ECN 95330-01.....	6-30
S/N PENDING PER ECN 95530-01⇒	6-32
COWL	
⇒S/N A875B-10943.....	6-20
S/N A875B-10944⇒.....	6-24
ENGINE	6-34
ENGINE SHUTDOWN SYSTEM	6-36
INSTRUMENT CLUSTER.....	6-18

**SECTION 1
GENERAL TRUCK**

DESCRIPTION	PAGE
COUNTERWEIGHT	1-12
FORKS	
GDP 040 RG	1-20
GDP 045 RG	1-21
GDP 050 RG	1-22
FRAME AND FLOORPLATES	1-4
GENERAL TRUCK	1-2
HOOD	1-8
HOOD LINER	1-10
LABEL AND PLATE LOCATION	1-15
LOAD BACKREST WELDMENT	1-18
LOW NOISE	1-34
SEAT	
FULL SUSPENSION	
SHEET 1 OF 2	
S/N A875B-12161⇒	1-26
SHEET 2 OF 2	
S/N A875B-12161⇒	1-28
NON-SUSPENSION	1-32
SEMI SUSPENSION	
⇒S/N A875B-12161	1-24
SUSPENSION WITH HIP RESTRAINT	1-30

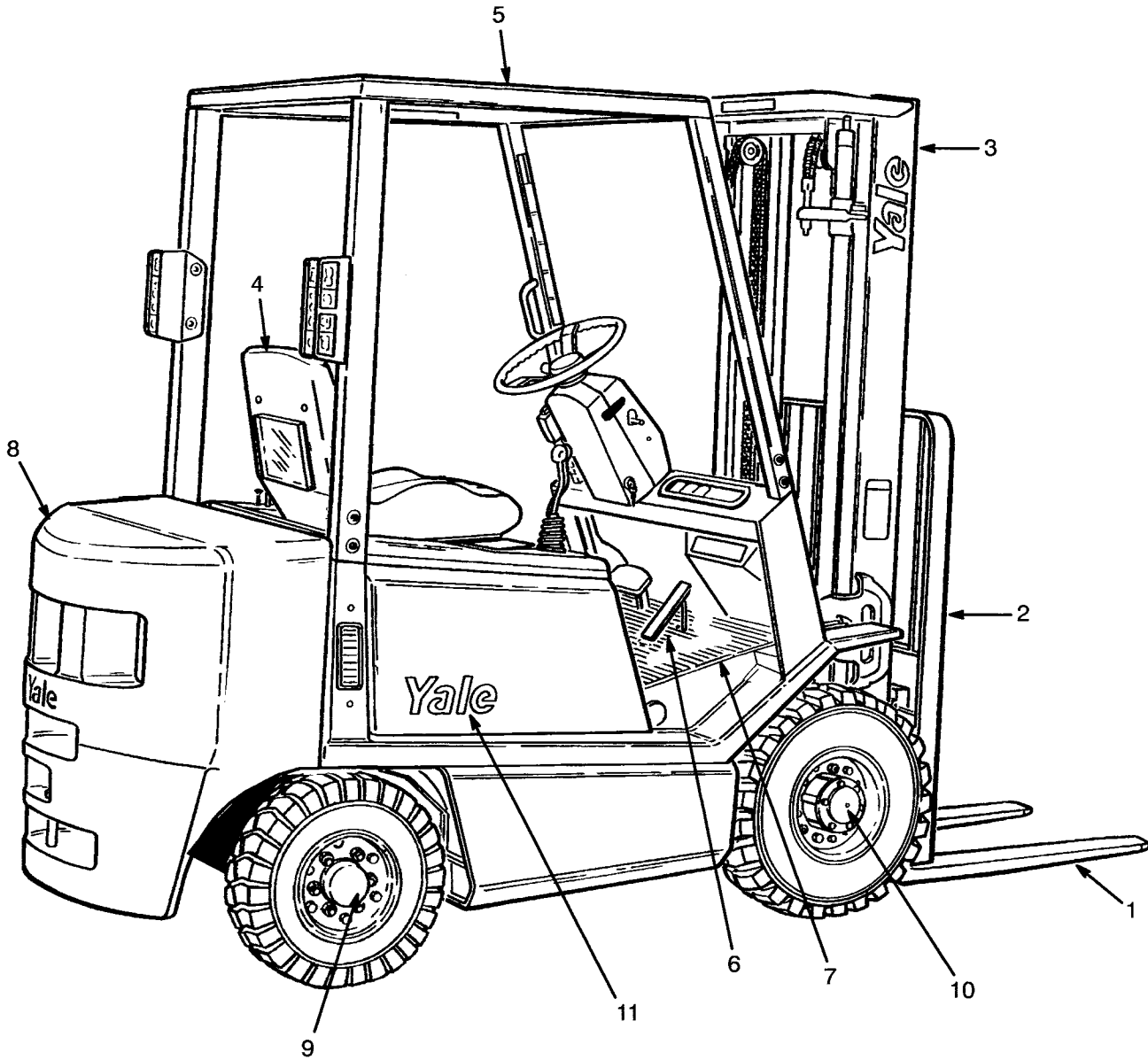

YP260585

ITEM	PART NO.	DESCRIPTION	QTY
1	Load Fork (☞ P10935, P10232)	2
2	Load Backrest (☞ P10219)	1
3	Mast-Two Stage Limited Free-Lift (☞ P10192)	1
3	Mast-Two Stage Full Free-Lift (☞ P10166)	1
3	Mast-Three Stage Full Free-Lift (☞ P10173)	1
4	Seat (Operator) (☞ P10800, P10026)	1
5	Overhead Guard (☞ P10212)	1
6	Accelerator Pedal (☞ P10485)	1
7	Floorplates and Cowl (☞ P10212)	1
8	Counterweight (☞ P10215)	1
9	Steer Axle (☞ P10803)	1
10	Drive Axle Assembly (☞ P10250)	1
11	Label and Plate Location (☞ P10298)	AR

FRAME AND FLOORPLATES

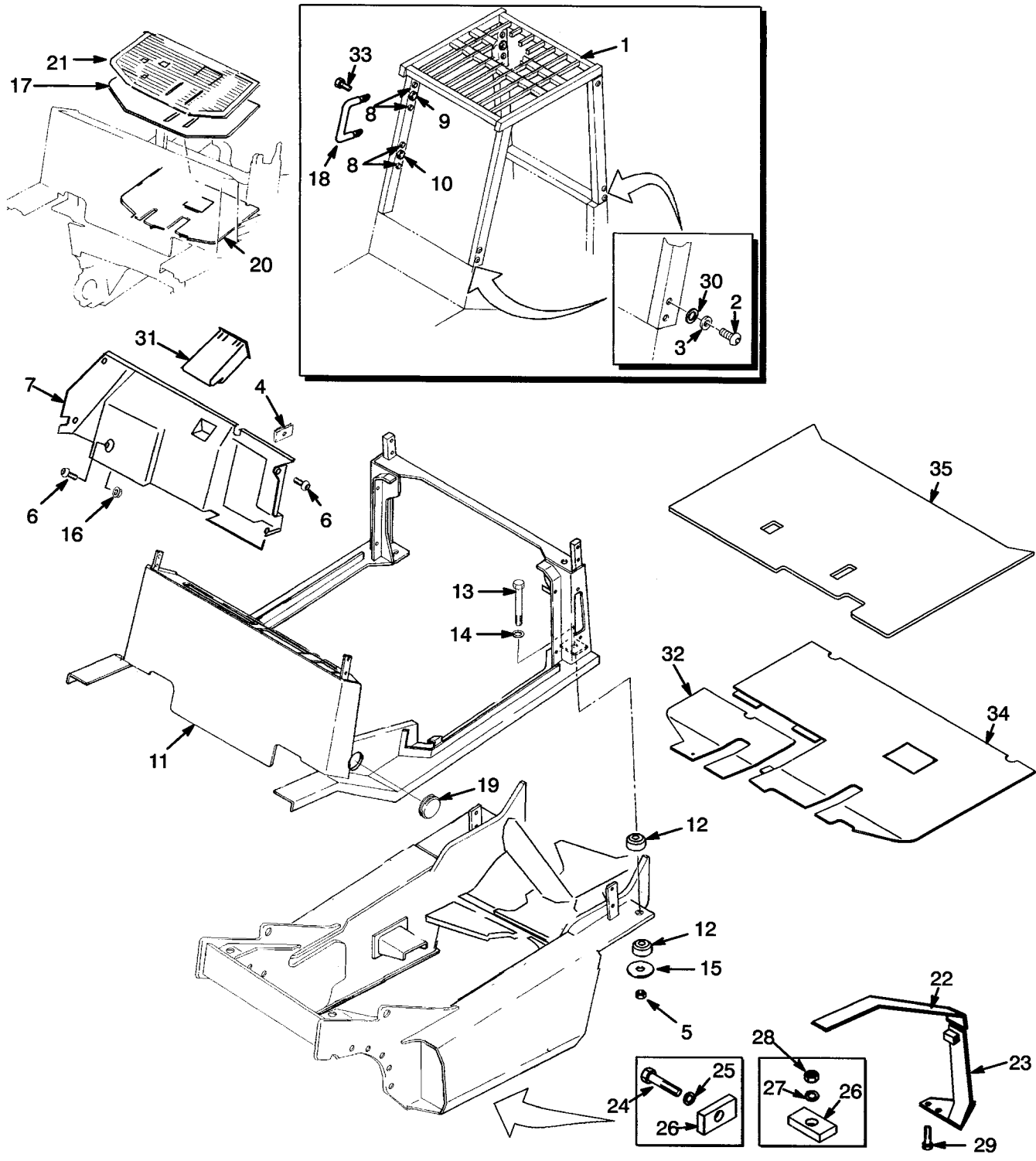

YP260460

FRAME AND FLOORPLATES

ITEM	PART NO.	DESCRIPTION	QTY
1	505974518	Overhead Guard (Standard).....	1
1	505968580	Overhead Guard (Raised)	1
2	504262755	Capscrew.....	8
3	904310409	Washer	8
4	505972586	Nut.....	4
5	520053804	Nut.....	4
6	505970553	Capscrew.....	6
7	ad 524141551	Cover	1
7	bc 504240966	Cover	1
7	bd 524141550	Cover	1
7	ac 524138905	Cover	1
8	504241782	Plug	12
9	504241783	Plug	5
10	504241784	Plug	4
11	c 504240727	Frame	1
11	d 524141542	Frame	1
12	e 520045006	Mount	4
12	f 580011994	Mount	4
13	931006914	Capscrew.....	4
14	449021010	Washer	4
15	505966562	Washer	4
16	505970579	Nut.....	2
17	504315706	Sound Liner	1
18	900001242	Handle	1
19	505972576	Plug	2
20	b 504241791	Floorplate (Low Noise)	1
20	b 504240766	Floorplate	1
21	b 504240787	Floor Mat (Low Noise)	1
21	b 504240990	Floor Mat	1
22	505973529	Fender (RH) (Dual Tire).....	1
22	505973576	Fender (LH) (Wide Tire)	1
22	505973563	Fender (RH) (Wide Tire).....	1
22	505973595	Fender (LH) (Dual Tire)	1
23	505973505	Fender (LH) (Dual Tire)	1
23	505973508	Fender (RH) (Dual Tire).....	1
23	505973509	Fender (RH) (Wide Tire).....	1
23	505973598	Fender (LH) (Wide Tire)	1
24	449001302	Capscrew.....	8
25	449022013	Lockwasher	12
26	900001254	Bar	12
27	504071785	Washer	4
28	449015044	Nut.....	4
29	449001015	Capscrew.....	4
30	504262754	Washer	8
31	b 520036895	Storage Compartment.....	1
32	a 524139616	Floorplate (RH).....	1
33	504060774	Screw.....	2
34	a 504315705	Floorplate (Low Noise)	1
34	a 504315702	Floorplate	1



FRAME AND FLOORPLATES

ITEM	PART NO.	DESCRIPTION	QTY
35	a 504315736	Floor Mat (Low Noise)	1
35	a 501315708	Floor Mat	1

FOOTNOTES:

- a Foot Directional Control Pedal
- b Forward and Reverse Shift Lever
- c ⇒ S/N A875B-10943
- d S/N A875B-10944 ⇒
- e ⇒ S/N PENDING PER ECN 95305
- f S/N PENDING PER ECN 95305 ⇒

HOOD

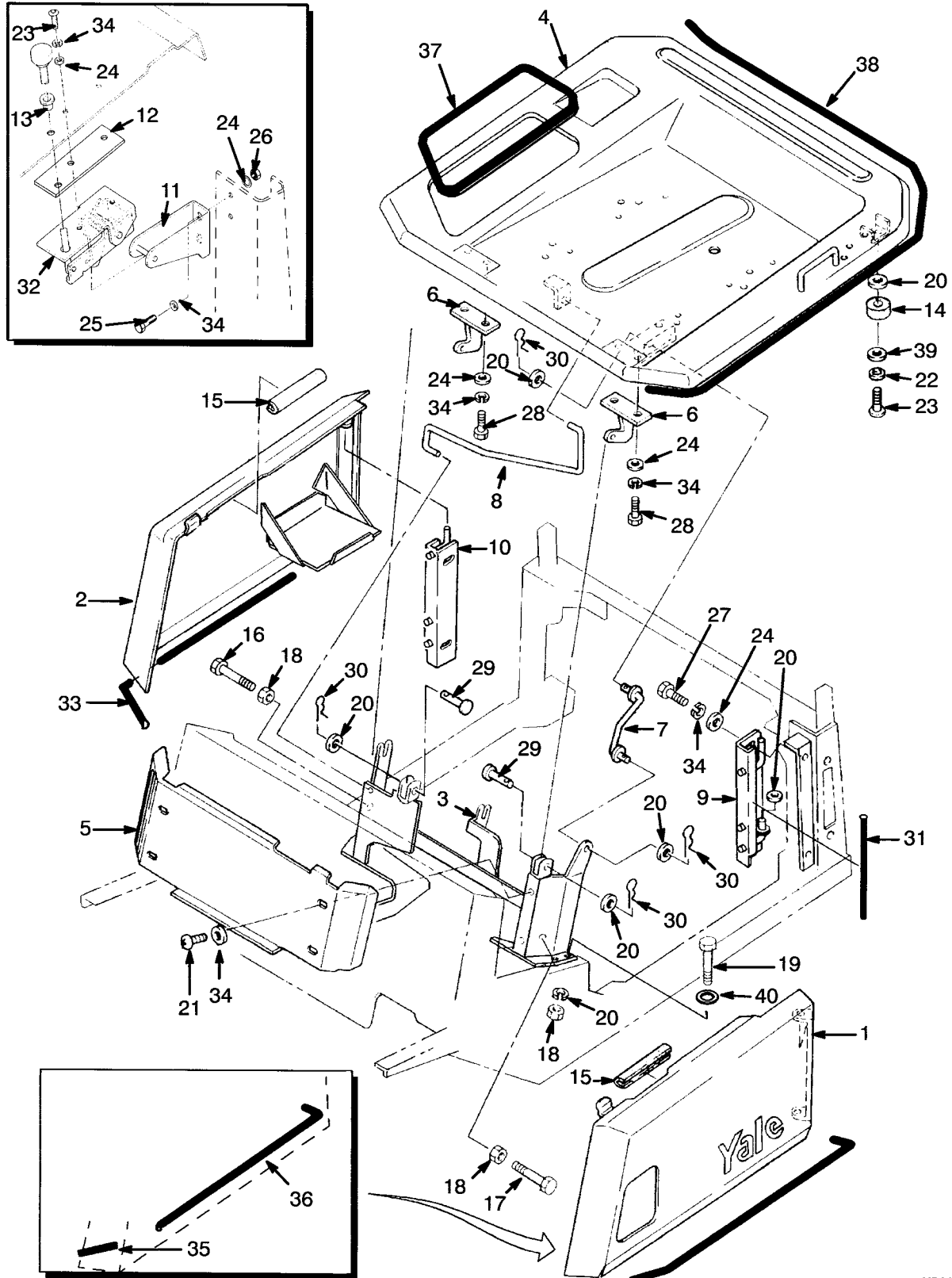

YP260633

ITEM	PART NO.	DESCRIPTION	QTY
1	504240979	Door (LH).....	1
2	504240985	Door (RH).....	1
3	505972577	Support.....	1
4	b 908594741	Cover.....	1
4	a 908594716	Cover.....	1
4	504241701	Liner (Low Noise).....	1
5	909835611	Plate.....	1
5	504246763	Liner (Low Noise).....	1
6	916622300	Hinge.....	2
7	922134300	Support.....	1
8	a 920546403	Spring.....	1
8	b 504281774	Spring.....	1
9	504240856	Hinge (LH).....	1
10	504240857	Hinge (RH).....	1
11	911888602	Striker Plate.....	1
12	922134300	Support.....	1
13	912630304	Bushing.....	1
14	917426300	Cushion (Rubber).....	2
15	912291310	Trim.....	2
16	505974549	Capscrew.....	1
17	449001029	Capscrew.....	1
18	449015044	Nut.....	6
19	449001302	Capscrew.....	4
20	449021006	Washer.....	AR
21	505959528	Capscrew.....	4
22	449021001	Washer.....	2
23	932729907	Capscrew.....	4
24	449022016	Lockwasher.....	14
25	449001014	Capscrew.....	2
26	449015014	Nut.....	2
27	449001415	Capscrew.....	4
28	449001013	Capscrew.....	4
29	912326300	Pin.....	2
30	965801908	Cotter Pin.....	4
31	916748304	Seal.....	2
32	911888601	Arm.....	1
33	916748303	Seal.....	1
34	504226242	Washer.....	18
35	916748327	Seal.....	1
36	916748308	Seal.....	1
37	923179401	Strip.....	1
38	923179404	Strip.....	1
39	449022013	Lockwasher.....	4
40	502398907	Washer.....	AR

FOOTNOTES:

a ⇒ S/N A875B-13334

b S/N A875B-13335 ⇒

HOOD LINER

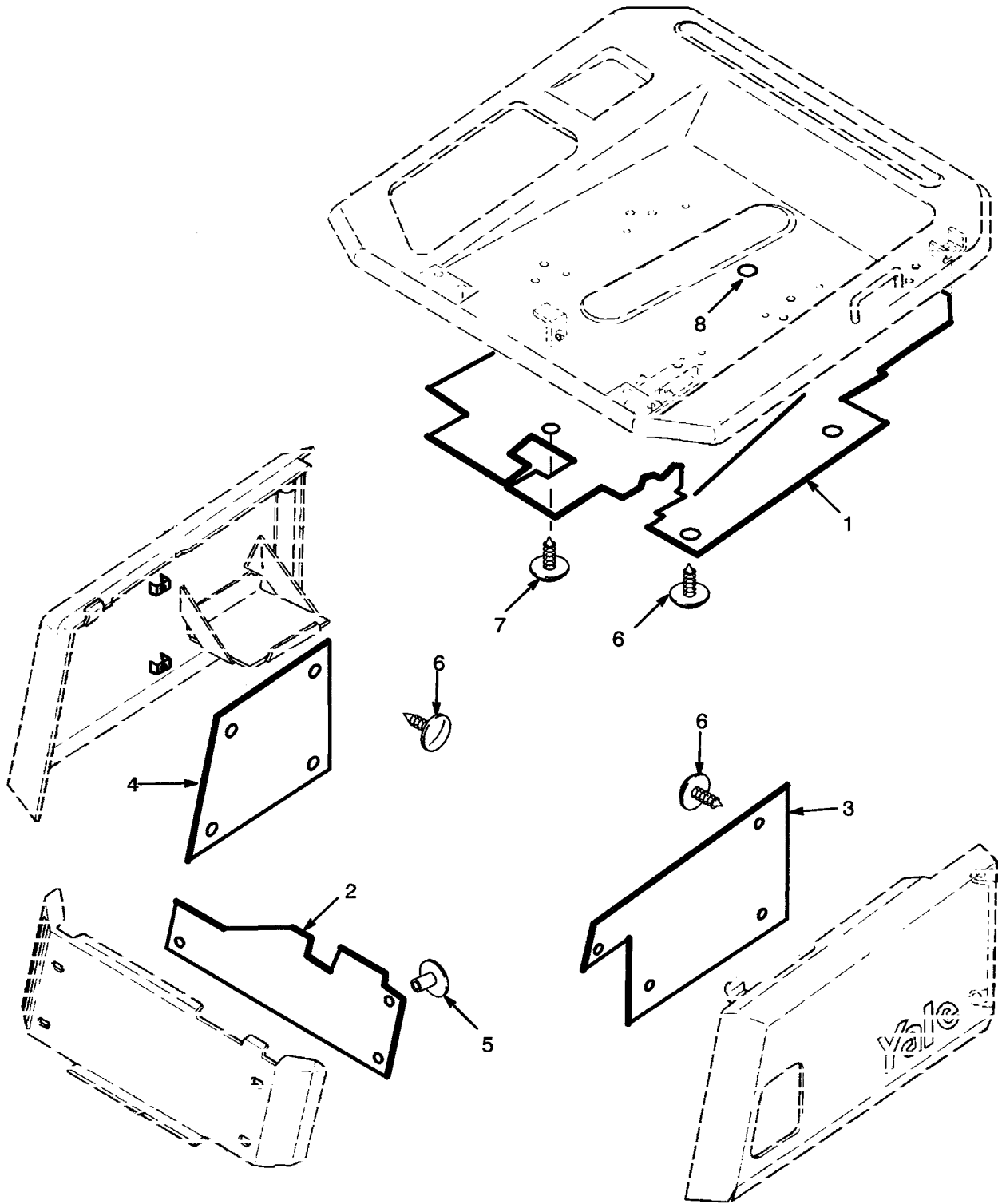

YP260477

ITEM	PART NO.	DESCRIPTION	QTY
1	504241701	Liner (Hood).....	1
2	504246763	Liner (Front Cover)	1
3	504241724	Liner (LH Door).....	1
4	504241725	Liner (RH Door)	1
5	900003273	Button	3
6	518793609	Fastener	14
7	580001090	Fastener	1
8	014195600	Grommet.....	2



Suggest:

For more complete manuals. Please go to the home page.

<https://www.ebooklibonline.com>

If the above button click is invalid. Please download this document first, and then click the above link to download the complete manual.

Thank you so much for reading

COUNTERWEIGHT

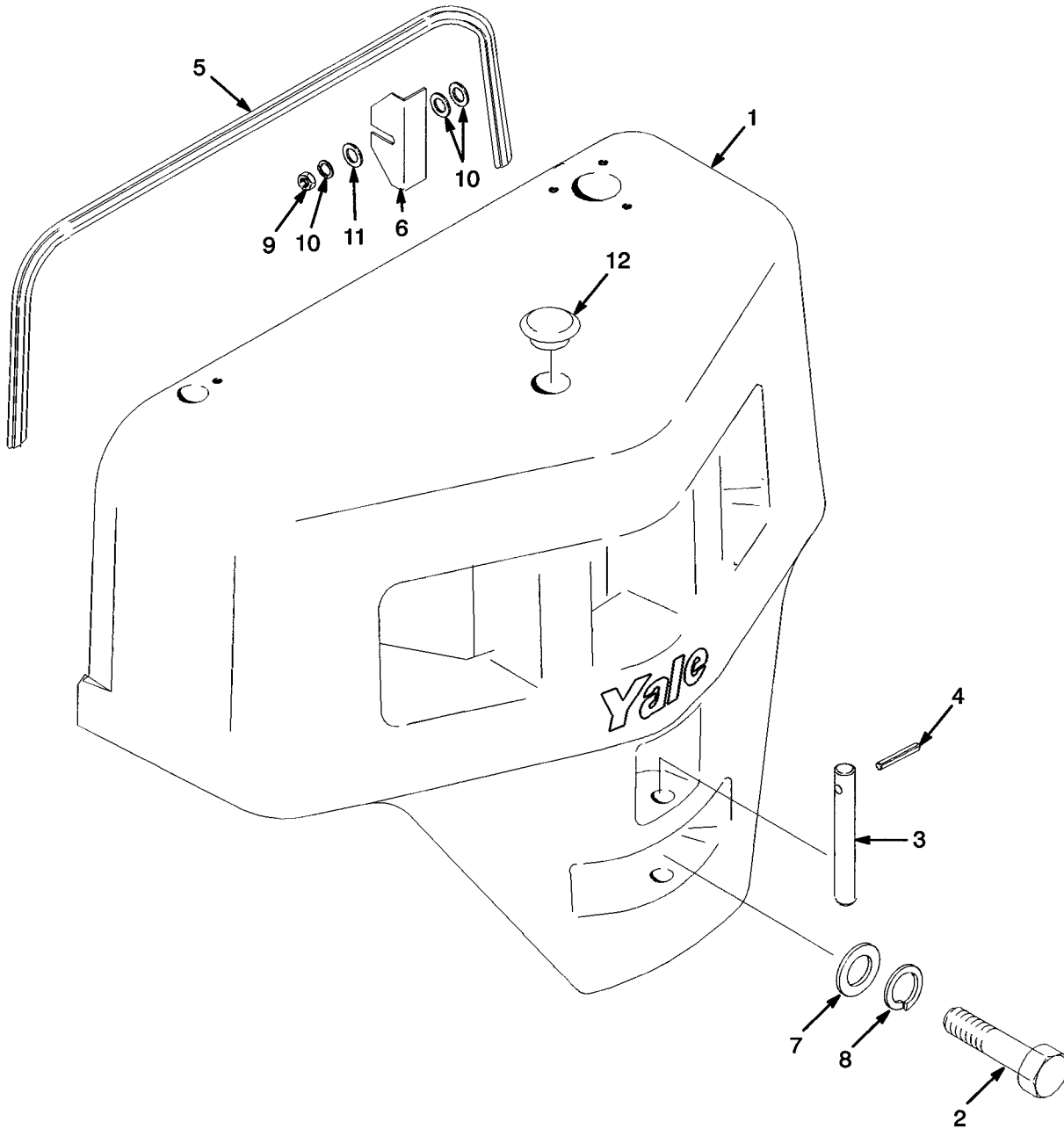

YP260478

COUNTERWEIGHT

ITEM	PART NO.	DESCRIPTION	QTY
1	505975589	Counterweight (GDP 040 RG).....	1
1	505975581	Counterweight (GDP 050 RG).....	1
2	449001398	Capscrew (GDP 040 RG).....	1
2	449001405	Capscrew (GDP 050 RG).....	1
3	505972541	Pin	1
4	449034061	Pin	1
5	504246769	Seal	1
5	916748322	Seal (Rubber) (Optional)	1
6	580000884	Shim (0.059 in.)	AR
6	505970557	Shim (0.109 in.)	AR
7	505970538	Washer	1
8	955400911	Lockwasher	1
9	449015014	Nut	4
10	504226242	Washer	12
11	449022016	Lockwasher	4
12	504241796	Plug	1

<https://www.ebooklibonline.com>

Hello dear friend!

Thank you very much for reading.

Enter the link into your browser.

The full manual is available for immediate download.

<https://www.ebooklibonline.com>