

PARTS MANUAL

**S3.50-5.50XM
(F004)**

CUSTOMER EDITION

HYSTER

SECTIONS

1	FRAME
2	ENGINES
3	FUEL SYSTEM
4	ELECTRICAL SYSTEM
5	TRANSMISSION
6	STEERING SYSTEM
7	BRAKE SYSTEM
8	HYDRAULIC SYSTEM
9	MAST-TWO STAGE LIMITED FREE-LIFT
10	MAST-TWO STAGE FULL FREE-LIFT
11	MAST-THREE STAGE FULL FREE-LIFT
12	OPTIONS
13	NUMERICAL INDEX

TABLE OF CONTENTS

DESCRIPTION	PAGE
A	
ACCELERATOR PEDAL AND BRACKET ASSEMBLY	
FORWARD AND REVERSE LEVER	3-36
MONOTROL	3-38
ACCUMULATOR	12-46
AIR INTAKE AND FILTER SYSTEM.....	3-2
ASSEMBLED ENGINE	
LPG.....	2-2
AUXILIARY TUBE EXTENSION KIT	
TWO STAGE LIMITED FREE-LIFT.....	12-32
B	
BACK-UP ALARM	12-47
BATTERY TRAY LATCH.....	1-10
BRAKE ASSEMBLY	
LONG WHEEL BASE	7-8
SHORT WHEEL BASE	7-6
BRAKE LINES.....	7-10
BRAKE LINKAGE	
DUAL PEDALS	7-4
SINGLE PEDAL	7-2
C	
CAMSHAFT AND OIL PAN	2-14
CARRIAGE	
THREE STAGE FULL FREE-LIFT	11-28
TWO STAGE FULL FREE-LIFT	10-24
TWO STAGE LIMITED FREE-LIFT.....	9-18
CLUTCH PACKS	
⇒S/N F004V02172B	5-10
S/N F004V02173B⇒	5-12
COIL ASSEMBLY	2-4
CONTROL VALVE	
⇒S/N F004V02137B	8-20
CONTROL VALVE AND ATTACHING PARTS	
FIVE FUNCTION	
⇒S/N F004V02137B.....	8-18
S/N F004V02138B⇒.....	8-36
FOUR FUNCTION	
⇒S/N F004V02137B.....	8-16
S/N F004V02138B⇒.....	8-32
THREE FUNCTION	
⇒S/N F004V02137B.....	8-14
S/N F004V02138B⇒.....	8-28
COOLING SYSTEM	2-22
COUNTERWEIGHT	1-12
CYLINDER BLOCK	2-12
CYLINDER HEAD	2-10

<https://www.ebooklibonline.com>

Hello dear friend!

Thank you very much for reading.

Enter the link into your browser.

The full manual is available for immediate download.

<https://www.ebooklibonline.com>

TABLE OF CONTENTS (Continued)

DESCRIPTION	PAGE
D	
DIFFERENTIAL AND HYPOID ASSEMBLY	
⇒S/N T122M01625	5-14
S/N T122M01626⇒	5-16
DISTRIBUTOR	4-40
DRIP SHIELD	2-20
DRIVE AXLE	5-18
DRIVE TIRES AND WHEELS	5-21
E	
ELECTRICAL SYSTEM	
CHASSIS	4-12
DASH PANEL	4-4
EEC	4-14
ENGINE	4-8
ENGINE FUEL SYSTEM	3-6
ENGINE MOUNTS	2-30
EXHAUST SYSTEM	2-28
F	
FAN DRIVE AND ALTERNATOR MOUNTING	2-26
FLOOR PLATES AND COVERS	1-4
FLYWHEEL HOUSING	2-32
FORK	
STANDARD TAPER HOOK TYPE	
3.50XM - 4.00XM	1-38
4.50XM-5.50XM	1-39
FREE-LIFT	
THREE STAGE FULL FREE-LIFT	11-12
FREE-LIFT CYLINDER	
THREE STAGE FULL FREE-LIFT	11-20
TWO STAGE FULL FREE-LIFT	10-16
FRONT HEADLIGHTS	12-38
FUEL FILTERING SYSTEM	3-4
FULL SUSPENSION SEAT	
PENDING PER ECN 74951⇒	1-24
SHEET 1 OF 2	
⇒PENDING PER ECN 74951	1-20
SHEET 2 OF 2	
⇒PENDING PER ECN 74951	1-22
FULL SUSPENSION SWIVEL SEAT	
PENDING PER ECN 74951⇒	1-34
SHEET 1 OF 2	
⇒PENDING PER ECN 74951	1-26
SHEET 2 OF 2	
⇒PENDING PER ECN 74951	1-30
G	
GENERAL TRUCK	1-2

TABLE OF CONTENTS (Continued)

DESCRIPTION	PAGE
H	
HEADER HOSE	
THREE STAGE FULL FREE-LIFT	11-24
TWO STAGE FULL FREE-LIFT	10-20
TWO STAGE LIMITED FREE-LIFT	9-14
HOOD	1-6
HYDRAULIC CONTROL LINES	
⇒S/N F004V02137B	8-6
S/N F004V02138B⇒	8-10
HYDRAULIC CONTROL VALVE	
S/N F004V02138B⇒	8-24
HYDRAULIC FILTER HOUSING	8-42
HYDRAULIC PUMP	8-44
HYDRAULIC SUPPLY AND RETURN	8-2
I	
INNER MAST	
THREE STAGE FULL FREE-LIFT	11-6
TWO STAGE LIMITED FREE-LIFT	9-4
INNER MAST AND FREE-LIFT	
TWO STAGE FULL FREE-LIFT	10-6
INSTRUMENT PANEL	4-2
INTEGRAL SIDE-SHIFT	
THREE STAGE FULL FREE-LIFT	
S3.50XM, S4.00XM, S4.50XM	12-22
S5.50XM, S5.50XMS	12-24
TWO STAGE FULL FREE-LIFT	
S3.50XM, S4.00XM, S4.50XM	12-12
S5.50XM, S5.50XMS	12-14
TWO STAGE LIMITED FREE-LIFT	
S3.50XM, S4.00XM, S4050XM	12-2
S5.50XM, S5.50XMS	12-4
INTEGRAL SIDE-SHIFT CARRIAGE	
1067 MM (42 IN.) CLASS III	
THREE STAGE FULL FREE-LIFT	12-26
TWO STAGE FULL FREE-LIFT	12-16
TWO STAGE LIMITED FREE-LIFT	12-6
1219 MM (48 IN.) CLASS III	
THREE STAGE FULL FREE-LIFT	12-28
TWO STAGE LIMITED FREE-LIFT	12-8
1219 MM (48 IN.) CLASS IV	
THREE STAGE FULL FREE-LIFT	12-30
TWO STAGE FULL FREE-LIFT	12-20
TWO STAGE LIMITED FREE-LIFT	12-10
1219 MM 48 IN. CLASS III	
TWO STAGE FULL FREE-LIFT	12-18
INTERMEDIATE MAST	
THREE STAGE FULL FREE-LIFT	11-4

TABLE OF CONTENTS (Continued)

DESCRIPTION	PAGE
L	
LABELS.....	1-36
LIGHTS BACK-UP AND BRAKE WITHOUT HEAVY DUTY AIR INTAKE OR OVERHEAD EXHAUST	4-46
LIGHTS REAR DRIVE, BACK-UP AND BRAKE WITH HEAVY DUTY AIR INTAKE OR OVERHEAD EXHAUST	4-44
LOAD BACKREST EXTENSION.....	1-40
LPG TANK BRACKET FIXED BOX CAR SPECIAL	3-14
STANDARD	3-12
SWING OUT/DROP DOWN 4.00 BOX CAR SPECIAL	3-24
4.00 BOX CAR SPECIAL WITH METAL STRAP D/B 01/2005⇒	3-30
⇒D/B 01/2005	3-28
STANDARD AND BOX CAR SPECIAL	3-20 3-16
M	
MAIN CYLINDER THREE STAGE FULL FREE-LIFT	11-16
TWO STAGE FULL FREE-LIFT S3.50XM, S4.00XM, S4.50XM	10-10
S5.50XM, S5.50XMS	10-14
TWO STAGE LIMITED FREE-LIFT S3.50XM, S4.00XM, S4.50XM	9-10
S5.50XM, S5.50XMS	9-12
MAIN LIFT THREE STAGE FULL FREE-LIFT	11-8
TWO STAGE LIMITED FREE-LIFT.....	9-6
MAST INSTALLATION.....	8-48
MASTER CYLINDER AND BRAKE BOOSTER.....	7-12
MONOTROL PEDAL	3-40
N	
NON-SUSPENSION SEAT PENDING PER ECN 74951⇒	1-18
⇒PENDING PER ECN 74951	1-16
O	
OIL PUMP	2-18
OUTER MAST THREE STAGE FULL FREE-LIFT	11-2
TWO STAGE LIMITED FREE-LIFT.....	9-2
OUTER MAST AND MAIN LIFT TWO STAGE FULL FREE-LIFT	10-2
OVERHEAD GUARD.....	1-14

TABLE OF CONTENTS (Continued)

DESCRIPTION	PAGE
P	
PARK BRAKE LEVER	7-14
PRESSURE REGULATOR USED WITH PAPER ROLL	8-50
Q	
QUICK DISCONNECT	12-36
R	
REAR DRIVE LIGHT SINGLE	12-40
REGULATING SYSTEM	3-10
S	
SHIFT LEVERS	6-4
STARTER	4-42
STEER AXLE	6-6
STEER CYLINDER	6-10
STEER TIRES AND WHEELS	6-12
STEERING COLUMN	6-2
STROBE LIGHT HIGH MOUNT	12-42
LOW MOUNT	12-44
T	
THROTTLE BODY AND LPG MIXER	3-8
THROTTLE LINKAGE	3-34
TILT CYLINDER	8-45
TORQUE CONVERTER	5-2
TRANSMISSION	5-4
TRANSMISSION CONTROL VALVE SHEET 1 OF 2	5-6
SHEET 2 OF 2	5-8
TRANSMISSION COOLING AND STEERING LINES	8-40
TUBE EXTENSION KITS TWO AND THREE STAGE FULL FREE-LIFT	12-34
V	
VALVE COVER AND INLET MANIFOLD	2-6
W	
WIRE HARNESS CHASSIS PENDING PER ECN 74951⇒	4-32
⇒PENDING PER ECN 74951	4-30
DASH ⇒S/N F004V01696B	4-16
S/N F004V01697B⇔S/N F004V03148C	4-18
S/N F004V03149C⇒	4-20
ENGINE SHEET 1 OF 2	4-23

TABLE OF CONTENTS (Continued)

DESCRIPTION	PAGE
W (continued)	
SHEET 2 OF 2	4-26
INTERFACE	4-36
LPG REGULATER	4-28
POWER DISTRIBUTION GROUP	4-38

SECTION 1
FRAME

DESCRIPTION	PAGE
BATTERY TRAY LATCH.....	1-10
COUNTERWEIGHT	1-12
FLOOR PLATES AND COVERS	1-4
FORK	
STANDARD TAPER HOOK TYPE	
3.50XM - 4.00XM	1-38
4.50XM-5.50XM	1-39
FULL SUSPENSION SEAT	
PENDING PER ECN 74951⇒	1-24
SHEET 1 OF 2	
⇒PENDING PER ECN 74951	1-20
SHEET 2 OF 2	
⇒PENDING PER ECN 74951	1-22
FULL SUSPENSION SWIVEL SEAT	
PENDING PER ECN 74951⇒	1-34
SHEET 1 OF 2	
⇒PENDING PER ECN 74951	1-26
SHEET 2 OF 2	
⇒PENDING PER ECN 74951	1-30
GENERAL TRUCK	1-2
HOOD.....	1-6
LABELS.....	1-36
LOAD BACKREST EXTENSION.....	1-40
NON-SUSPENSION SEAT	
PENDING PER ECN 74951⇒	1-18
⇒PENDING PER ECN 74951	1-16
OVERHEAD GUARD.....	1-14

GENERAL TRUCK (Figure 1-1)

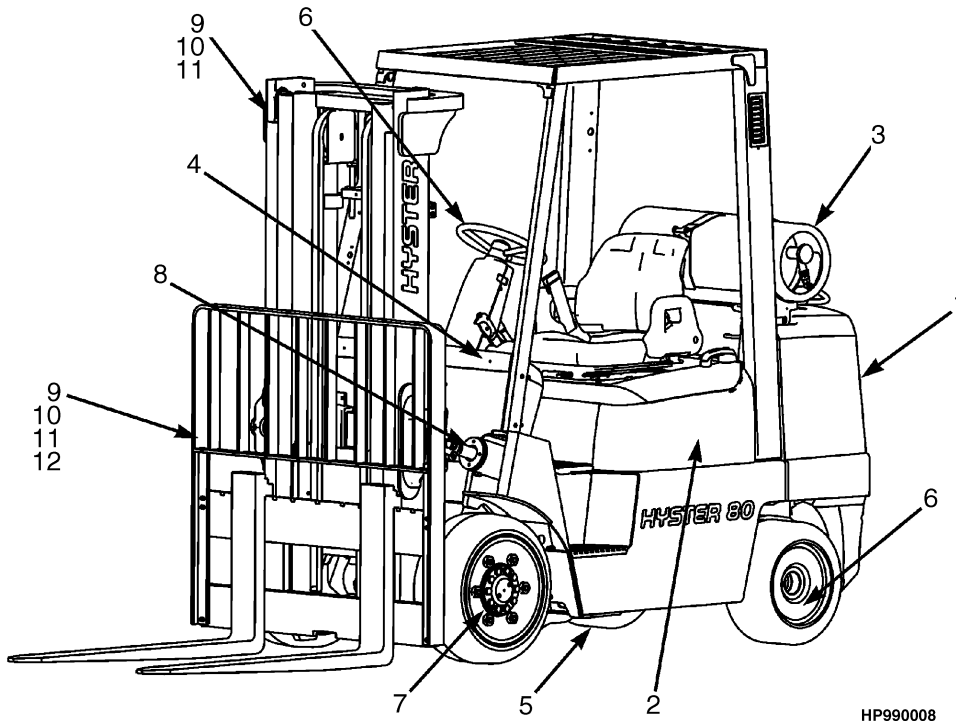

HP990008

ITEM	PART NO.	DESCRIPTION	QTY
1	Frame (☞ Figure 1-2, ☞ Figure 1-3, ☞ Figure 1-5)
2	Engine (☞ Figure 2-1)
3	Fuel System (☞ Figure 3-2, ☞ Figure 3-3)
4	Electrical System (☞ Figure 4-2, ☞ Figure 4-1, ☞ Figure 4-12, ☞ Figure 4-3, ☞ Figure 4-9)
5	Transmission (☞ Figure 5-2)
6	Steering System (☞ Figure 6-1)
7	Brake System (☞ Figure 7-1, ☞ Figure 7-2)
8	Hydraulic System (☞ Figure 8-1)
9	Mast-Two Stage Limited Free-Lift (☞ Figure 9-1)
10	Mast-Two Stage Full Free-Lift (☞ Figure 10-1)
11	Mast-Three Stage Full Free-Lift (☞ Figure 11-1)
12	Optional Equipment (☞ Figure 12-19, ☞ Figure 12-20, ☞ Figure 12-21, ☞ Figure 12-22, ☞ Figure 12-24)

FLOOR PLATES AND COVERS (Figure 1-2)

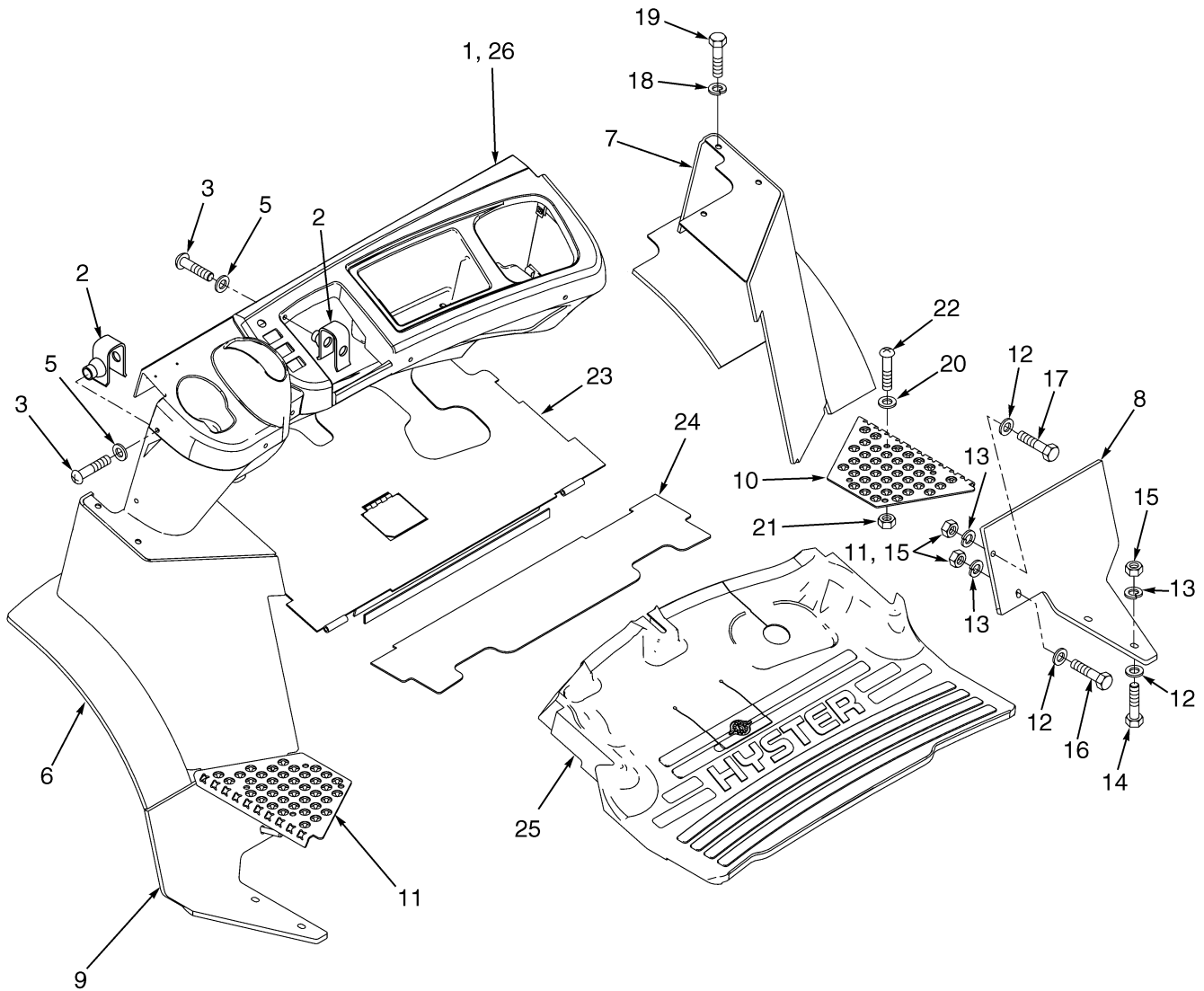

HP120695

FLOOR PLATES AND COVERS**KEY:****A: Short Wheel Base****B: Long Wheel Base**

ITEM	PART NO.	DESCRIPTION	QTY	
			A	B
1	2043883	Panel (Cowl) (Single Brake Pedal).....	1	1
1	2043882	Panel (Cowl) (Dual Brake Pedal)	1	1
2	1350215	Nut (Foldover).....	6	6
3	1525248	Screw.....	10	10
4	c 1402100	Spacer (Lower Fender) (Not Illustrated)	4	4
5	1399399	Washer	10	10
6	b 1402053	Fender (LH)	1	..
6	c 1402052	Fender (LH)	1	1
6	a 1402051	Fender (LH)	1
7	b 1402083	Fender (RH).....	1	..
7	c 1402082	Fender (RH).....	1	1
7	a 1402081	Fender (RH).....	..	1
8	b 1402113	Fender (Lower LH).....	1	..
8	c 1402112	Fender (Lower LH).....	1	1
8	a 1402111	Fender (Lower LH).....	..	1
9	b 1402117	Fender (Lower RH)	1	..
9	c 1402116	Fender (Lower RH)	1	1
9	a 1402115	Fender (Lower RH)	1
10	1402078	Step Plate (LH)	1	1
11	1402079	Step Plate (RH)	1	1
12	296421	Washer	16	16
13	292682	Lockwasher.....	10	10
14	293631	Capscrew.....	4	4
15	302401	Locknut	10	10
16	293636	Capscrew.....	4	4
17	293629	Capscrew.....	2	2
18	292681	Lockwasher.....	4	4
19	293615	Capscrew.....	4	4
20	296418	Washer	8	8
21	302400	Locknut	8	8
22	296167	Capscrew.....	8	8
23	1510686	Floorplate (Front).....	1	1
24	1510688	Floorplate (Rear)	1	1
25	1402347	Floormat	1	1
26	2043862	Dash Panel	1	1
26	2043882	Panel (Cowl) (Dual Brake Pedal)	1	1
26	2043883	Panel (Cowl) (Single Brake Pedal).....	1	1
27	1151313	Cap (Not Illustrated).....	2	2

FOOTNOTES:

- a** Long Wheel Base and S100XM-Box Car Special Wide Tread
- b** Short Wheel Base-Standard Tread
- c** Short Wheel Base-Wide/Long Wheel Base and S100XM-Box Car Special Standard

HOOD (Figure 1-3)

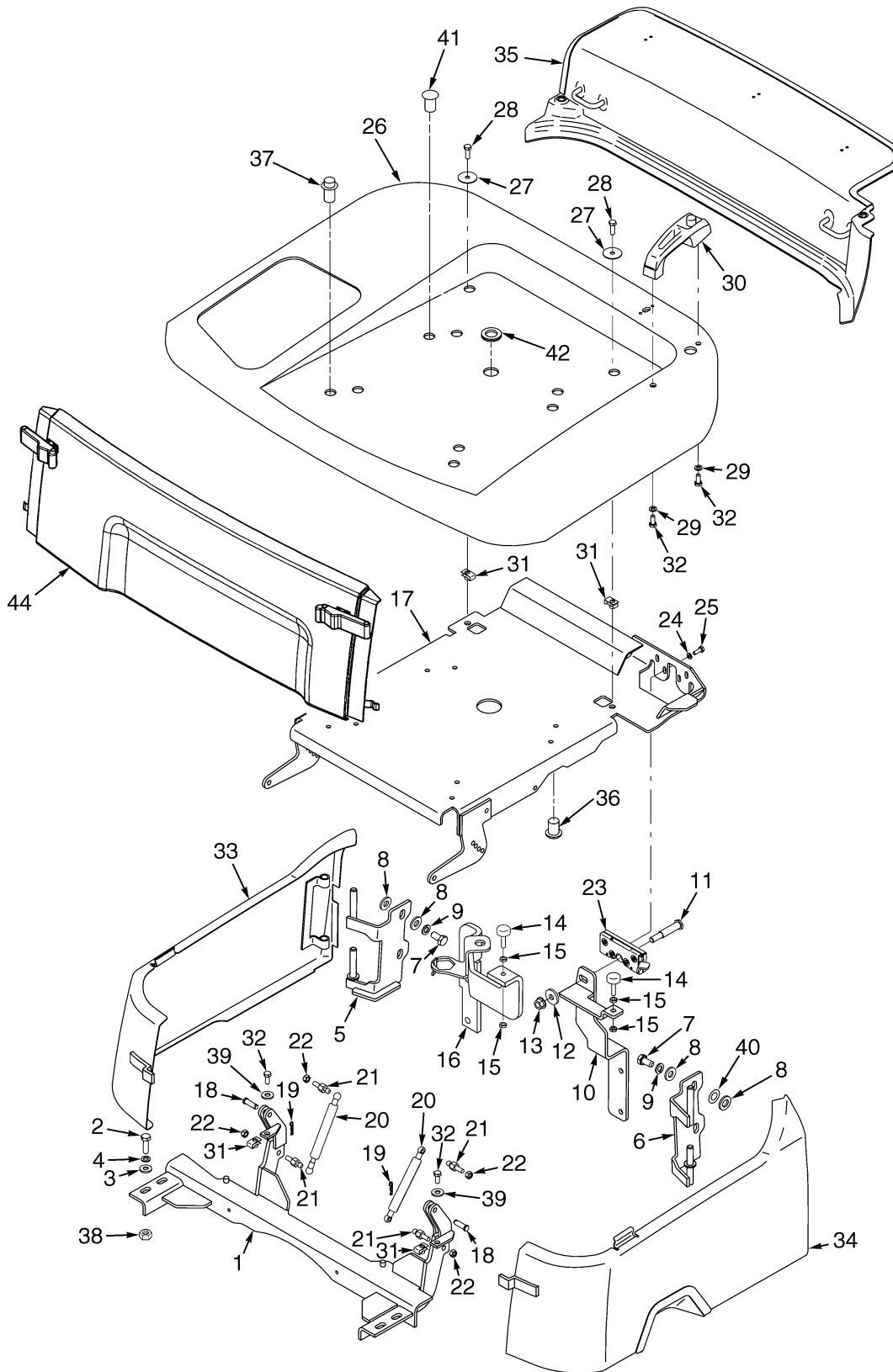

HP120720

HOOD

ITEM	PART NO.	DESCRIPTION	QTY
1	1402457	Crossmember	1
2	287860	Capscrew	4
3	320160	Washer	8
4	292682	Lockwasher	8
5	1402458	Bracket (Hinge Pin RH)	1
6	1402459	Bracket (Hinge Pin LH)	1
7	132860	Capscrew	4
8	320162	Washer	4
9	292683	Lockwasher	4
10	1521435	Bracket (Striker)	1
11	1401006	Striker Bolt	1
12	1371414	Washer	1
13	300937	Locknut	1
14	1347088	Stop Screw	1
15	15001	Nut	4
16	1510393	Bracket	1
17	1402456	Seat Pan	1
18	237947	Pin	2
19	1362714	Cotter Pin	2
20	1377992	Gas Spring	2
21	1518872	Ball Stud	3
22	302400	Locknut	4
23	1401003	Hood Latch	1
24	320156	Washer	4
25	199563	Capscrew	4
26	c 1401061	Hood	1
26	1511828	Liner	1
26	d 1606401	Hood	1
27	1402455	Washer	2
28	1354380	Capscrew	2
29	292681	Lockwasher	2
30	1513862	Handle	1
31	1398062	Nut	4
32	136681	Capscrew	4
33	a 1528637	Panel (RH)	1
34	a 1528638	Panel (LH)	1
34	b 1541147	Panel (LH)	1
34	b 1541151	Panel (RH)	1
35	1401063	Radiator Cover Assembly (Counterweight Exhaust)	1
35	1401064	Radiator Cover Assembly (Overhead Exhaust)	1
35	1401093	Radiator Cover Assembly (Box Car Special)	1
36	1361087	Button	6
37	280644	Button	4
38	136692	Nut	4
39	320158	Washer	4
40	1392740	Shim (0,991 mm)	AR
41	1347045	Fastener	4
42	c 1359587	Grommet	1
42	d 1561015	Grommet	1

HOOD

ITEM	PART NO.	DESCRIPTION	QTY
43	1518872	Ball Stud	1
44	ab 1528636	Panel (Center Front)	1

FOOTNOTES:

- a** Standard
- b** Vented
- c** ⇒ PENDING PER ECN 74951
- d** PENDING PER ECN 74951 ⇒

BATTERY TRAY LATCH (Figure 1-4)

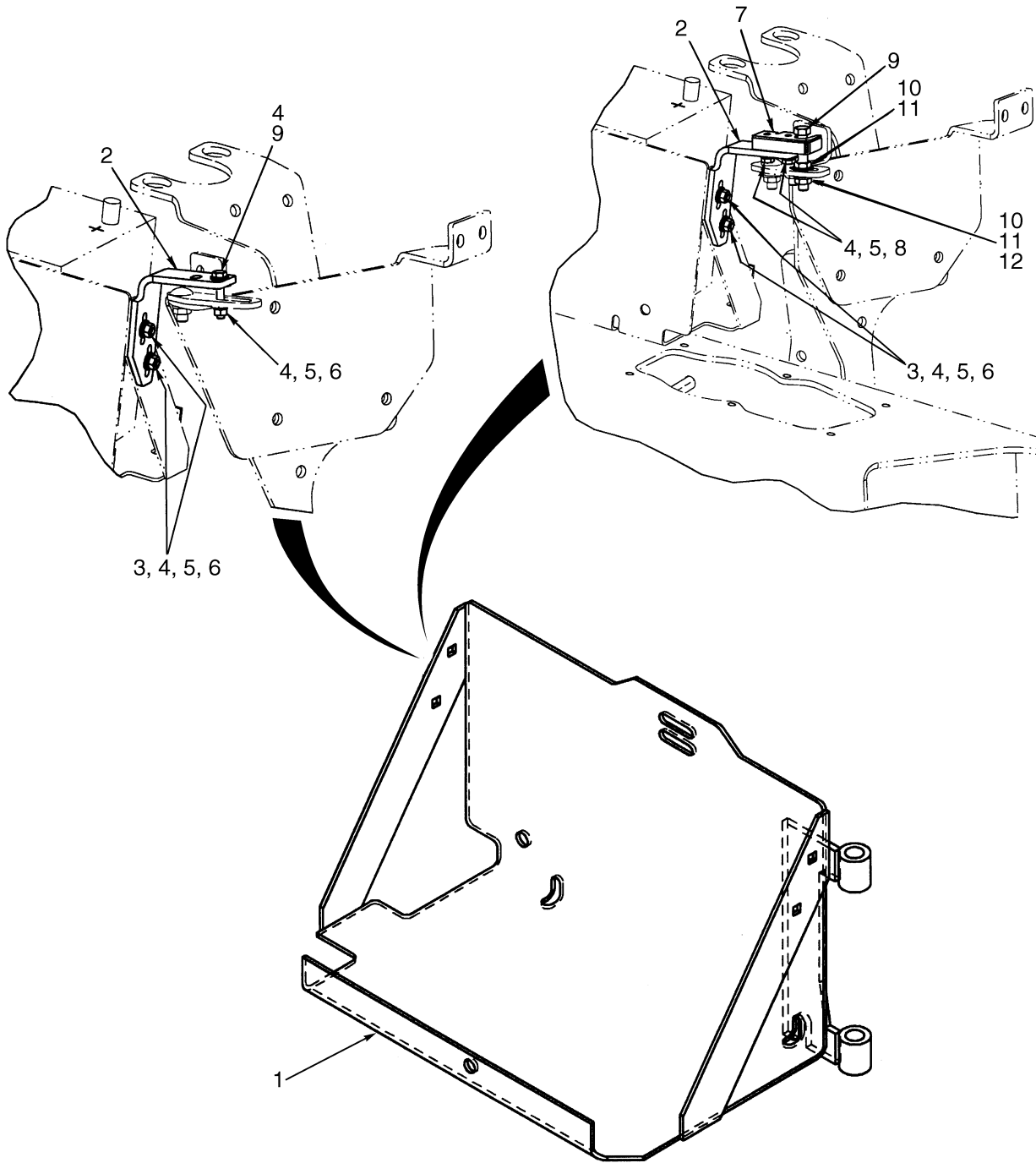

BP080198

BATTERY TRAY LATCH

ITEM	PART NO.	DESCRIPTION	QTY
1	1521295	Tray	1
2	1520689	Latch Bracket.....	1
3	15937	Bolt	2
4	15127	Washer	4
5	15154	Lockwasher.....	4
6	15054	Nut	2
7	1476422	Latch (Rotary).....	1
8	18462	Capscrew.....	2
9	16379	Capscrew.....	1
10	15134	Washer	2
11	15086	Nut	2
12	15156	Lockwasher.....	1

COUNTERWEIGHT (Figure 1-5)

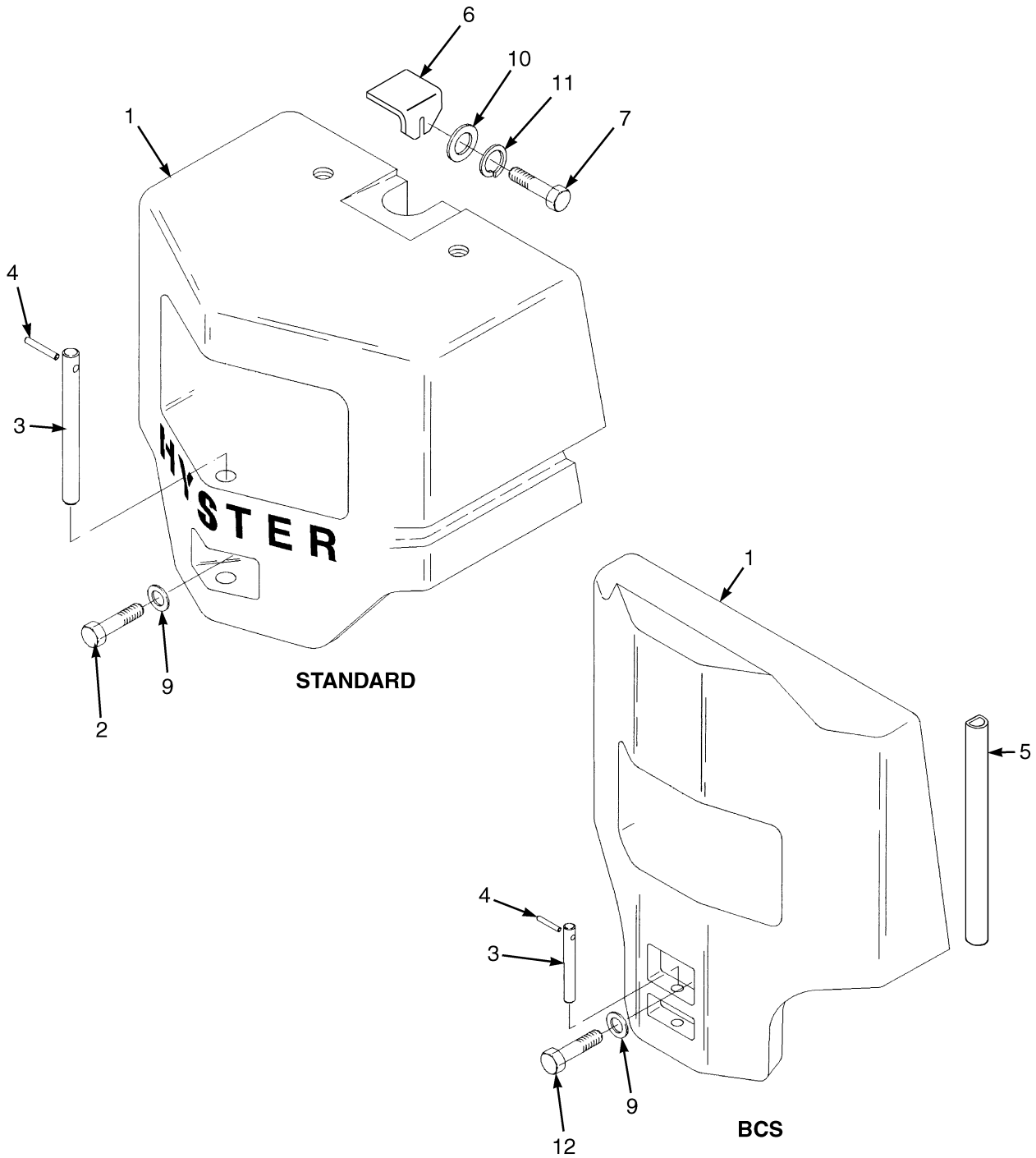

HP120721

COUNTERWEIGHT

ITEM	PART NO.	DESCRIPTION	QTY
1	1401505	Counterweight	1
1	1401506	Counterweight (4.00XM).....	1
1	1532309	Counterweight (S4.00XM-Box Car Special)	1
1	1401507	Counterweight (4.50XM).....	1
1	1532310	Counterweight (S4.50XM-Box Car Special)	1
1	1401508	Counterweight (5.50XM).....	1
1	1532311	Counterweight (S5.50XMS).....	1
1	1536650	Counterweight (S5.50XMS-Paper Roll Special)	1
2	17393	Capscrew (Standard).....	1
3	1300121	Tow Pin (Box Car Special)	1
3	1401579	Tow Pin (Standard)	1
4	302492	Pin	1
5	1401583	Seal (4.50XM-5.50XM)	2
5	1401586	Seal (3.50XM-4.00XM, S4.00XM-Box Car Special-S4.50XM-Box Car Special).....	2
5	1401585	Seal (S5.50XM-Box Car Special/S5.50XM-Paper Roll Special)	2
6	1335763	Shim (2,769 mm)	4
7	132861	Capscrew.....	4
8	15168	Lockwasher.....	1
9	149531	Washer	10
10	320158	Washer	2
11	292681	Lockwasher.....	2
12	17384	Capscrew (Box Car Special).....	1

OVERHEAD GUARD (Figure 1-6)

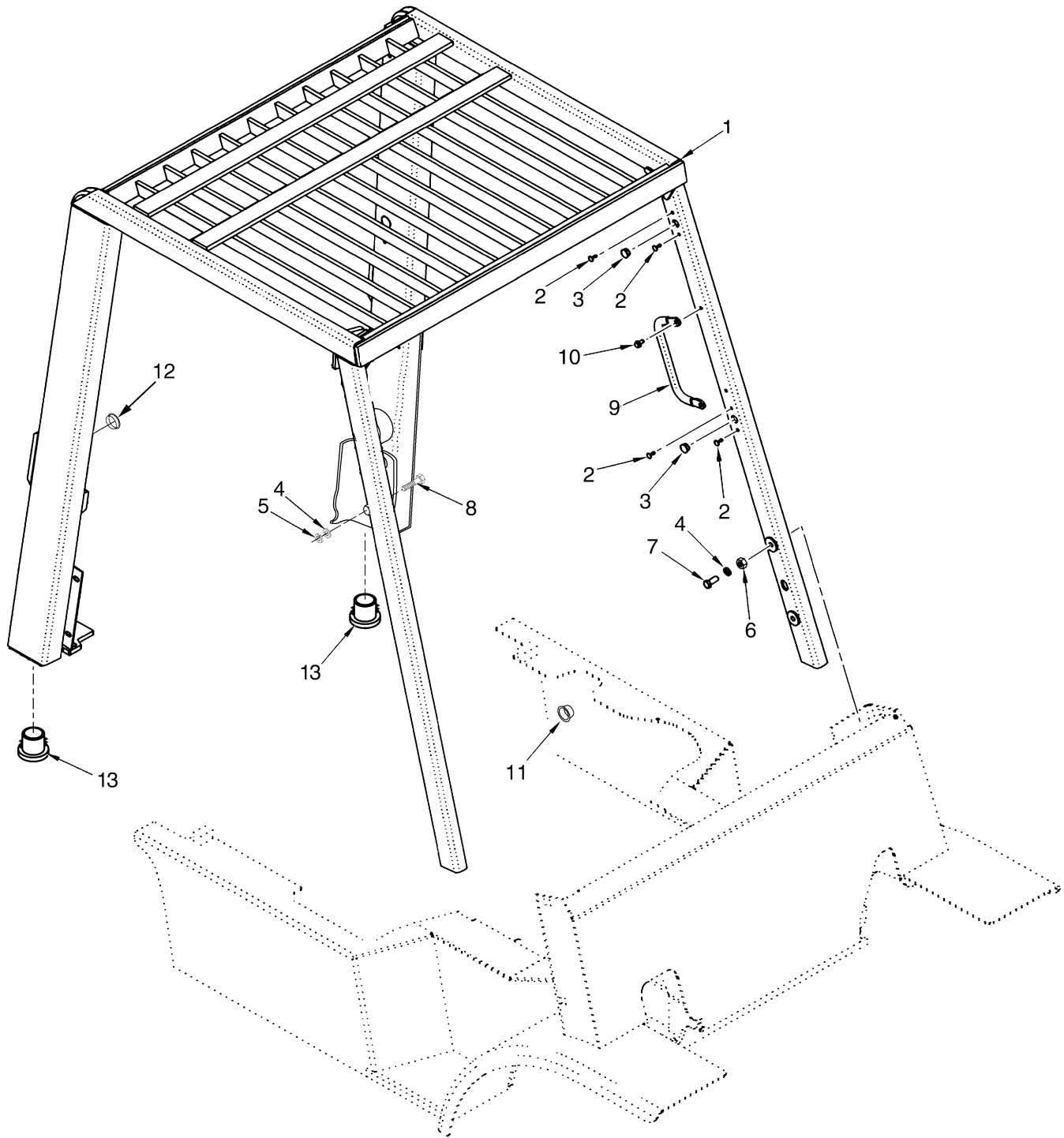

BP120026

OVERHEAD GUARD

ITEM	PART NO.	DESCRIPTION	QTY
1	1466772	Overhead Guard (Standard)	1
1	1466773	Overhead Guard (Reduced Height)	1
2	1363916	Plug	12
2	1363916	Plug (Type EEC)	16
3	1363917	Plug	5
4	320161	Washer	12
5	292683	Lockwasher	4
6	300937	Locknut	4
7	1343990	Capscrew	4
8	293644	Capscrew	4
9	2035800	Handle	1
10	316678	Screw	2
11	1151313	Cap	2
12	1538159	Plug (Type EEC)	2
13	1356377	Plug	2
14	1301286	Mirror	1
15	1581281	Mirror Bracket	1
16	316678	Screw	2
	1580788	Mirror Plate	1

NON-SUSPENSION SEAT (Figure 1-7) (⇒PENDING PER ECN 74951)

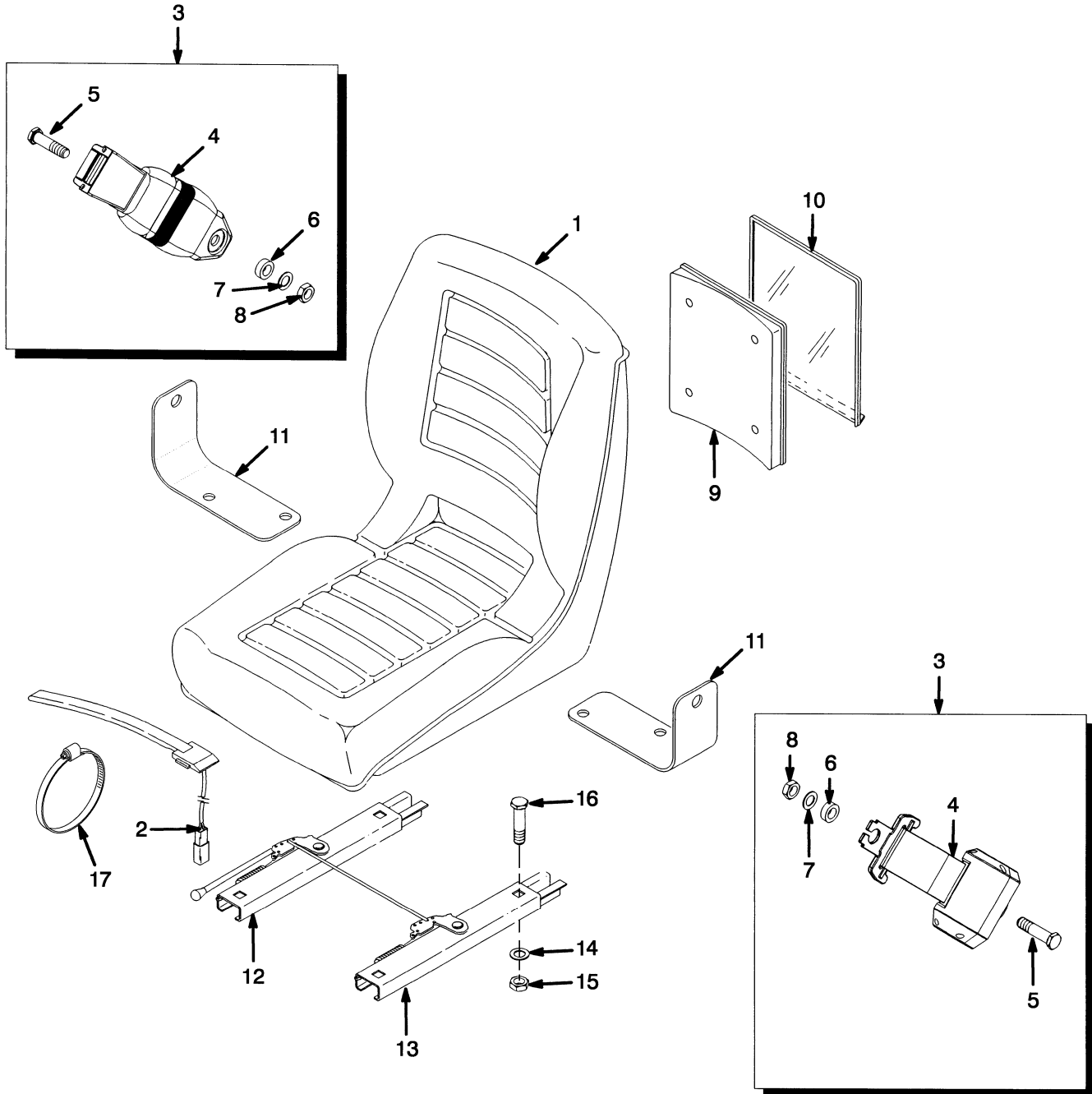

HP120722

NON-SUSPENSION SEAT
(⇒PENDING PER ECN 74951)

ITEM	PART NO.	DESCRIPTION	QTY
	1460231	Non-Suspension Seat.....	1
1	364911	Seat.....	1
2	2037311	Switch Assembly	1
3	1461081	Seat Belt Kit.....	1
4	Seat Belt	1
5	Screw	2
6	Washer.....	2
7	Washer.....	2
8	Nut	2
9	335988	Base	1
10	335991	Cover	1
11	1470175	Bracket	1
12	1470176	Seat Rail.....	1
13	1470177	Seat Rail.....	1
14	15175	Washer	4
15	145639	Nut	4
16	18498	Capscrew.....	4
17	137852	Strap Clamp.....	AR

NON-SUSPENSION SEAT (Figure 1-8) (PENDING PER ECN 74951⇒)

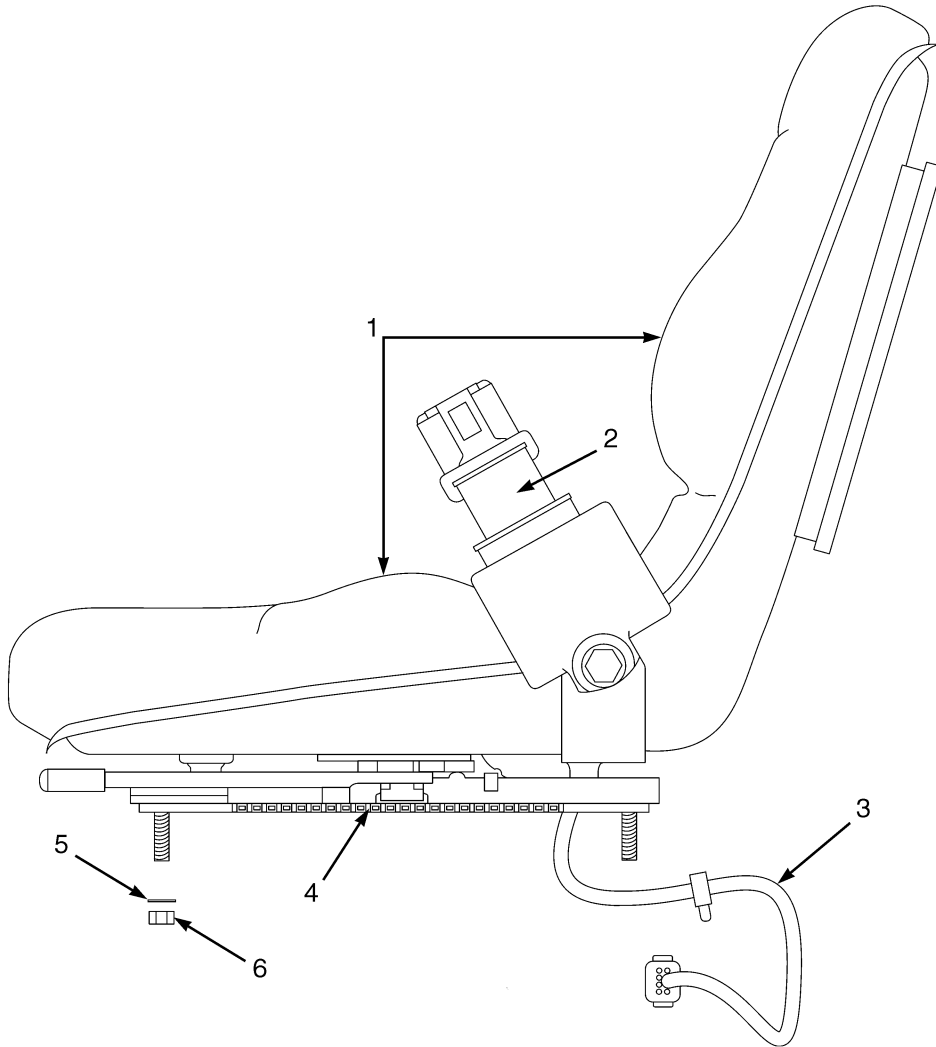

BP120138

**NON-SUSPENSION SEAT
(PENDING PER ECN 74951⇒)**

ITEM	PART NO.	DESCRIPTION	QTY
	1593409	Non-Suspension Seat (Vinyl).....	1
1	1563351	Cushions (Vinyl)	1
1	a 1563215	Sensor (Operator Presence)	1
2	1598504	Seat Belt Kit.....	1
3	2075429	Wire Harness	1
4	1459173	Slide Kit	1
5	15175	Washer	4
6	145639	Nut.....	4

FOOTNOTES:

a Not Illustrated

FULL SUSPENSION SEAT (Figure 1-9) SHEET 1 OF 2 (⇒PENDING PER ECN 74951)

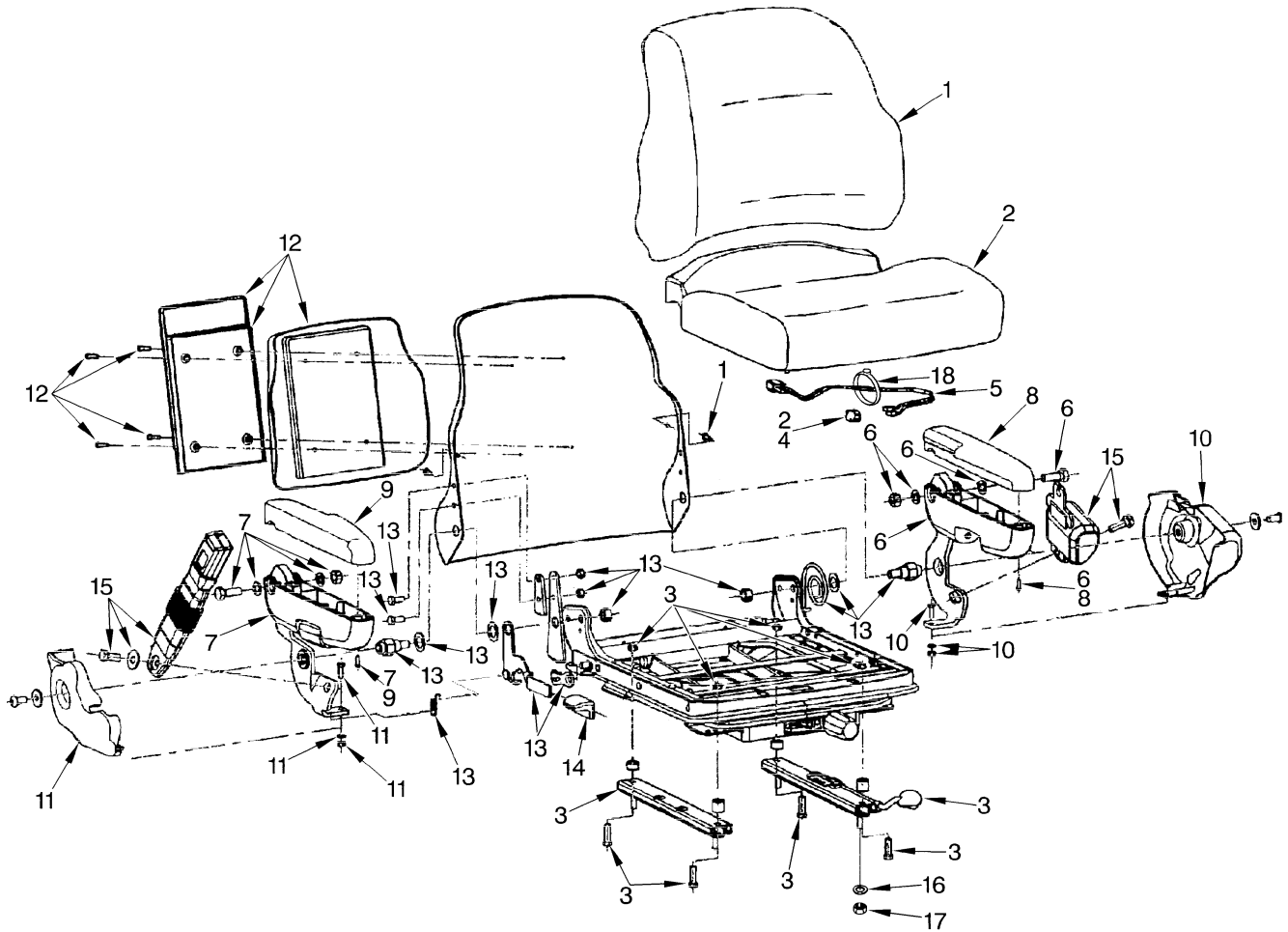

HP120658

**FULL SUSPENSION SEAT
SHEET 1 OF 2
(⇒PENDING PER ECN 74951)**

ITEM	PART NO.	DESCRIPTION	QTY
	1466006	Full Suspension Seat (Vinyl).....	1
	1466007	Full Suspension Seat (Fabric)	1
1	1467533	Back Cushion (Vinyl)	1
1	1467535	Back Cushion (Fabric)	1
2	1467534	Seat Cushion (Vinyl).....	1
2	1467536	Seat Cushion (Fabric)	1
3	1467513	Slider Kit	1
4	1467514	Switch (Seat)	1
5	1467515	Wire Harness	1
6	1467516	Armrest (LH) (LH).....	1
7	1467517	Armrest (RH) (RH)	1
8	1467518	Cap (LH).....	1
9	1467519	Cap (RH)	1
10	1467520	Cover (LH)	1
11	1467521	Cover (RH)	1
12	1467522	Holder Kit.....	1
13	1467530	Recliner Kit.....	1
14	1467531	Recliner Knob.....	1
15	1467532	Seat Belt Kit.....	1
16	15175	Washer	4
17	145639	Nut	4
18	137852	Strap Clamp.....	1



Suggest:

For more complete manuals. Please go to the home page.

<https://www.ebooklibonline.com>

If the above button click is invalid. Please download this document first, and then click the above link to download the complete manual.

Thank you so much for reading

FULL SUSPENSION SEAT (Figure 1-10) SHEET 2 OF 2 (⇒PENDING PER ECN 74951)

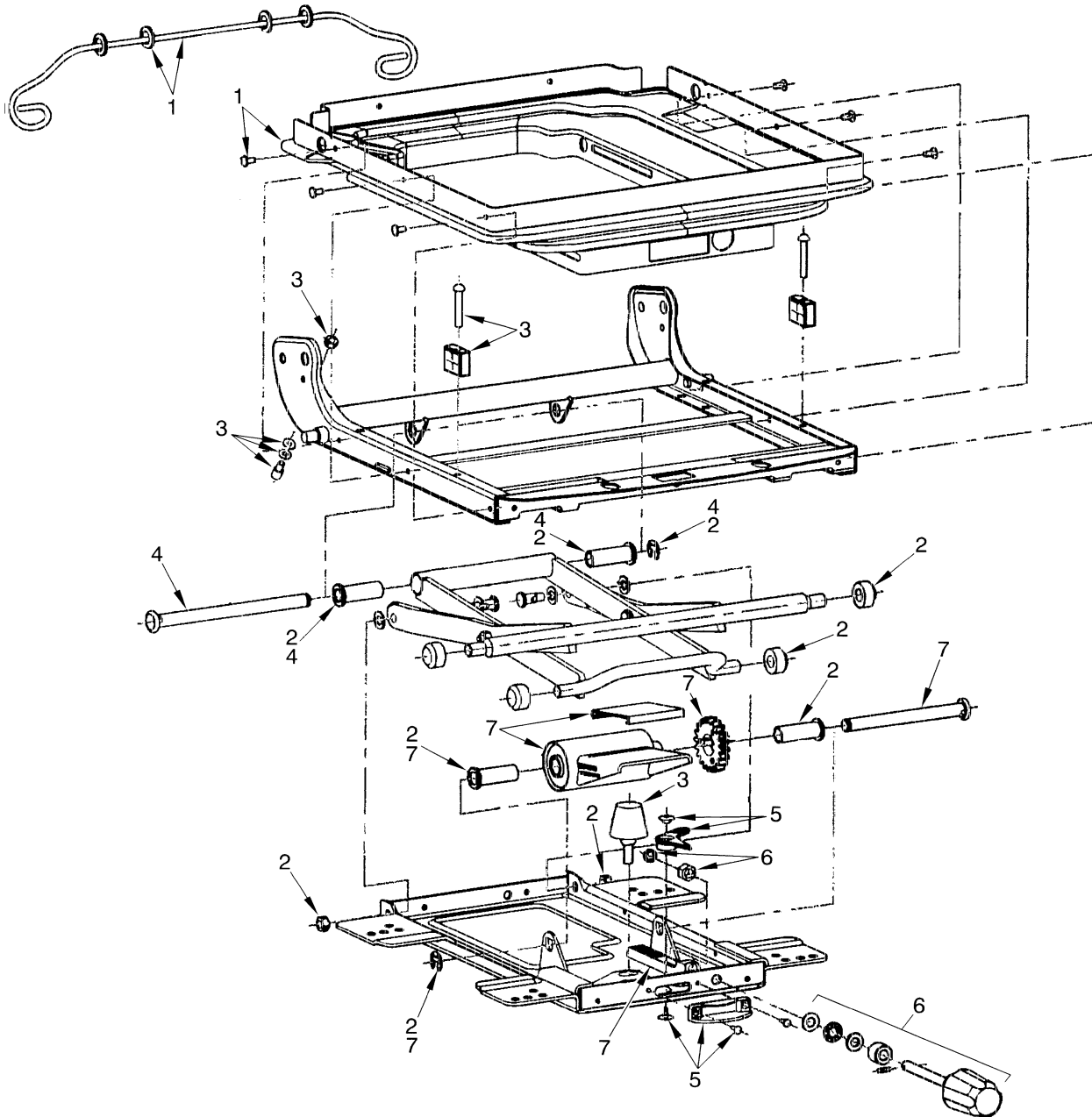

HP120213

**FULL SUSPENSION SEAT
SHEET 2 OF 2
(⇒PENDING PER ECN 74951)**

ITEM	PART NO.	DESCRIPTION	QTY
	1466006	Full Suspension Seat (Vinyl).....	1
	1466007	Full Suspension Seat (Fabric)	1
1	1467523	Boot Kit.....	1
2	1467524	Roller and Bearing Kit	1
3	1467525	Bumper and Stop Kit	1
4	1467526	Bearing Shaft Kit	1
5	1467527	Weight Adjuster Indicator Kit	1
6	1467528	Knob Kit.....	1
7	1467529	Suspension Spring Kit.....	1

<https://www.ebooklibonline.com>

Hello dear friend!

Thank you very much for reading.

Enter the link into your browser.

The full manual is available for immediate download.

<https://www.ebooklibonline.com>