

PARTS MANUAL

ELECTRIC

**A1.00-1.50XL
(C203)**

CUSTOMER EDITION

HYSTER

SECTIONS

1	FRAME
2	ELECTRICAL SYSTEM
3	DRIVE UNIT
4	STEERING SYSTEM
5	BRAKE/ACCELERATOR SYSTEM
6	HYDRAULIC SYSTEM
7	MAST-TWO STAGE LIMITED FREE-LIFT
8	MAST-THREE STAGE FULL FREE-LIFT
9	MAST-TWO STAGE FULL FREE-LIFT
10	OPTIONS
11	NUMERICAL INDEX

TABLE OF CONTENTS

DESCRIPTION	PAGE
A	
ACCELERATOR	5-12
ACCELERATOR PEDAL.....	5-14
B	
BRAKE	
⇒S/N C203A03249A	5-2
S/N C203A03250A⇒	5-4
BRAKE DRUM.....	5-6
BRAKE LINES	5-8
C	
CARRIAGE	
FOUR ROLLER	
TWO STAGE LIMITED FREE-LIFT	7-10
THREE STAGE FULL FREE-LIFT	8-18
TWO STAGE FULL FREE-LIFT	9-14
CONTACTOR	
BY-PASS	
⇒S/N C203A-2437Y	2-13
FORWARD/REVERSE	
⇒S/N C203A-2436Y	2-10
REGENERATIVE BRAKING	
⇒S/N C203A-2436Y	2-14
CONTACTOR PANEL	
⇒S/N C203A-2436Y	2-8
CONTROL VALVE	6-10
CONTROL VALVE LEVER AND ATTACHING PARTS	6-6
E	
ELECTRICAL SYSTEM	
⇒S/N C203A-2436Y	2-2
S/N C203A-2437Y⇒	2-4
F	
FORK	
80 MM X 40 MM	
STANDARD TAPER.....	10-2
FRAME	1-2
FREE-LIFT	
THREE STAGE FULL FREE-LIFT	8-10
TWO STAGE FULL FREE-LIFT	9-8
FREE-LIFT CYLINDER	
THREE STAGE FULL FREE-LIFT	8-16
TWO STAGE FULL FREE-LIFT	9-12
H	
HAND PUMP	4-8
HEADER HOSE	
THREE STAGE FULL FREE-LIFT	8-22
TWO STAGE FULL FREE-LIFT	9-18

<https://www.ebooklibonline.com>

Hello dear friend!

Thank you very much for reading.

Enter the link into your browser.

The full manual is available for immediate download.

<https://www.ebooklibonline.com>

TABLE OF CONTENTS (Continued)

DESCRIPTION	PAGE
H (continued)	
TWO STAGE LIMITED FREE-LIFT	7-14
HYDRAULIC MOTOR	
⇒S/N C203A-02436Y	6-14
S/N C203A-02437Y⇒	6-16
HYDRAULIC PUMP	6-12
HYDRAULIC SYSTEM	6-2
I	
INNER MAST	
THREE STAGE FULL FREE-LIFT	8-6
TWO STAGE FULL FREE-LIFT	9-4
TWO STAGE LIMITED FREE-LIFT	7-4
INTEGRAL SIDE-SHIFT ASSEMBLY	
THREE STAGE FULL FREE-LIFT	8-20
INTEGRAL SIDE-SHIFT CARRIAGE	
TWO STAGE FULL FREE-LIFT	9-16
TWO STAGE LIMITED FREE-LIFT	7-12
INTERMEDIATE MAST	
THREE STAGE FULL FREE-LIFT	8-4
L	
LABELS	1-7
LIFT	
TWO STAGE LIMITED FREE-LIFT	7-6
LIFT CYLINDER	
TWO STAGE LIMITED FREE-LIFT	7-8
LINE CONTACTOR	
⇒S/N C203A-2436Y	2-12
LOAD BACKREST	
SIDE-SHIFT	10-8
LOAD BACKREST EXTENSION	1-16
M	
MAIN CYLINDER	
LEFT HAND	
TWO STAGE FULL FREE-LIFT	9-10
RIGHT HAND	
TWO STAGE FULL FREE-LIFT	9-11
THREE STAGE FULL FREE-LIFT	8-14
MAIN LIFT	
THREE STAGE FULL FREE-LIFT	8-8
TWO STAGE FULL FREE-LIFT	9-6
MASTER CYLINDER	5-10
MASTER DRIVE UNIT	
D/B 11/2001⇒	3-8
⇒D/B 11/2001	3-4
MASTER DRIVE UNIT ASSEMBLY	3-2

TABLE OF CONTENTS (Continued)

DESCRIPTION	PAGE
N	
NON-SUSPENSION SEAT	1-8
O	
OUTER MAST	
THREE STAGE FULL FREE-LIFT	8-2
TWO STAGE FULL FREE-LIFT	9-2
TWO STAGE LIMITED FREE-LIFT	7-2
OVERHEAD GUARD	1-14
P	
PARK BRAKE	5-7
PUMP	
FLOW REGULATOR	
SHEET 1 OF 2	6-18
SHEET 2 OF 2	6-20
S	
SEMI-SUSPENSION SEAT	1-10
WITH ARM REST	1-12
SHIFT LEVER	4-4
SIDE-SHIFT CARRIAGE	10-4
SIDE-SHIFT CYLINDER	10-6
STEERING COLUMN	4-2
STEERING HYDRAULIC	4-6
STROBE LIGHT	10-12
T	
TILT CYLINDER	
⇒S/N C203A-2436Y	6-22
S/N C203A-2437Y⇒	6-24
TIRE AND WHEEL	
SOLID PNEUMATIC TYRE	10-10
TRACTION MOTOR	
⇒S/N C203A-2436Y	3-12
S/N C203A2437Y⇒	3-14
W	
WIRE HARNESS	
MAIN	
⇒S/N C203A-2436Y	2-16
S/N C203A-2437Y⇒	2-18

SECTION 1
FRAME

DESCRIPTION	PAGE
FRAME.....	1-2
LABELS.....	1-7
LOAD BACKREST EXTENSION.....	1-16
NON-SUSPENSION SEAT.....	1-8
OVERHEAD GUARD.....	1-14
SEMI-SUSPENSION SEAT.....	1-10
WITH ARM REST.....	1-12

FRAME (Figure 1-1)

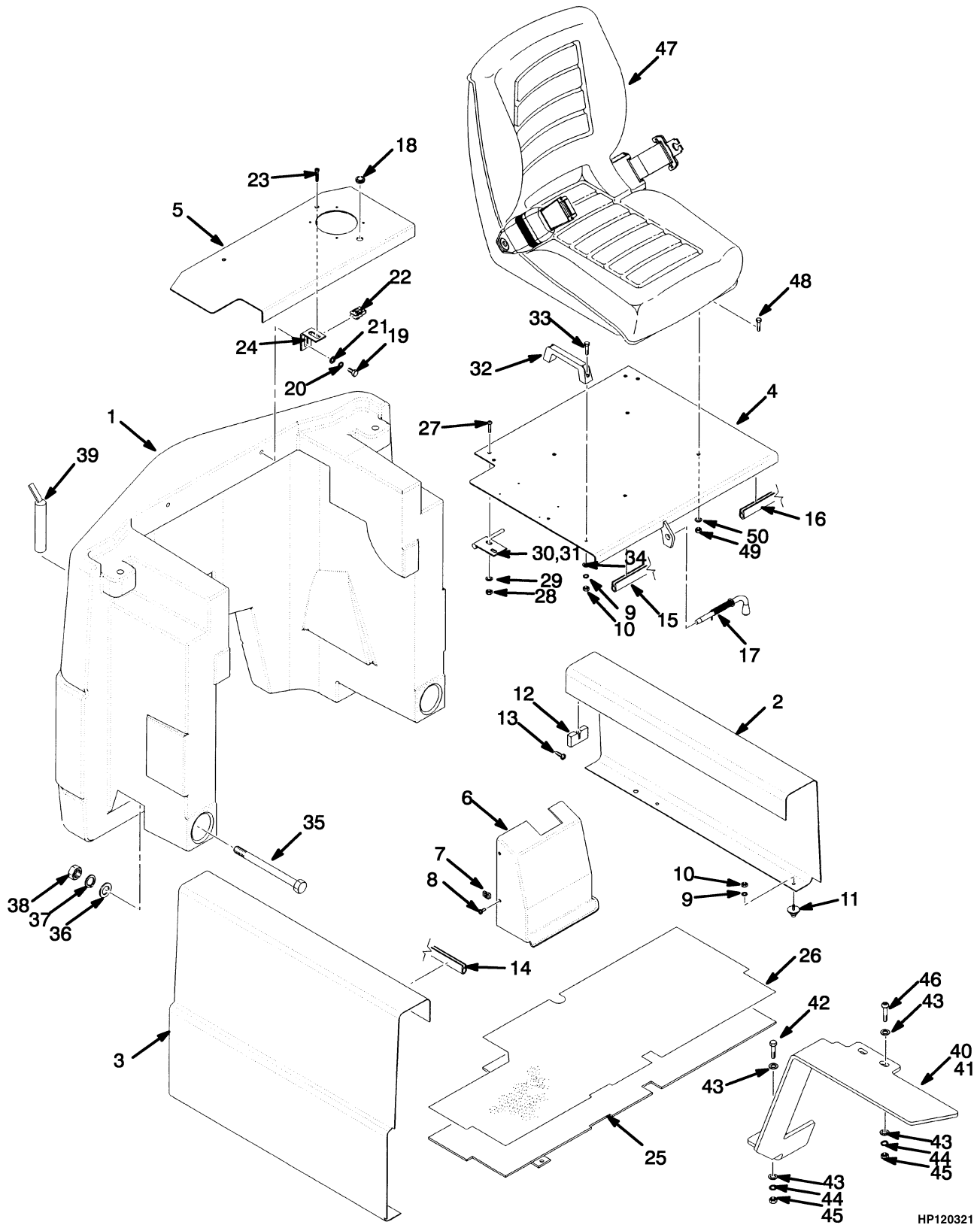

HP120321

FRAME

ITEM	PART NO.	DESCRIPTION	QTY
1	893412	Counterweight (A1.50XL)	1
1	893413	Counterweight (A1.25XL)	1
1	893414	Counterweight (A1.00XL)	1
2	878936	Cover (LH Side)	1
3	878935	Cover (RH Side)	1
4	a 878877	Hood	1
4	b 1499596	Hood	1
5	a 878879	Hood (Rear)	1
5	b 1502538	Hood (Rear)	1
6	893616	Cover (Three Function)	1
6	1493963	Cover (Four Function)	1
7	325182	Nut	3
8	302047	Screw	3
9	292680	Lockwasher	6
10	136687	Nut	6
11	363452	Buffer	4
12	363449	Moulding	4
13	134102	Screw	8
14	363594	Edge Trim	2
15	363593	Edge Trim	1
16	363592	Edge Trim	1
17	363599	Bolt	1
18	1361557	Grommet	1
19	292514	Capscrew	2
20	296420	Washer	4
21	292682	Lockwasher	4
22	269200	Nut	2
23	220395	Screw	2
24	1473620	Bracket	2
25	878894	Floorplate	1
26	878893	Floormat	1
27	296165	Capscrew	4
28	316835	Nut	4
29	320158	Washer	4
30	878883	Hinge (LH)	1
31	878884	Hinge (RH)	1
32	362030	Handle	2
33	292501	Capscrew	2
34	320156	Washer	2
35	292598	Capscrew	2
36	300750	Washer	2
37	292687	Lockwasher	2
38	292659	Nut	2
39	363509	Tow Pin	1
40	893509	Fender (Left)	1
41	893510	Fender (Right)	1
42	176640	Capscrew	2
43	320158	Washer	12
44	292681	Lockwasher	6
45	239503	Nut	4
46	296167	Capscrew	4

FRAME

ITEM	PART NO.	DESCRIPTION	QTY
47	1460231	Non-Suspension Seat (☞ Figure 1-3)	1
47	2041645	Semi-Suspension Seat (☞ Figure 1-4)	1
48	136681	Capscrew	4
49	316835	Nut	4
50	320158	Washer	4

FOOTNOTES:

a ⇒ S/N C203A-2436Y

b S/N C203A-2437Y ⇒

LABELS (Figure 1-2)

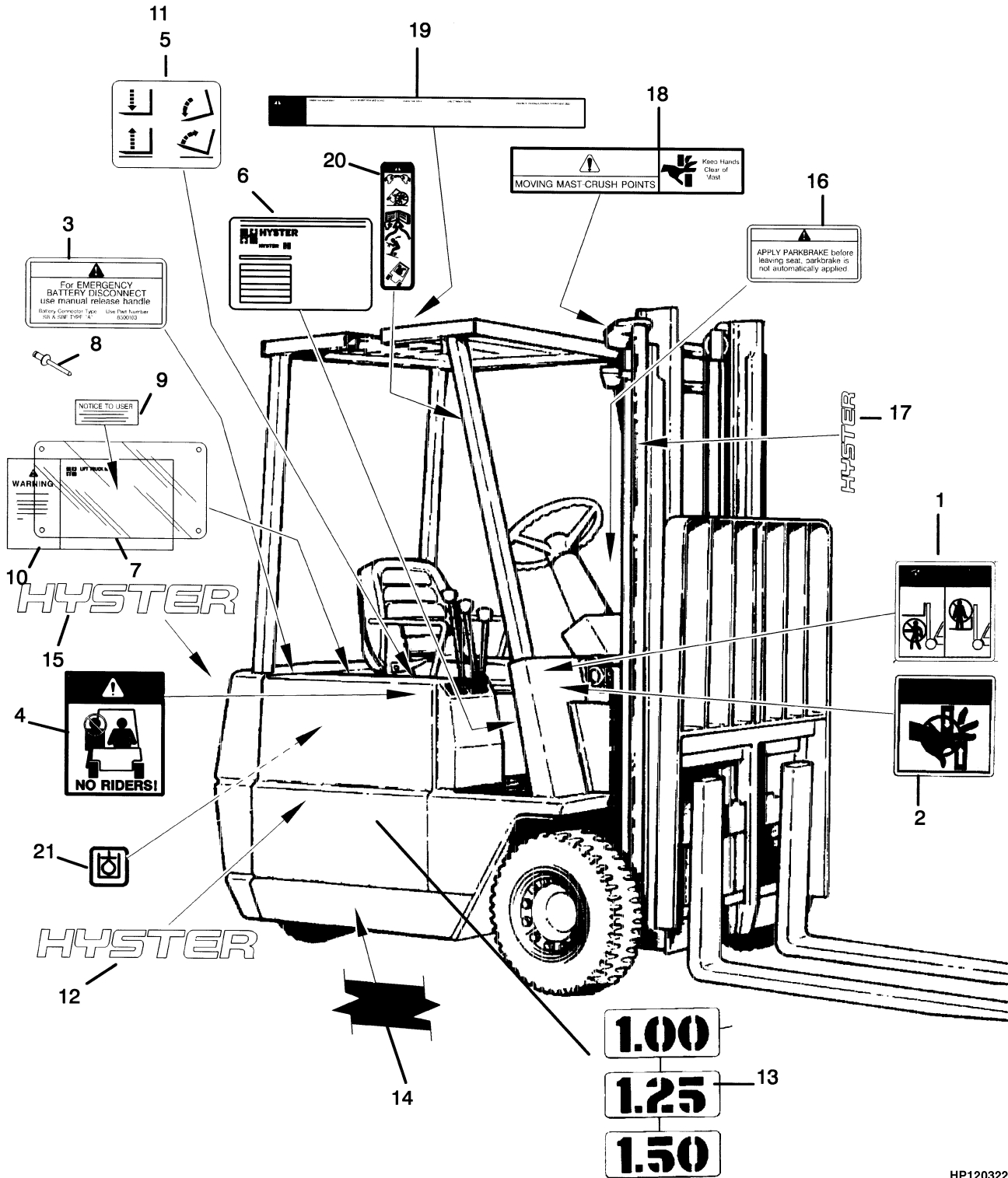

HP120322

LABELS

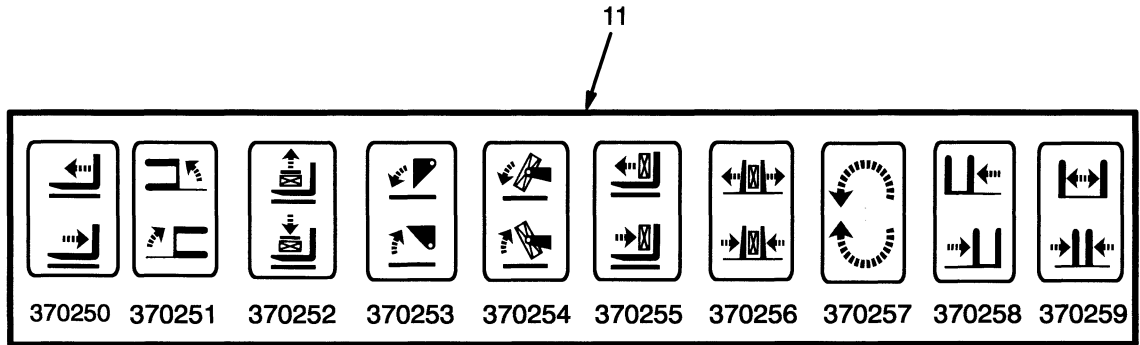

HP120323

ITEM	PART NO.	DESCRIPTION	QTY
1	1339830	Label (Mast Warning)	2
2	1339832	Label (Pinch Point)	2
3	8514049	Label (Battery Disconnect)	1
4	1339828	Label (No Riders)	2
5	369573	Label (Lift/Tilt).....	1
6	320037	Label (Patent Plate).....	1
7	389688	Cover	1
8	222023	Rivet.....	4
9	a	Nameplate	1
10	a	Nameplate	1
11	370250	Label (Auxiliary Function - Reach)	1
11	370251	Label (Auxiliary Function - Swing)	1
11	370252	Label (Auxiliary Function - Stabilizer)	1
11	370253	Label (Auxiliary Function - Dump/Scoop)	1
11	370254	Label (Auxiliary Function - Upender)	1
11	370255	Label (Auxiliary Function - Push/Pull).....	1
11	370256	Label (Auxiliary Function - Clamp)	1
11	370257	Label (Auxiliary Function - Rotate)	1
11	370258	Label (Auxiliary Function - Side-Shift)	1
11	370259	Label (Auxiliary Function - Fork Spreader)	1
12	1339674	Label (Hyster)	2
13	2026000	Label (Model 1.50).....	2
13	893535	Label (Model 1.00).....	2
13	893536	Label (Model 1.25).....	2
14	2013578	Strip	AR
15	1480394	Label (Hyster) (Counterweight).....	1
16	1357001	Label (Park Brake Warning).....	1
17	893534	Label (Hyster)	2
18	1343276	Label (Mast Warning)	1
19	1373909	Label (Operator Warning)	1
20	1359588	Label (Operator Restraint)	2
21	1385099	Label (Hydraulic Oil Fill).....	1

FOOTNOTES:

a Contact Your Local Hyster Dealer

NON-SUSPENSION SEAT (Figure 1-3)

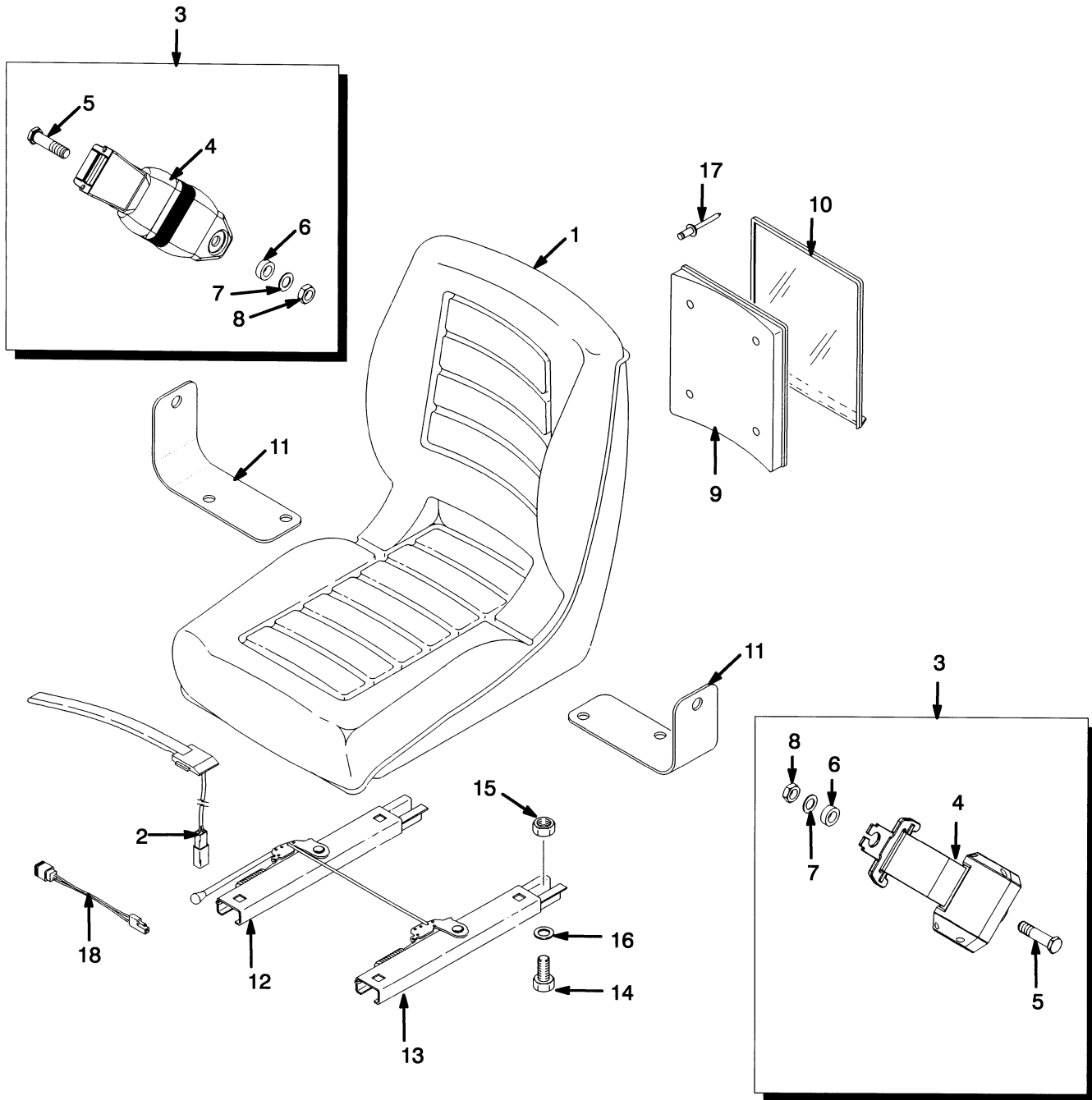

HP120324

NON-SUSPENSION SEAT

ITEM	PART NO.	DESCRIPTION	QTY
	1460231	Non-Suspension Seat.....	1
1	364911	Seat.....	1
2	2037311	Switch Assembly	1
3	1461081	Seat Belt Kit.....	1
4	Seat Belt	1
5	Screw	2
6	Washer.....	2
7	Washer.....	2
8	Nut	2
9	335988	Base	1
10	335991	Cover	1
11	1470175	Bracket	1
12	1470176	Seat Rail.....	1
13	1470177	Seat Rail.....	1
14	136681	Capscrew.....	4
15	316835	Nut	4
16	320158	Washer	4
17	Rivet.....	4
18	1460232	Jumper.....	1

SEMI-SUSPENSION SEAT (Figure 1-4)

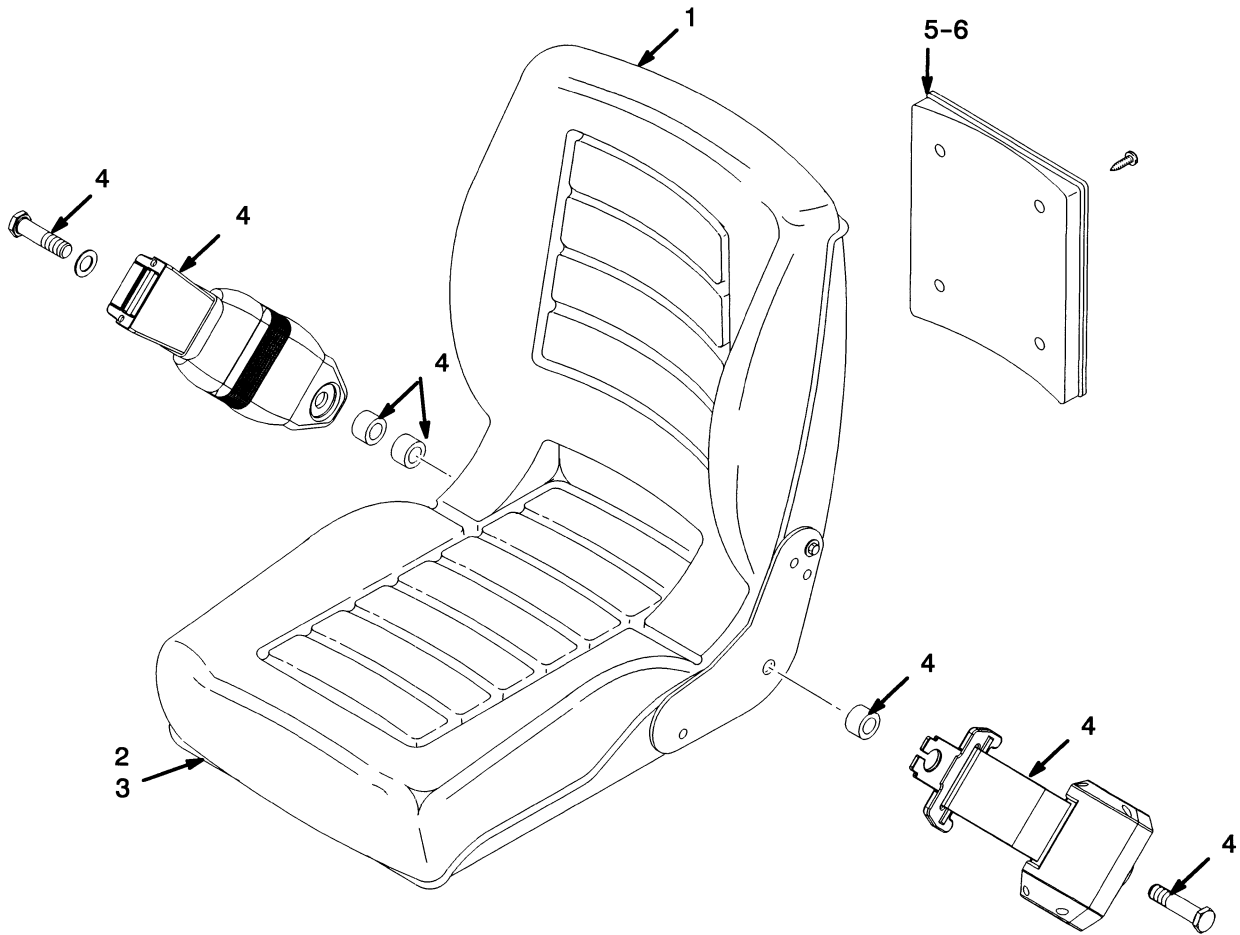

HP120325

SEMI-SUSPENSION SEAT

ITEM	PART NO.	DESCRIPTION	QTY
	2041645	Semi-Suspension Seat	1
1	1480403	Back Cushion	1
2	1480404	Seat Cushion (With Switch).....	1
3	a 1480405	Slider Kit	1
4	1461081	Seat Belt Kit.....	1
5	335989	Tube.....	1
6	335991	Cover	1

FOOTNOTES:

a Not Illustrated

**SEMI-SUSPENSION SEAT
WITH ARM REST**

ITEM	PART NO.	DESCRIPTION	QTY
	2051298	Semi-Suspension Seat	1
1	1480403	Back Cushion	1
2	1480404	Seat Cushion (With Switch).....	1
3	a 1480405	Slider Kit	1
4	1461081	Seat Belt Kit.....	1
5	335989	Tube.....	1
6	335991	Cover	1
7	1492278	Armrest Kit	1
	a 893818	Ground Wire	1

FOOTNOTES:

a Not Illustrated



Suggest:

For more complete manuals. Please go to the home page.

<https://www.ebooklibonline.com>

If the above button click is invalid. Please download this document first, and then click the above link to download the complete manual.

Thank you so much for reading

OVERHEAD GUARD (Figure 1-6)

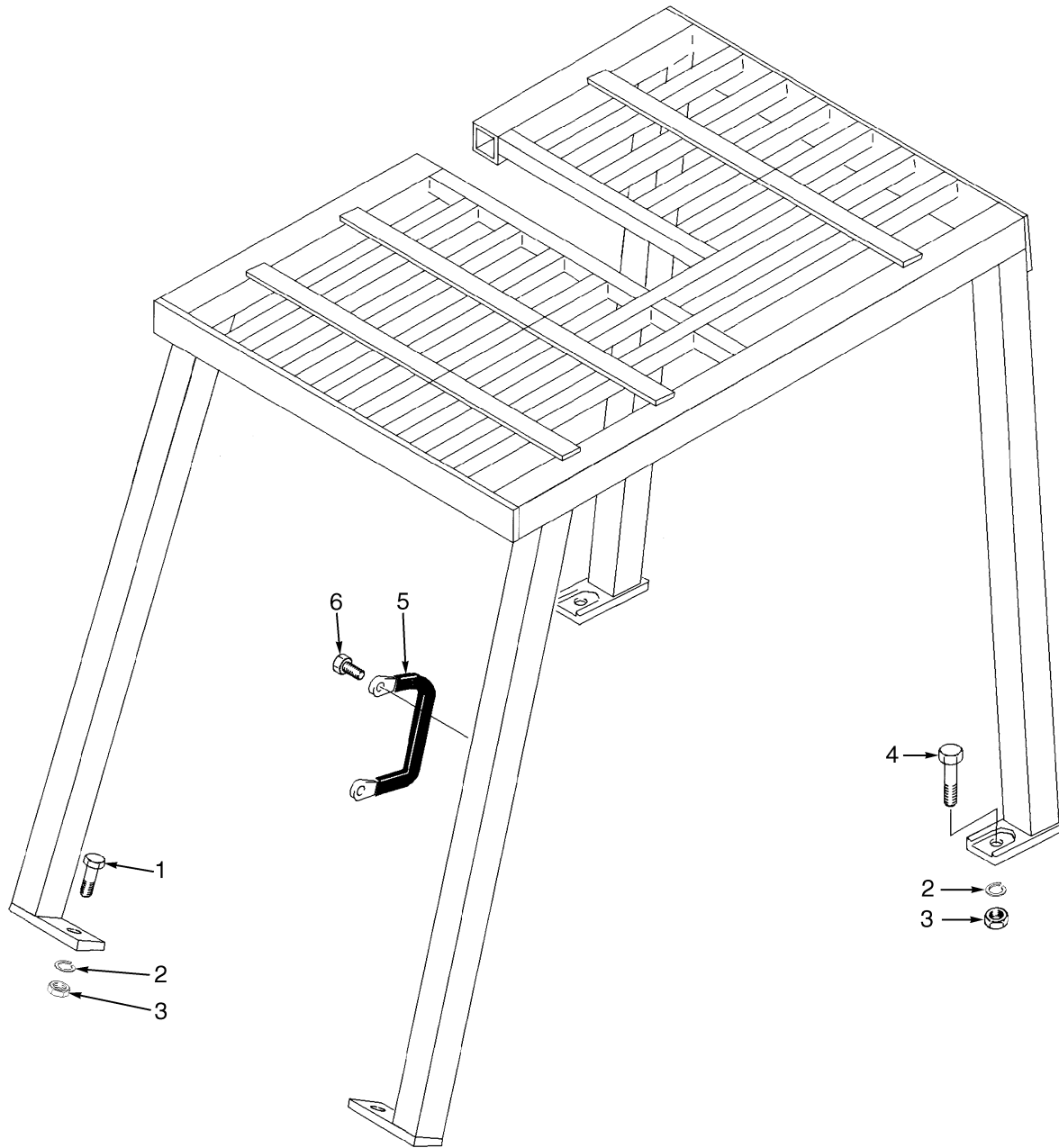

YP260288

OVERHEAD GUARD

ITEM	PART NO.	DESCRIPTION	QTY
	893538	Overhead Guard	1
1	292528	Capscrew	4
2	292683	Lockwasher	4
3	216877	Nut	4
4	292534	Capscrew	2
5	1343647	Handle	1
6	329067	Screw	2
	1363917	Plug	2

<https://www.ebooklibonline.com>

Hello dear friend!

Thank you very much for reading.

Enter the link into your browser.

The full manual is available for immediate download.

<https://www.ebooklibonline.com>