

YANMAR
SERVICE MANUAL

EXCAVATOR

MODEL *ViC*₃₀₋₂, *ViC*₃₅₋₂ (EP)

CONTENTS

CHAPTER 1

GENERAL CAUTIONS FOR MAINTENANCE WORK

1-1 Correct Work	1-1
1-2 Safety Precautions	1-1
1-3 Preparations	1-1
1-4 Cautions for Disassembly and Reassembly	1-1
1-5 Cautions for Removal and Installation of Hydraulic Equipment	1-2
1-6 Cautions for Removal and Installation of Hydraulic Piping	1-2
1-7 Cautions for Handling Seals	1-3
1-8 Correct Installation of Hydraulic Hose	1-3
1-9 Specifications of Hydraulic Hose	1-6
1-10 Air Release of Hydraulic Equipment	1-11

CHAPTER 2

TECHNICAL DATA

2-1 Specifications	2-1-1
2-2 Outline Drawing and Working Area	2-2-1
2-2-1 Canopy type	2-2-1
2-2-2 Cabin type	2-2-2
2-3 Weight List of Main Parts	2-3-1
2-4 Lifting Capacity List	2-4-1

CHAPTER 3

SERVICE STANDARDS

3-1 Machine Performance	3-1-1
3-2 Engine	3-2-1
3-3 Undercarriage	3-3-1
3-3-1 Rubber Crawler Specifications	3-3-1
3-3-2 Steel Crawler Specifications	3-3-2
3-3-3 Common Specifications of Steel & Rubber Crawlers	3-3-3
3-4 Controls	3-4-1
3-5 Hydraulic Equipment	3-5-1
3-5-1 Hydraulic Cylinders	3-5-1
3-6 Implement	3-6-1
3-6-1 Front Attachments	3-6-1
3-6-2 Blade Moving Device	3-6-3
3-6-3 Bucket Teeth	3-6-3
3-7 List of Tightening Torque	3-7-1
3-7-1 Machine	3-7-1
3-7-2 Engine	3-7-4
3-7-3 Tightening Torque for General Bolts and Nuts	3-7-4

CHAPTER 4

ENGINE

4-1 Measurement, Inspection and Adjustment	4-1-1
4-1-1 Measuring the Compression Pressure	4-1-1
4-1-2 Adjusting the Valve Clearance	4-1-2

4-1-3	Checking the V-belt Tension	4-1-3
4-1-4	Checking the Fuel Injection Valve	4-1-3
4-1-5	Checking and adjusting the Fuel Injection Timing	4-1-5
4-1-6	Adjusting the Maximum (or Minimum) Idling Speed	4-1-7
4-1-7	Checking the Cooling Water System and Radiator for Water Leakage	4-1-7
4-1-8	Checking the Sensors	4-1-8
4-2	Measurement Procedure, Service Data and Corrective Action	4-2-1
4-2-1	Cylinder Head	4-2-1
4-2-2	Cylinder Block	4-2-6
4-2-3	Valve Rocker Arm	4-2-8
4-2-4	Piston and Piston Rings	4-2-10
4-2-5	Connecting Rod	4-2-13
4-2-6	Cam shaft	4-2-16
4-2-7	Crank shaft	4-2-17
4-2-8	Gears	4-2-20
4-2-9	Trochoid Pump	4-2-21
4-3	Precautions for Reassembly	4-3-1
4-4	Fuel Injection System	4-4-1
4-4-1	Fuel Injection Pump	4-4-1
4-4-2	Fuel Injection Valve	4-4-2
4-4-3	Governor Mechanism	4-4-3
4-4-4	Specifications of Fuel Injection Pump	4-4-5
4-5	Electrical Equipment	4-5-1
4-5-1	Starter Motor	4-5-1
4-5-2	Alternator	4-5-3
4-5-3	Air Heater	4-5-4

CHAPTER 5

HYDRAULIC SYSTEM

5-1	Outline	5-1-1
5-1-1	Control Valve Operation	5-1-4
5-1-2	Additional Operation of Control Valve	5-1-6
5-2	Hydraulic Circuit Schematic	5-2-1
5-3	Circuit Operation	5-3-1
5-3-1	Boom	5-3-1
5-3-2	Arm	5-3-3
5-3-3	Bucket	5-3-5
5-3-4	Swing	5-3-7
5-3-5	Boom Swing	5-3-9
5-3-6	Blade	5-3-11
5-3-7	Travel	5-3-13
5-3-8	Non-Deviation Travel (with Boom, Arm, Bucket or Boom Swing Operation)	5-3-15
5-3-9	Simultaneous Operation of Boom Up and Arm Retract	5-3-17
5-3-10	Simultaneous Operation of Boom Up and Bucket	5-3-19
5-3-11	Simultaneous Operation of Arm and Bucket	5-3-21
5-3-12	Simultaneous Operation of Boom Up and Swing	5-3-23

<https://www.ebooklibonline.com>

Hello dear friend!

Thank you very much for reading.

Enter the link into your browser.

The full manual is available for immediate download.

<https://www.ebooklibonline.com>

5-3-13 Hydraulic P.T.O.	5-3-25
5-4 Pressure Adjustment.....	5-4-1
5-4-1 Relief Valves	5-4-1
5-4-2 Swing Brake Valve	5-4-3
5-4-3 Cut-Off Valve.....	5-4-4

CHAPTER 6 HYDRAULIC EQUIPMENT

6-1 Hydraulic Pump.....	6-1-1
6-2 Control Valve.....	6-2-1
6-3 Pilot Valve	6-3-1
6-4 Swing Motor	6-4-1
6-5 Travel Motor	6-5-1

CHAPTER 7 ADJUSTMENT AND REPAIR

7-1 Electrical Equipment of Machine and Engine.....	7-1-1
7-1-1 Parts Layout of Electrical Equipment	7-1-1
7-1-2 Monitor and Alarm Systems	7-1-3
7-1-3 Wiring Diagram.....	7-1-6
7-1-4 Circuit Description of Engine Start and Stop, and Battery Charging	7-1-7
7-1-5 Removal and Reinstallation of Engine	7-1-9
7-1-6 Removal and Reassembly of Starter Motor	7-1-16
7-1-7 Removal and Reinstallation of Fuel Injection Pump.....	7-1-17
7-2 Undercarriage	7-2-1
7-2-1 Outline	7-2-1
7-2-2 Major Parts	7-2-1
7-2-3 Points of Reassembly (Rubber Crawler Models)	7-2-2
7-2-4 Points of Reassembly (Steel Crawler Models).....	7-2-3
7-2-5 Removal and Reinstallation of Crawler	7-2-5
7-2-6 Removal and Reinstallation of Travel Motor	7-2-7
7-2-7 Disassembly and Reassembly of Idler	7-2-9
7-2-8 Disassembly and Reassembly of Track Roller.....	7-2-12
7-2-9 Disassembly and Reassembly of Carrier Roller	7-2-15
7-2-10 Installation of Floating Seal	7-2-17
7-2-11 Drawings of Jigs	7-2-18
7-3 Controls.....	7-3-1
7-3-1 Control Train.....	7-3-1
7-3-2 Mechanical Control Linkage	7-3-2
7-3-3 Adjustment of Travel Levers.....	7-3-4
7-3-4 Adjustment of Boom Swing Pedal	7-3-5
7-3-5 Adjustment of Blade Control Lever.....	7-3-5
7-3-6 Adjustment of Lock Lever.....	7-3-6
7-3-7 Adjustment Procedure of Travel Alarm Switch.....	7-3-7
7-3-8 Adjustment Procedure of P.T.O. Pedal	7-3-8
7-3-9 Adjustment Procedure of P.T.O. Pedal Lock.....	7-3-8
7-3-10 Adjustment of Accelerator Lever	7-3-9

7-4 Swing Bearing	7-4-1
7-5 Hydraulic Equipment	7-5-1
7-5-1 Removal and Reinstallation of Hydraulic Pump	7-5-1
7-5-2 Removal and Reinstallation of Control Valve	7-5-3
7-5-3 Removal and Reinstallation of Swing Motor.....	7-5-6
7-5-4 Removal and Reinstallation of Swivel Joint.....	7-5-8
7-5-5 Disassembly and Reassembly of Swivel Joint	7-5-11
7-5-6 Disassembly and Reassembly of Hydraulic Cylinders	7-5-14
7-5-7 Hydraulic Oil Tank.....	7-5-18
7-5-8 Piping Layout.....	7-5-25
7-6 Work Implements	7-6-1
7-6-1 Removal and Reinstallation of Work Implements.....	7-6-1
7-7 New Cabin.....	7-7-1
7-7-1 Cabin.....	7-7-1

CHAPTER 8

PERIODIC INSPECTION AND SERVICING

8-1 List of Periodic Inspection and Servicing.....	8-1
--	-----

CHAPTER 9

FUEL, LUBE OIL AND GREASE RECOMMENDED

9. Fuel, Lube Oil and Grease Recommended.....	9-1
---	-----

CHAPTER 10

TROUBLESHOOTING

10-1 Non-Breakdowns.....	10-1-1
10-1-1 Natural Release of Bucket.....	10-1-1
10-1-2 Discontinuous Arm Movement	10-1-1
10-1-3 Drifting of Upperstructure on Quick Travel Operation	10-1-2
10-1-4 Thermal Shock of Travel Motor	10-1-3
10-1-5 Elongation of Boom Swing Cylinder on 75 degrees Swing	10-1-4
10-1-6 Telescopic Motion of Boom Swing Cylinder with Lock Lever Set to Lock Position	10-1-5
10-1-7 Time Lag on Travel Speed Switching.....	10-1-6
10-1-8 Fluctuation in Oil Level of Hydraulic Oil Tank Due to Temperature Change.....	10-1-7
10-2 Troubleshooting	10-2-1
10-2-1 Machine and Engine.....	10-2-1
10-2-2 Electrical Equipment on Panel	10-2-22

CHAPTER 11

REFERENCE DATA

11-1 Specifications for Attachment.....	11-1
---	------

GENERAL CAUTIONS FOR MAINTENANCE WORK

1-1 Correct Work.....	1-1
1-2 Safety Precautions.....	1-1
1-3 Preparations	1-1
1-4 Cautions for Disassembly and Reassembly	1-1
1-5 Cautions for Removal and Installation of Hydraulic Equipment	1-2
1-6 Cautions for Removal and Installation of Hydraulic Piping	1-2
1-7 Cautions for Handling Seals	1-3
1-8 Correct Installation of Hydraulic Hose	1-3
1-9 Specifications of Hydraulic Hose	1-6
1-10 Air Release of Hydraulic Equipment	1-11

1. GENERAL CAUTIONS FOR MAINTENANCE WORK

1. General Cautions for Maintenance Work

1-1 Correct Work

Correct work means the quickest possible completion of according to the correct procedures and the specified standards.

It is important when conducting certain operations always to bear in mind the equipment, tools, gauges, materials, oil and grease, etc. that you must have ready, as well as items to be checked, adjusted, or disassembled, and cautions to watch out for.

1-2 Safety Precautions

- (1) Never attempt servicing while engine is running or immediately after stopping operation.
- (2) Wear work cloths, safety shoes and helmet.
- (3) Check the equipment and tools before use. Especially, be sure to check the crane, lifting equipment and tools.
- (4) When working together with other persons, allocate everyone's share of job, arrange the signals and act in concert with the other persons.
- (5) The operation of the crane and slinging work must be performed by qualified persons.
- (6) Do not enter or pass under the raised load.
- (7) Lift and support the massive parts by crane before removing the installation bolts.
- (8) Disconnect cables from battery before repairing the electric system.
- (9) Remove the battery when welding the machine.

1-3 Preparations

- (1) Check the service record of the machine. (That is, check how many months or hours the machine has been used since the preceding overhaul, what was the trouble then and what parts were replaced.)
- (2) Have all servicing tools ready, i.e., tools, measuring devices (which have received periodic maintenance), containers, oil & grease, etc.
- (3) Have the service literature (operation manual, parts catalog, etc.) ready.

1-4 Cautions for Disassembly and Reassembly

- (1) Clean the machine before disassembly.
- (2) Check and record the condition of the machine before disassembly :
 - Model, machine number, operation hours
 - Reasons for repair, history of repair
 - Contamination of filters
 - Fuel and oil condition
 - Damage to parts, etc.
- (3) Place alignment marks on the necessary parts to facilitate reassembly.
- (4) Clean all the removed parts and new replacement parts and put them in order.
- (5) Use new seals, split pins, etc. for reassembly.

1. GENERAL CAUTIONS FOR MAINTENANCE WORK

- (6) Keep the parts apt to be damaged by water or oil apart from the oily or wet parts.
e.g.: Electrical parts, rubber parts, V-belts, etc.
- (7) Use the jig for press-fitting the bearings, bushes and oil seals. When using a hammer, use a pad block.
- (8) Clean the joint surface of all parts and keep them free from dust.
- (9) Wind the sealing tape securely, leaving a space of one or two threads from the tip of the male screw. The tape should have an overlap of about 10 mm.

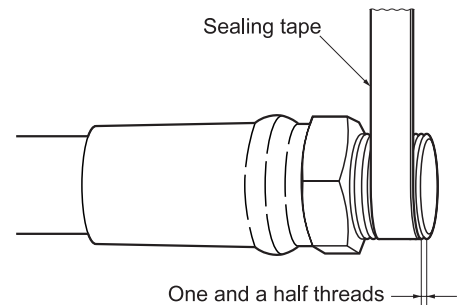

1-5 Cautions for Removal and Installation of Hydraulic Equipment

- (1) Check that the hydraulic oil temperature is low enough.
- (2) Release air from the hydraulic tank to prevent the hydraulic oil from flowing out.
- (3) Be sure to plug open the ends of hydraulic components to prevent dust from entering.
- (4) Be sure to wipe hydraulic oil from the hydraulic components so that it will not be mistaken for an oil leak.
- (5) Take care not to damage the plating on the cylinder rod.
- (6) Remove or install cylinders with rods fully retracted.
- (7) Be sure to release air after installing the hydraulic cylinders.
 - Run the engine at a low speed. Extend and retract the cylinders 4 to 5 times up to 50 to 100 mm from the end of the stroke. Then, fully extend and retract.
- (8) Be sure to pressurize the hydraulic tank after installing the hydraulic components (in the case of the sealed hydraulic tank). Otherwise, hydraulic pumps might suffer cavitation and their life will be shortened.
 - To pressurize the hydraulic tank, fully extend each cylinder and tighten the oil filter port plugs.

1-6 Cautions for Removal and Installation of Hydraulic Piping

- (1) Installation of hydraulic hose

Take care not to twist the hoses. (Judge whether or not the hose is twisted by the hose mark.) For hoses with a metal fitting, use two wrenches to prevent twisting.

Use one to fix the hose, and the other to tighten the fitting to the specified tightening torque. Carefully check that the hoses do not come in contact after tightening. If any contact is found, correct it or use tubes.

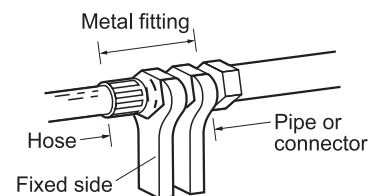

- (2) When installing hoses, first tighten to the specified torque and then loosen them a little. Then retighten to the specified torque.
 - Break in the installed parts before tightening (except those using seal tapes).
- (3) When installing pipes, turn the nuts more 1/4 to 1/2 turn after they reach the sharp torque rise point.
- (4) When installing or removing hoses, use two wrenches, one to fasten the hose and the other to tighten or loosen the hose to prevent twisting.
- (5) Check for oil leakage by applying max. pressure 5 to 6 times after attaching hydraulic hoses or pipes.

1. GENERAL CAUTIONS FOR MAINTENANCE WORK

1-7 Cautions for Handling Seals

(1) Clean out grooves of O-rings. Remove burrs or dust if any.

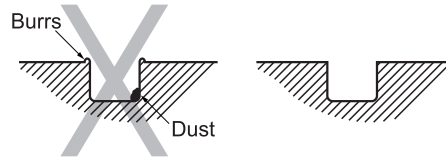

(2) Take care not to twist O-rings. Correct by your finger if it is twisted.

(3) Take care not to damage seals when inserting.

(4) Handling of floating seals :

- Completely wipe off all the oil from the O-ring and housing after detaching the floating seals.
- Before installing, apply a little gear oil to the matching face of the housing.
- Turn the seals two or three times after installation to break them in.

(5) Apply grease to the lip of the oil seals to prevent wear.

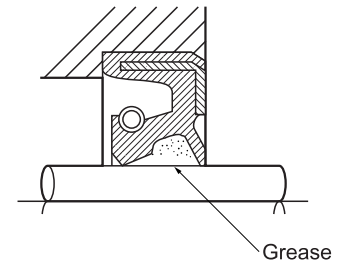

1-8 Correct Installation of Hydraulic Hose

In order to mount the hydraulic hose most effectively and economically, observe the following cautions.

(1) When a hose is used at the minimum bending radius, use elbows to avoid sharp bending.

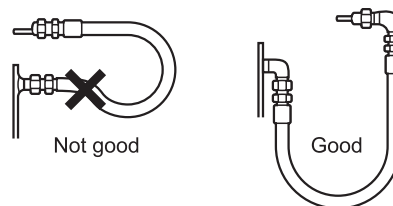

(2) To prevent twisting, the hose should be bent in the same direction as it moves.

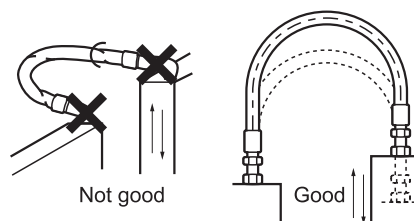

1. GENERAL CAUTIONS FOR MAINTENANCE WORK

- (3) When the hose is pressurized, the hose length varies slightly at the bend. Allow this change to occur and do not try to fasten the bend.

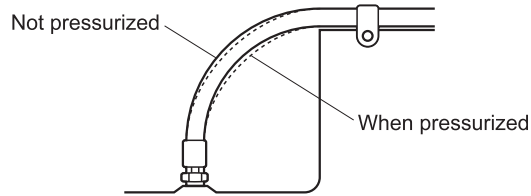

- (4) It is necessary for the hose to have ample slackness for elongation and contraction, because its length will change by +2 % to -4 % when used at high pressure.

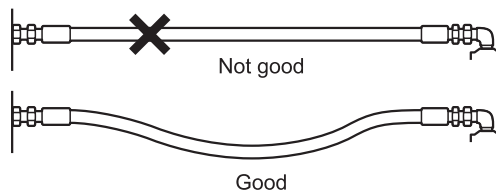

- (5) Use the proper adapters, not pipes, in order to reduce the number and length of joints and improve the external appearance.

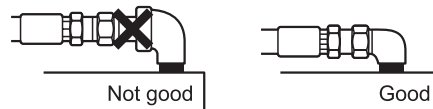

- (6) Use an elbow to prevent excessive twisting or bending of the hose.

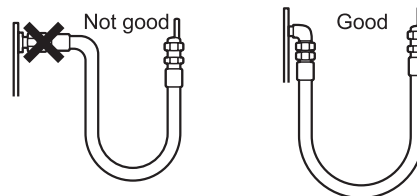

- (7) Use adapters to make the hose as straight as possible. The outside appearance can be improved by avoiding the use of hoses that are too long.

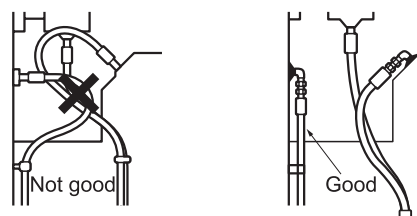

1. GENERAL CAUTIONS FOR MAINTENANCE WORK

- (8) The hose should be slightly longer than is absolutely necessary. The extra allows smoother movement of the hose and prevents sharp bending.

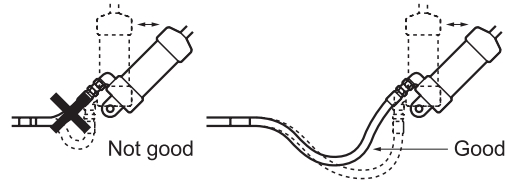

- (9) When a bent hose is attached to two different planes, fix as shown in the diagram to prevent twisting.

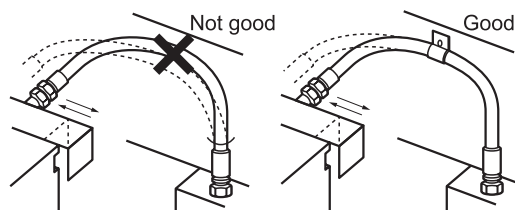

- (10) Use the marking on the hose as a guide to prevent twisting during installation. Twisting of metal fitting with union nuts should be with a wrench on the hexagonal parts.

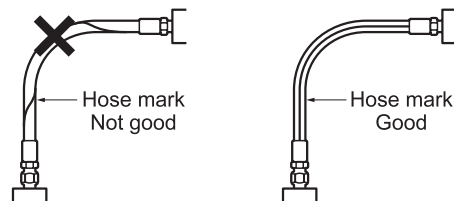

1. GENERAL CAUTIONS FOR MAINTENANCE WORK

1-9 Specifications of Hydraulic Hose

Two types of hydraulic hoses are used in Yanmar Construction Machinery : the standard parts specified in the Yanmar Industrial Standards (YIS) and special parts for the respective models. Specifications of the hydraulic hoses can be known by the code number or part descriptions as explained below. (For the parts number, please refer to our Parts Catalog.)

(1) Yanmar Standard Type

The part code consists of 11-digit numbers :

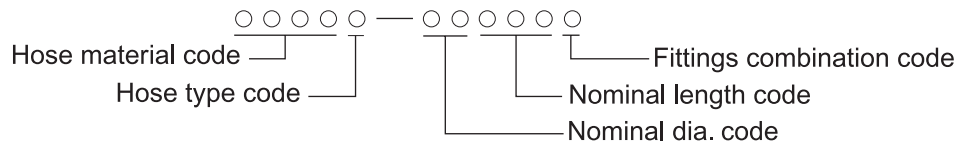

Description	Hose material	Type of hose		Hose dia.	Hose length	Combination of fittings	
Part code No.	○ ○ ○ ○	○	○ ○ ○ ○	○ ○ ○ ○	○		
Hose material	○ ○ ○ ○	○	○ ○ ○ ○	○ ○ ○ ○	○		
Rubber hose (High pressure type)	2320	1	(SAE J517,100R1)	02	Unit : cm	1	
			(SAE J517,100R2)	03		3	
		2	(SAE J517,100R2)	04		4	
			(SAE J517,100R2)	04		5	
Plastic hose (High pressure type)	2327	1	(SAE J517,100R7)	02		↑	4
			(SAE J517,100R7)	03			5
		2	(SAE J517,100R7)	04	7		
			(SAE J517,100R7)	04	7		
Rubber hose (Medium pressure type)	2325	1	(SAE J517,100R6)	02	↑		1
				03			4
				04			4
				05			4
				06		4	
				10		4	
				12		5	
14	5						

1. GENERAL CAUTIONS FOR MAINTENANCE WORK

1) Type of Hose (Hose Dia. & Recommended Working Pressure)

Type of hose	Hose dia.	Inner dia. [in. (mm)]	Outer dia. [in. (mm)]	Working pressure [PSI (MPa)]
1 (SAE J517, 100R1)	02	0.25 (6.3)	0.53 (13.5)	2489 (17.2)
	03	0.37 (9.5)	0.69 (17.5)	1991 (13.7)
	04	0.50 (12.7)	0.81 (20.6)	1564 (10.8)
2 (SAE J517,100R7)	02	0.25 (6.3)	0.59 (15.1)	4266 (29.4)
	03	0.37 (9.5)	0.75 (19.1)	3484 (24.0)
	04	0.50 (12.7)	0.87 (22.2)	2986 (20.6)
1 (SAE J517, 100R6)	02	0.25 (6.3)	0.49 (12.5)	2986 (20.6)
	03	0.37 (9.5)	0.65 (16.6)	2489 (17.2)
	04	0.50 (12.7)	0.81 (20.7)	1991 (13.7)
2 (SAE J517,100R7)	03	0.37 (9.5)	0.68 (17.2)	2986 (20.6)
	04	0.50 (12.7)	0.84 (21.4)	2986 (20.6)
1 (SAE J517,100R6)	02	0.25 (6.3)	0.50 (12.7)	427 (2.9)
	03	0.37 (9.5)	0.63 (15.9)	427 (2.9)
	04	0.50 (12.7)	0.78 (19.8)	427 (2.9)
	05	0.63 (15.9)	0.91 (23.0)	427 (2.9)
	06	0.75 (19.0)	1.25 (31.8)	427 (2.9)
	10	1.00 (25.4)	1.50 (38.1)	427 (2.9)
	12	1.25 (31.8)	1.75 (44.5)	427 (2.9)
14	1.50 (38.1)	2.04 (51.9)	427 (2.9)	

2) Total Length of Hose [Unit : in. (cm)]

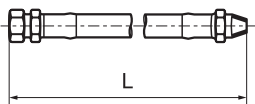

3 digit indication in cm.

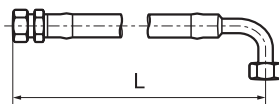

(Example) Nominal length 065 : Full length 25.6 in. (65 cm)

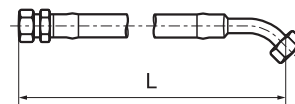

3) Hose Dia. (Unit : inch)

02....1/4"	05....5/8"	12....1 1/4"
03....3/8"	06....3/4"	14....1 1/2"
04....1/2"	10....1	

Note :

Please note that these code numbers are different from those for the equivalent diameters for special parts on the next page.

1. GENERAL CAUTIONS FOR MAINTENANCE WORK

4) Combination of Fitting

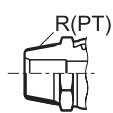
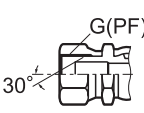
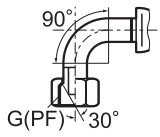
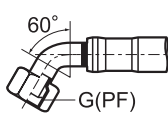
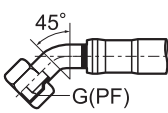
Code No.	Fitting type	A	B	C	D	E
1	A·B					
3	A·E					
4	B·B					
5	B·C					
6	B·E					
7	B·D					

(Example) Part code 2 3 2 0 2 - 0 3 0 8 5 5

Rubber hose, high pressure type _____

SAE J517, 100R2 _____

Nominal dia., 3 / 8" _____

Hose length, 33.5 in. (85 cm) _____

Straight pipe thread G (PF) with male 30 degrees seat and 90 degrees bent type. _____

Straight pipe thread G (PF) with male 30 degrees seat _____

List of pipe threads	
Symbol	Name
G (PF)	Straight pipe thread
R (PT)	Male taper pipe thread
Rc (PT)	Female taper pipe thread

Note :

All the hoses with fittings other than those listed above are special parts.



Suggest:

For more complete manuals. Please go to the home page.







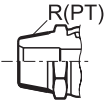
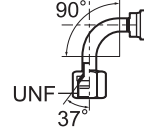

<https://www.ebooklibonline.com>

If the above button click is invalid. Please download this document first, and then click the above link to download the complete manual.

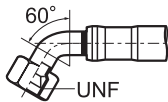
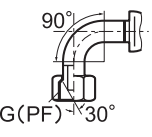
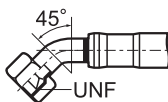
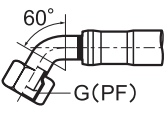
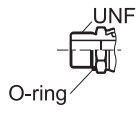
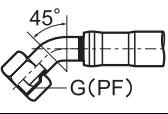
Thank you so much for reading

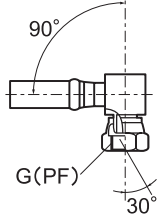
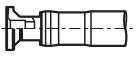
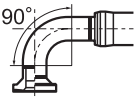
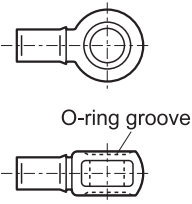
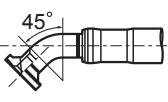
1. GENERAL CAUTIONS FOR MAINTENANCE WORK

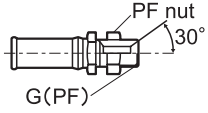
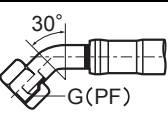
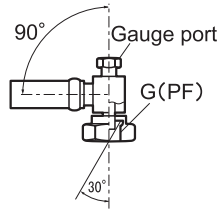
5 Combination of fitting

Fitting type	Code	Fitting type	Code
 <p>R(PT) Taper pipe thread R (PT)</p>	A	 <p>90° UNF 37° 90 degrees bent type. UNF thread with female 37 degrees seat</p>	P
 <p>G(PF) 30° Straight pipe thread G (PF) with male 30 degrees seat</p>	B	 <p>60° UNF 60 degrees bent type. UNF thread with female 37 degrees seat</p>	Q
 <p>90° G(PF) 30° 90 degrees bent type. Straight pipe thread G (PF) with male 30 degrees seat</p>	C	 <p>45° UNF 45 degrees bent type. UNF thread with female 37 degrees seat</p>	R
 <p>60° G(PF) 60 degrees bent type. Straight pipe thread G (PF) with male 30 degrees seat</p>	D	 <p>UNF O-ring UNF, thread with O-ring groove</p>	S
 <p>45° G(PF) 45 degrees bent type. Straight pipe thread G (PF) with male 30 degrees seat</p>	E	 <p>O-ring One-touch fitting (male)</p>	T
 <p>G(PF) 30° Straight pipe thread G (PF) with male 30 degrees seat</p>	F	 <p>90° G(PF) 30° 90 degrees elbow straight pipe thread male 30 degrees seat</p>	V
 <p>O-ring flange type</p>	G		
 <p>90° 90 degrees bent O-ring flange type</p>	H	 <p>O-ring groove Eyejoint with O-ring groove</p>	W
 <p>45° 45 degrees bent O-ring flange type</p>	J		
 <p>G(PF) 30° Straight pipe thread, female 30 degrees seat with O-ring groove</p>	K	 <p>PF nut 30° G(PF) Straight pipe thread with jam nut female 30 degrees seat</p>	X
 <p>30° G(PF) 30 degrees bent type. Straight pipe thread G (PF) with male 30 degrees seat</p>	L	 <p>90° Gauge port G(PF) 30° 90 degrees elbow straight pipe thread with gauge port plug male 30 degrees seat</p>	Z
 <p>NPTF Taper pipe thread NPTF</p>	M		
 <p>UNF 37° UNF, thread with female 37 degrees seat</p>	N	Without fitting	Y

Note :
According to the combination of bending or elbow fittings, some hoses require drawings or original hoses to locally manufacture.

1. GENERAL CAUTIONS FOR MAINTENANCE WORK

1-10 Air Release of Hydraulic Equipment

When operating the machine after disassembly or parts replacement of the hydraulic equipment, piping, etc., be sure to release air from the hydraulic system. This is necessary to prevent seizure and cavitation of the hydraulic equipment. If the air is left in the hydraulic system, the air is compressed or expanded depending on the load, having an adverse effect on the smooth operation of the hydraulic equipment and shortening the service life.

1. Air Release of Variable Displacement Piston Pumps

1) Put a Specified Quantity of Hydraulic Oil Into the Hydraulic Oil Tank.

Note :

1. Set the machine at the oil level check position.
2. Refer to the hydraulic oil supply procedure for how to put hydraulic oil into the tank.

2) Keep the Oil Supply Cap of the Hydraulic Oil Tank Removed.

3) Install the Air Bleeder Hose onto the Bleeder Valve and Loosen the Bleeder Valve Half a Turn. (Inside Diameter of the Hose : 0.20 in. [5 mm])

Note :

Since the top end of the bleeder valve is acting as a seat surface, the air is released only by loosening the bleeder valve.

4) Check that All the Air has been Released from the Bleeder Valve.

5) Tighten the Bleeder Valve, Remove the Hose and Install the Cap on the Bleeder Valve.

Bleeder valve	Width across flats : 0.40 in. (10 mm)
Tightening torque	3.61 to 5.06 ft·lbf (4.9 to 6.7 N·m)

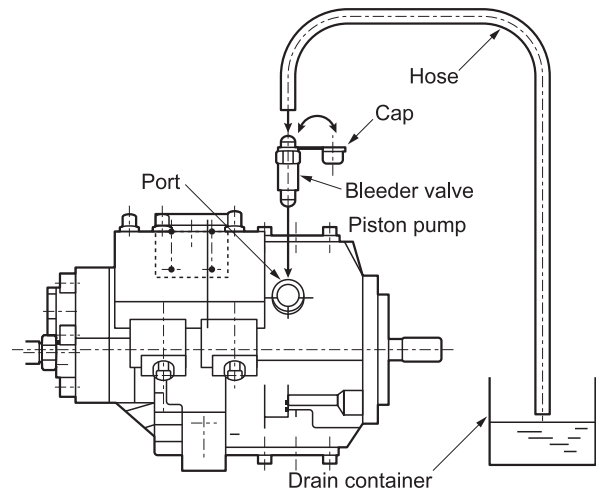

2. Air Release of Each Hydraulic Component

Run the engine at medium speed and activate the respective circuits for about 10 to 15 minutes.

3. Air Release of Hydraulic Cylinders

1) Set the Engine Speed at Low Idling Range.

2) Extend and Retract the Cylinder Up to 1.97 to 3.9 in. (50 to 100 mm) from Each Stroke End Slowly 4 or 5 Times.

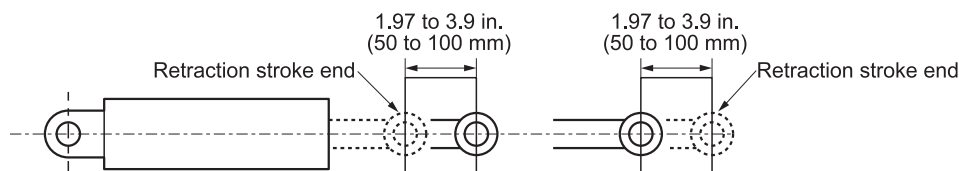

Note :

The extension and retraction stroke is up to 1.97 in. (50 mm) from each stroke end for the blade cylinder.

3) Then, Fully Extend and Retract the Cylinder 3 or 4 Times.

<https://www.ebooklibonline.com>

Hello dear friend!

Thank you very much for reading.

Enter the link into your browser.

The full manual is available for immediate download.

<https://www.ebooklibonline.com>