

YANMAR

SERVICE MANUAL

MARINE DIESEL ENGINE

MODELS

1GM10(C)
2GM20(F)(C)
3GM30(F)(C)
3HM35(F)(C)

Models

1 GM10(C) 2 GM20(F)(C) 3 GM30(F)(C) 3 HM35(F)(C)

A. Engine Model Name	0-1
B. Engine Model Name Plate and Clutch Model Name Plate	0-1
C. Cylinder Number	0-3

CHAPTER 1 GENERAL

1. Specifications	1-1
2. Principal Construction	1-4
3. Performance Curves	1-5
4. Features	1-9
5. Engine Cross-Sections	1-10
6. Dimensions	1-17
7. Piping Diagrams	1-24

CHAPTER 2 BASIC ENGINE

1. Cylinder Block	2-1
2. Cylinder Head	2-9
3. Piston	2-28
4. Connecting Rod	2-34
5. Crankshaft	2-38
6. Flywheel and Housing	2-49
7. Camshaft	2-53
8. Timing Gear	2-59

CHAPTER 3 FUEL SYSTEM

1. Fuel Injection System	3-1
2. Injection Pump	3-3
3. Injection Nozzle	3-25
4. Fuel Filter	3-29
5. Fuel Feed Pump	3-30
6. Fuel Tank (Option)	3-33

CHAPTER 4 GOVERNOR

1. Governor	4-1
2. Injection Limiter	4-9
3. No-Load Maximum Speed Limiter	4-11
4. Idling Adjuster	4-12
5. Engine Stop Lever	4-13

CHAPTER 5 INTAKE AND EXHAUST SYSTEM

1. Intake and Exhaust System	5-1
2. Intake Silencer	5-3
3. Exhaust System	5-4
4. Breather	5-6

CHAPTER 6 LUBRICATION SYSTEM

1. Lubrication System	6-1
2. Oil Pump	6-5
3. Oil Filter	6-9
4. Oil Pressure Regulator Valve	6-12
5. Oil Pressure Measurement	6-14

CHAPTER 7 DIRECT SEA-WATER COOLING SYSTEM

1. Cooling System	7-1
2. Water Pump	7-5
3. Thermostat	7-11
4. Anticorrosion Zink	7-14
5. Kingston Cock (Option)	7-16
6. Bilge Pump and Bilge Strainer (Option)	7-17

CHAPTER 8 FRESH WATER COOLING SYSTEM

1. Cooling System	8-1
2. Sea Water Pump	8-3
3. Fresh Water Pump	8-4
4. Heat Exchanger	8-7
5. Filler Cap and Subtank	8-11
6. Thermostat	8-13
7. Cooling Water Temperature Switch	8-16
8. Precautions	8-17

CHAPTER 9 MODIFYING THE COOLING SYSTEM

1. General	9-1
2. Disassembly of Sea Water-Cooled Engine	9-2
3. Assembling modified parts to the Fresh Water-Cooled Engine	9-7
4. Cautions When the Engine is Installed Inboard	9-12

CHAPTER 10 REDUCTION AND REVERSING GEAR

[A] For Engine Models 1GM10, 2GM20(F) and 3GM30(F)	
1. Construction	10-1
2. Shifting Device	10-7
3. Inspection and Servicing	10-14
4. Disassembly	10-19
5. Reassembly	10-24
[B] For Model 3GM35(F)	
1. Construction	10-29
2. Installation	10-33
3. Operation and Maintenance	10-34
4. Inspection and Servicing	10-35
5. Disassembly	10-40
6. Reassembly	10-44
[C] Marine Gear Models KM2P, KM3P and KM3V for Engine Models 1GM10, 2GM20(F) and 3GM30(F)	
1. Construction	10-50
2. Shifting Device	10-56
3. Inspection and Servicing	10-61
4. Disassembly	10-68
5. Reassembly	10-73
[D] V-drive Gear, Model KM3V	
1. Construction	10-77
2. Specifications	10-80
3. Power Transmission System	10-81
4. Cooling System (Sea-water Cooling Engine)	10-82
5. Piping Diagrams	10-85
6. Inspection and Servicing	10-90
7. Shim Adjustment for V-drive Gear Shaft, and Backlash Adjustment for V-drive Gear Shaft and Drive Gear	10-92
8. Disassembly	10-94
9. Reassembly	10-97

CHAPTER 11 REMOTE CONTROL SYSTEM

- 1. Construction 11-1
- 2. Clutch and Speed Regulator Remote Control 11-3
- 3. Engine Stop Remote Control 11-7

CHAPTER 12 ELECTRICAL SYSTEM

- 1. Electrical System 12-1
- 2. Battery 12-4
- 3. Starter Motor 12-7
- 4. Alternator Standard, 12V/55A 12-18
- 4A. Alternator Option, 12V/35A 12-28
- 5. Instrument Panel 12-37
- 6. Tachometer 12-43

CHAPTER 13 OPERATING INSTRUCTIONS

- 1. Fuel Oil and Lubricating Oil 13-1
- 2. Engine Operating Instructions 13-8
- 3. Troubleshooting and Repair 13-13

CHAPTER 14 DISASSEMBLY AND REASSEMBLY

(Direct Sea-Water Cooling Engine)

- 1. Disassembly and Reassembly Precautions 14-1
- 2. Disassembly and Reassembly Tools 14-2
- 3. Others 14-13
- 4. Disassembly 14-14
- 5. Reassembly 14-28

CHAPTER 15 DISASSEMBLY AND REASSEMBLY

(Fresh Water Cooling Engine)

- 1. Disassembly of Fresh Water-Cooled Engine 15-1
- 2. Reassembly of Fresh Water-Cooled Engine 15-11
- 3. Tightening Torque 15-21
- 4. Packing Supplement and Adhesive Application Point 15-24

<https://www.ebooklibonline.com>

Hello dear friend!

Thank you very much for reading.

Enter the link into your browser.

The full manual is available for immediate download.

<https://www.ebooklibonline.com>

A. Engine Model Name

B. Engine Model Name Plate and Clutch Model Name Plate

SM/GM(F)(C)-HM(F)(C)

A. Engine Model Name

The nomenclature of the New GM(F)/HM(F) series follows the order shown below.

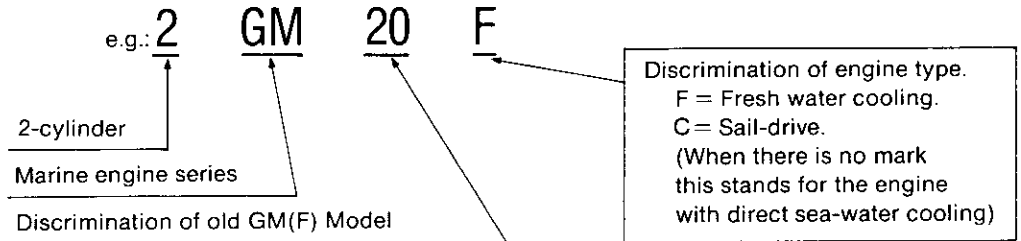

B. Engine Model Name Plate and Clutch Model Name Plate

To every engine model described in this manual, an engine model name plate and clutch model name plate are fitted as shown in the following figures. In addition, the engine serial number is stamped on the cylinder body. Specifications of the engine and clutch to be shipped are recorded and filed using the numbers marked on the engine model name plate and clutch model name plate.

The specifications or components of the engine or clutch may have been partially altered to improve performance, and the components involved may not necessarily be interchangeable. Therefore, when parts are ordered, please furnish the item description in the blank spaces shown in the figures, using the descriptions given on these plates.

B-1 Item descriptions on the model name plates and information to be forwarded to us

[Item descriptions on Model name plates]

[Information to be forwarded to us]

Engine model name plate

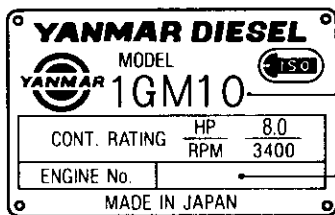

Your engine model

Your engine number

Clutch model name plate

GM-series

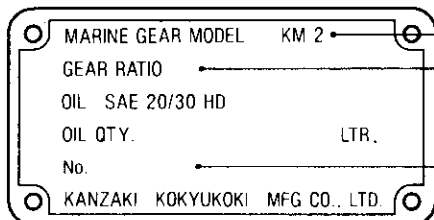

Your clutch model

Your clutch gear ratio

HM-series

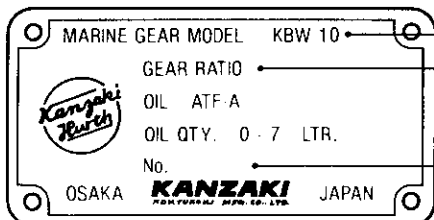

Your clutch number

B-2 Location of engine model name plate and clutch model name plate

B-2.1 1GM10(C)

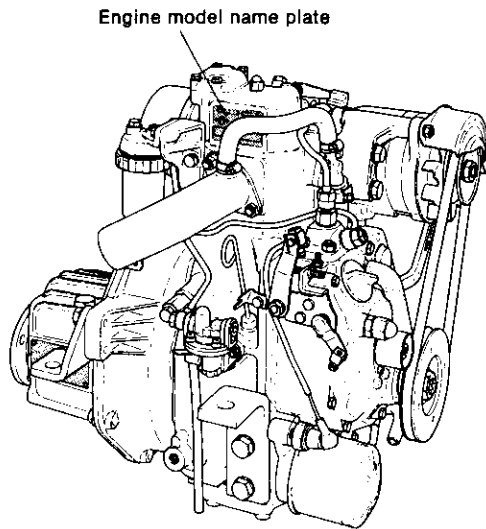

B-2.2 2GM20(F)(C), 3GM30(F)(C)

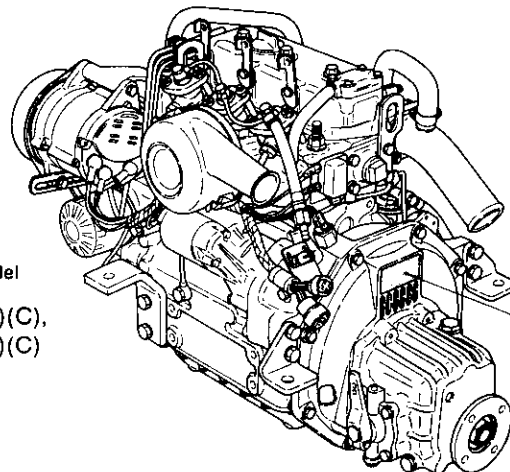
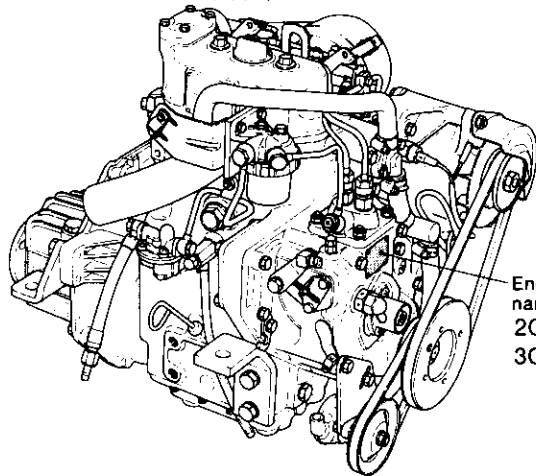

B-2.3 3HM35(F)(C)

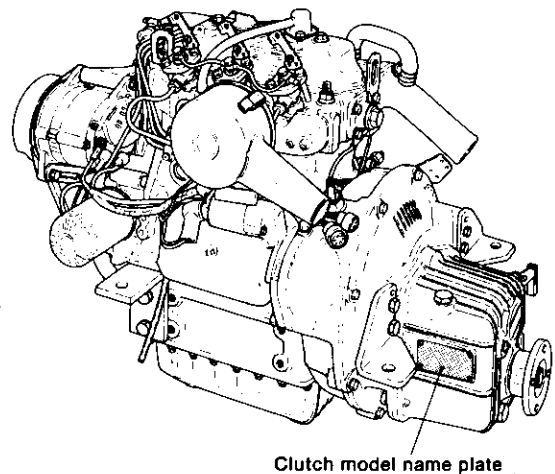
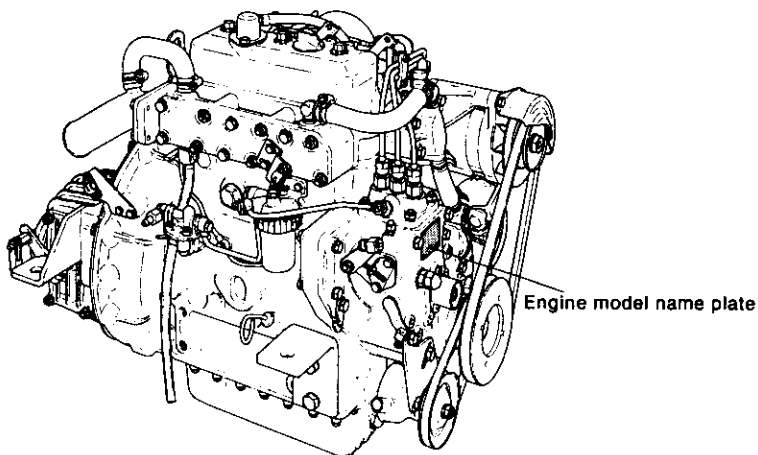

B-3 Location of stamped engine serial number

B-3.1 1GM10(C)

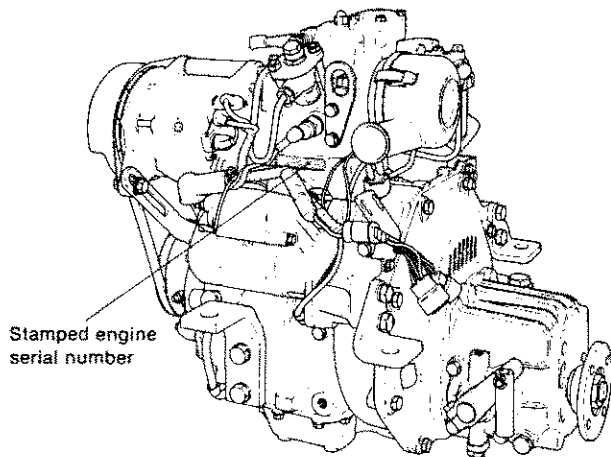

B-3.2 2GM20(F)(C), 3GM30(F)(C), 3HM35(F)(C)

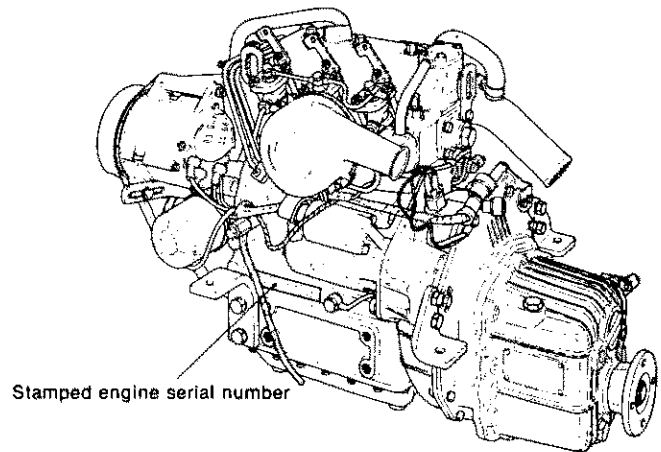

C. Cylinder Number

The cylinder numbers of the 2 cylinder engine and 3 cylinder engine described in this manual are designated as follows.

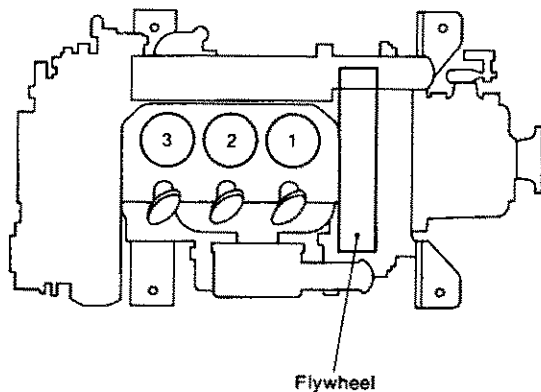

- (1) The sequence of cylinder numbers is given as No. 1, No. 2 and No. 3 starting from the flywheel side.
- (2) These cylinder numbers are consistently used for devices and parts connected with the cylinder head and valve moving mechanism. However, please note that items related to the fuel injection pump do not correspond to the numbering of the cylinders.

CHAPTER 1

GENERAL

1. Specifications	1-1
2. Principal Construction	1-4
3. Performance Curves	1-5
4. Features	1-9
5. Engine Cross-Sections	1-10
6. Dimensions	1-17
7. Piping Diagrams	1-24

1. Specifications

1-1. Direct Sea Water Cooling Type

Model		1GM10		2GM20		3GM30		3HM35						
Type		Vertical 4-cycle water cooled diesel engine												
Combustion chamber		Swirl pre-combustion chamber												
Number of cylinders		1		2		3		3						
Bore x stroke		mm (in.)		75 x 72 (2.95 x 2.83)						80 x 85 (3.15 x 3.35)				
Displacement		ℓ(in. ³)		0.318 (19.40)		0.636 (38.81)		0.954 (58.21)		1.282 (78.23)				
Continuous rating output (DIN6270A)	Output/Crankshaft speed	kW/rpm(HP/rpm)		5.9/3400(8.02/3400)		11.8/3400(16.0/3400)		17.7/3400(24.1/3400)		22.4/3200(30/3200)				
	Brake mean effective pressure	kgf/cm ² (lb/in. ²)		6.66 (94.71)		6.66 (94.71)		6.66 (94.71)		6.58 (93.57)				
	Piston speed	m/sec. (ft/sec.)		8.16 (26.77)		8.16 (26.77)		8.16 (26.77)		9.07 (29.76)				
One hour rating output (DIN6270B)	Output/crankshaft speed	kW/rpm(HP/rpm)		6.7/3600(9.1/3600)		13.4/3600(18.2/3600)		20.1/3600(27.3/3600)		25.4/3400(34/3400)				
	Brake mean effective pressure	kgf/cm ² (lb/in. ²)		7.07 (100.54)		7.07 (100.54)		7.07 (100.54)		7.02 (99.82)				
	Piston speed	m/sec. (ft/sec.)		8.64 (28.35)		8.64 (28.35)		8.64 (28.35)		9.63 (31.59)				
Compression ratio				23.0						24.8				
Fuel injection timing (FID)		degree		b.TDC15±1		b.TDC15±1		b.TDC18±1		b.TDC21±1				
Fuel injection pressure		kgf/cm ² (lb/in. ²)		170±5 (2347~2489)						160±5 (2204~2347)				
Main power take off		at Flywheel side												
Front power take off		at Crankshaft V-pulley side												
Direction of rotation	Crankshaft	Counter-clockwise viewed from stern												
	Propeller shaft (Ahead)	Clockwise viewed from stern												
Cooling system		Direct sea water cooling (rubber impeller water pump)												
Lubrication system		Complete enclosed forced lubrication												
Starting system		Electric and manual								Electric				
Clutch	Model	KM2C						KM3A			KBW10E			
	Type	Mechanical cone clutch with single stage for both ahead and astern												
	Reduction ratio (Ahead/A stern)	2.21/3.06		2.62/3.06		3.22/3.06		2.21/3.06		2.62/3.06		3.22/3.06		
	Propeller speed DIN A rating (Ahead/Astern)	rpm		1540/1113		1298/1113		1055/1113		1540/1113		1298/1113		
	Lubricating oil capacity	ℓ(in. ³)		0.25 (15.26)						0.3 (18.31)			0.7 (42.72)	
	Clutch weight	kg (lb.)		9.5 (20.95)						11.0 (24.26)			17.5 (38.58)	
Dimensions	Overall length	mm (in.)		547 (21.53)		638 (25.12)		735 (28.94)			786 (30.94)			
	Overall width	mm (in.)		410 (16.14)		455 (17.91)		455 (17.91)			485 (19.09)			
	Overall height	mm (in.)		485 (19.09)		495 (19.50)		495 (19.50)			617 (24.29)			
Lubricating oil capacity (rake angle 8°)	Total	ℓ(in. ³)		1.3 (79.33)		2.0 (122.05)		2.6 (158.65)			5.4 (329.51)			
	Effective	ℓ(in. ³)		0.6 (36.61)		1.3 (79.33)		1.6 (97.63)			2.7 (164.75)			
Engine weight with clutch (dry)		Kg (lb.)		76 (168)		106 (234)		130 (287)			158 (348)			

1-2. Fresh Water Cooling Type

Model		2GM20F	3GM30F			3HM35F				
Type		Vertical 4-cycle water cooled diesel engine								
Combustion chamber		Swirl pre-combustion chamber								
Number of cylinders		2			3					
Bore x stroke		mm (in.)		75 x 72 (2.95 x 2.83)			80 x 85 (3.15 x 3.35)			
Displacement		ℓ(in. ³)		0.636 (38.81)		0.954 (58.21)				
Continuous rating output (DIN 6270A)	Output/Crankshaft speed	kW/rpm(HP/rpm)		11.8/3400(16.0/3400)		17.7/3400(24.1/3400)				
	Brake mean effective pressure	kgf/cm ² (lb/in. ²)		6.66 (94.71)		6.58 (93.57)				
	Piston speed	m/sec. (ft/sec.)		8.16 (26.77)		9.07 (29.76)				
One hour rating output (DIN 6270B)	Output/Crankshaft speed	kW/rpm(HP/rpm)		13.4/3600(18.2/3600)		20.1/3600(27.3/3600)				
	Brake mean effective pressure	kgf/cm ² (lb/in. ²)		7.07 (100.54)		7.02 (99.82)				
	Piston speed	m/sec. (ft/sec.)		8.64 (28.35)		9.63 (31.59)				
Compression ratio				23.0		24.8				
Fuel injection timing (FID)		degree		b.TDC 15±1		b.TDC 18±1				
Fuel injection pressure		kgf/cm ² (lb/in. ²)		170±5 (2347~2489)		160±5 (2204~2347)				
Main power take off		at Flywheel side								
Front power take off		at Crankshaft V-pulley side								
Direction of rotation	Crankshaft	Counter-clockwise viewed from stern								
	Propeller shaft (Ahead)	Clockwise viewed from stern								
Cooling system		*Fresh water cooling with heat exchanger								
Lubrication system		Complete enclosed forced lubrication								
Starting system		Electric								
Clutch	Model	KM2-C			KM3A		KBW10E			
	Type	Mechanical cone clutch with single stage for both ahead and astern						Wet multi-disc mechanical type		
	Reduction ratio (Ahead/Astern)	2.21/3.06	2.62/3.06	3.22/3.06	2.36/3.16	2.61/3.16	3.20/3.16	2.14/2.50	2.83/2.50	
	Propeller speed DIN. A rating (Ahead/Astern)	rpm	1540/1113	1298/1113	1055/1113	1441/1076	1303/1076	1062/1076	1498/1280	1129/1280
	Lubricating oil capacity	ℓ(in. ³)	0.25 (15.26)			0.30 (18.31)		0.70 (42.72)		
	Clutch weight	kg (lb.)	9.5 (20.95)			11.0 (24.26)		17.5 (38.58)		
Dimensions	Overall length	mm (in.)		643 (25.31)		740 (29.13)		791 (31.14)		
	Overall width	mm (in.)		482 (19.00)		455 (17.91)		475 (18.70)		
	Overall height	mm (in.)		545 (21.46)		545 (21.46)		638 (25.12)		
Lubricating oil capacity (rake angle 8°)	Total	ℓ(in. ³)		2.0 (122.05)		2.6 (158.65)		5.4 (329.51)		
	Effective	ℓ(in. ³)		1.3 (79.33)		1.6 (97.63)		2.7 (164.75)		
Engine weight with clutch (dry)		kg (lb.)		114 (251)		138 (304)		167 (368)		

1-3. Direct Sea Water Colling Type (Sail-drive)

Model		1GM10C	2GM20C	3GM30C	3HM35C
Type		Vertical, 4-cycle water cooled diesel engine			
Combustion chamber		Swirl pre-combustion chamber			
Number of cylinders		1	2	3	
Bore x stroke		75 x 72 (2.95 x 2.83)			80 x 85 (3.15 x 3.35)
Displacement		ℓ (in. ³)		ℓ (in. ³)	
		0.318 (19.40)	0.636 (38.81)	0.954 (58.21)	1.282 (78.23)
Continuous rating output (DIN 6270A)	Output/Crankshaft speed	kW/rpm(HP/rpm)		kW/rpm(HP/rpm)	
	Brake mean effective pressure	kgf/cm ² (lb/in. ²)		kgf/cm ² (lb/in. ²)	
	Piston speed	m/sec. (ft/sec.)		m/sec. (ft/sec.)	
One hour rating output (DIN 6270B)	Output/Crankshaft speed	6.7/3600(9.1/3600)		13.4/3600(18.2/3600)	
	Brake mean effective pressure	kgf/cm ² (lb/in. ²)		kgf/cm ² (lb/in. ²)	
	Piston speed	m/sec. (ft/sec.)		m/sec. (ft/sec.)	
Compression ratio		23.0			24.8
Fuel injection timing (FID)		Degree		Degree	
		b.TDC 15±1		b.TDC 18±1	
Fuel injection pressure		kgf/cm ² (lb/in. ²)			kgf/cm ² (lb/in. ²)
		170±5 (2347~2489)			160±5 (2204~2347)
Main power take off		at Flywheel side			
Front power take off		at Crankshaft V-pulley side			
Direction of rotation	Crankshaft	Counter-clockwise viewed from stern			
	Propeller shaft (Sail-drive)	Counter-clockwise viewed from stern			
Cooling system		Direct sea water cooling (rubber impeller water pump)			
Lubrication system		Complete enclosed forced lubrication			
Starting system		Electric and manual			Electric
		SD 20			SD 30
Sail-drive	Model	SD 20			
	Reduction system	Constant mesh gear with dog clutch			
	Reduction ratio (Ahead/Astern)	2.64/2.64			
	Propeller speed DIN. A rating	rpm		rpm	
		1289		1212	
Lubricating capacity		ℓ (in. ³)		ℓ (in. ³)	
		2.2 (134.24)		2.2 (134.24)	
Dry weight		kg (lb.)			kg (lb.)
		30 (66)			32 (70)
Lubricating oil capacity (Engine side)	Total	ℓ (in. ³)		ℓ (in. ³)	
	Effective	ℓ (in. ³)		ℓ (in. ³)	
		1.3 (79.33)		2.0 (122.05)	
		0.6 (36.61)		1.3 (79.33)	
Engine weight with Sail-drive unit (Dry)		kg (lb.)		kg (lb.)	
		104 (229)		134 (295)	
				153 (337)	
				180 (397)	

2. Principal Construction

Engine model		1GM10	2GM20	3GM30	3HM35
Group	Part	Construction			
Engine block	Cylinder block	Integrally-cast water jacket and crankcase			
	Cylinder liner	Sleeveless			
	Main bearing	Metal housing type			
	Oil sump	Oil pan			
Intake and exhaust systems and valve mechanism	Cylinder head	Integrated type cylinders			
	Intake and exhaust valves	Poppet type, seat angle 90°			
	Exhaust manifold	—		Water-cooled type	Water-cooled type
	Exhaust silencer	Water-cooled mixing elbow type			
	Valve mechanism	Overhead valve push rod, rocker arm system			
	Intake silencer	Round polyurethane sound absorbing type			
Main moving elements	Crankshaft	Stamped forging			
	Flywheel	Attached to crankshaft by flange, with ring gear			
	Piston	Oval type			
	Piston pin	Floating type			
	Piston rings	2 compression rings, 1 oil ring			
Lubrication system	Oil pump	Trochoid pump			
	Oil filter	Full-flow cartridge type, paper element			
	Oil level gauge	Dipstick			
Cooling system	Water pump	Rubber impeller type			
	Thermostat	Wax pellet type			
Fuel system	Fuel injection pump	YPFR-0707-1	YPFR-0707-2	YPFR-0707-3	
	Fuel injection valve	Throttle valve, OSDYD1			
	Fuel feed pump	Mechanical type			
	Fuel strainer	Filter paper			
Governor	Governor	Centrifugal all-speed mechanical type			
Starting system	Electric	Pinion ring gear type starter motor			
	Manual	Camshaft starting			—
Electrical system	Charger	Alternator (with built-in IC regulator)			
Reduction reversing	Reduction gear	Helical gear constant-mesh system			
Clutch system	Clutch	Servo-cone type			Wet multi-disc mechanical type

Fresh-water cooling system (2GM20F, 3GM30F and 3HM35F)

Cooling system	Sea water pump	Rubber impeller type
	Fresh water pump	Centrifugal type
	Thermostat	Wax pellet type
	Heat exchanger	Multi-tube type

3. Performance Curves

3-1. 1GM10(C)

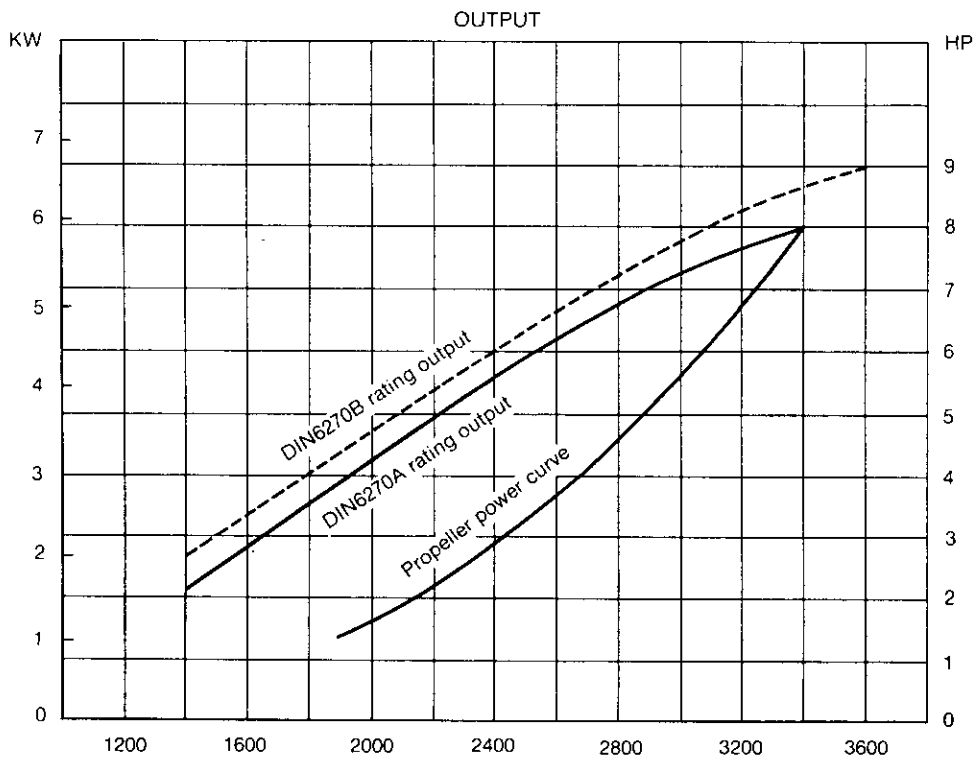
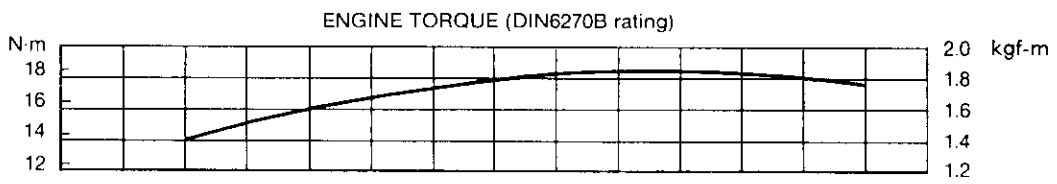
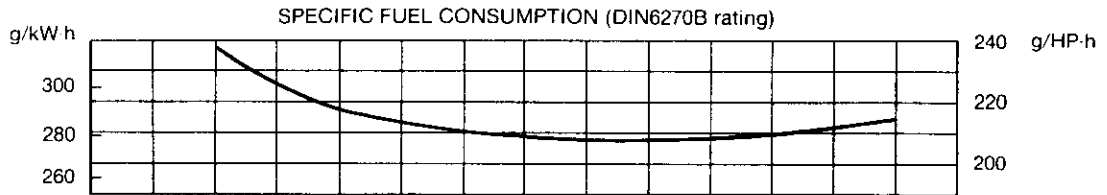

SPEED OF CRANKSHAFT: rpm
THE ENGINE FLYWHEEL OUTPUT IS APPROX 3% HIGHER.

NOTE: These curves show the average performance of respective engine in test operation at our plant.

3-2 2GM20(F)(C)

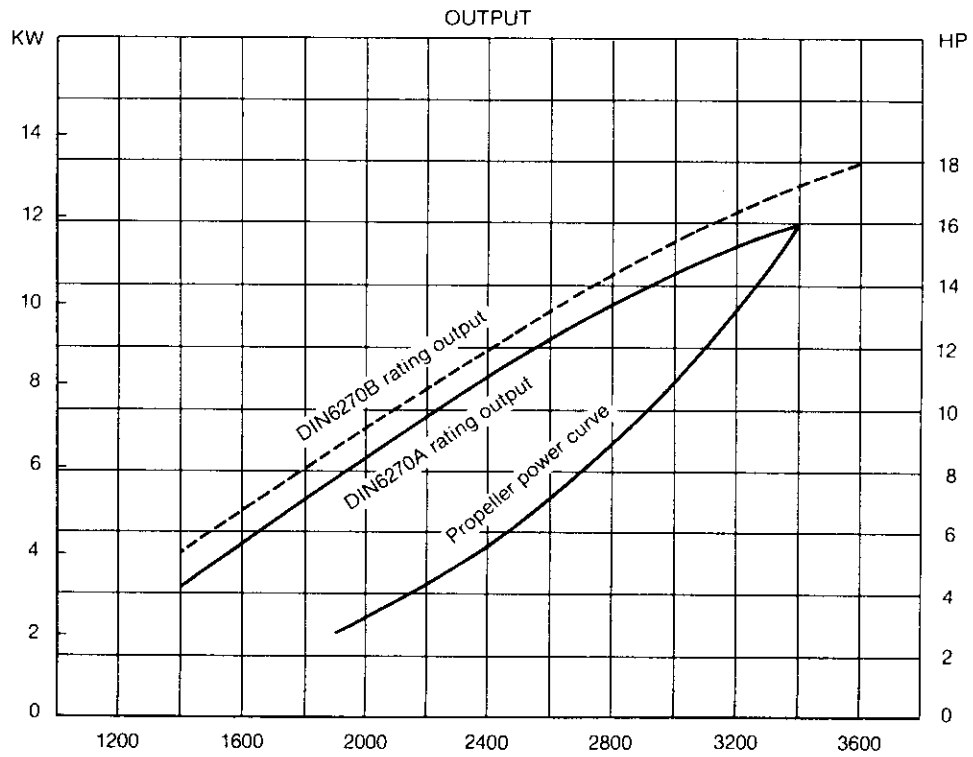
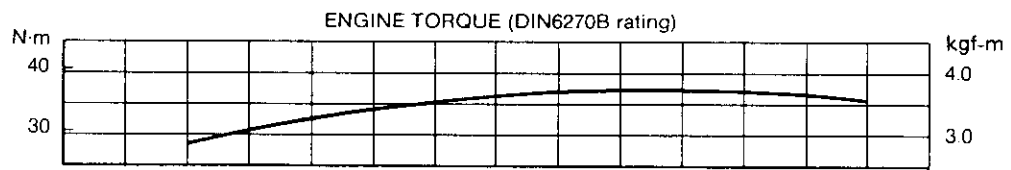
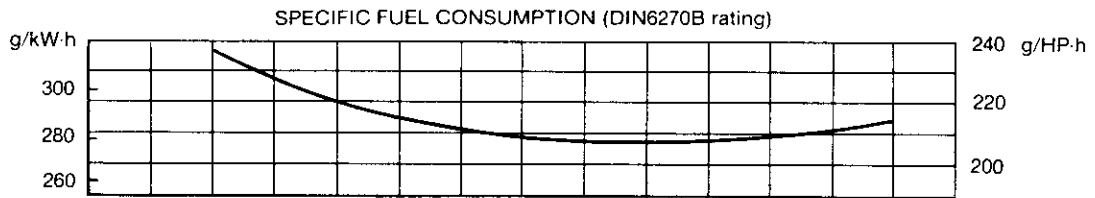

SPEED OF CRANKSHAFT: rpm
THE ENGINE FLYWHEEL OUTPUT IS APPROX 3% HIGHER.

NOTE: These curves show the average performance of respective engine in test operation at our plant.

3-3 3GM30(F)(C)

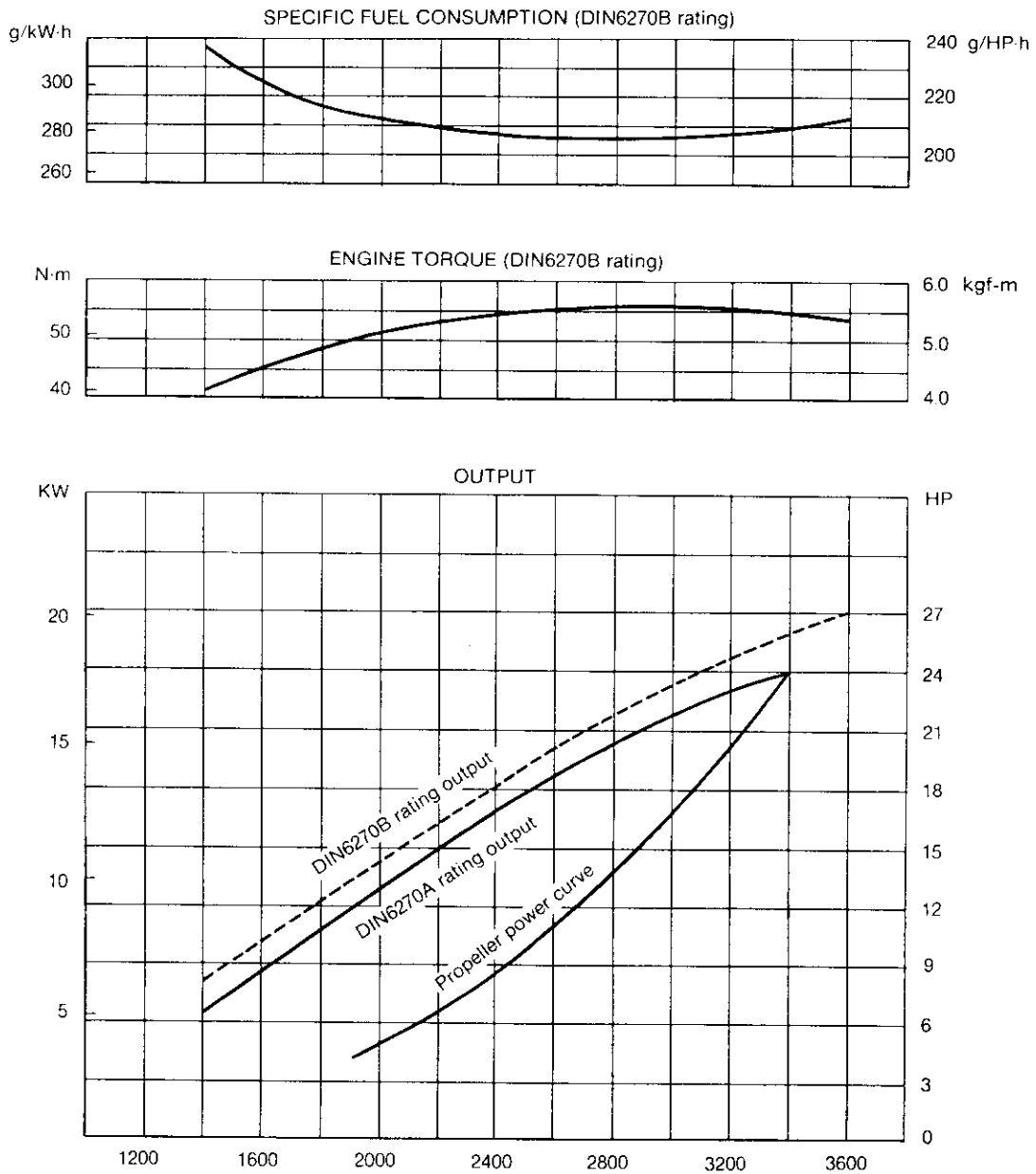

SPEED OF CRANKSHAFT: rpm
THE ENGINE FLYWHEEL OUTPUT IS APPROX 3% HIGHER.

NOTE: These curves show the average performance of respective engine in test operation at our plant.

3-4 3HM35(F)(C)

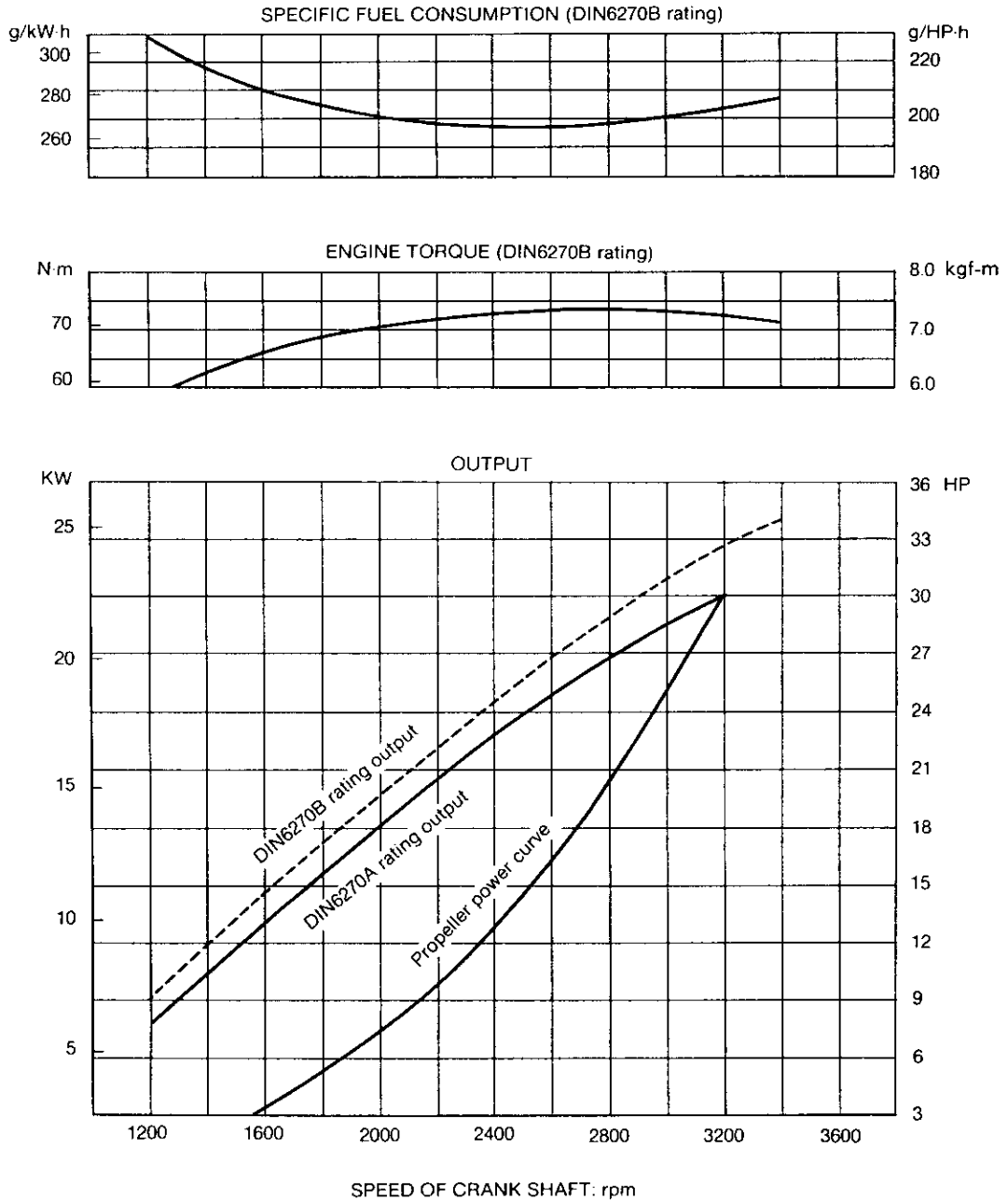

THE ENGINE FLYWHEEL OUTPUT IS APPROX 3% HIGHER

NOTE: These curves show the average performance of respective engine in test operation at our plant.

4. Features

4-1 Superior combustion performance

The unique Yanmar swirl precombustion chamber and new cooling system display superior combustion performance in all types of operation. Low-speed, low-load combustion performance, especially demanded for marine applications, is also superb, and stable performance is maintained over a wide range of speeds. Since starting characteristics are also excellent and warm-up is fast, full engine performance can be obtained within a short time.

4-2 Low operating costs

Excellent combustion and low friction reduce fuel costs, while the optimized piston shape ring configuration and improved cooling system reduce oil consumption. Continuous operating time has been extended and operating costs reduced through improved durability.

4-3 Compact, lightweight

The cylinder head is the integrally-cast type, and the crankshaft is the housing type. Minimum weight has been pursued for each engine part, and a reduction reversing gear employing a special new mechanism has been incorporated to obtain revolutionary engine lightness.

4-4 Long term continuous operation

Improved durability has been achieved by adopting special construction and materials for main moving parts and the valve mechanism, which are the areas most subject to trouble in high-speed engines. Moreover, a bypass system with a thermostat maintains the cooling water at a stable high temperature, resulting in reduced cylinder liner and piston ring wear, reduced thermal load around the combustion chamber, and substantially improved durability. Long-term continuous operation is possible by correct operation and proper attention to fuel and lubricating oil.

4-5 Low vibration

Vibration has been reduced by minimizing the weights of the pistons, connecting rods, and other sources of vibration, stringent weight management at assembly, and balancing of the flywheel, V-pulley, etc. Vibration has also been suppressed through the adoption of a special cylinder block rib construction and improved rigidity. Rubber shock mounts are available when the engine is to be used under conditions which may lead to severe vibration.

4-6 Quiet operation

Intake and exhaust noises have been lowered by adopting an intake silencer, water-cooled exhaust manifold and water mixing elbow type exhaust system.

The precombustion chamber system and semi-throttle type injection valve suppress combustion noise substantially.

Moreover, gear noise has been reduced by the use of helical gears around the gear train and clutch gear, and by the buffering effect of a damper disc.

In addition, noise prevention measures have also been taken at the control valve mechanism and other parts.

4-7 Superior matching to the hull

- (1) Four-point support engine installation feet make installation easy.
- (2) Mist intake system prevents contamination of the engine room.
- (3) Since the fuel pump is mounted on the engine, the fuel tank can be installed anywhere.
- (4) Water-cooled manifold prevents a rise in the engine room temperature.
- (5) Independent type instrument panel can be installed wherever it is easiest to see.
- (6) Speed, clutch forward and reverse, and engine stop can all be remotely controlled.
- (7) The use of rubber and vinyl hoses for ship interior piping not only facilitates piping work, but also eliminates brazing faults caused by vibration.
- (8) Electric type bilge pump is available as an option.

4-8 Easy to operate

- (1) Cooling water temperature switch and lubricating oil pressure switch are provided, and alarm lamps and buzzer are mounted on the instrument panel.
- (2) Manual starting handle permits manual starting.
(Except model 3HM35(C) and fresh water cooling type)
- (3) Positive clutch engagement and disengagement; propeller shaft does not rotate when clutch is placed in neutral position.

5. Engine Cross-Sections

5-1 1GM10

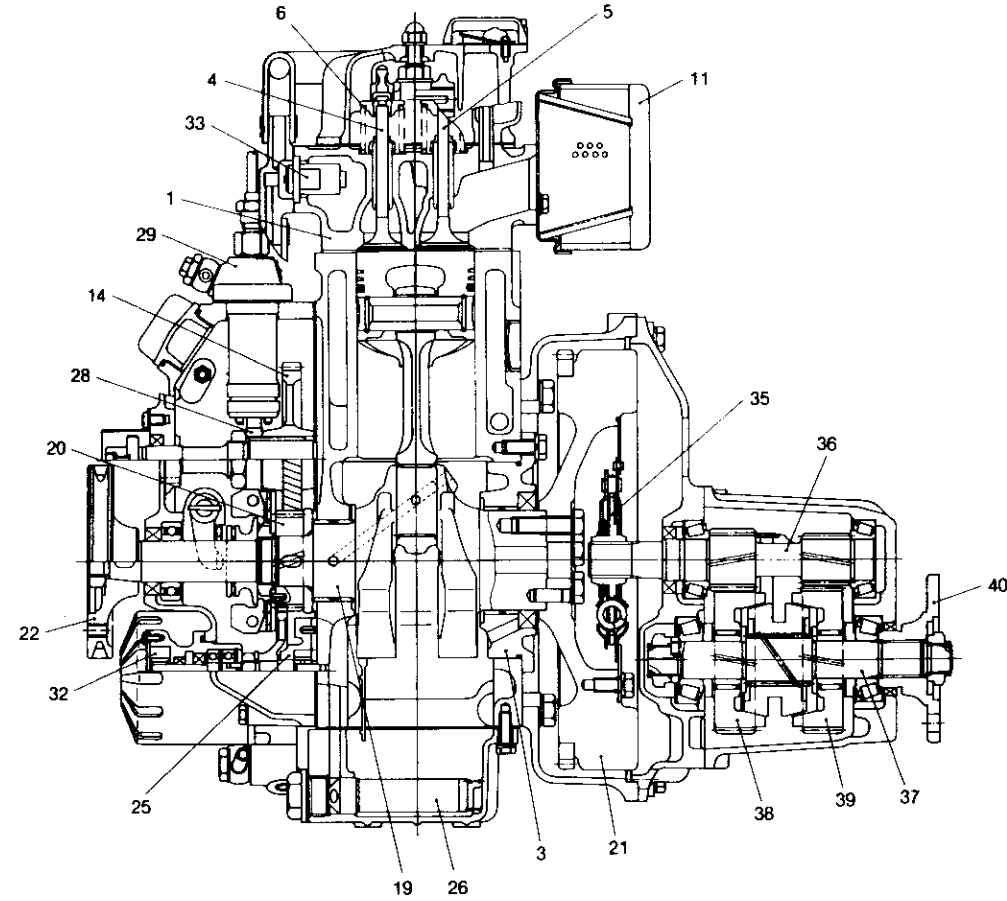
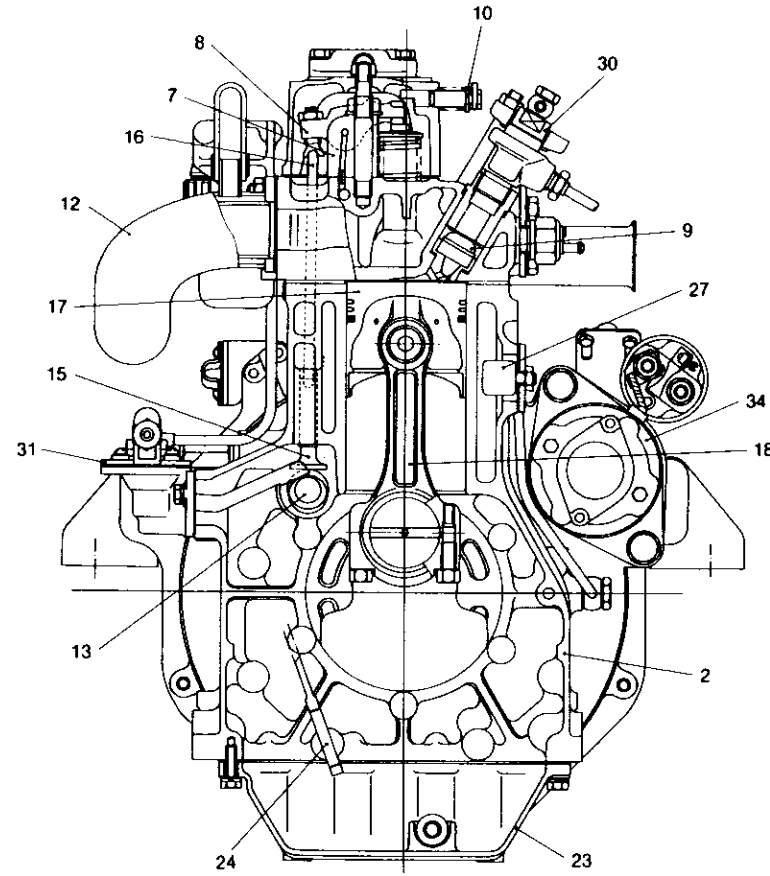

- 1. Cylinder head
- 2. Cylinder body
- 3. Main bearing housing
- 4. Exhaust valve
- 5. Intake valve
- 6. Valve spring
- 7. Valve rocker arm support
- 8. Valve rocker arm
- 9. Precombustion chamber
- 10. Decompression lever

- 11. Intake silencer
- 12. Mixing elbow
- 13. Camshaft
- 14. Camshaft gear
- 15. Tappet
- 16. Push rod
- 17. Piston
- 18. Connecting rod
- 19. Crankshaft
- 20. Crankshaft gear

- 21. Flywheel
- 22. Crankshaft V-pulley
- 23. Oil pan
- 24. Dipstick
- 25. Lubricating oil pump
- 26. Lubricating oil inlet pipe
- 27. Anticorrosion zinc
- 28. Fuel injection pump cam
- 29. Fuel injection pump
- 30. Fuel injection nozzle

- 31. Fuel feed pump
- 32. Cooling water pump
- 33. Thermostat
- 34. Starter motor
- 35. Damper disc
- 36. Input shaft
- 37. Output shaft
- 38. Forward large gear
- 39. Reverse large gear
- 40. Output shaft coupling

5-2 2GM20

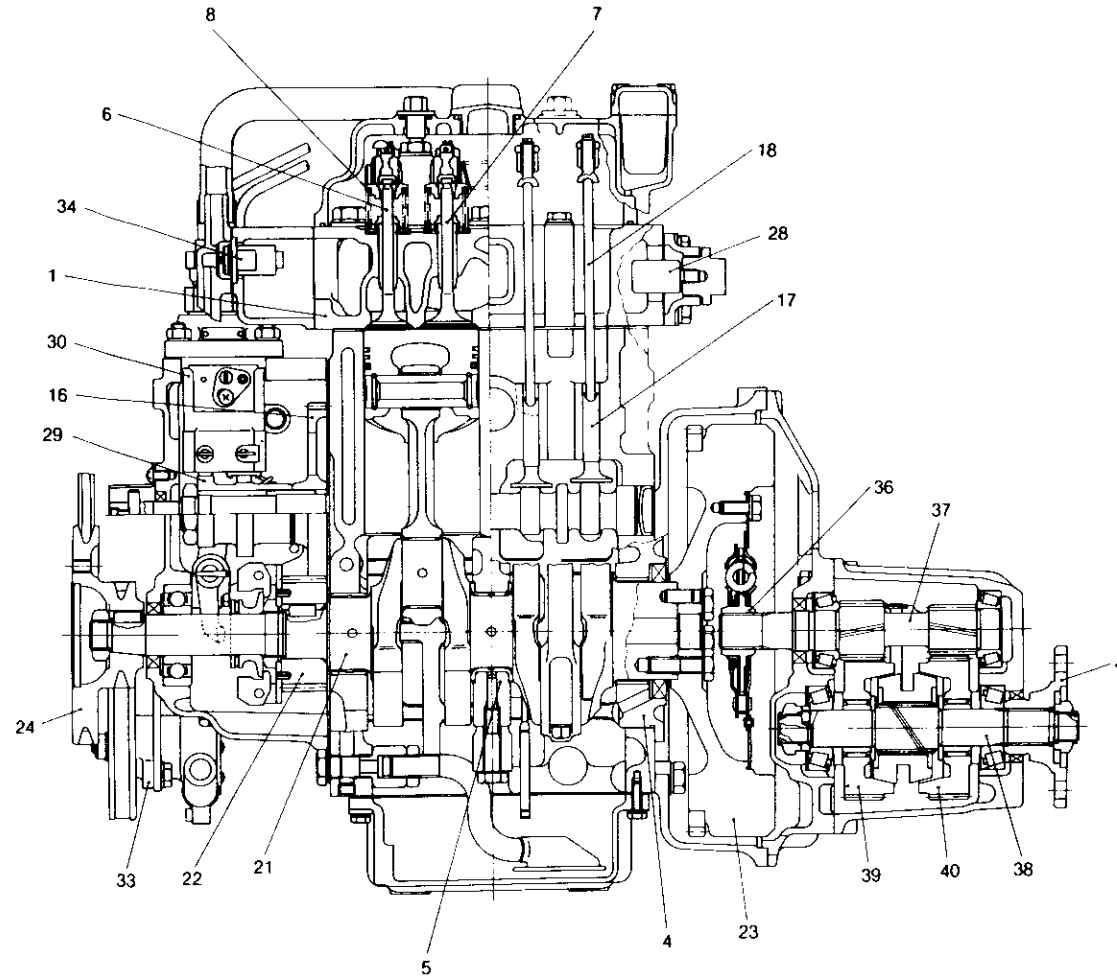
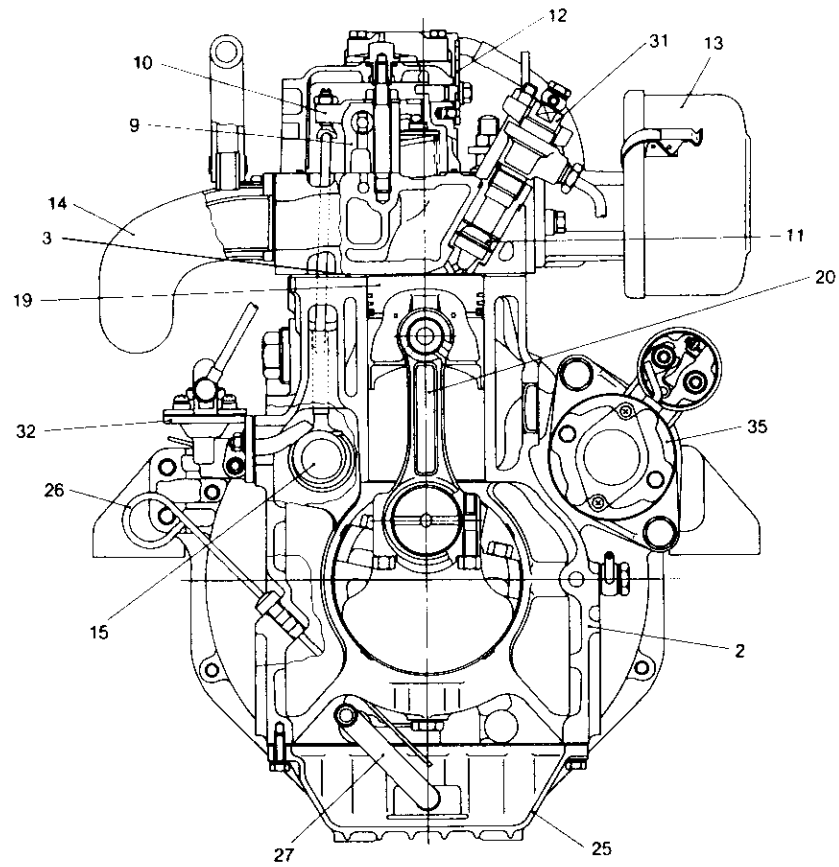

- 1. Cylinder head
- 2. Cylinder body
- 3. Cylinder head gasket
- 4. Main bearing housing
- 5. Intermediate main bearing housing
- 6. Exhaust valve
- 7. Intake valve
- 8. Valve spring
- 9. Valve rocker arm support
- 10. Valve rocker arm

- 11. Precombustion chamber
- 12. Decompression lever
- 13. Intake silencer
- 14. Exhaust manifold
- 15. Camshaft
- 16. Camshaft gear
- 17. Tappet
- 18. Push rod
- 19. Piston
- 20. Connecting rod

- 21. Crankshaft
- 22. Crankshaft gear
- 23. Flywheel
- 24. Crankshaft V-pulley
- 25. Oil pan
- 26. Dipstick
- 27. Lubricating oil inlet pipe
- 28. Anticorrosion zinc
- 29. Fuel injection pump cam
- 30. Fuel injection pump

- 31. Fuel injection nozzle
- 32. Fuel feed pump
- 33. Cooling water pump
- 34. Thermostat
- 35. Starter motor
- 36. Damper disc
- 37. Input shaft
- 38. Output shaft
- 39. Forward large gear
- 40. Reverse large gear

- 41. Output shaft coupling

5-3 3GM30

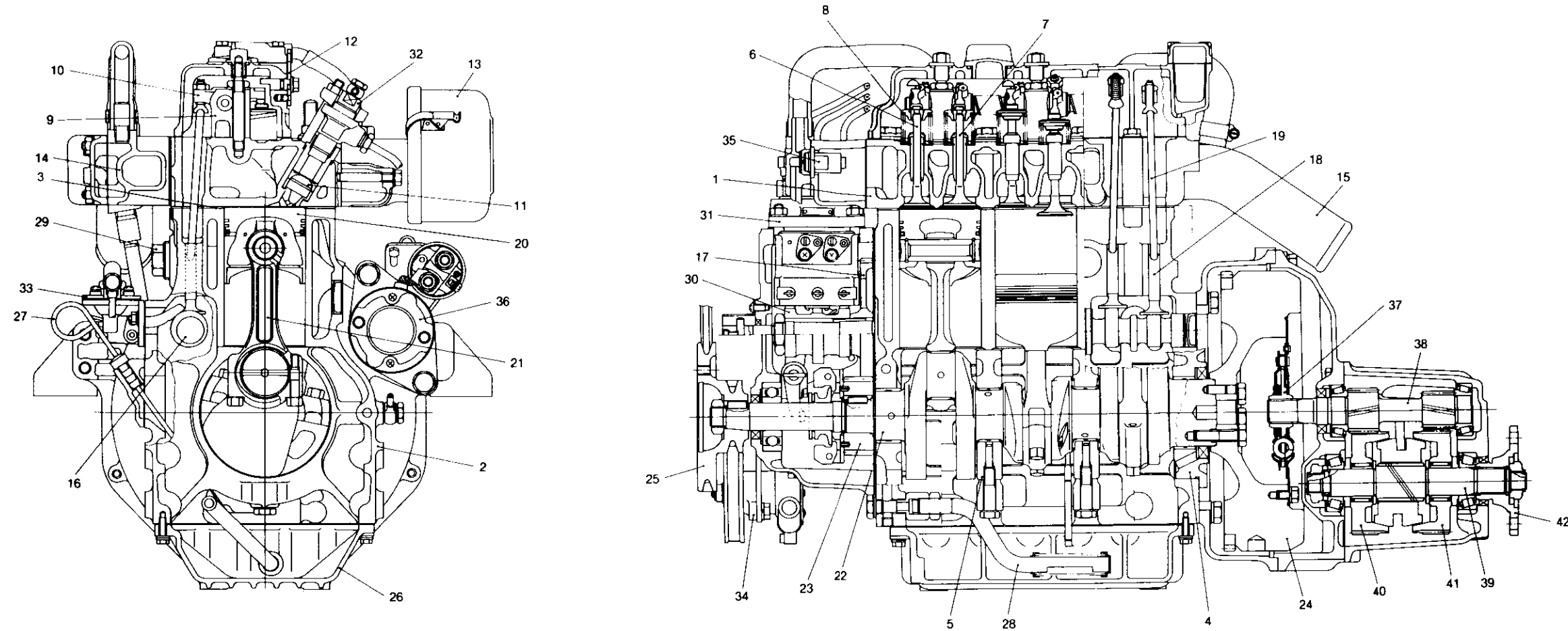

- 1. Cylinder head
- 2. Cylinder body
- 3. Cylinder head gasket
- 4. Main bearing housing
- 5. Intermediate main bearing housing
- 6. Exhaust valve
- 7. Intake valve
- 8. Valve spring
- 9. Valve rocker arm support
- 10. Valve rocker arm

- 11. Precombustion chamber
- 12. Decompression lever
- 13. Intake silencer
- 14. Exhaust manifold
- 15. Mixing elbow
- 16. Camshaft
- 17. Camshaft gear
- 18. Tappet
- 19. Push rod
- 20. Piston

- 21. Connecting rod
- 22. Crankshaft
- 23. Crankshaft gear
- 24. Flywheel
- 25. Crankshaft V-pulley
- 26. Oil pan
- 27. Dipstick
- 28. Lubricating oil inlet pipe
- 29. Anticorrosion zinc
- 30. Fuel injection pump cam

- 31. Fuel injection pump
- 32. Fuel injection nozzle
- 33. Fuel feed pump
- 34. Cooling water pump
- 35. Thermostat
- 36. Starter motor
- 37. Damper disc
- 38. Input shaft
- 39. Output shaft
- 40. Forward large gear

- 41. Reverse large gear
- 42. Output shaft coupling

5-4 3HM35

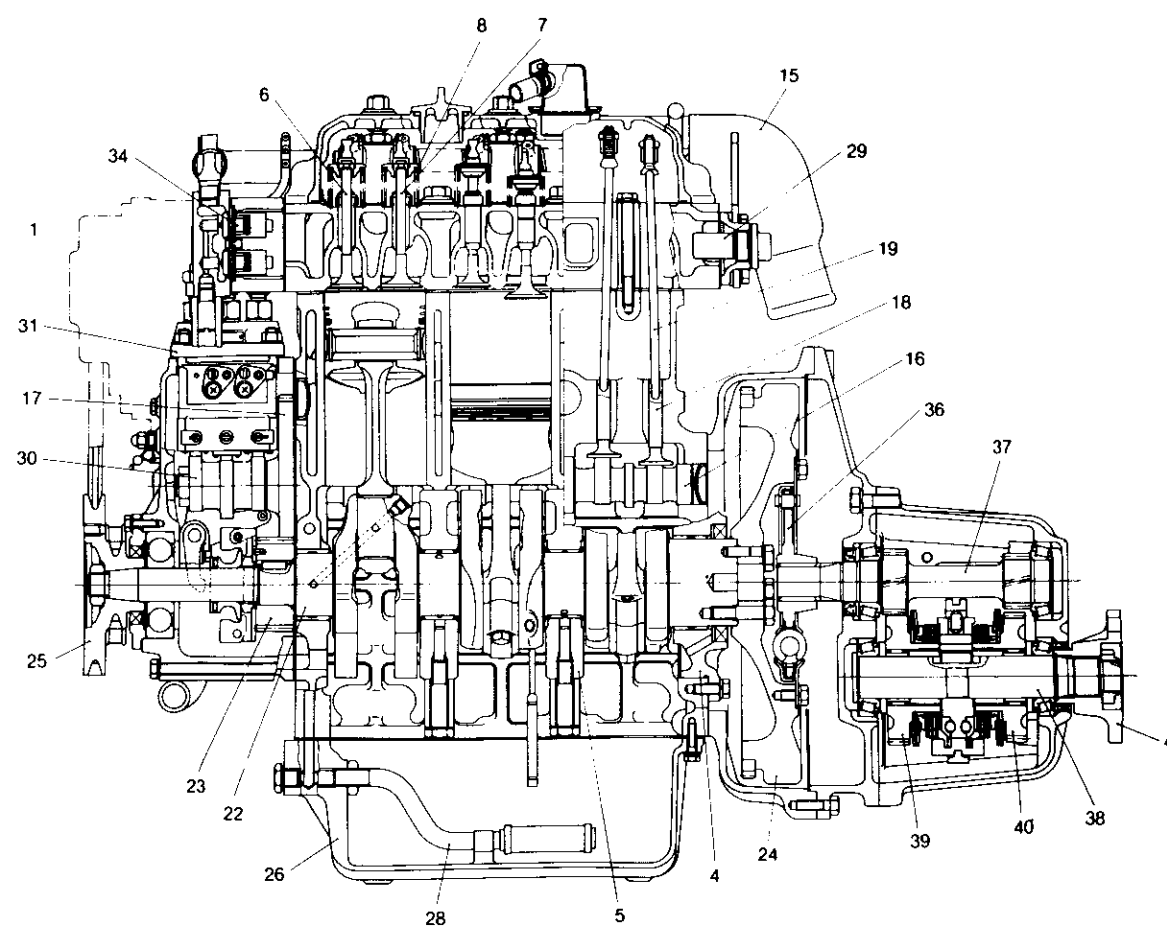
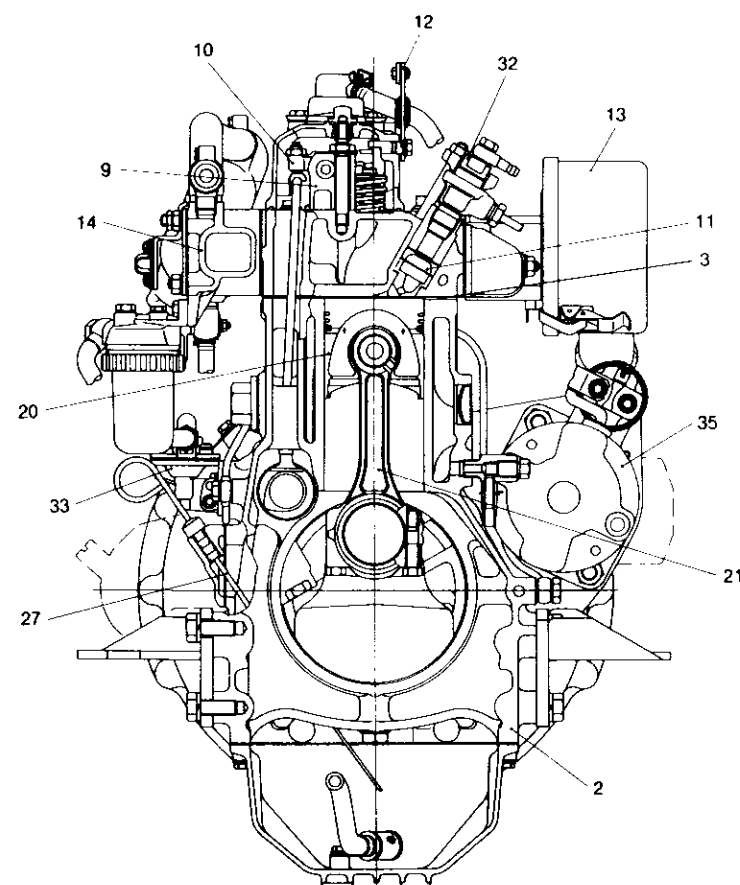

- 1. Cylinder head
- 2. Cylinder body
- 3. Cylinder head gasket
- 4. Main bearing housing
- 5. Intermediate main bearing housing
- 6. Exhaust valve
- 7. Intake valve
- 8. Valve spring
- 9. Valve rocker arm support
- 10. Valve rocker arm

- 11. Precombustion chamber
- 12. Decompression lever
- 13. Intake silencer
- 14. Exhaust manifold
- 15. Mixing elbow
- 16. Camshaft
- 17. Camshaft gear
- 18. Tappet
- 19. Push rod
- 20. Piston

- 21. Connecting rod
- 22. Crankshaft
- 23. Crankshaft gear
- 24. Flywheel
- 25. Crankshaft V-pulley
- 26. Oil pan
- 27. Dipstick
- 28. Lubricating oil inlet pipe
- 29. Anticorrosion zinc
- 30. Fuel injection pump cam

- 31. Fuel injection pump
- 32. Fuel injection nozzle
- 33. Fuel feed pump
- 34. Thermostat
- 35. Starter motor
- 36. Damper disc
- 37. Input shaft
- 38. Output shaft
- 39. Forward large gear
- 40. Reverse large gear

- 41. Output shaft coupling

5-5 2GM20F

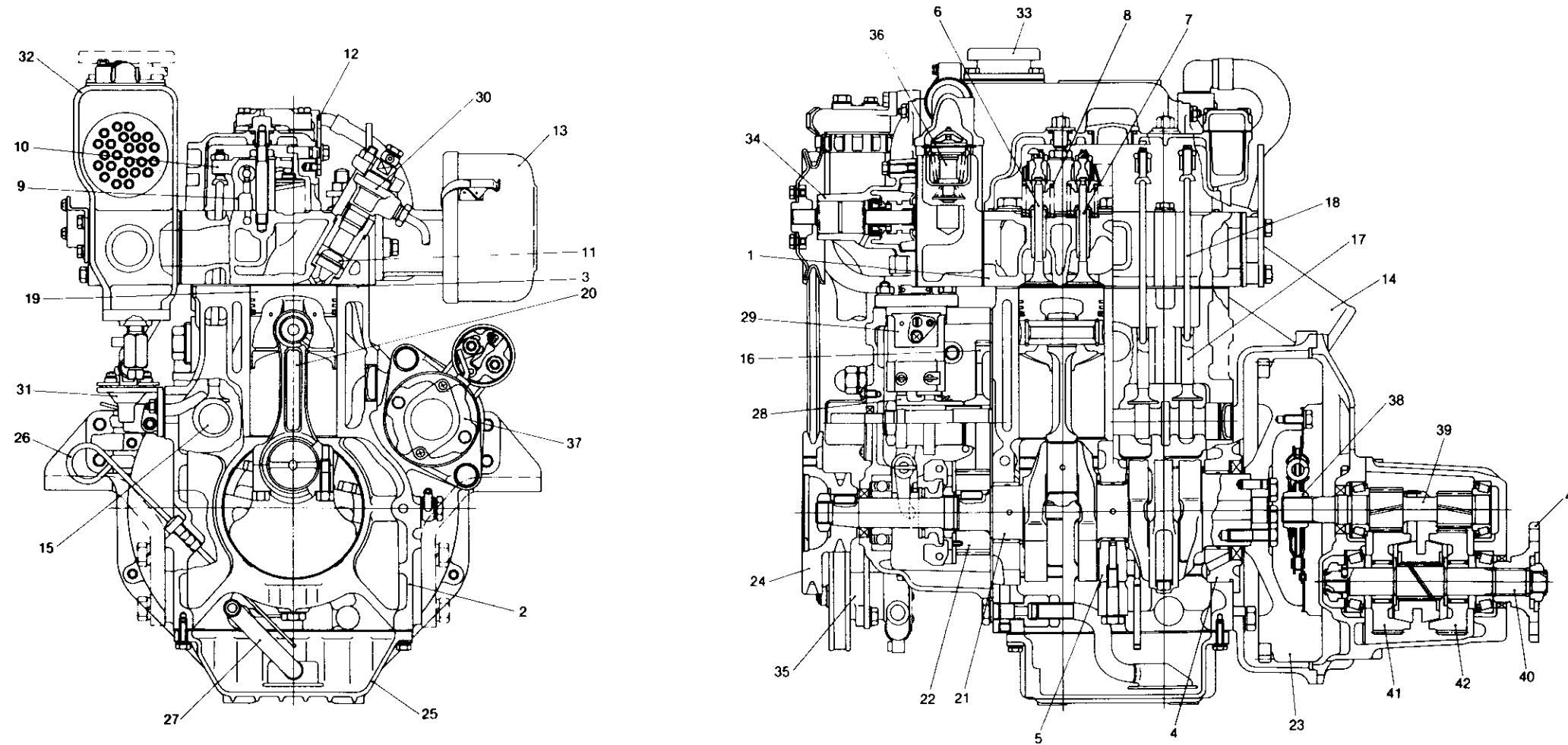

- 1. Cylinder head
- 2. Cylinder body
- 3. Cylinder head gasket
- 4. Main bearing housing
- 5. Intermediate main bearing housing
- 6. Exhaust valve
- 7. Intake valve
- 8. Valve spring
- 9. Valve rocker arm support
- 10. Valve rocker arm

- 11. Precombustion chamber
- 12. Decompression lever
- 13. Intake silencer
- 14. Mixing elbow
- 15. Camshaft
- 16. Camshaft gear
- 17. Tappet
- 18. Push rod
- 19. Piston
- 20. Connecting rod

- 21. Crankshaft
- 22. Crankshaft gear
- 23. Flywheel
- 24. Crankshaft V-pulley
- 25. Oil pan
- 26. Dipstick
- 27. Lubricating oil inlet pipe
- 28. Fuel injection pump cam
- 29. Fuel injection pump
- 30. Fuel injection nozzle

- 31. Fuel feed pump
- 32. Heat exchanger & exhaust manifold
- 33. Pressure control valve
- 34. Cooling fresh water pump
- 35. Cooling sea water pump
- 36. Thermostat
- 37. Starter motor
- 38. Damper disc
- 39. Input shaft
- 40. Output shaft

- 41. Forward large gear
- 42. Reverse large gear
- 43. Output shaft coupling

5-6 3GM30F

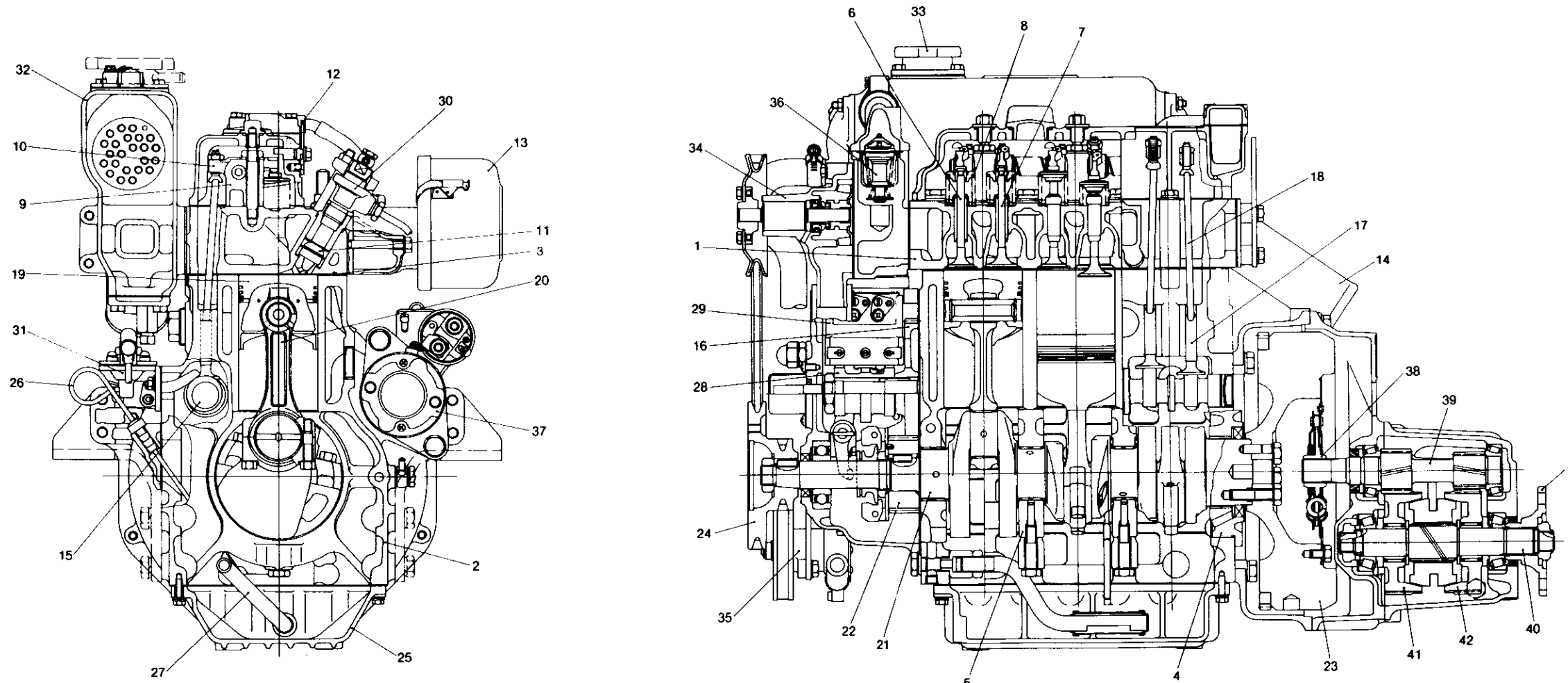

- 1. Cylinder head
- 2. Cylinder body
- 3. Cylinder head gasket
- 4. Main bearing housing
- 5. Intermediate main bearing housing
- 6. Exhaust valve
- 7. Intake valve
- 8. Valve spring
- 9. Valve rocker arm support
- 10. Valve rocker arm

- 11. Precombustion chamber
- 12. Decompression lever
- 13. Intake silencer
- 14. Mixing elbow
- 15. Camshaft
- 16. Camshaft gear
- 17. Tappet
- 18. Push rod
- 19. Piston
- 20. Connecting rod

- 21. Crankshaft
- 22. Crankshaft gear
- 23. Flywheel
- 24. Crankshaft V-pulley
- 25. Oil pan
- 26. Dipstick
- 27. Lubricating oil inlet pipe
- 28. Fuel injection pump cam
- 29. Fuel injection pump
- 30. Fuel injection nozzle

- 31. Fuel feed pump
- 32. Heat exchanger & exhaust manifold
- 33. Pressure control valve
- 34. Cooling fresh water pump
- 35. Cooling sea water pump
- 36. Thermostat
- 37. Starter motor
- 38. Damper disc
- 39. Input shaft
- 40. Output shaft

- 41. Forward large gear
- 42. Reverse large gear
- 43. Output shaft coupling

5-7 3HM35F

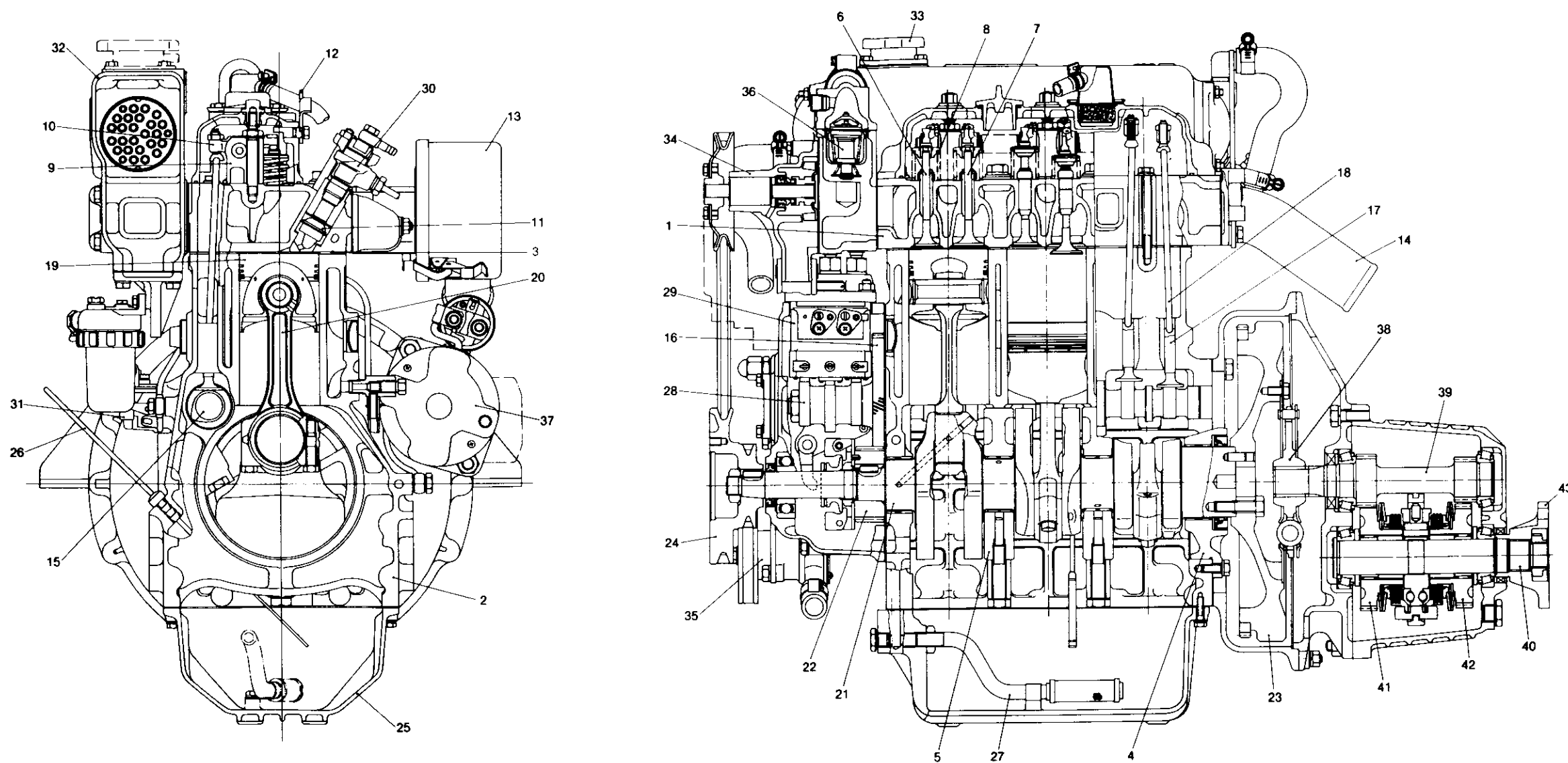

- 1. Cylinder head
- 2. Cylinder body
- 3. Cylinder head gasket
- 4. Main bearing housing
- 5. Intermediate main bearing housing
- 6. Exhaust valve
- 7. Intake valve
- 8. Valve spring
- 9. Valve rocker arm support
- 10. Valve rocker arm

- 11. Precombustion chamber
- 12. Decompression lever
- 13. Intake silencer
- 14. Mixing elbow
- 15. Camshaft
- 16. Camshaft gear
- 17. Tappet
- 18. Push rod
- 19. Piston
- 20. Connecting rod

- 21. Crankshaft
- 22. Crankshaft gear
- 23. Flywheel
- 24. Crankshaft V-pulley
- 25. Oil pan
- 26. Dipstick
- 27. Lubricating oil inlet pipe
- 28. Fuel injection pump cam
- 29. Fuel injection pump
- 30. Fuel injection nozzle

- 31. Fuel feed pump
- 32. Heat exchanger & exhaust manifold
- 33. Pressure control valve
- 34. Cooling fresh water pump
- 35. Cooling sea water pump
- 36. Thermostat
- 37. Starter motor
- 38. Damper disc
- 39. Input shaft
- 40. Output shaft

- 41. Forward large gear
- 42. Reverse large gear
- 43. Output shaft coupling

6. Dimensions

6-1 1GM10

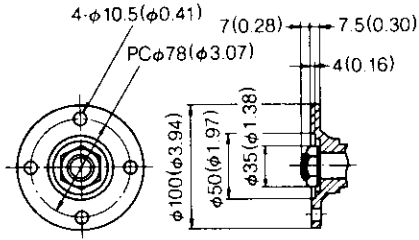

Detail of coupling (A)

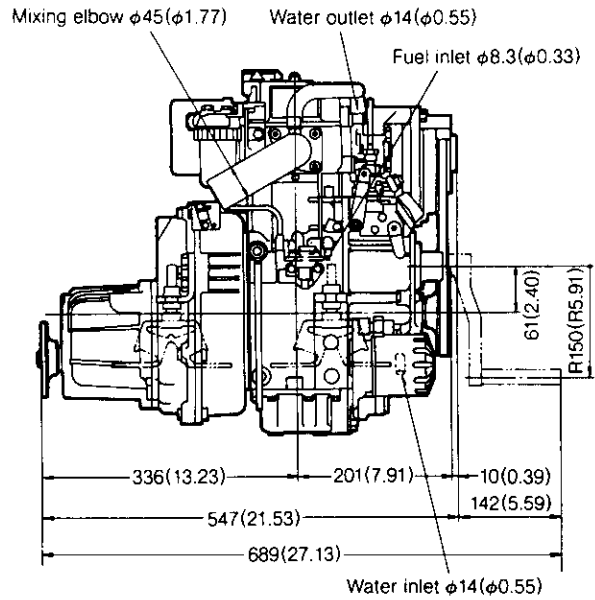
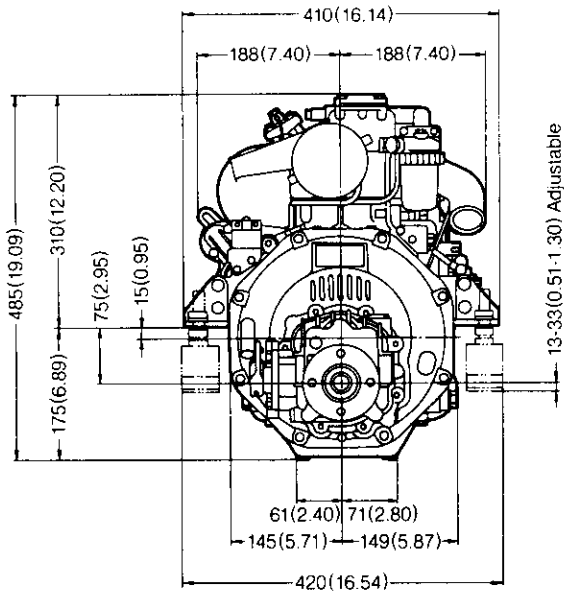
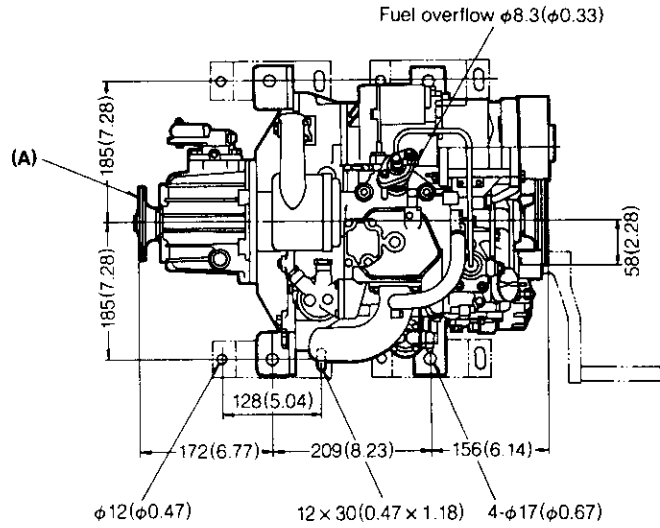

6-2 2GM20

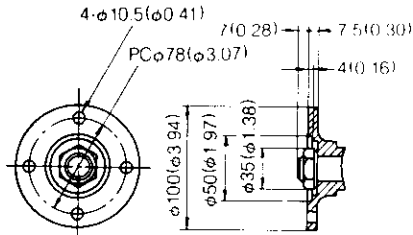

Detail of coupling (A)

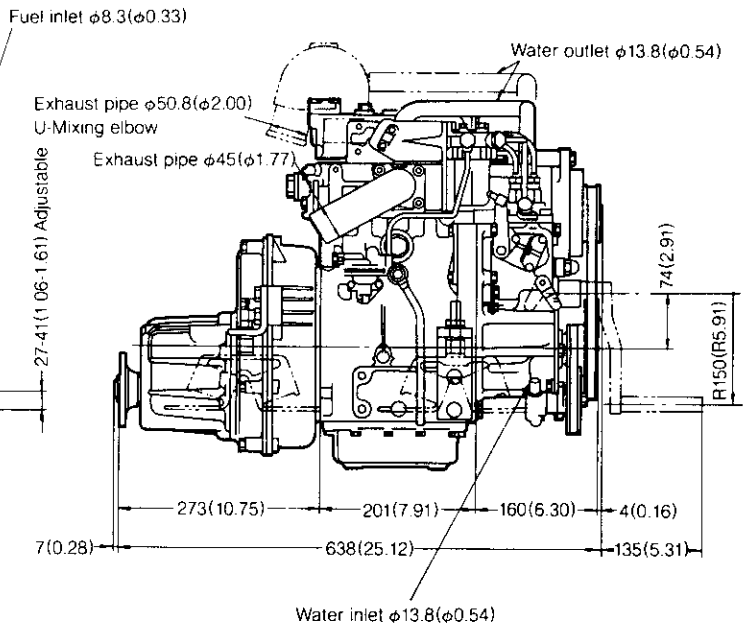
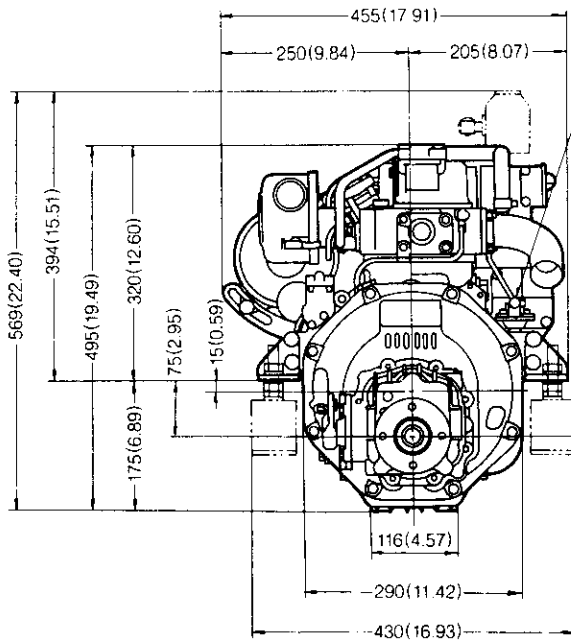
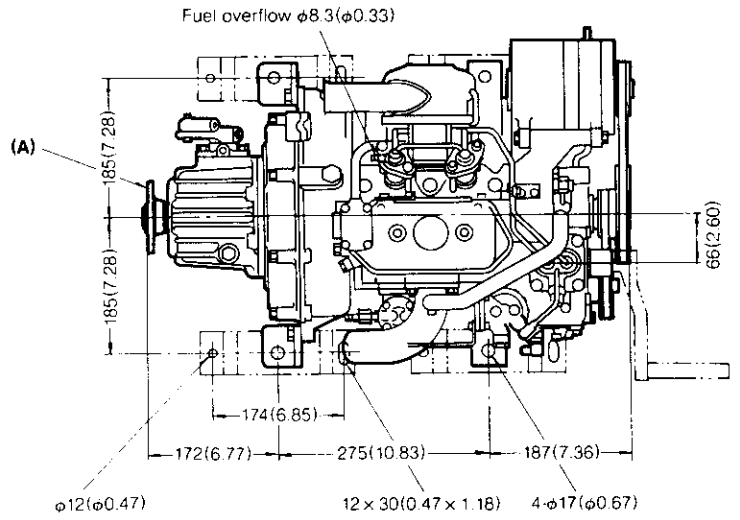

6-3 3GM30

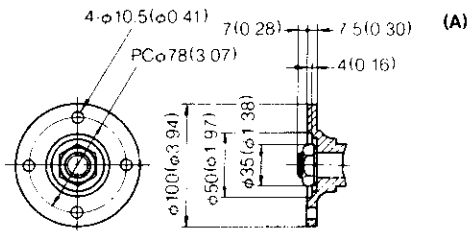

Detail of coupling (A)

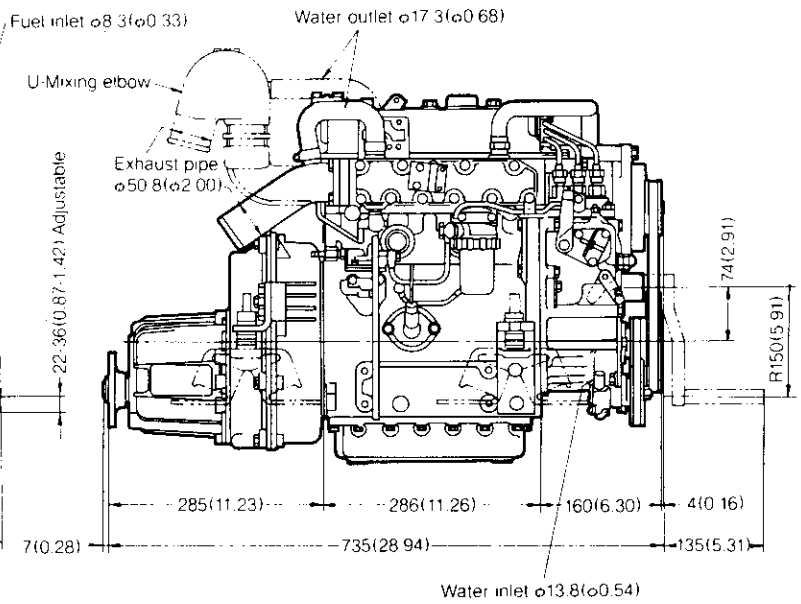
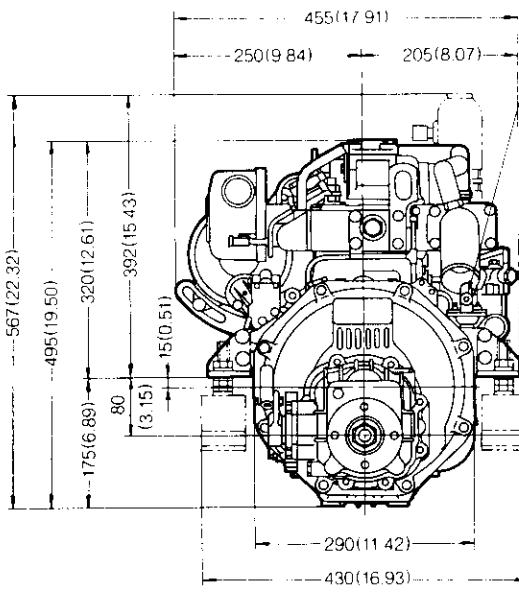
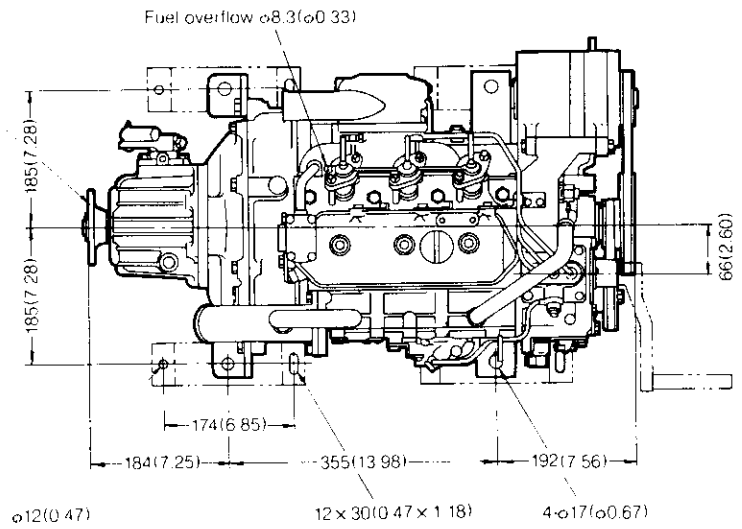

6-4 3HM35

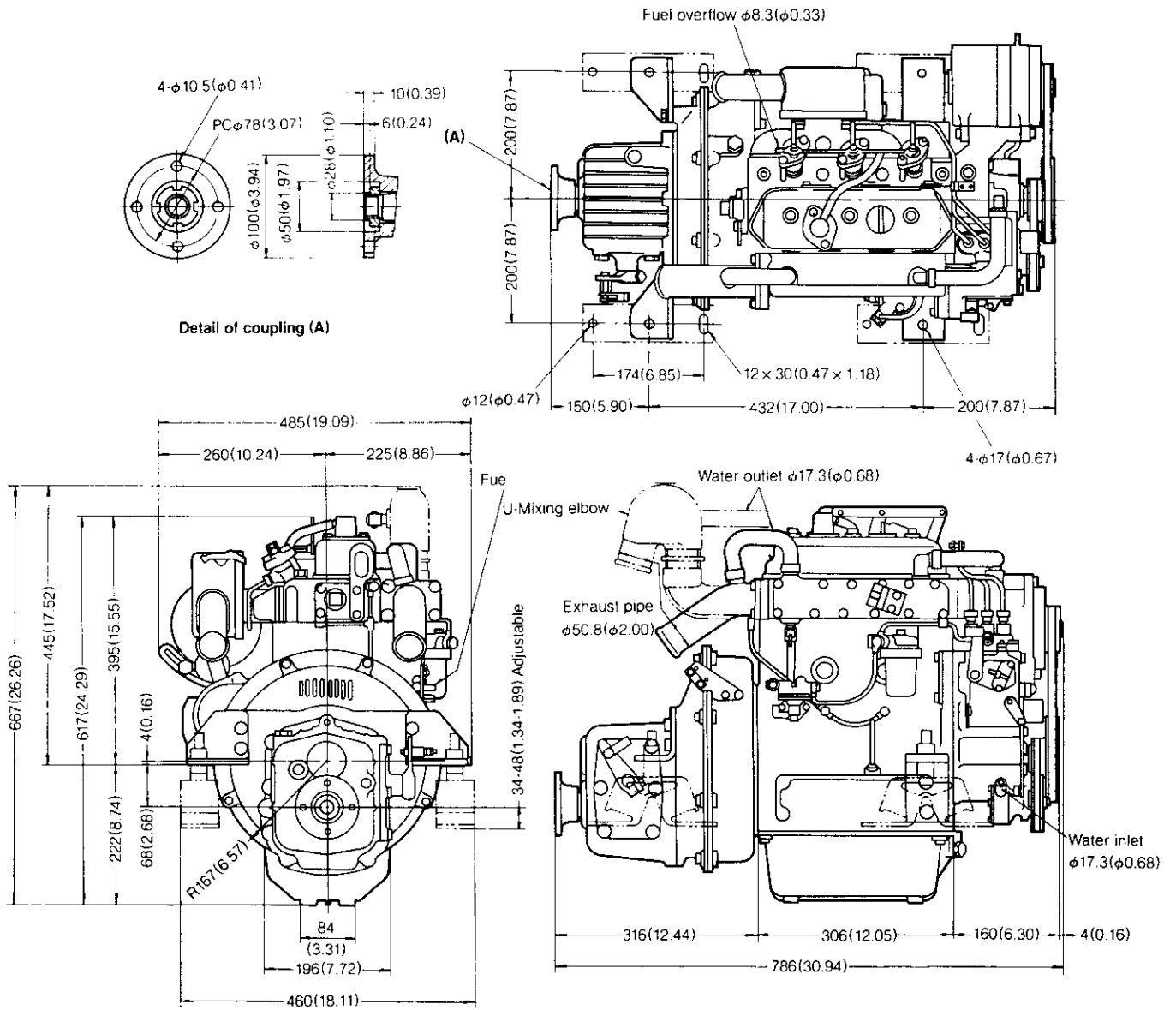

6-5 2GM20F

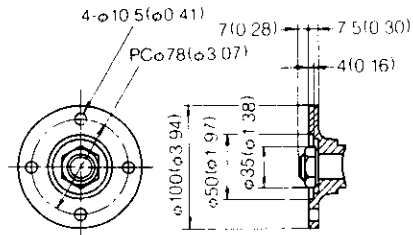

Detail of coupling (A)

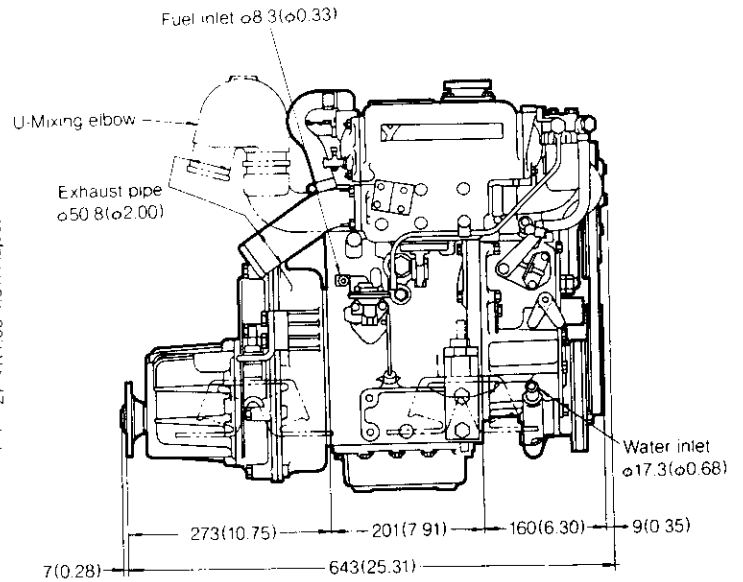
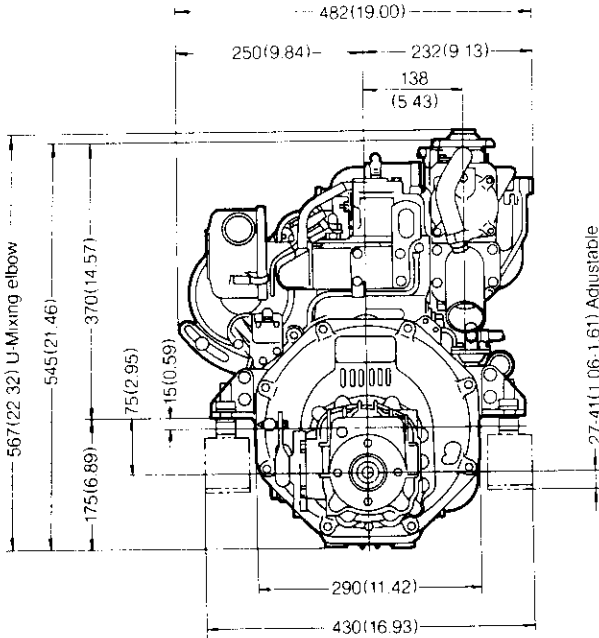
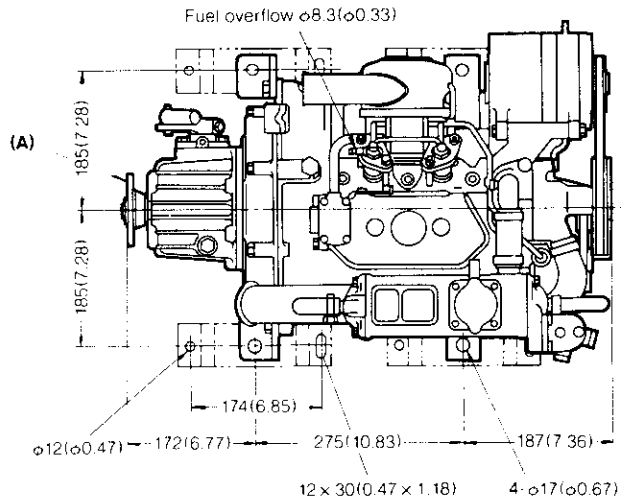

6-6 3GM30F

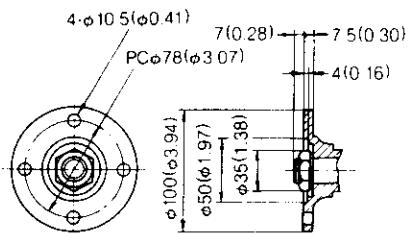

Detail of coupling (A)

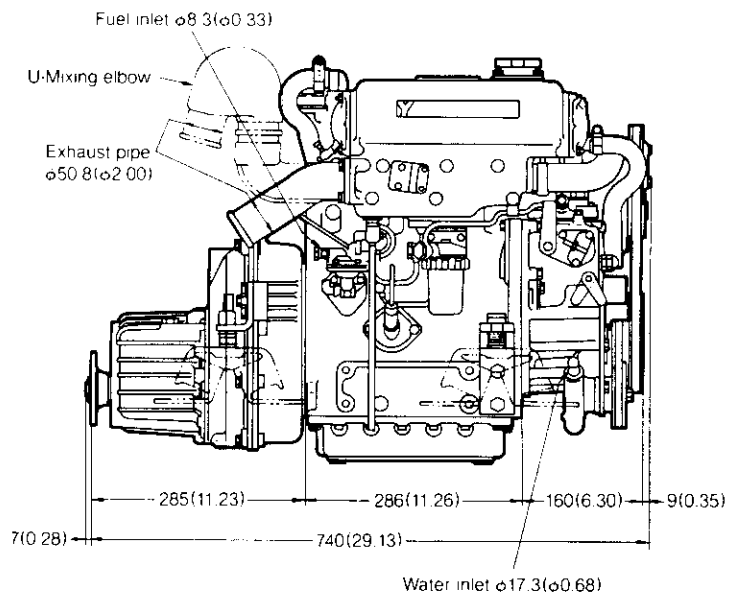
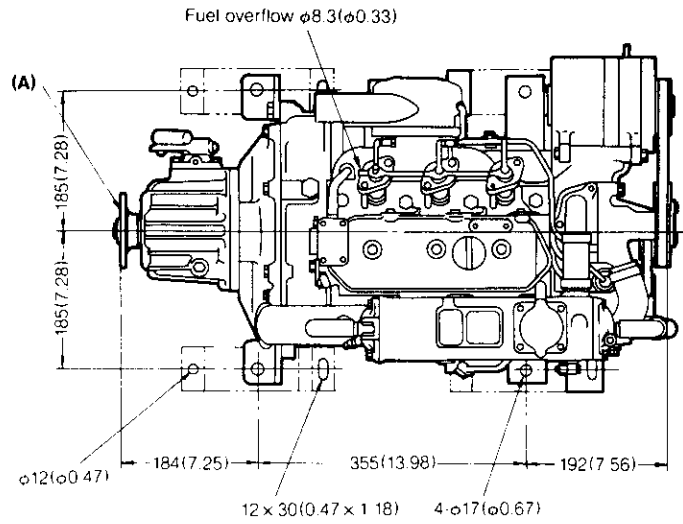
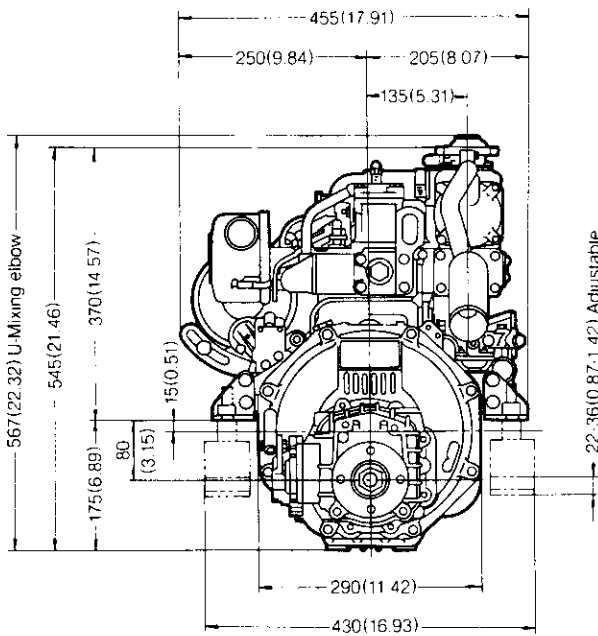

6-7 3HM35F

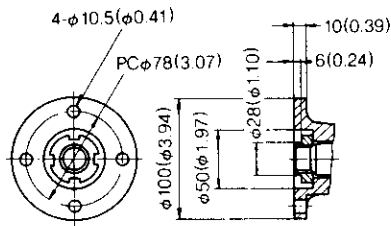

Detail of coupling (A)

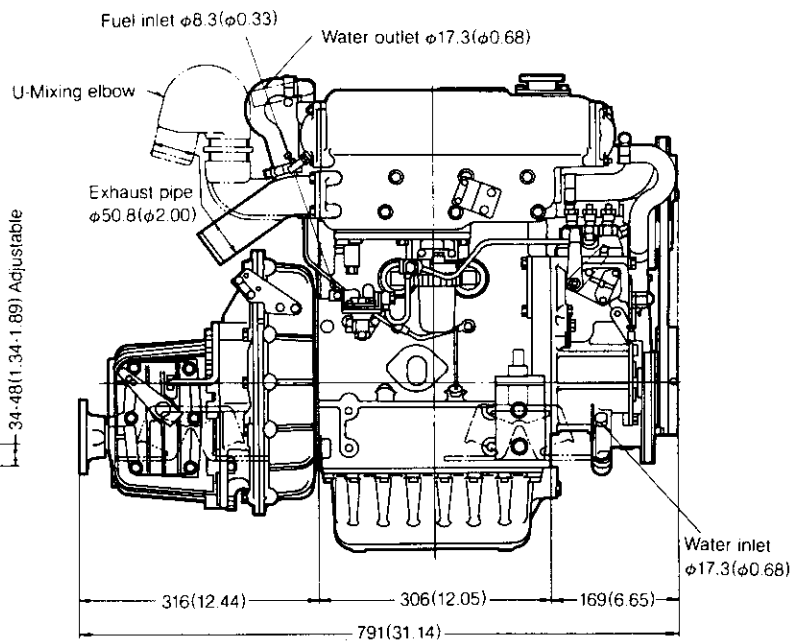
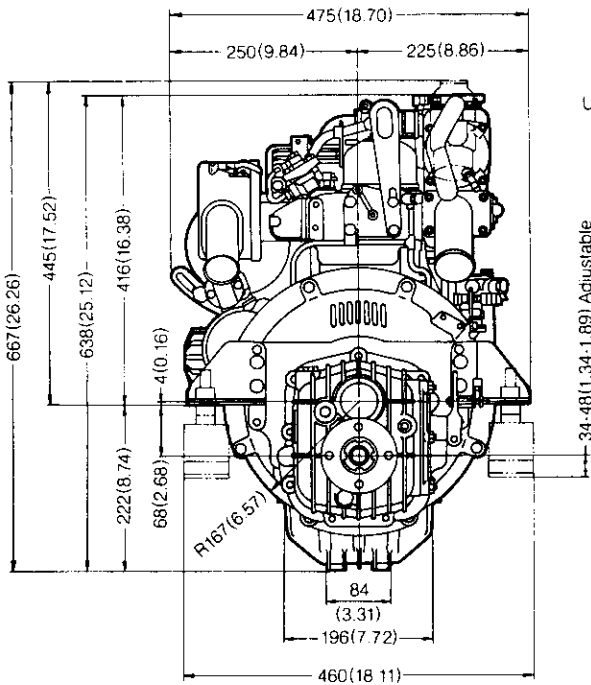
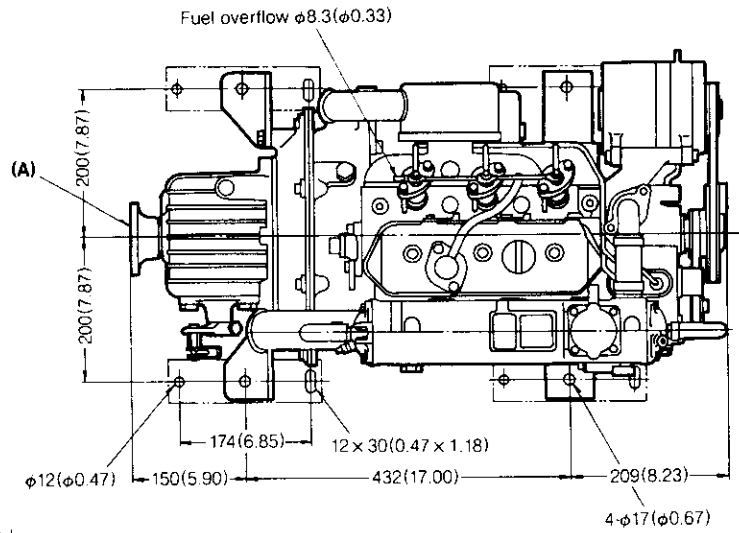

CHAPTER 2

BASIC ENGINE

1. Cylinder Block	2-1
2. Cylinder Head	2-9
3. Piston	2-28
4. Connecting Rod	2-34
5. Crankshaft	2-38
6. Flywheel and Housing	2-49
7. Camshaft	2-53
8. Timing Gear	2-59

1. Cylinder Block

1-1 Construction

The cylinder block comprises a single unit casting for the cylinder body without the use of cylinder liners.

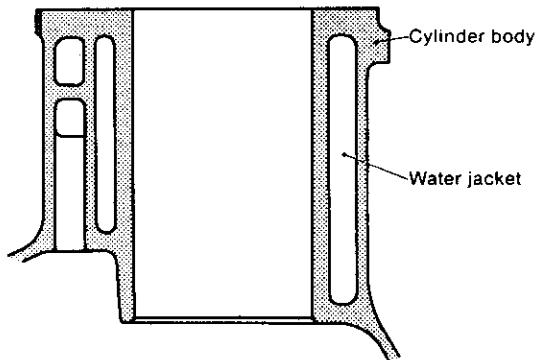

The cylinder block is a high-quality cast iron casting, with integral cylinders and deep skirt crankcase construction. As a result of stress analyses, the shape and thickness of each part has been optimized, and special ribs employed which not only increase the strength and rigidity of the block, but also reduce noise.

1-1.1 Cylinder of model 1GM10(C) engine

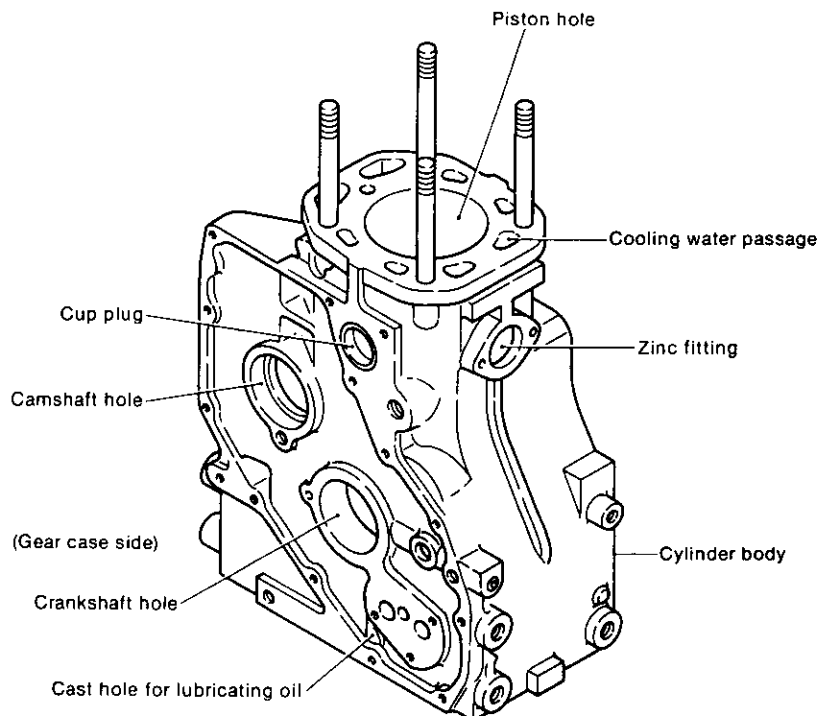

1-1.2 Cylinder of model 2GM20(F)(C) engine

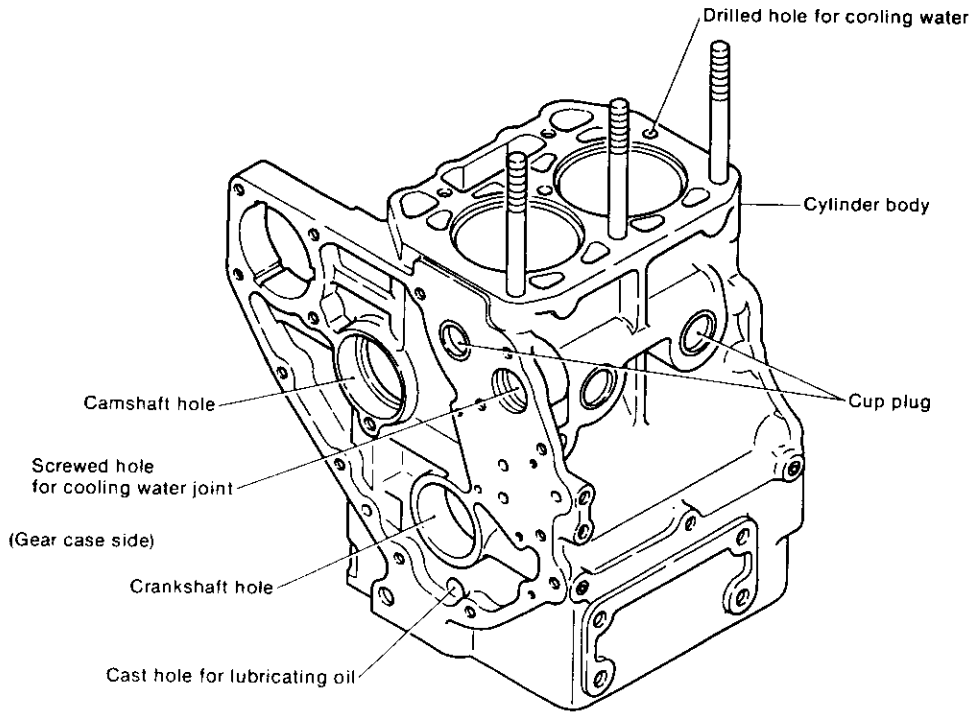

1-1.3 Cylinder of model 3GM30(F)(C) engine

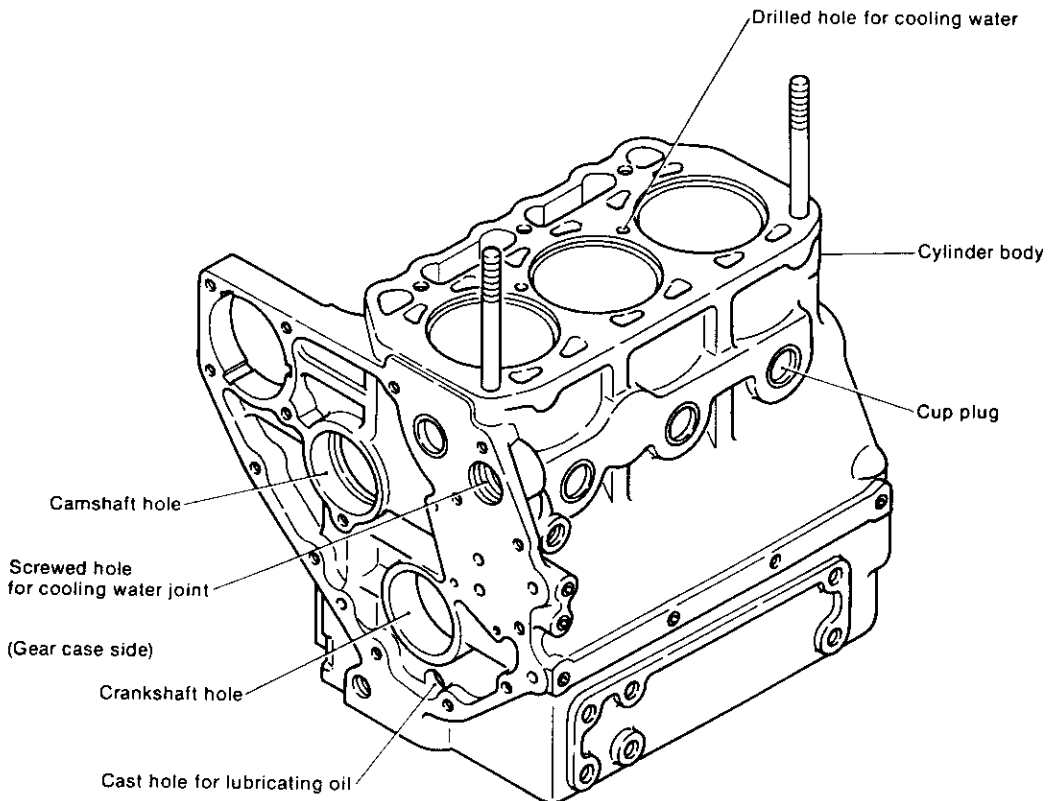

1-1.4 Cylinder of model 3HM35(F)(C) engine

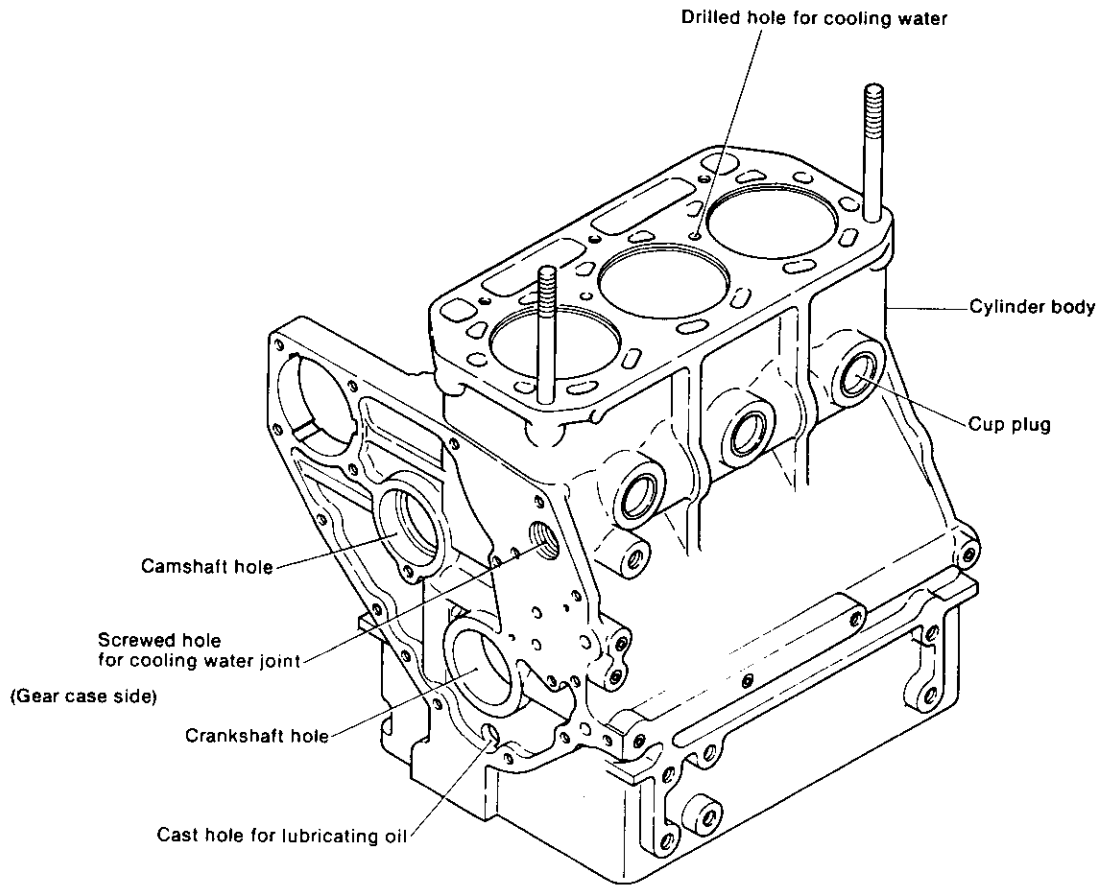

1-2 Cylinder block inspection

1-2.1 Inspecting each part for cracks

If the engine has been frozen or dropped, visually inspect it for cracks and other abnormalities before disassembling. If there are any abnormalities or the danger of any abnormalities occurring, make a color check.

1-2.2 Inspecting the water jacket of the cylinder for corrosion

Inspect the cooling water passages for sea water corrosion, scale, and rust. Replace the cylinder body if corrosion, scale or rust is severe.

1-2.3 Cylinder head stud bolts

Check for loose cylinder head bolts and for cracking caused by abnormal tightening, either by visual inspection or by a color check.

Replace the cylinder block if cracked.

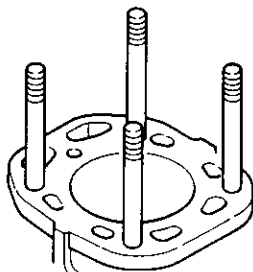

1GM10(C)

Bolt diameter	M10
Pitch	1.5
Tightening torque	6.0kgf-m(43.4 ft-lb)

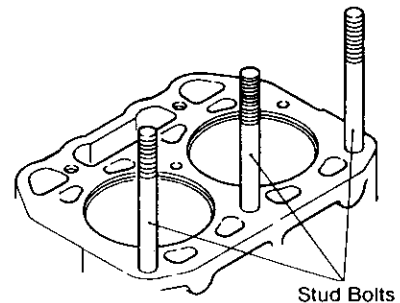

2GM20(F)(C)

Bolt diameter	M12
Pitch	1.25
Tightening torque	8.0kgf-m(57.9 ft-lb)

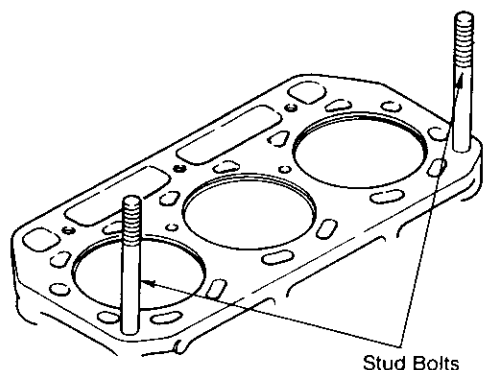

	3GM30(F)(C)	3HM35(F)(C)	kgf-m(ft-lb)
Bolt diameter	M12		
Pitch	1.25		
Tightening torque	8.0(57.9)	10.0(72.3)	

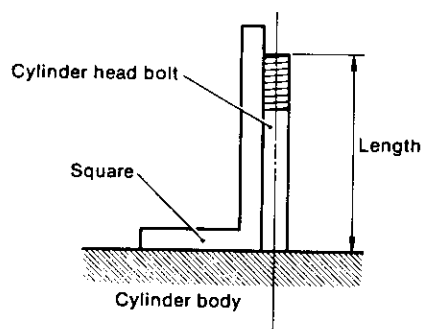
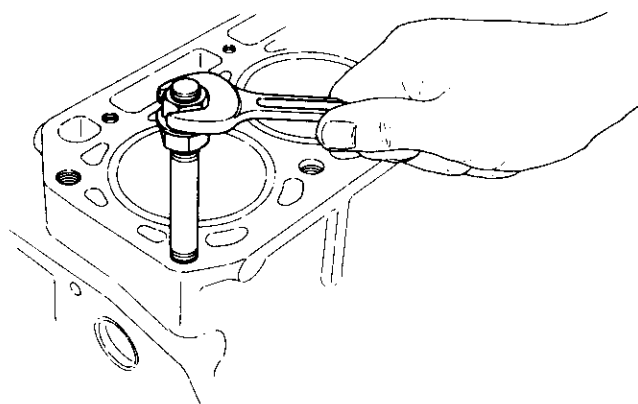

1-2.4 Oil and water passages

Check the oil and water passages for clogging and build-up of foreign matter.

1-2.5 Color check flaw detection procedure

- (1) Clean the inspection point thoroughly.
- (2) Procure the dye penetration flaw detection agent. This agent comes in spray cans, and consists of a cleaner, penetrant, and developer in one set.

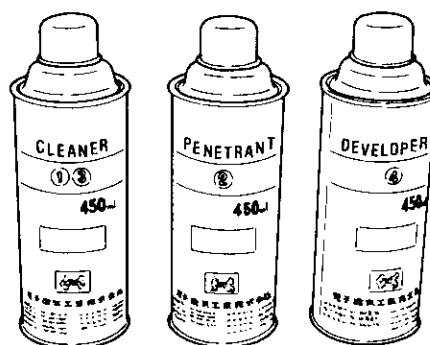

- (3) Pretreat the inspection surface with the cleaner. Spray the cleaner directly onto the inspection surface, or wipe the inspection surface with a cloth moistened with the cleaner.
- (4) Spray the red penetration liquid onto the inspection surface. After cleaning the inspection surface, spray the red penetrant (dye penetration flaw detection agent) onto it and allow the liquid to penetrate for 5-10 minutes. If the penetrant fails to penetrate the inspection surface on account of the ambient temperature or for other reasons, allow it to dry and respray the inspection surface.
- (5) Spray the developer onto the inspection surface. After penetration processing, remove the residual penetrant from the inspection surface with the cleaner, and then spray the developer onto the inspection surface. If the inspection surface is flawed, red dots or lines will appear on the surface within several minutes. When spraying the developer onto the inspection surface, hold the can about 30—40cm from the surface and sweep the can slowly back and forth to obtain a uniform film.
- (6) Reclean the inspection surface with the cleaner.

NOTE: Before using the dye penetration flaw detection agent, read its usage instructions thoroughly.

1-3 Cylinder bore measurement

Cylinder wear is measured with a cylinder gauge. The amount of cylinder wear becomes greater as the piston nears the top, and it becomes greatest at the position of the top ring when the piston is in top dead center. The reason for this is that when the piston is at the top position, lateral pressure is high due to the high explosive pressure, and lubrication is very difficult due to the high temperature. Therefore, the amount of wear must be measured in at least 3 positions, namely the top, middle and bottom positions of the cylinder.



Suggest:

For more complete manuals. Please go to the home page.

<https://www.ebooklibonline.com>

If the above button click is invalid. Please download this document first, and then click the above link to download the complete manual.

Thank you so much for reading

Although the greatest wear is at the top of the cylinder, the piston ring does not slide with the cylinder at the topmost position. Therefore, a step-like pattern is formed between the worn part and the non-worn part.

Furthermore, wear is liable to occur along the rotating direction of the crankshaft due to the lateral pressure of the piston. On the other hand, wear occurs in the direction of

the crankshaft center line due to the thrust of the crankshaft and the angle of the connecting rod.

Therefore, the amount of wear must be measured in the directions of crankshaft rotation and the crankshaft center line. When the difference of these two values (i.e. circularity wear) is large, the cylinder must be repaired.

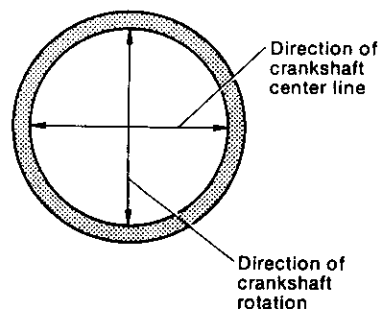
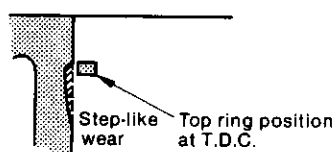
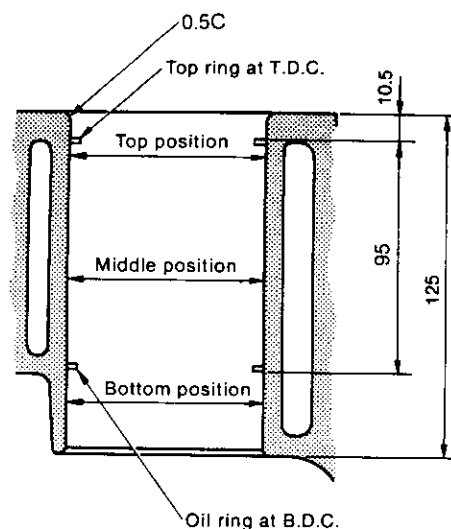
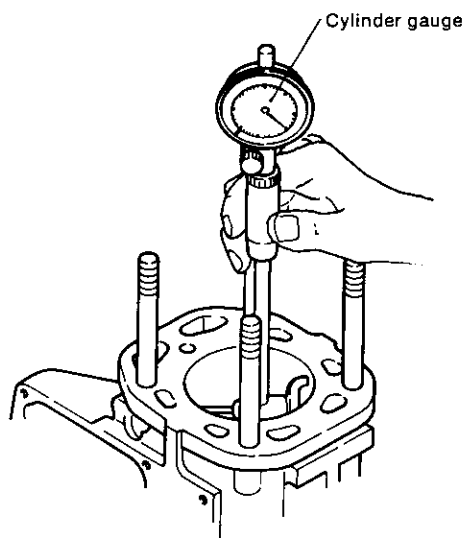

	1GM10(C),2GM20(F)(C),3GM30(F)(C)		3HM35(F)(C)	
	Maintenance standard	Wear limit	Maintenance standard	Wear limit
Cylinder diameter	$\phi 75.0 \sim 75.03$ (2.9528~2.9540)	$\phi 75.10$ (2.9567)	$\phi 80.0 \sim 80.03$ (3.1496~3.1508)	$\phi 80.10$ (3.1535)
Cylinder roundness	0~0.01 (0~0.0004)	0.02 (0.0008)	0~0.01 (0~0.0004)	0.02 (0.0008)

When the result indicates that eccentric and circularity wear exceed the specified limit, the cylinder must be rebored.

1-3.2 Boring the cylinder

When wear on the inside of the cylinder is excessive, rectify by machining. This is what is known as boring.

When boring is carried out, note the following points.

(1) Dimension to be bored

The cylinder must be bored to the same dimension as an over-size piston.

Over-size piston	mm(in.)	
ENG. MODEL	O.D. of standard piston	O.D. of over-size piston
1GM10(C) 2GM20(F)(C) 3GM30(F)(C)	φ75 (2.9528)	φ75.25 (2.9626)
3HM35(F)(C)	φ80 (3.1496)	φ80.25 (3.1594)

(2) Limit of cylinder's expanded I.D.

Never bore the cylinder beyond the limit of the expanded inner diameter, because no over-size piston is available for that dimension, besides which there is danger in having too thin a wall thickness.

Limit of cylinder's expanded I.D.	mm(in.)	
ENG. MODEL	I.D. of standard cylinder	Limit of I.D. expansion
1GM10(C) 2GM20(F)(C) 3GM30(F)(C)	φ75.0~75.03 (2.9528~2.9540)	φ75.25~75.28 (2.9626~2.9638)
3HM35(F)(C)	φ80.0~80.03 (3.1496~3.1508)	φ80.25~80.28 (3.1595~3.1606)

Locator points of cylinder block

For the re-boring of the piston bore in the cylinder block, use the following locator positions. Before re-boring, be sure to remove packings and dust from the locator points.

- 1GM10(C)
Main locator: Oil pan side
Sub locator: Timing gear case and F.O. feed pump side
- 2GM20(F)(C), 3GM30(F)(C), 3HM35(F)(C)
Oil pan side and φ2-pin holes

(3) Boring procedures

- 1GM10(C)
For processing the bore, face the oil pan side to the bottom and place the fixing faces of the gear case and the feed pump.

(2) 2GM20(F)(C), 3GM30(F)(C)

For processing bring the oil pan side to the bottom, and insert a pin to the 2-φ12^{+0.018}₀ (15mm depth) locator hole.

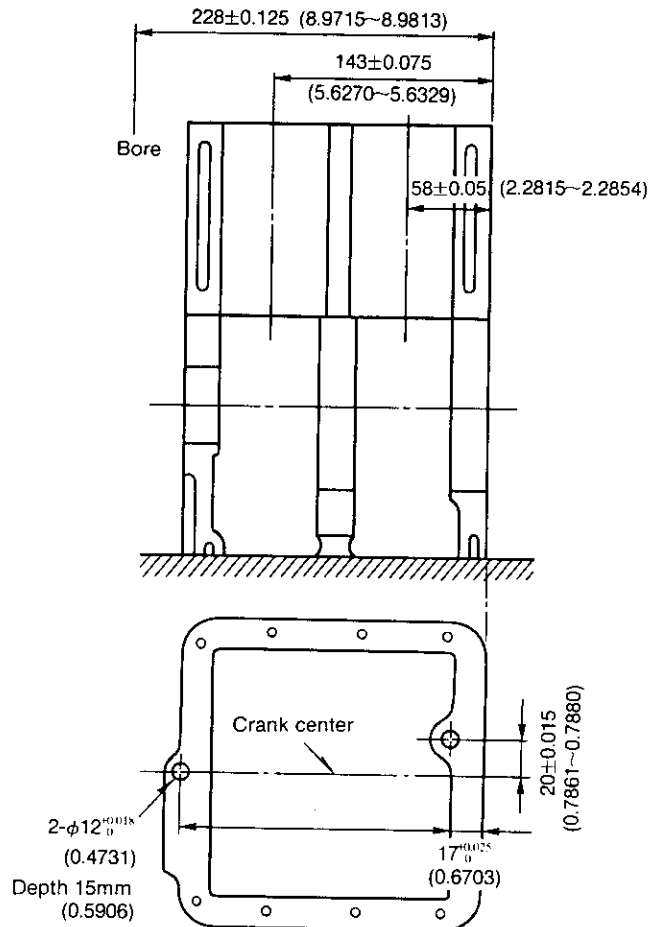

"I" dimension
2GM20: 172±0.05 (6.7697~6.7736)
3GM30: 257±0.05 (10.1161~10.1201)

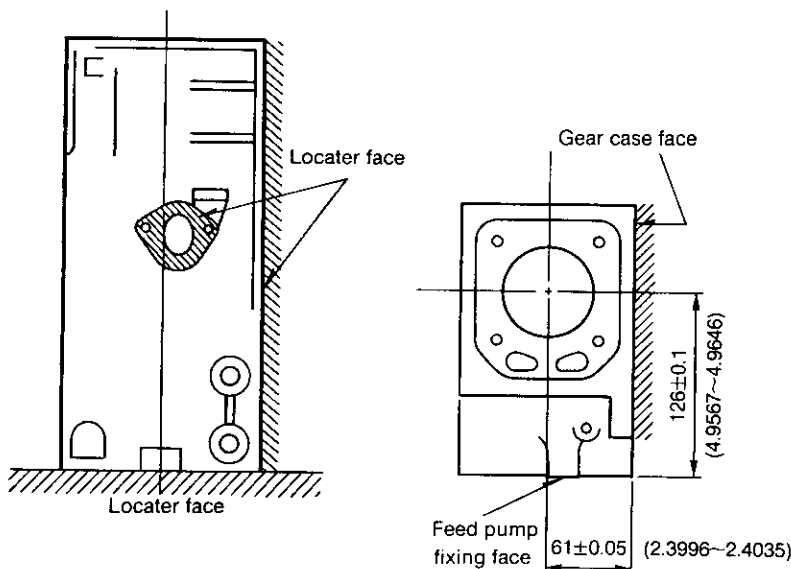

(3) 3HM35

For processing bring the oil pan side to the bottom, and insert a pin to the $2-\phi 12^{+0.018}_0$ (15mm depth) locator hole.

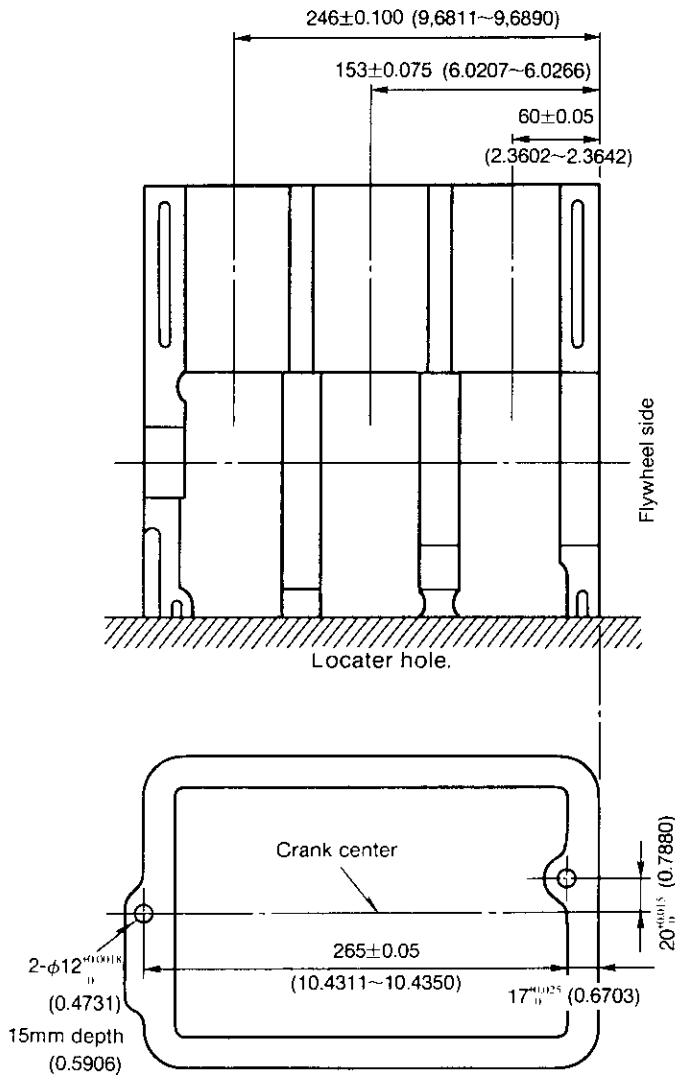

(1) How to measure distortion on the upper surface of the cylinder

The amount of distortion is measured by placing a straight scale on the upper surface of the cylinder and inserting a thickness gauge between the upper surface of the cylinder and the straight scale.

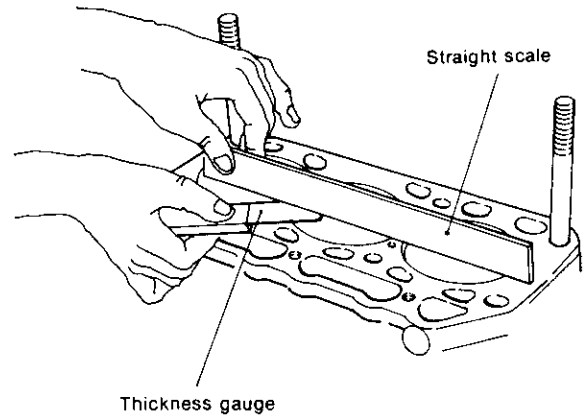

Measurement is to be carried out on the 4 sides and 2 diagonal lines as shown in the figure, and the largest value of clearance for each measurement is to be taken as the amount of distortion.

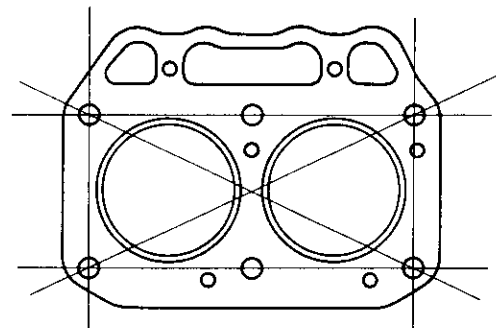

mm (in.)

(4) Honing

The inside surface of the cylinder must be honed after being bored in order to remove machine tool marks.

1-4 Measurement of distortion on the upper surface of the cylinder

As the cylinder is repeatedly subjected to thermal expansion and high pressure it will not recover its original shape after the engine has stopped and cooled down and will be distorted. The distortion is mainly caused by construction and material differences of the cylinder, but may arise from the cylinder head bolts being tightened in the wrong order or an uneven tightening torque of the bolts when assembling. If there is any distortion at the upper surface of the cylinder, it will cause a compression pressure leakage, gas leakage or water leakage as a clearance is formed around the cylinder head even though the cylinder head is thoroughly secured.

	Allowable limit of distortion
1GM10(C)	0.05(0.002)
2GM20(F)(C)	0.05(0.002)
3GM30(F)(C) 3HM35(F)(C)	0.05(0.002)

<https://www.ebooklibonline.com>

Hello dear friend!

Thank you very much for reading.

Enter the link into your browser.

The full manual is available for immediate download.

<https://www.ebooklibonline.com>