

ERC35HG, ERC40HG, ERC45HG, ERC55HG (ERC070-120HH) (B839)

SERVICE MANUAL CONTENTS

SECTION	PART NUMBER	YRM NUMBER	REV DATE
FRAME.....	524238572	0100 YRM 1200	11/06
AC MOTOR REPAIR.....	524205680	0620 YRM 1098	03/10
DRIVE AXLE, SPEED REDUCER, AND DIFFERENTIAL.....	524166834	1400 YRM 0413	11/06
STEERING AXLE.....	524150783	1600 YRM 0326	03/07
STEERING CONTROL UNIT.....	524158753	1600 YRM 0720	11/06
STEERING SYSTEM.....	524183081	1600 YRM 1054	11/06
BRAKE SYSTEM.....	524166837	1800 YRM 0338	05/09
HYDRAULIC SYSTEM.....	524179945	1900 YRM 0559	04/09
MAIN CONTROL VALVE.....	524166839	2000 YRM 0077	02/09
TILT CYLINDERS.....	524150790	2100 YRM 0103	03/07
ELECTRICAL SYSTEM.....	524183082	2200 YRM 1055	10/09
AC MOTOR CONTROLLER DESC/CHKS/ADJ/TRBSHT/REP&THEORY OF OPERATION/DISPLAY PANEL.....	524183083	2200 YRM 1056	03/09
TROUBLESHOOTING AND ADJUSTMENTS USING THE AC CONTROLS PROGRAM.....	524183085	2200 YRM 1058	04/11
INDUSTRIAL BATTERY.....	524158040	2240 YRM 0001	09/14
MASTS.....	524153920	4000 YRM 0736	07/10
LIFT CYLINDER.....	524153919	4000 YRM 0741	03/05
METRIC AND INCH (SAE) FASTENERS.....	524150797	8000 YRM 0231	10/13
PERIODIC MAINTENANCE.....	524238574	8000 YRM 1201	02/10
CAPACITIES AND SPECIFICAITONS.....	524238575	8000 YRM 1202	11/06
DIAGRAMS.....	524238576	8000 YRM 1203	02/09

PART NO. 524238569 (09/14)

General

This section has a description and the service procedures for the parts of the frame. These parts include the frame, counterweight assembly, overhead guard, hood and seat assembly, access panels, and label positions. The procedure for removing the traction motor is also described in this section.

Description

The frame is a single weldment. See Figure 1. The frame has mounts for the following:

- Counterweight
- Overhead guard
- Tilt cylinders
- Steering axle
- Drive axle assembly

The hydraulic tank is part of the lift truck frame and is a welded steel unit. The lift trucks must have a hood over the battery, or a covered battery if a hood is not installed. The floor plates can be removed for access to the hydraulic systems. A panel in the bottom of the battery compartment can be removed for access to the traction motor and the hydraulic pump motor. The power steering pump and motor and master controller is located under the floor plate on the left side of the lift truck. The E-hydraulic control valve driver module is located under the floor plate next to the hydraulic filter. The AC electronic controllers and contactors are in the counterweight. A panel in the counterweight can be removed for access to the AC controllers and contactors.

The lift truck models ERC45HG (ERC100HH) can have a short or long frame. See Battery Specifications section for the battery compartment size and battery specifications.



WARNING

The battery must fit the battery compartment so that the battery restraint will operate correctly. A loose battery can cause serious injury and property damage if the lift truck overturns. Use spacers to prevent the battery from moving more than 13 mm (0.5 in.) forward or backward.



WARNING

Maximum clearance between the battery and battery compartment width is 13 mm (0.5 in.). Maximum clearance between the battery and the spacer plate is also 13 mm (0.5 in.). The Battery Specifications chart shows the minimum size compartment allowed.

The lift trucks are equipped with adjustable spacers in the battery compartment. See Figure 2. Add or remove shims from under the front spacer bar to control the movement of the battery in the forward and backward directions. Install an equal number of shims at each capscrew. Install the additional shims under the nuts of the capscrews (outside battery compartment). The spacers on each side of the battery can be adjusted to control the movement of the battery from side to side. Access to the nuts for the spacers for the sides of the battery is under the frame near the steer tires on all units. Tighten all capscrews. It can be necessary to install the side spacers facing the opposite direction for some batteries. If the spacers cannot be adjusted for a battery that is specified for this lift truck, see your Yale lift truck dealer for the correct spacers.

The weight of the battery is a large part of the counterweight system on an electric lift truck. Make sure that the battery is within the weight limits indicated on the Nameplate. Each model of lift truck has a cast-iron counterweight that provides the additional weight necessary for the indicated capacity. A slot in the overhead guard permits removal of the battery without removing the overhead guard.

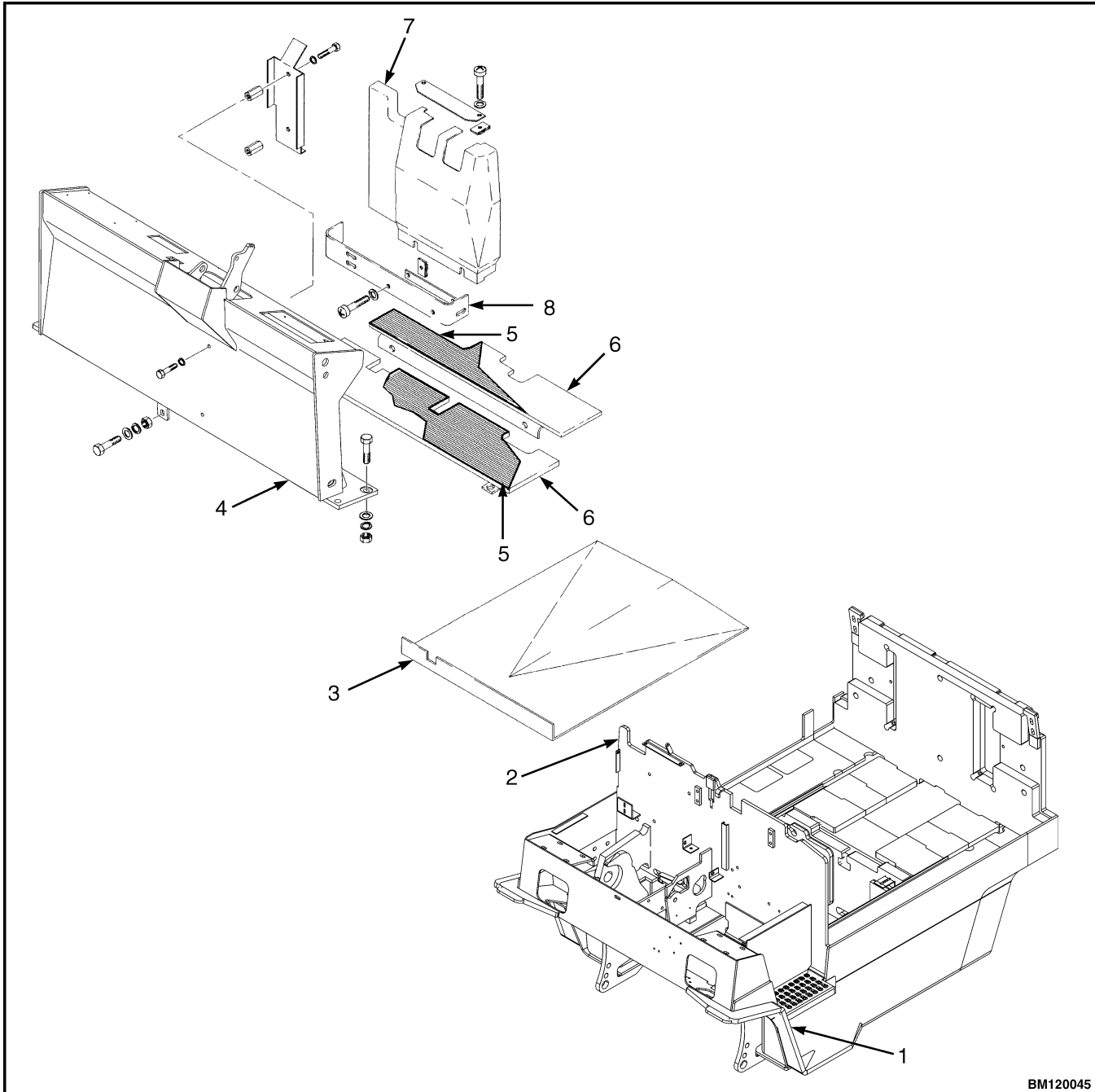

BM120045

- | | |
|----------------------------------|-----------------------------|
| 1. SIDE STEP AND FENDER WELDMENT | 5. FLOOR MAT |
| 2. FRAME | 6. FLOOR PLATE |
| 3. ACCESS PANEL | 7. COVER (HYDRAULIC LEVERS) |
| 4. COWL | 8. PLATE |

Figure 1. Lift Truck Frame, Floor Plates, and Covers

<https://www.ebooklibonline.com>

Hello dear friend!

Thank you very much for reading.

Enter the link into your browser.

The full manual is available for immediate download.

<https://www.ebooklibonline.com>

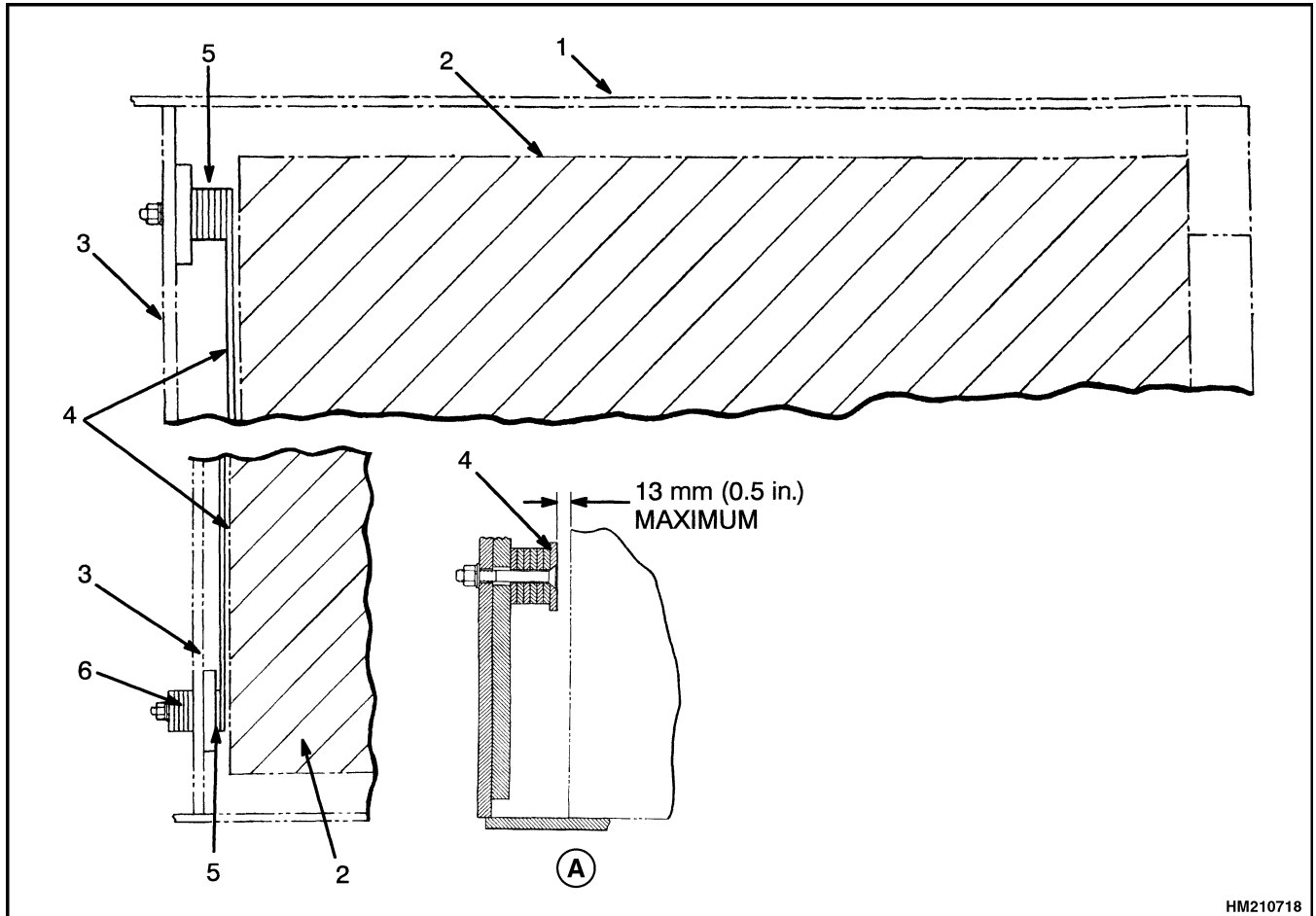

HM210718

A. FRONT SPACER

- | | |
|------------------------|--|
| 1. BATTERY COMPARTMENT | 5. SHIM |
| 2. BATTERY | 6. STORE ADDITIONAL SHIMS IN FRONT OF BULKHEAD |
| 3. BULKHEAD | |
| 4. SPACER BAR | |

Figure 2. Battery Spacer and Shims

Overhead Guard Replacement

REMOVE



WARNING

Do not operate the lift truck without the overhead guard correctly fastened to the lift truck.



WARNING

DO NOT weld mounts for lights or accessories to legs of the overhead guard. Changes that are made by welding, or by drilling holes that are too big or in the wrong location, can reduce the strength of the overhead guard.

See your dealer for Yale lift trucks **BEFORE** performing any changes to the overhead guard.

No welding or drilling on legs of overhead guard is permitted as per previous **WARNING**.

1. Remove battery as described in the section **Periodic Maintenance** 8000 YRM 1201. See the section Battery Specifications for information on battery weights and sizes.

2. Access to capscrews that hold rear supports of overhead guard to counterweight is from the battery compartment. Remove capscrews.
3. Remove two capscrews that hold each front support of overhead guard to cowl. Disconnect any electric wires from under cowl that go through supports of overhead guard. When overhead guard is lifted from the frame, make sure these electric wires move through the holes in the cowl so they are not damaged.
4. Use lifting device or another person to help lift overhead guard from lift truck.

INSTALL

1. Put overhead guard on lift truck. Install any electric wires from overhead guard supports through holes in cowl.
2. Install four capscrews, washers, and nuts that hold front supports to cowl.
3. Tighten capscrews to correct torque. Install capscrews and washers that hold rear supports to counterweight. Tighten capscrews to correct torque. The correct torque values are shown in Figure 3 and Table 1. Install battery.

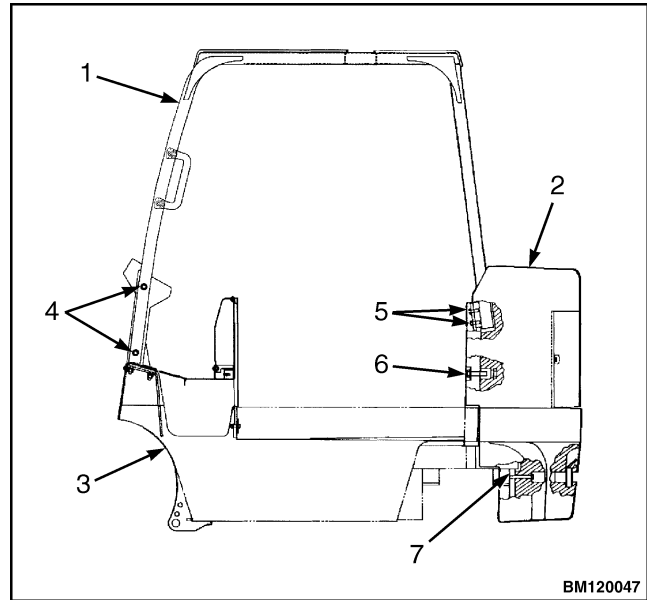

NOTE: OVERHEAD GUARD WITH CURVED LEGS SHOWN. OVERHEAD GUARD MAY BE EQUIPPED WITH STRAIGHT LEGS.

- | | |
|----------------------------|----------------------------|
| 1. OVERHEAD GUARD (OHG) | 5. CAPSCREWS (4) OHG-REAR |
| 2. COUNTERWEIGHT (CWT) | 6. CAPSCREWS (2) CWT-UPPER |
| 3. FRAME | 7. CAPSCREWS (2) CWT-LOWER |
| 4. CAPSCREWS (4) OHG-FRONT | |

Figure 3. Frame, Overhead Guard, and Counterweight

Table 1. Torque Values

Model	Overhead Guard		Counterweight	
	Front	Rear	Upper	Lower
ERC35-55HG (ERC70-120HH)	87 N•m (64 lbf ft)	87 N•m (64 lbf ft)	404 N•m (298 lbf ft)	66 N•m (49 lbf ft)

Battery and Operator Restraint, Hood and Seat Brake Repair

BATTERY RESTRAINT AND HOOD REPAIR

WARNING

The battery restraint and its latch mechanisms must operate correctly before a lift truck is operated. Make sure the battery has a cover if the lift truck does not have a hood.

A battery restraint system is installed as a safety device. See Figure 4. The function of the battery restraint system, when correctly locked in the down position, is to hold the battery in the battery compartment if an accident causes the lift truck to tip over. The battery restraint is a steel plate that is connected to the frame with a hinge. A sliding latch mechanism locks the battery restraint in the down position for operation. A knob near the hinge unlocks the battery restraint from the frame so the battery restraint can be raised to the up position for access to the battery. The battery restraint is also the support for the seat. A spring brace holds the seat and battery restraint in the up position. A battery retention bar is fastened to the counterweight with a hinge and is part of the hood. Spacers are used inside the battery compartment to prevent horizontal movement of the battery.

Legend for Figure 4

1. SEAT
2. BATTERY RESTRAINT PLATE
3. KNOB FOR LATCH MECHANISM
4. HINGE
5. LATCH
6. SPRING BRACE
7. BATTERY RETENTION BAR
8. HOOD

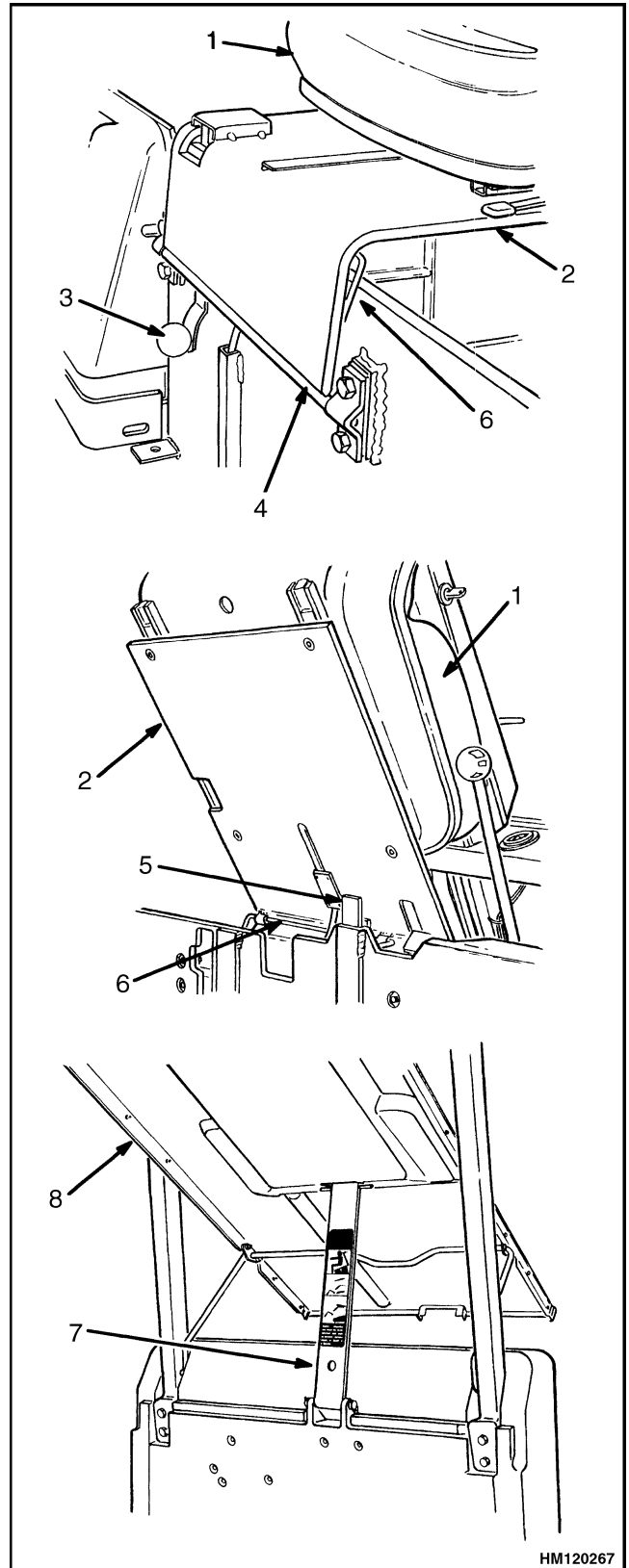

Figure 4. Battery Restraint and Seat Assembly

NOTE: The steering column must be in the forward position before raising the seat.

To raise the battery restraint and hood, the operator must hold the handle on the restraint plate (handle is located next to hip restraint on seat) with one hand and with the other hand, pull down on the knob for the latch mechanism to release the spring brace, and then raise the seat assembly and battery restraint plate toward the steering column. A spring brace will hold the assembly in the up position. With the seat assembly and battery restraint plate in the raised position, pull on the hood handles, located toward the rear of the hood, to raise the hood toward the counterweight. The hinged side plates must be flipped to the center of the truck before raising the hood. See Figure 5 and Figure 6.

Make sure that the battery cannot move more than a total of 13 mm (0.5 in.) in any one horizontal direction.

Make sure the correct spacers are installed to prevent the movement. See your Yale lift truck dealer to replace damaged or missing spacers. If a smaller battery of the correct weight (see Nameplate) is installed and the spacers cannot prevent movement, your Yale lift truck dealer has larger spacers.

To close the battery restraint and hood and to operate correctly, the battery restraint plate must be locked in the down position. Lower the battery retention bar first, then pull the release knob to release the up latch on the seat and lower the hood. Push the seat and the battery restraint down until the latch locks to lock the battery restraint plate in the down position over the bar. Lift on battery restraint to make sure it is latched securely to the frame and will not move.

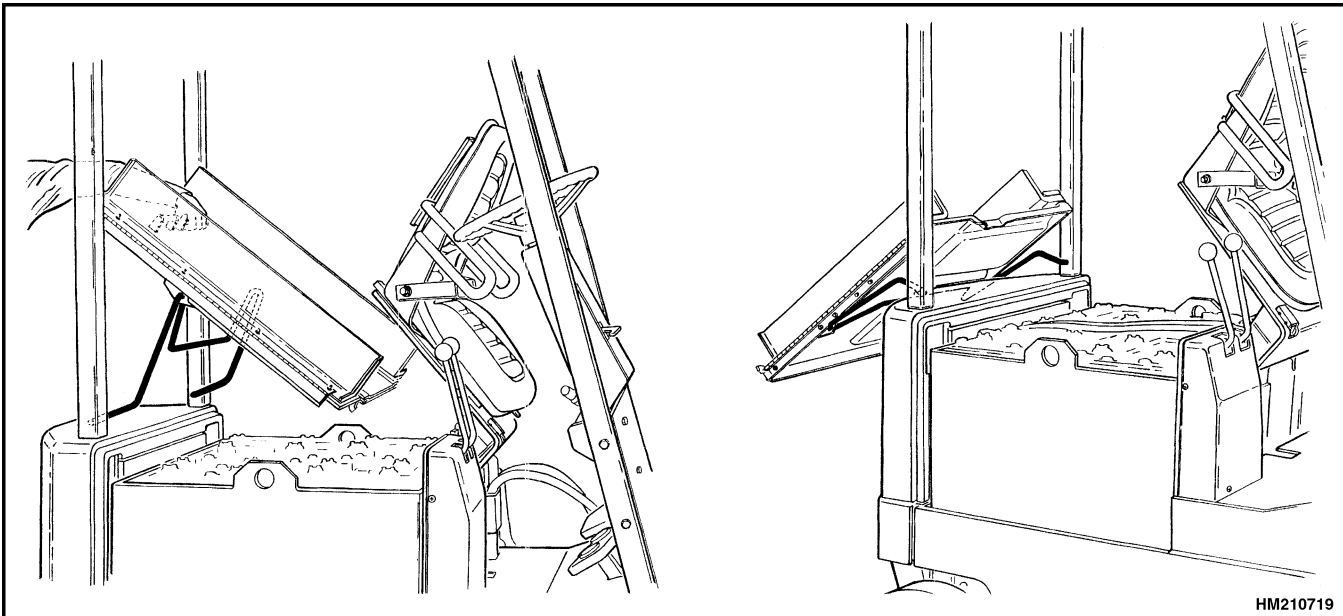
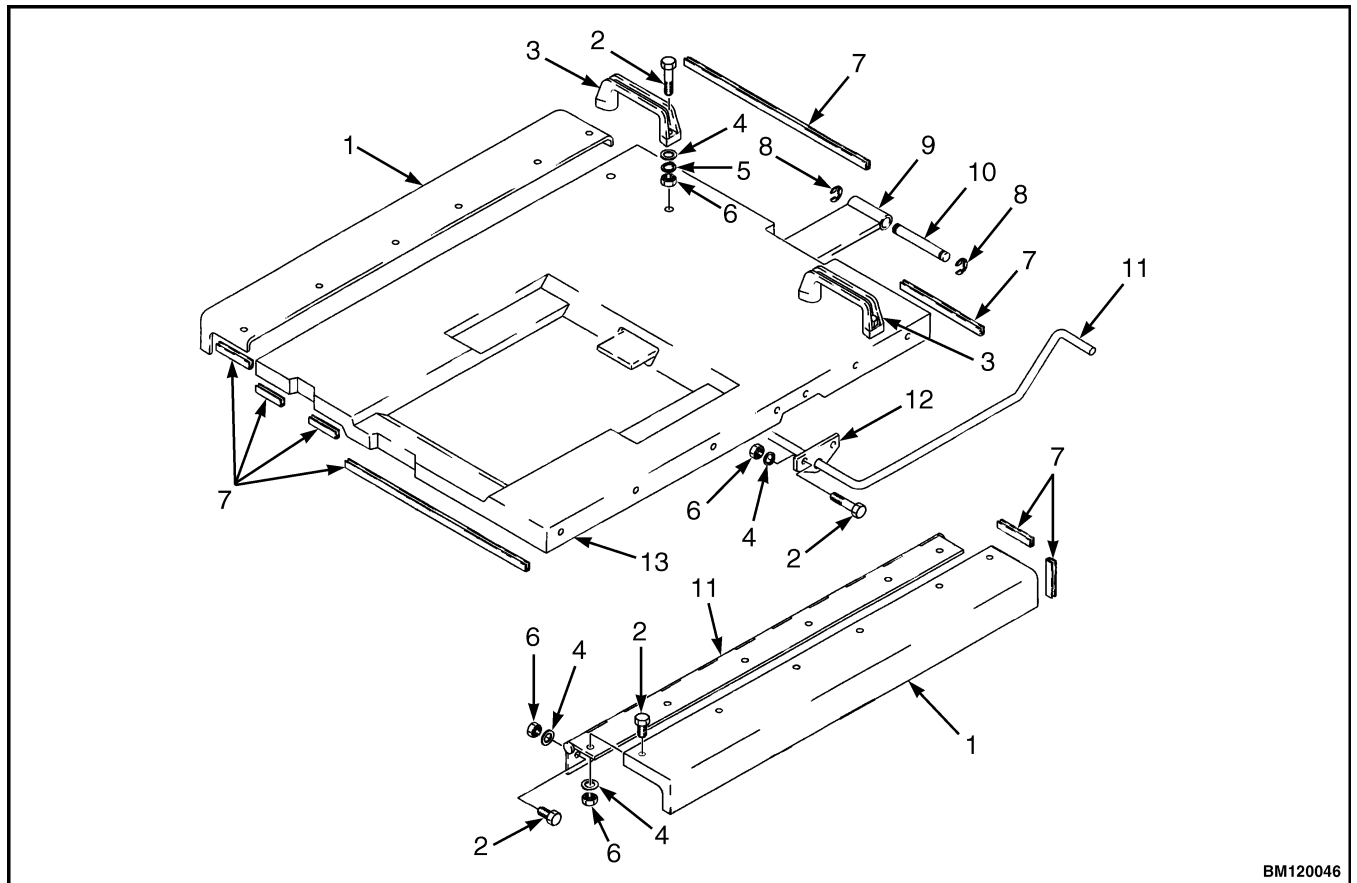

Figure 5. Open Hood



BM120046

- | | |
|-------------------------|--------------------------------------|
| 1. HINGED SIDE PLATES | 8. RETAINING RING |
| 2. CAPSCREW | 9. PLATE (FOR BATTERY RESTRAINT BAR) |
| 3. HOOD HANDLE (2) | 10. PIN |
| 4. WASHER | 11. HINGE |
| 5. LOCKWASHER | 12. BRACKET |
| 6. NUT | 13. HOOD |
| 7. ADHESIVE TRIM (SEAL) | |

Figure 6. Hood Assembly

OPERATOR RESTRAINT SYSTEM AND SEAT ASSEMBLY

The seat belt, hip restraint brackets, seat and mounting, hood, and latches are all part of the operator restraint system. Each item must be checked to make sure it is attached securely, functions correctly, and is in good condition. See Figure 7.

Automatic Locking Retractor (ALR)

NOTE: Lift trucks produced before November 2005 are equipped with the ALR type seat belts.

The seat belt must fasten securely. Make sure the seat belt extends and retracts smoothly and is not frayed or torn. If the seat belt is damaged or does not operate properly, it must be replaced. See Figure 7.

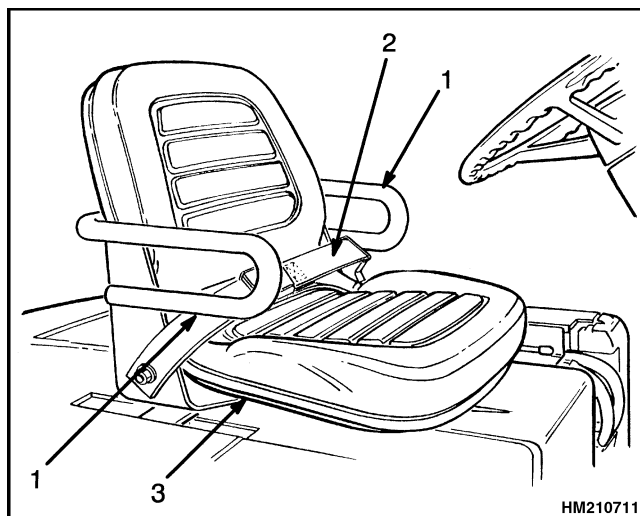

- | | |
|---------------------------|---------------|
| 1. HIP RESTRAINT BRACKETS | 2. SEAT BELT |
| | 3. SEAT RAILS |

Figure 7. Operator Restraint System

Emergency Locking Retractor (ELR)

NOTE: Lift trucks produced after November 2005 are equipped with the Emergency Locking Retractor (ELR) style seat belt.

When the ELR style seat belt is properly buckled across the operator, the belt will permit slight operator repositioning without activating the locking mechanism. If the truck tips, travels off a dock, or comes to a sudden stop, the locking mechanism will be activated and hold the operator's lower torso in the seat.

A seat belt that is damaged worn or does not operate properly will not give protection when it is needed. The

end of the belt must fasten correctly in the latch. The seat belt must be in good condition. Replace the seat belt if damage or wear is seen. See Figure 8.

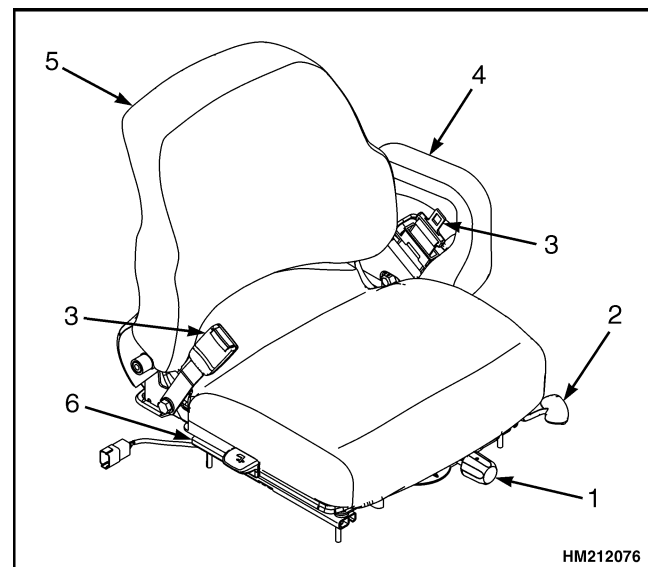

1. OPERATOR WEIGHT ADJUSTMENT
2. FORWARD/BACKWARD ADJUSTMENT
3. SEAT BELT
4. HIP RESTRAINT
5. SEAT
6. SEAT RAIL

Figure 8. Hood and Seat Check

The following seat belt operation checks must be performed:

- With the hood closed and in the locked position, pull the seat belt slowly from the retractor assembly. Make sure the seat belt pulls out and retracts smoothly. If the seat belt cannot be pulled from the retractor assembly or the belt will not retract, replace the seat belt assembly.
- With the hood closed and in the locked position, pull the seat belt with a sudden jerk. Make sure the seat belt will not pull from the retractor assembly. If the seat belt can be pulled from the retractor, when it is pulled with a sudden jerk, replace the seat belt assembly.
- With the hood in the open position, make sure the seat belt will not pull from the retractor assembly. If the seat belt can be pulled from the retractor, with the hood in the open position, replace the seat belt assembly.

Make sure the seat rails and latch striker are not loose. The seat rails must lock securely in position but move freely when unlocked. The seat rails must be securely attached to the mounting surface. The hood must be

fully closed. Lift the hood to make sure it is closed and will not move.

SEAT BRAKE REPAIR

See the section **Brake System** 1800 YRM 338 for the procedures for the seat brake.

Counterweight Replacement

NOTE: If the lift truck must be put on blocks for maintenance and repair, see the section **How to Put a Lift Truck on Blocks** in the **Operating Manual** or in the section **Periodic Maintenance** 8000 YRM 1201.

WARNING

The counterweight is very heavy. Make sure that the crane and lifting devices have enough lifting capacity to safely lift the counterweight. The weights of the counterweights are shown in Table 2.

The counterweight normally is not removed for most repairs. Replacement of the AC controllers is accomplished by removing the cover from the counterweight. See Figure 9. The counterweight is fastened to the frame with four capscrews. The weights for the counterweights are shown in Table 2.

Table 2. Weight of Counterweights

Model	Weight*
ERC35HG (ERC070HH)	822 kg (1812 lb)
ERC40-45HG (ERC080-100HH) (Long Frame)	1253 kg (2762 lb)
ERC45HG (ERC100HH) (Short Frame)	1912 kg (4215 lb)
ERC55HG (ERC120HH)	1912 kg (4215 lb)
* ±50 kg (110 lb)	

REMOVE

1. Remove battery. See **How to Change the Battery** in the section **Periodic Maintenance** 8000 YRM 1201. See Battery Specifications section for information on battery weights and sizes.
2. Remove overhead guard as described in the paragraphs under Overhead Guard Replacement.
3. Install lifting eyebolt in hole on top of counterweight. See Figure 9. Attach chain or sling to eyebolt. Use crane to hold the weight of the counterweight.

CAUTION

To prevent damage to the controller when removing the counterweight, carefully lift counterweight upward until it is off the frame, then straight back from the lift truck.

4. From inside the battery compartment, remove two capscrews that hold counterweight to frame. Remove two capscrews from tow pin area of counterweight. Use crane to lift counterweight away from frame. Make sure you do not damage the electronic controls.

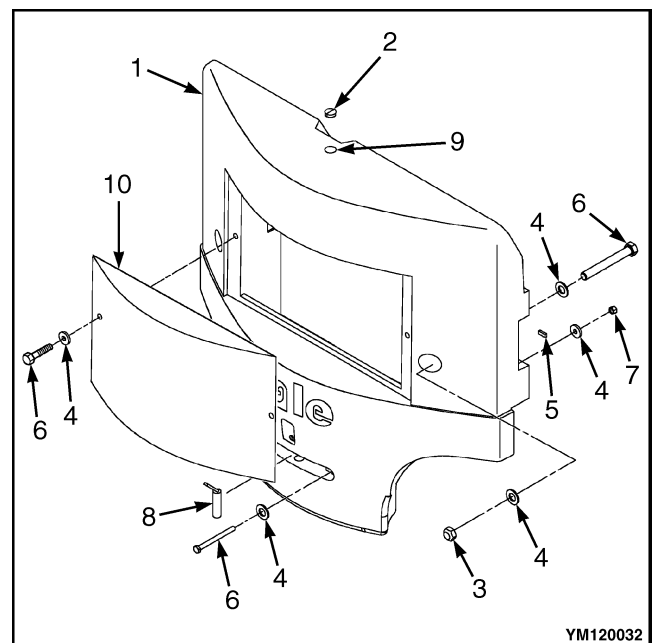

- | | |
|------------------|-----------------------|
| 1. COUNTERWEIGHT | 7. LOCK NUT |
| 2. PLUG | 8. TOW PIN |
| 3. NUT | 9. EYEBOLT HOLE |
| 4. WASHER | 10. CONTROLLERS COVER |
| 5. TAPE | |
| 6. CAPSCREW | |

Figure 9. Counterweight Assembly

INSTALL**CAUTION**

To prevent damage to the controller when installing the counterweight, carefully move the counterweight to the lift truck slightly above the frame, then lower the counterweight to the frame.

NOTE: The access panel to the controller can be removed from the counterweight to make checks and adjustments on the controller. Make sure lugs are correctly engaged when access panel is installed again or panel will fall from counterweight during operation.

1. Use crane to lift counterweight into position. Make sure you do not damage controller. Install two

upper capscrews from inside battery compartment that hold counterweight to frame. Install two lower capscrews in tow pin area of counterweight. Tighten capscrews to correct torque. The correct torque values for capscrews are shown in Table 1.

2. Disconnect sling or chain. Remove eyebolts from counterweight.
3. Install overhead guard as described in the paragraphs for Overhead Guard Replacement.
4. Install battery. See **How to Change the Battery** in the section **Periodic Maintenance** 8000 YRM 1201. See Battery Specifications section for information on battery weights and sizes.

Traction Motor Repair**REMOVE**

This procedure will show the removal of the traction motor through the battery compartment. The lift trucks covered in this manual can have an optional seat brake that actuates the brake on the armature shaft of the traction motor. See Figure 10. The guide pipe connection and electrical connections for the seat brake must be disconnected from the traction motor before the motor is removed. See the section **Brake System** 1800 YRM 338 for seat brake adjustment procedures.

NOTE: The traction motor can also be removed from under the lift truck with the use of a floor jack, but is more difficult. The lift truck must be on blocks with clearance for the jack and traction motor if the traction motor is removed from under the lift truck. See the section **How to Put a Lift Truck on Blocks** in the **Operating Manual** or in the section **Periodic Maintenance** 8000 YRM 1201. The hydraulic lines from the hydraulic tank must also be disconnected if the traction motor is removed from under the lift truck.

Legend for Figure 10

NOTE: TRACTION MOTOR WITH OPTIONAL SEAT BRAKE SHOWN.

1. GUIDE PIPE CONNECTION
2. ELECTRICAL CONNECTION
3. SEAT BRAKE

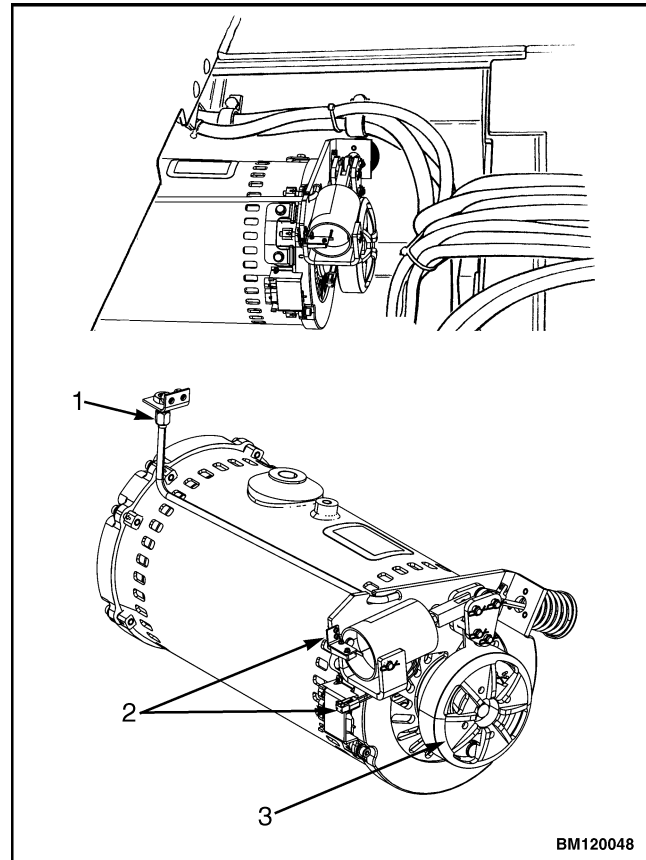

Figure 10. Traction Motor and Seat Brake

1. Remove battery as described in the section **Periodic Maintenance** 8000 YRM 1201. Remove floor plates and access panel in bottom of battery compartment. See Figure 1.

2. If lift truck is equipped with a seat brake, disconnect seat brake guide pipe and electrical connections (see Figure 10). Disconnect hydraulic line to main control valve so motor mount can be disconnected. Put caps on open hydraulic fittings.
3. Disconnect power cables from traction motor. Mark the cables and terminals for ease of reconnecting.
4. Put lift truck on blocks for easier access to bottom bolts between traction motor and speed reducer. Remove bolts between speed reducer and motor.

WARNING

Make sure the sling and crane can support the weight of the traction motor. The traction motor on these lift trucks weighs approximately 204 kg (450 lb). Make sure the sling cannot slide and permit traction motor to fall and cause injury.

5. Install sling to hold traction motor. See Figure 11. Use wood block and board under sling as shown in Figure 11. Use crane to hold weight of traction motor. See Figure 12.

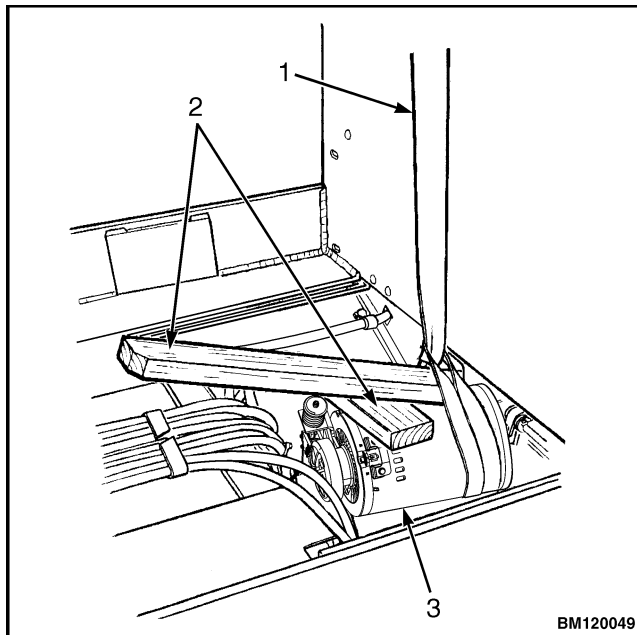

NOTE: TRACTION MOTOR WITH OPTIONAL SEAT BRAKE SHOWN.

1. SLING
2. USE WOOD BLOCK AND BOARD UNDER SLING FOR A LEVER
3. TRACTION MOTOR

Figure 11. Sling Installation to Lift Traction Motor

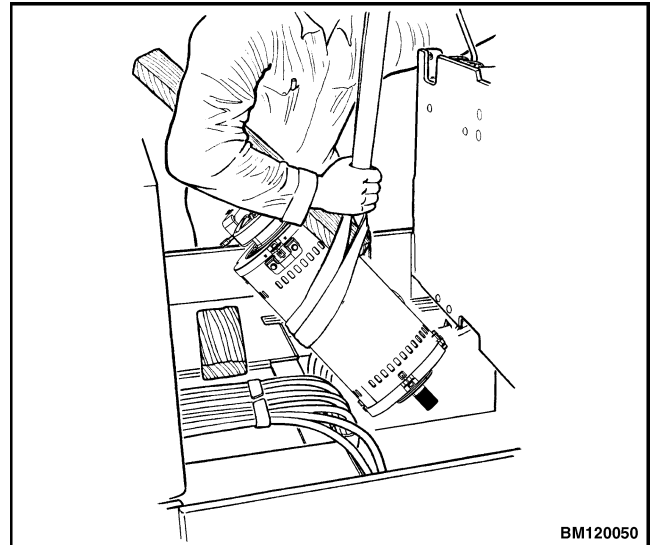

NOTE: TRACTION MOTOR WITH OPTIONAL SEAT BRAKE SHOWN.

Figure 12. Use Crane to Lift Traction Motor

6. Remove motor mount that holds traction motor to frame. Pull traction motor from speed reducer.
7. Use crane to move traction motor to a space to make repairs.

INSTALL

1. Install sling to lift traction motor. Use wood block and board under sling as shown in Figure 11 to control traction motor during installation.
2. Lower traction motor into position in lift truck. Align traction motor with speed reducer. See Figure 11.
3. Use board or pry bar as necessary to push traction motor into speed reducer.
4. Align bolt holes in speed reducer and motor housing. Install bolts that hold traction motor to speed reducer. Tighten bolts to 38 N•m (28 lbf ft).
5. Remove sling and install traction motor mount.
6. Connect inlet hydraulic line to main control valve. Install power cables.
7. If seat brake was removed, connect seat brake guide pipe and electrical connections. See Figure 10.

- Install floor plates and access panel in bottom of battery compartment. See Figure 1. Install battery

as described in the section **Periodic Maintenance** 8000 YRM 1201.

Hydraulic Tank Repair

INSPECT

Make a visual inspection of all sides of the tank. Inspect welds for cracks and leakage. Check for wet areas, accumulation of dirt, and loose or missing paint caused by leakage. Areas of the tank that are not easily seen can be checked with an inspection mirror and a light that is approved for locations with flammable vapors.

The hydraulic tank is part of the frame weldment and cannot be removed from the lift truck. See Figure 13. Repairs for leaks in the hydraulic tank can require special procedures described in the next paragraphs.

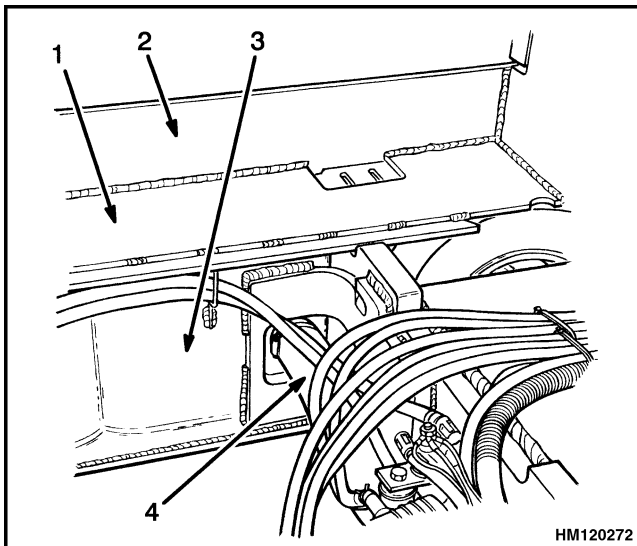

- | | |
|-------------------|-----------------|
| 1. HYDRAULIC TANK | 3. INNER FRAME |
| 2. OUTER FRAME | 4. SUCTION PIPE |

Figure 13. Hydraulic Tank

SMALL LEAKS, REPAIR

Use the following procedure to seal small leaks:

- Use steam to clean area around leak. Remove all paint and dirt around leak.

WARNING

Do not use tools that can make sparks, heat, or static electricity. The vapors in the tank can cause an explosion.

- Apply Loctite® 290 to leak. Follow instructions of manufacturer.

LARGE LEAKS, REPAIR

- Use one of the procedures described under Clean in this section to clean and prepare the tank for repairs.
- Use acceptable welding practices to repair tank. See the American National Standard *Safety In Welding and Cutting* AWS Z 49.1 - 1999.

CLEAN

WARNING

Special procedures must be followed when large leaks or other repairs need welding or cutting. All work must be done by authorized personnel. If the tank is cleaned inside of a building, make sure there is enough ventilation. See the following manuals for additional information:

- **Safe Practices for Welding and Cutting Containers That Have Held Combustibles** by the American Welding Society, F4.1 - 1999.
- **Safety In Welding and Cutting**, American National Standard, AWS Z 49.1 - 1999.

When cleaning tank, do not use solutions that make dangerous gases at normal temperatures or when heated. Wear eye and face protection. Protect the body from burns.

When cleaning with steam, use a hose with a minimum diameter of 19 mm (0.75 in.). Control the pressure of the steam by a valve installed at the nozzle of the hose. If a metal nozzle is used, it must be made of a material that does not make sparks. Make an electrical connection between nozzle and tank. Connect ground wire to tank to prevent static electricity.

Steam Method

Use the following procedure to clean the tank with steam:

1. Remove all parts from tank. Install drain plug.
2. Fill tank 1/4 full with a solution of water and sodium bicarbonate or sodium carbonate. Mix 0.5 kg (1 lb) per 4 liter (1 gal) of water.



WARNING

Compressed air can move particles so that they cause injury to the user or to other personnel. Make sure that the path of the compressed air is away from all personnel. Wear protective goggles or a face shield to prevent injury to the eyes.

3. Mix solution in tank using air pressure. Make sure all surfaces on inside of tank are flushed with solution. Drain tank.
4. Put steam into tank until tank does not have odors and metal is hot. Steam vapors must come from all openings.
5. Flush inside of tank with boiling water. Make sure all loose material is removed from inside of tank.
6. Make inspection of inside of tank. If it is not clean, repeat Step 4 and Step 5 and make another inspection. When making inspections, use a light that is approved for locations with flammable vapors.
7. Put plugs in all openings in tank. Wait 15 minutes, then remove inlet and outlet plugs. Test a sample of the vapor with a special indicator for gas vapors. If the amount of flammable vapors is above the lower flammable limit, repeat the cleaning procedures.

Chemical Solution Method

If the tank cannot be cleaned with steam, use the following procedure:

1. Mix a solution of water and trisodium phosphate or a cleaning compound with an alkali base. Follow the instructions given by the manufacturer.



WARNING

Compressed air can move particles so that they cause injury to the user or to other personnel. Make sure that the path of the compressed air is away from all personnel. Wear protective goggles or a face shield to prevent injury to the eyes.

2. Fill tank with cleaning solution. Use compressed air to mix solution in tank.
3. Drain tank. Flush inside of tank with hot (boiling) water. Make sure all cleaning compound is removed.
4. Make an inspection of inside of tank. If tank is not clean, repeat Step 1 through Step 3. Make another inspection of tank. When making inspections, use a light that is approved for locations with flammable vapors.
5. Check tank for flammable vapors using a special indicator for gas vapors. If the amount of flammable vapors is above the lower flammable limit, repeat the cleaning procedures.

ADDITIONAL PREPARATIONS FOR REPAIR

If nitrogen gas or carbon dioxide gas is available, prepare the tank for welding using these gases. See the manual *Safe Practices For Welding and Cutting Containers That Have Held Combustibles* by the American Welding Society, F4.1 - 1999. If these gases are not available, another method using water can be used as follows:

1. Fill tank with water to just below the point where the work will be done. Make sure the space above the level of the water has a vent.
2. Use acceptable welding practices to repair tank. See the American National Standard "Safety in Welding and Cutting," AWS Z 49.1 - 1999.

Safety Label Replacement

If the labels or information plates are missing or have damage, they must be replaced. See Figure 14.



WARNING

WARNING or CAUTION labels must be replaced if they are damaged. If a mast of a different size or an accessory carriage is installed, the capacity rating can change. Changes in the kind of drive tires can change the capacity rating. See a YALE Dealer for a replacement Nameplate. The Nameplate information is a safety item and must be correct for the equipment and configuration of the lift truck.

NOTE: The Nameplate is installed using rivets. The old rivets must be removed before installing a new Nameplate.

1. Make sure surface is dry and has no oil or grease. Do not use solvent on new paint. Clean surface of old paint using a cleaning solvent.
2. Remove paper from back of label. Do not touch adhesive surface.
3. Carefully hold label in correct position above surface. The label cannot be moved after it touches the surface. Put label on surface. Make sure all air is removed from under label and corners and edges are tight.

Legend for Figure 14

NOTE: INSTALL NEW LABEL IN SAME LOCATION AS ORIGINAL.

NOTE: NOT ALL LABELS USED ON THESE LIFT TRUCK MODELS ARE SHOWN IN FIGURE 14. SEE THE **PARTS MANUAL** FOR A COMPLETE LISTING OF ALL LABELS USED ON THESE LIFT TRUCKS.

- | | |
|---|-------------------------------------|
| 1. PINCH POINT LABEL | 13. EMERGENCY BATTERY DISCONNECT |
| 2. MAST WARNING | 14. AUXILIARY FUNCTION |
| 3. IMPACT RATING PLATE (OVERHEAD GUARD) | 15. PARKING BRAKE WARNING |
| 4. OPERATOR WARNING | 16. MAST WARNING |
| 5. LIFT/TILT LABEL | 17. FORWARD/REVERSE LABEL |
| 6. OPERATOR RESTRAINT | 18. NAMEPLATE LABEL |
| 7. NO RIDERS | 19. NAMEPLATE |
| 8. UL CLASSIFICATION PLATE (US TRUCKS ONLY) | 20. RIVET |
| 9. BATTERY RESTRAINT | 21. JOYSTICK AUXILIARY FUNCTIONS |
| 10. LIFTING EYE LABEL (EUROPEAN TRUCKS ONLY)* | 22. MINI-LEVERS AUXILIARY FUNCTIONS |
| 11. BATTERY SPACER WARNING | 23. WARNING BATTERY DISCONNECT |
| 12. UL CLASSIFICATION LABEL (US TRUCKS ONLY) | 24. CAUTION E-HYDRAULICS ARMREST |

***LABEL USED ON EUROPEAN MODELS ONLY.**

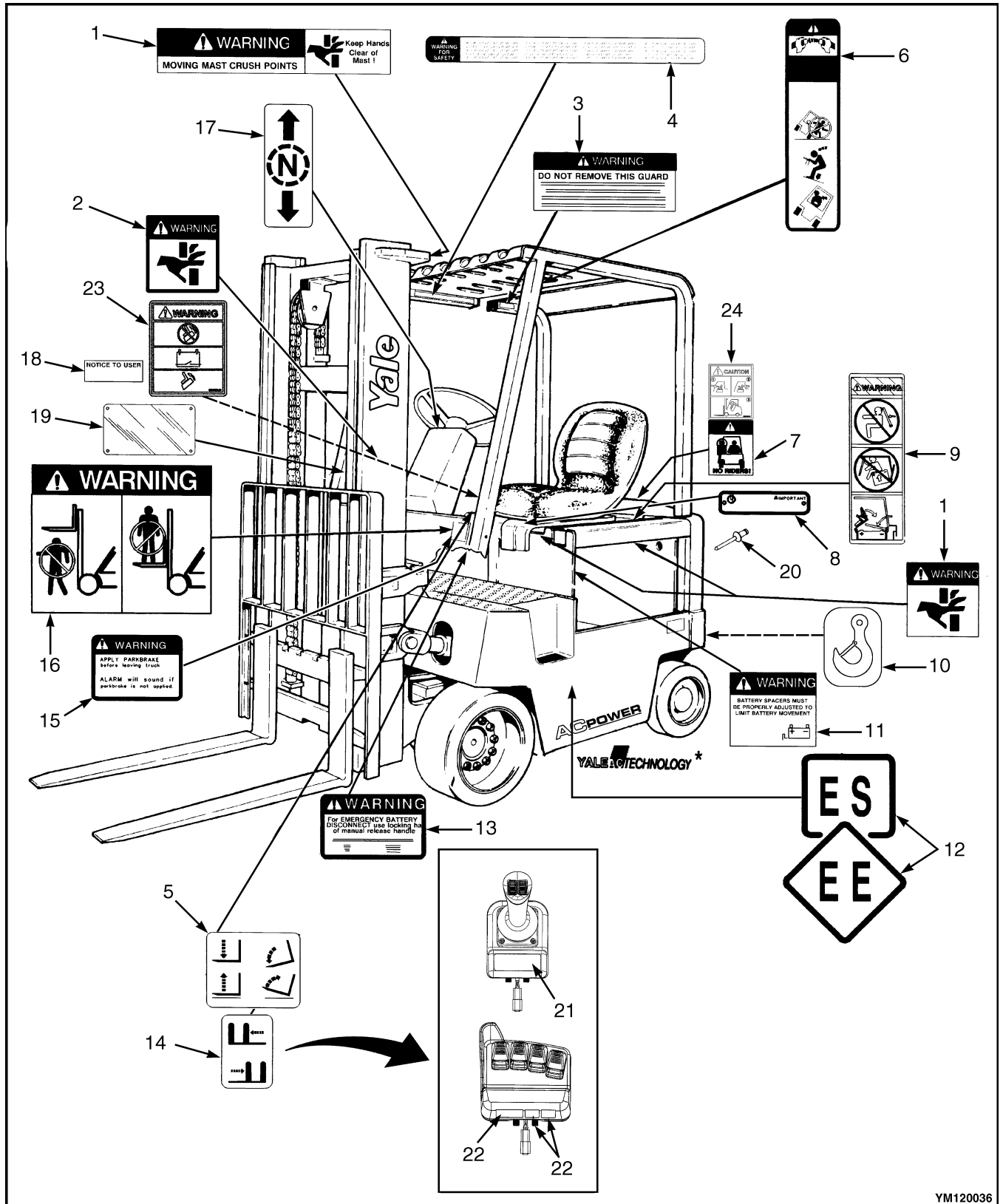

YM120036

Figure 14. Label Positions

Battery Specifications

Table 3. Battery Specifications*

Model	Volts	Minimum Compartment Size Length × Width	Battery Length	Weight	
			Min./Max.	Min.	Max.
ERC35-40HG(ERC070-080HH)	36, 48, 80	841 × 987 mm (33.1 × 38.9 in.)	950 to 990 mm (37.4 to 39.0 in.)	1542 kg (3400 lb)	2177 kg (4799 lb)
ERC45HG (E100HH) (Short Frame)	36, 48, 80	841 × 987 mm (33.1 × 38.9 in.)	950 to 990 mm (37.4 to 39.0 in.)	1633 kg (3600 lb)	2177 kg (4799 lb)
ERC45HG (ERC100HH) (Long Frame)	36, 48, 80	694 × 1037 mm (27.3 × 40.8 in.)	1115 to 1150 mm (43.9 to 45.3 in.)	1814 kg (4000 lb)	2517 kg (5681 lb)
ERC55HG (ERC120HH)	36, 48, 80	993 × 1146 mm (39.3 × 45.1 in.)	1115 to 1150 mm (43.9 to 45.3 in.)	1919 kg (4231 lb)	2517 kg (5681 lb)

*BATTERY WIDTH
 Batteries without cover: 950 to 1117 mm (37.4 to 44.0 in.)
 Batteries with cover: 950 to 1143 mm (37.4 to 45.0 in.)
NOTE: Maximum tolerances are +0 and –13 mm (+0 and –0.5 in.) for the size of the battery compartment. The battery specification chart shows the maximum size tolerances that will permit the battery to still fit into a battery compartment.

General

This section describes the disassembly, assembly, and inspection procedures and checks for malfunctions of AC motors.

AC traction motors and AC hydraulic pump motors are similar in design. See Figure 1. The AC hydraulic pump and AC steering pump motors are a smaller version of the AC traction motor. Disassembly and repair of these motors are similar.

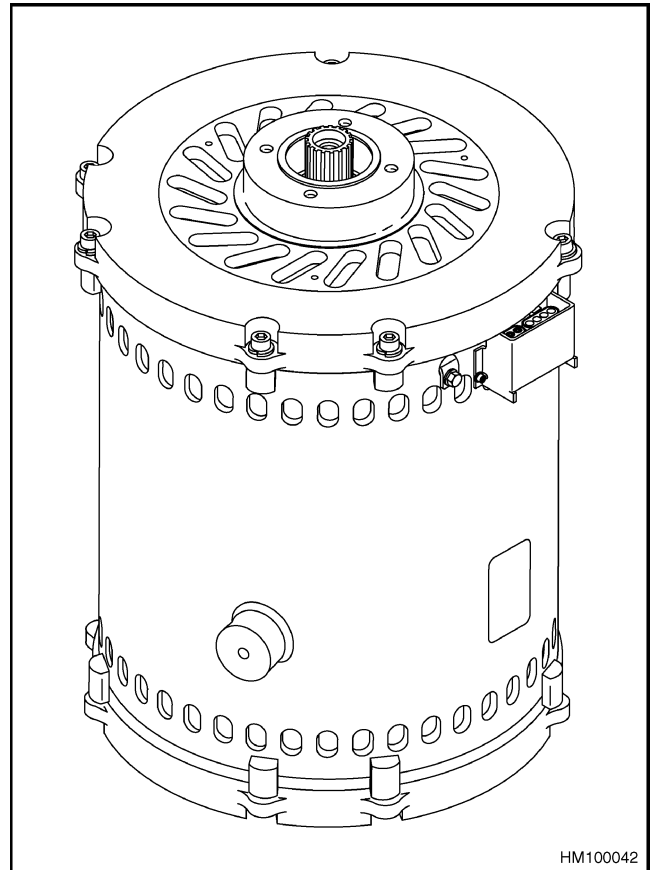

Figure 1. AC Traction Motor ERC20-32AGF (ERC040-065GH) (A908) Model Shown

AC Motor Repair

DISASSEMBLE



CAUTION

The bearings and seal on the AC traction motor are serviceable parts, while the only serviceable parts on the AC hydraulic pump motor are the bearings. **Be careful to not damage bearings when replacing.**

NOTE: When replacing one bearing, it is strongly recommended to replace both bearings and the seal of the AC traction motor.

1. Remove motor from the lift truck. See the **Frame YRM** for your lift truck model for removal information.



WARNING

The AC hydraulic pump motor can weigh as much as 113 kg (250 lb) and the AC traction motor can weigh as much as 204 kg (450 lb). **To prevent injury, use a lifting device capable of lifting the assembly.**

2. Screw lifting eye into the threaded hole in the end of the rotor shaft, and connect a chain to lifting eye. Attach approved lifting device and lift motor.
3. Place motor on level blocks on a flat surface with drive end pointing down. Remove approved lifting device and lifting eye. See Figure 1.
4. Remove connector cover. See Figure 2.

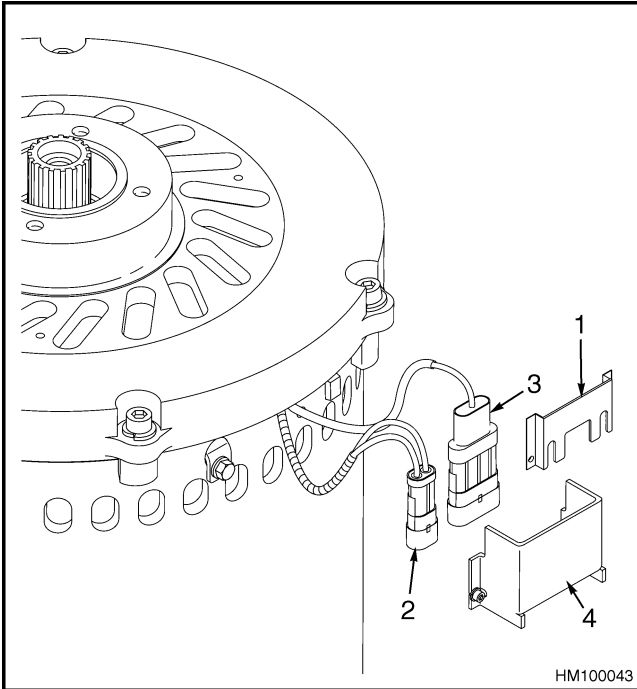

1. MOUNTING BRACKET
2. TEMPERATURE SENSOR
3. ENCODER BEARING CONNECTOR
4. CONNECTOR COVER

Figure 2. Connector Cover

5. Remove connectors from mounting bracket. See Figure 2.
6. Remove screws and retaining nuts from the end bell. See Figure 3.

CAUTION

Do not rotate the end bell. Lift end bell straight up enough to separate the bearing. If the end bell is pulled or lifted too high, damage will occur to the encoder wire.

7. With a rubber mallet, gently tap under the end bell and lift end bell straight up.
8. Support end bell with four small blocks and remove hex socket screws that attach air guide to the end bell. See Figure 4.
9. Remove end bell by lifting it straight up.
10. Pull rubber wire mount out of the stator. See Figure 5.
11. Separate encoder wire and temperature sensor wire from the rubber wire mount. See Figure 6.

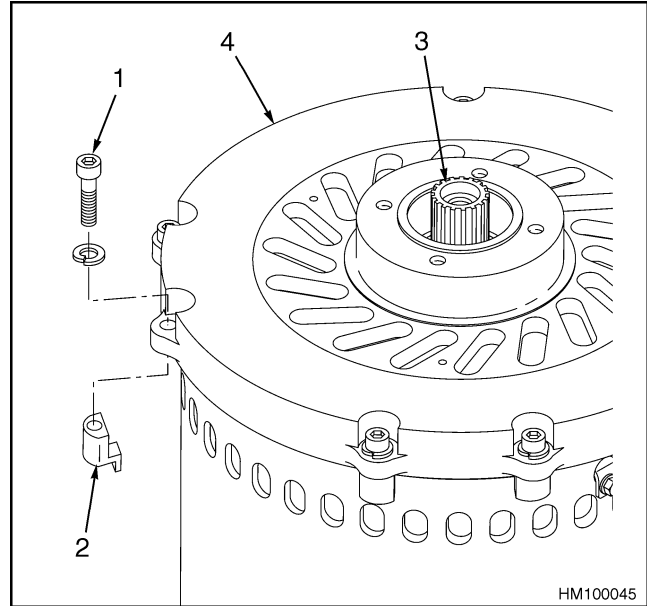

1. SCREW
2. RETAINING NUT
3. ROTOR SHAFT
4. END BELL

Figure 3. Removing Screws and Retaining Nuts From End Bell

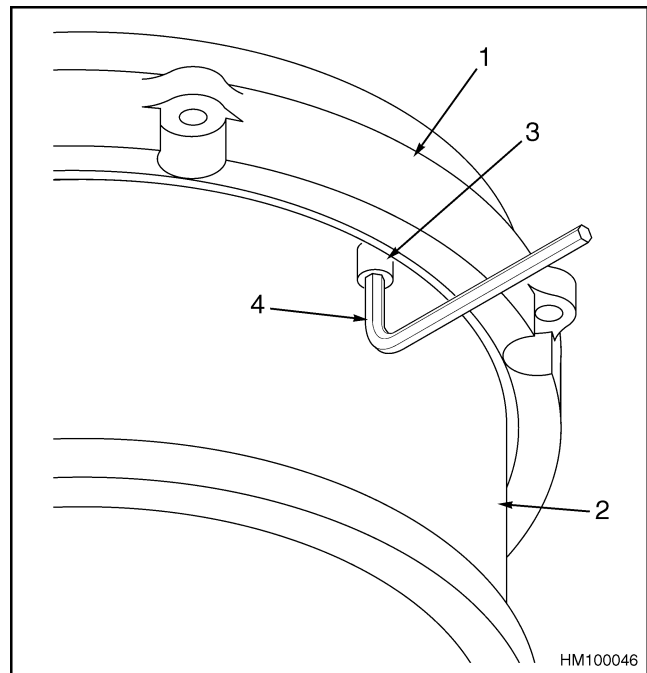

1. END BELL
2. AIR GUIDE
3. HEX SOCKET SCREW
4. HEX SOCKET SCREW WRENCH

Figure 4. Hex Socket Screws Removal

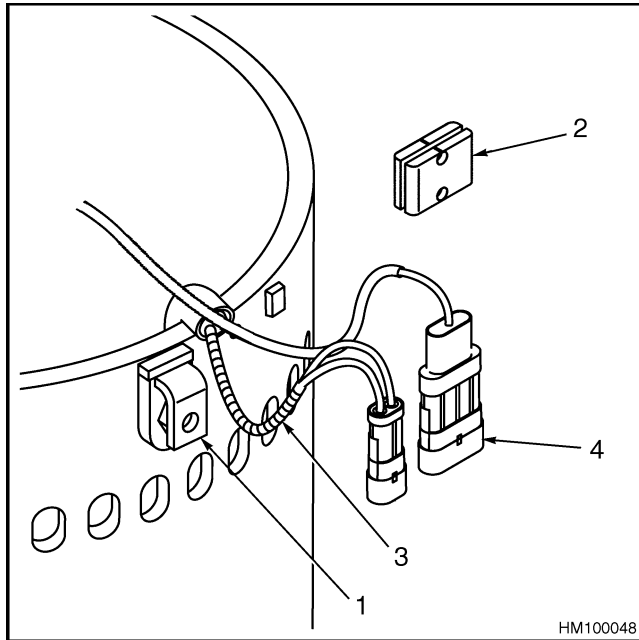

1. POWER TERMINAL
2. RUBBER WIRE MOUNT
3. TEMPERATURE SENSOR WIRE
4. ENCODER BEARING CONNECTOR

Figure 5. Rubber Wire Mount Removal

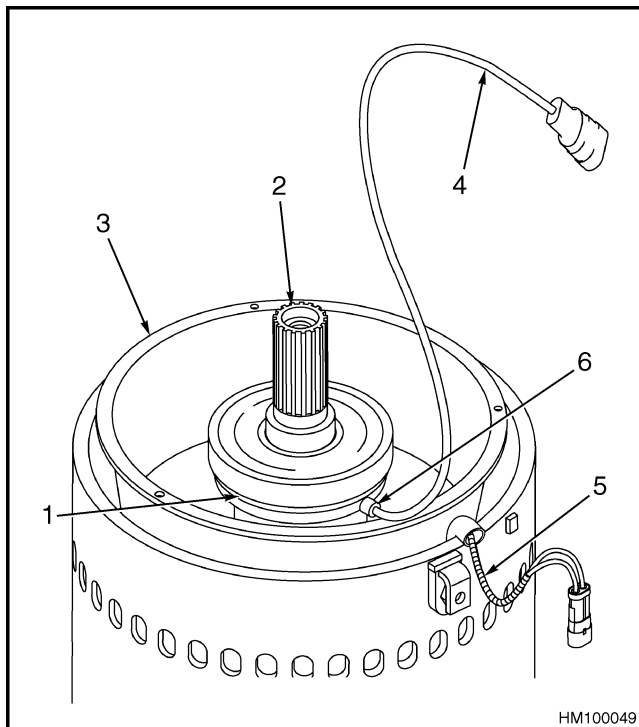

Figure 6. Separated Encoder Wire From Rubber Mount

Legend for Figure 6

1. ENCODER BEARING
2. ROTOR SHAFT
3. AIR GUIDE
4. ENCODER BEARING WIRE
5. TEMPERATURE SENSOR WIRE
6. ENCODER BEARING TANG

12. Remove the air guide. See Figure 7.

NOTE: Before removing the encoder bearing, note its orientation and install the new encoder bearing in the same orientation.

13. Using a bearing puller, remove encoder bearing. See Figure 8.

NOTE: Perform Step 14 for ERC/P16-20AAF (ERC030-040AH) (B814/C814) model only.

14. Remove the 3/4 inch hex socket plug from the end bell. See Figure 9.

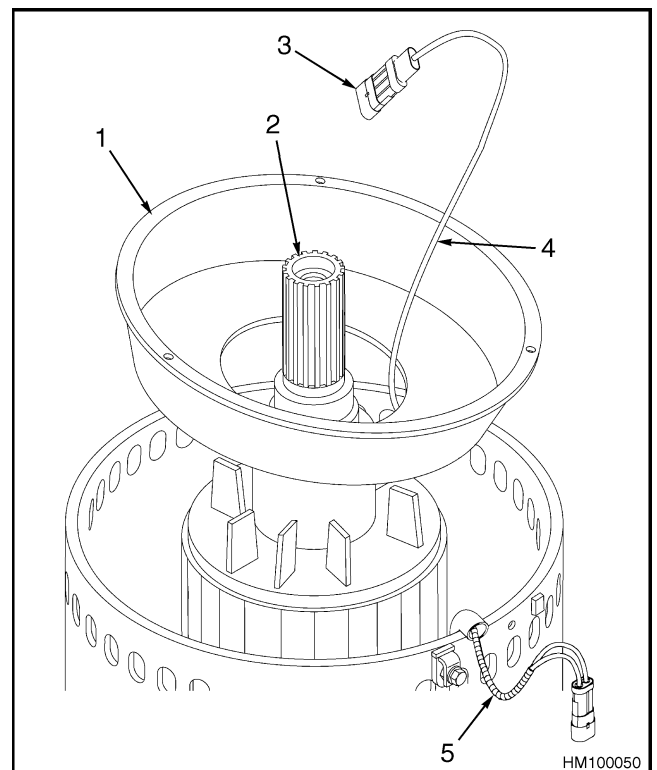

1. AIR GUIDE
2. ROTOR SHAFT
3. ENCODER BEARING CONNECTOR
4. ENCODER BEARING WIRE
5. TEMPERATURE SENSOR WIRE

Figure 7. Air Guide Removal

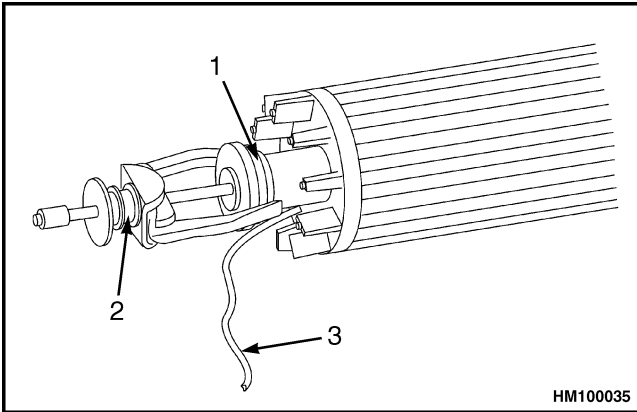

- 1. ENCODER BEARING
- 2. BEARING PULLER
- 3. ENCODER WIRE

Figure 8. Bearing Removal

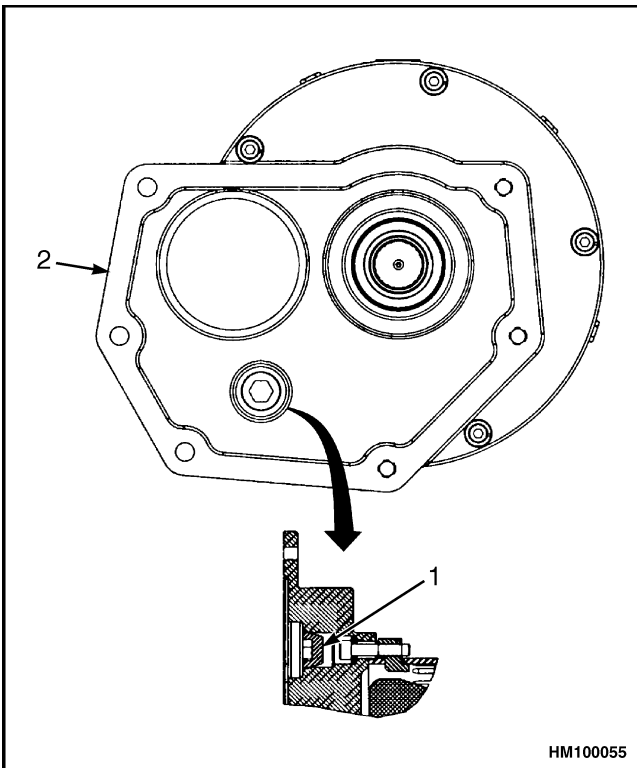

- 1. 3/4-INCH HEX SOCKET PLUG
- 2. END BELL

**Figure 9. End Bell ERCIP16-20AAF
(ERC030-040AH) (B814C814)**

15. Remove screws and retaining nuts from the drive end bell.

CAUTION

To prevent damage to the encoder wire, make sure the encoder wire is out of the way when lifting stator.

16. Attach approved lifting device to the stator, and slowly lift stator straight up from the rotor and drive end bell. See Figure 10.

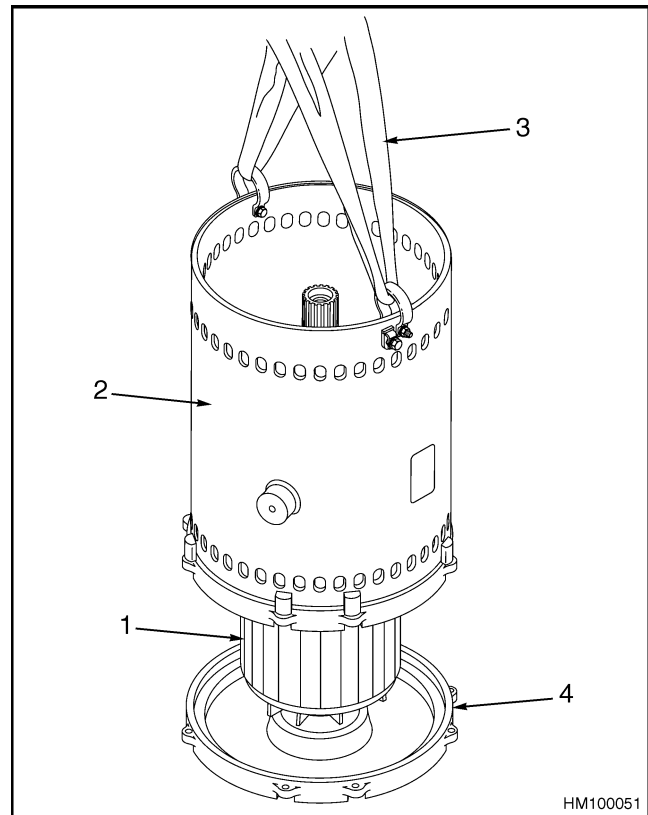

- 1. ROTOR
- 2. STATOR
- 3. APPROVED LIFTING DEVICE
- 4. DRIVE END BELL

**Figure 10. Lifting of Stator ERC20-32AGF
(ERC040-065GH) (A908) Model Shown**

NOTE: On the hydraulic pump motors there is a second air guide attached to the drive end bell. Remove screws from the second air guide so you are able to move the second air guide for access to the snap ring.

NOTE: On older lift truck models, the snap ring is between the rotor and drive end of end bell. You will need to feel with your fingers where the snap ring is located and attach the snap ring pliers. See Figure 11.

NOTE: On newer lift truck models, the snap ring is located in the drive end of the end bell. See Figure 11.

17. Remove snap ring. For older lift truck models, use snap ring pliers. See Figure 11.

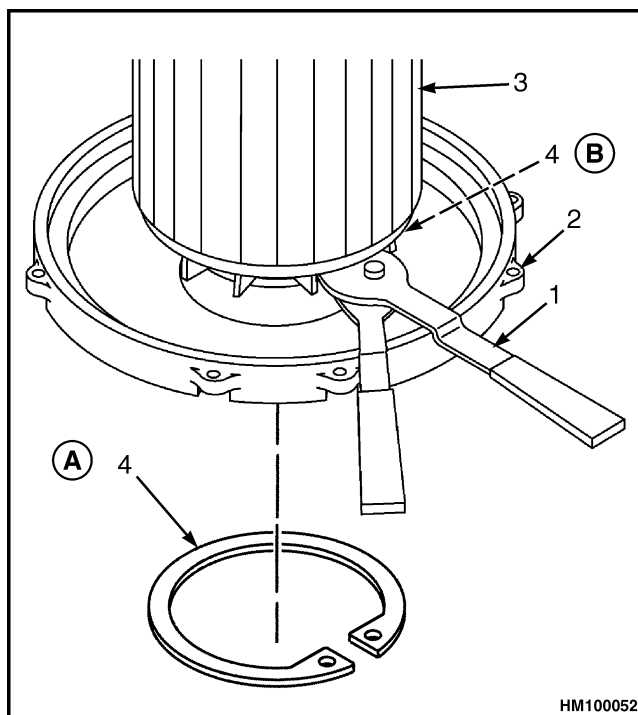

- A. LOCATION OF SNAP RING, NEWER LIFT TRUCK MODELS
 B. LOCATION OF SNAP RING, OLDER LIFT TRUCK MODELS
1. SNAP RING PLIERS
 2. DRIVE END BELL
 3. ROTOR
 4. SNAP RING

Figure 11. Snap Ring Removal ERC20-32AGF (ERC040-065GH) (A908) Model Shown

18. Screw lifting eye into the threaded hole in the end of the rotor shaft. Attach approved lifting device and lift rotor straight up from the drive end bell.

19. Using a bearing puller, remove bearing from drive end of rotor shaft.

20. Remove snap ring from shaft.

21. Using a seal driver, remove drive shaft seal from end bell.

ASSEMBLE

NOTE: Perform Step 1 for ERC/P16-20AAF (ERC030-040AH) (B814/C814) model only.

1. Lubricate the drive end bell seal shaft with multi-purpose grease using 2 to 4 percent molybdenum disulfide. See Figure 12.

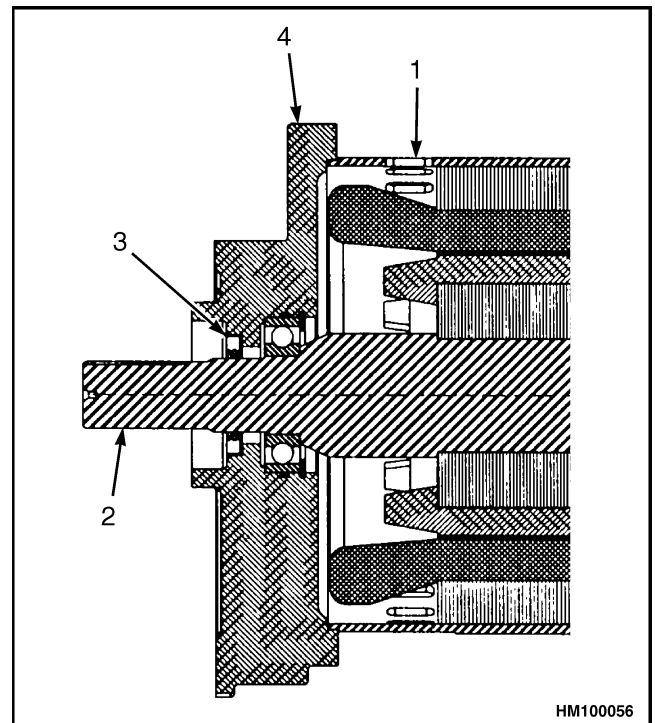

1. TRACTION MOTOR (SHOWN)
2. ROTOR ASSEMBLY
3. DRIVE END BELL SEAL SHAFT
4. DRIVE END HOUSING

Figure 12. Lubrication of Seal Shaft

2. Using a seal driver, install drive shaft seal, with lip seal towards the motor, in end bell.
3. On older lift truck models, place snap ring on rotor shaft with chamfered side toward the rotor. See Figure 11.
4. Install the bearing on the drive end of the rotor shaft using a bearing driver and arbor press.

 **CAUTION**

To avoid damage to the encoder bearing electronics, use a bearing driver and arbor press. Press only on the inner race of the bearing.

NOTE: The encoder bearing must be oriented as noted during removal.

5. Using a bearing driver and arbor press, install the encoder bearing as noted during removal. Press only on the inner race of the bearing during installation.
6. Attach lifting eye and lift rotor with approved lifting device. Lower rotor into drive end bell. Guide encoder wire into relief area to avoid damage. Make sure bearing is fully seated against drive end bell.
7. On older lift truck models, use snap ring pliers and install snap ring into groove. For newer lift truck models, install snap ring in drive end of the end bell. See Figure 11.
8. Remove approved lifting device and lifting eye from rotor.

 **CAUTION**

To avoid damage to the encoder wire, make sure the encoder wire is out of the way when lowering stator onto drive end bell.

9. Use approved lifting device and lift stator.

NOTE: Make sure holes for retaining nuts in stator are aligned with the holes for the retaining bolts in the drive end bell.

10. Lower stator straight onto drive end bell. See Figure 10.

11. Remove approved lifting device from stator.
12. Attach retaining bolts and nuts into stator and the drive end bell. Tighten retaining bolts and nuts to 25 to 30 N•m (221 to 265 lbf in). See Figure 3.

NOTE: Perform Step 13 for ERC/P16-20AAF (ERC030-040AH) (B814/C814) model only.

13. Install the 3/4 inch hex socket plug into the end bell to prevent oil leakage. See Figure 9.
14. Place encoder wire through air guide and lower air guide onto rotor shaft.
15. Place encoder wire and temperature sensor wire back into the rubber wire mount.
16. Place rubber wire mount back into stator.

NOTE: Make sure the spring washer is installed in the end bell. See Figure 13.

 **CAUTION**

To prevent damage to the encoder bearing, ensure encoder wire is inserted in encoder wire slot when air guide is attached to the end bell.

17. Insert encoder wire in the end bell slot and attach air guide to end bell. See Figure 13.

 **CAUTION**

To prevent damage to the encoder wire, line up encoder tang slot with encoder bearing tang.

18. For proper bearing alignment, see Figure 13. Lower the end bell straight down onto the rotor shaft.
19. Seat end bell completely onto shaft.
20. Attach screws and retaining nuts to the end bell.
21. Attach connectors to mounting bracket and attach connector cover and mounting bracket to stator. Tighten connector cover capscrews to 3.4 to 4.0 N•m (30 to 35 lbf in). See Figure 2.

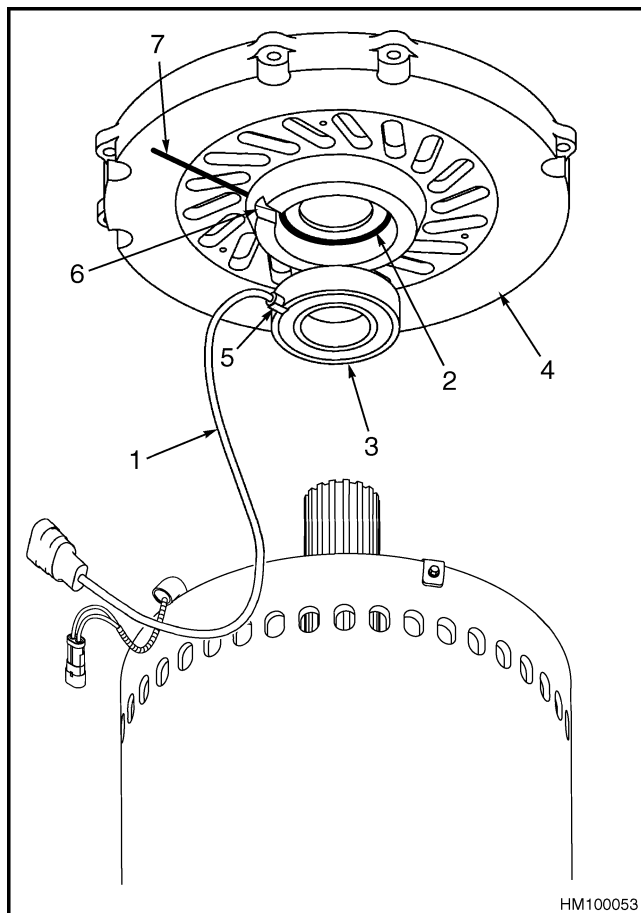

Legend for Figure 13

- 1. ENCODER WIRE
- 2. SPRING WASHER
- 3. ENCODER BEARING
- 4. END BELL
- 5. ENCODER BEARING TANG
- 6. ENCODER TANG SLOT
- 7. ENCODER WIRE SLOT

Figure 13. Alignment of Encoder Wire and Encoder Bearing Tang in End Bell Slot

Troubleshooting

PROBLEM	POSSIBLE CAUSE	PROCEDURE OR ACTION
Truck moves slow or in a jerky motion.	Encoder broken.	Replace encoder bearing.
	Encoder wire broken.	Check and repair encoder wire or replace encoder bearing.
Temperature sensor wire fails.		Measure resistance with ohmmeter. Resistance should be 530 ohms at 25 °C (77 °F). Repair temperature sensor wire. The temperature sensor wire can be repaired, but the temperature sensor cannot be repaired.

PROBLEM	POSSIBLE CAUSE	PROCEDURE OR ACTION
Stator wires fail.	Loss of insulation in wire.	Check resistance between winding and case. Resistance should be at 50,000 ohms or above.

General

This section has the description and repair procedures for the differential, speed reducer, drive axle, wheel bearings, and mounts for the axle housing.

Description

The drive axle assembly is fastened to the frame of the lift truck by separate mounts. See Figure 1. The drive axle assembly can rotate in the mounts. The outer ends of the axle housings are the spindles for the wheel bearings. The wheel bearings are tapered roller bearings with the cups pressed into the hubs. The nut on the end of the axle housing adjusts and holds the wheel bearings. The axle shafts are fastened to the hubs by

capscrews and two dowel pins. The back plate and brake assembly are fastened to the axle mounts. The axle housing also has bearing journals for the upright.

The outer wheel bearing is lubricated by gear oil from the differential housing. The inner wheel bearing is lubricated by wheel bearing grease.

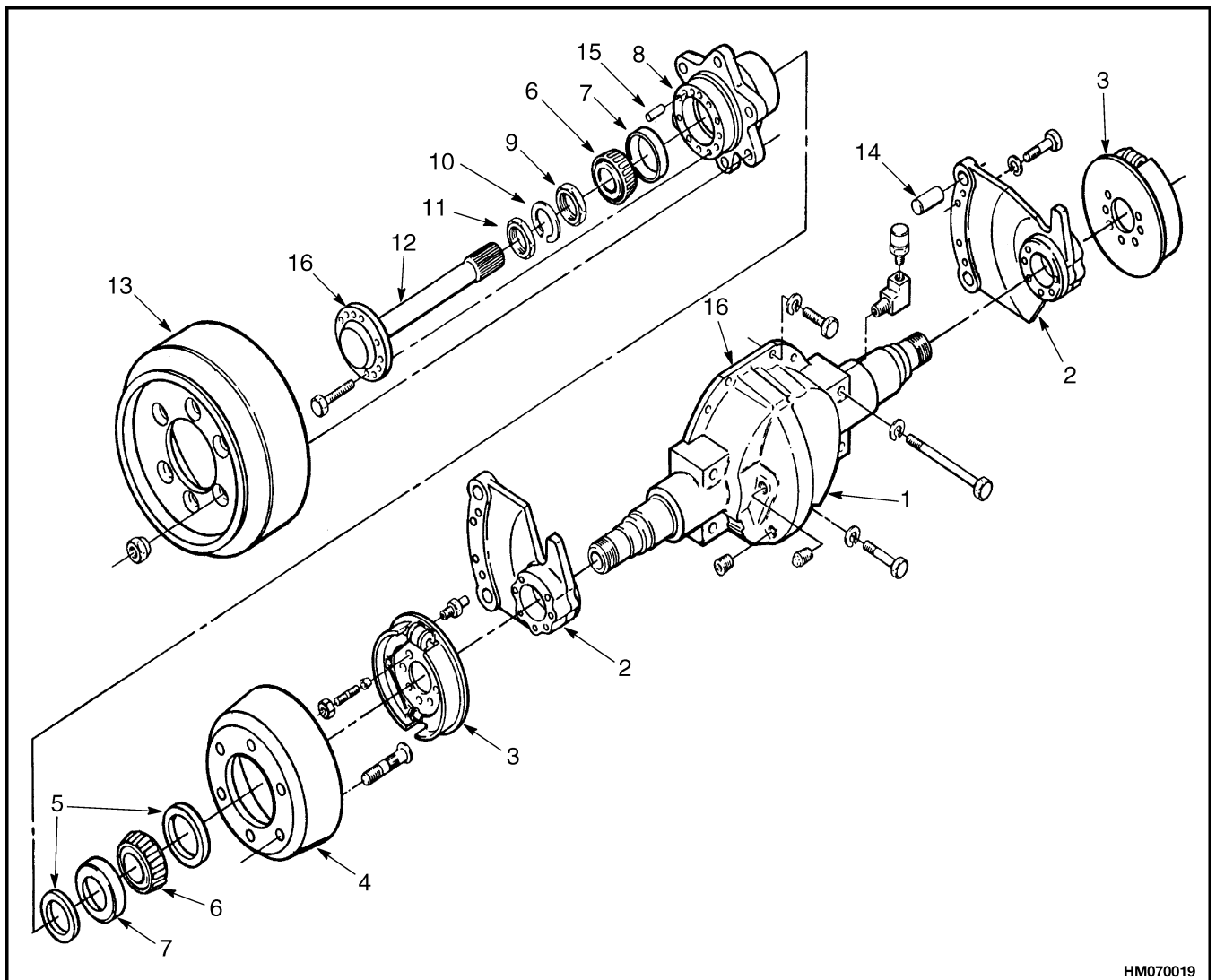

HM070019

Figure 1. Drive Axle Assembly

Legend for Figure 1

- | | |
|-------------------|--------------------|
| 1. AXLE HOUSING | 9. ADJUSTMENT NUT |
| 2. AXLE MOUNT | 10. LOCKWASHER |
| 3. BRAKE ASSEMBLY | 11. LOCK NUT |
| 4. BRAKE DRUM | 12. AXLE SHAFT |
| 5. SEAL | 13. TIRE AND WHEEL |
| 6. BEARING CONE | 14. MOUNTING PIN |
| 7. BEARING CUP | 15. DOWEL PIN |
| 8. HUB | |

Drive Axle, Speed Reducer, and Differential Repair

REMOVE

General

1. Remove mast assembly as described for lift truck models ERC070-120HD (A839) in section **Masts, Description and Repairs for Lift Trucks With 3,500 to 6,000 kg (7,000 to 12,000 lb) Capacities** 4000 YRM 340 or for models ERC070-120HG (A839) and ERC35-55HG (ERC70-120HH) (B839/C839) in section **Masts, Description and Repairs** 4000 YRM 736 for your specific lift truck.
2. Raise lift truck and put blocks under all four wheels. Drain oil from differential housing. See the section **Periodic Maintenance** 8000 YRM 915 for lift truck models ERC070-120HG (A839) or **Periodic Maintenance** 8000 YRM 1201 for lift truck models ERC35-55HG (ERC70-120HH) (B839/C839) under **How to Put Lift Truck on Blocks**.
3. Remove battery as described in the section **Periodic Maintenance** 8000 YRM 915 for lift truck models ERC070-120HG (A839) or **Periodic Maintenance** 8000 YRM 1201 for lift truck models ERC35-55HG (ERC70-120HH) (B839/C839) under **How to Change Battery**.

⚠ WARNING

The lift truck must be put on blocks for some types of maintenance and repair. The removal of the following assemblies will cause large changes in the center of gravity: attachment, mast, drive axle, battery, and counterweight.

When the lift truck is put on blocks, put additional blocks in the following positions:

- a. Before removing the mast and drive axle, put blocks under the counterweight so the lift truck cannot tip backward.

- b. Before removing the battery or counterweight, put blocks under the mast assembly so the lift truck cannot tip forward.

Put the lift truck on blocks only if the surface is solid, even, and level. Make sure that any blocks used to support the lift truck are solid, one-piece units.

4. Remove capscrews that hold axle shafts to hubs. There are two holes with threads in the flange of the axle shaft. Put capscrews (M16×2) in these holes to push axle shaft from hub. Or, hit end of axle shaft with a soft hammer. Remove axle shaft.

NOTE: For lift truck models ERC070-120HD/HG (A839) perform Step 5 and Step 6. For lift truck models ERC35-55HG (ERC70-120HH) (B839/C839), go to Step 7.

5. Hold seat in down position. Disconnect adjustment rod for seat brake at top connection. Lift rod out of brake lever. See Figure 2.

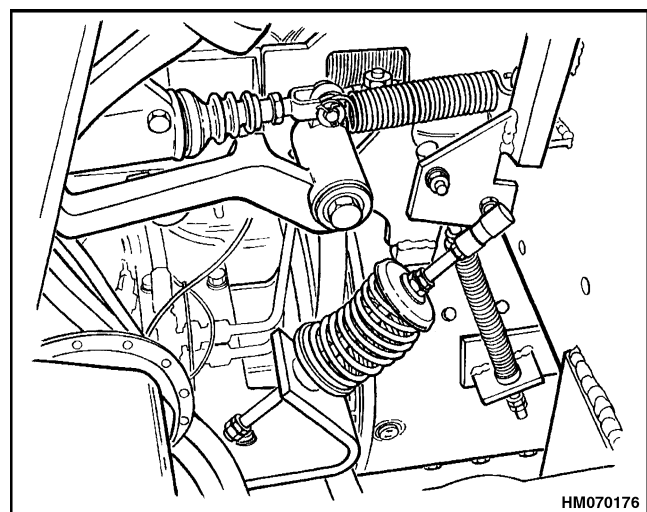
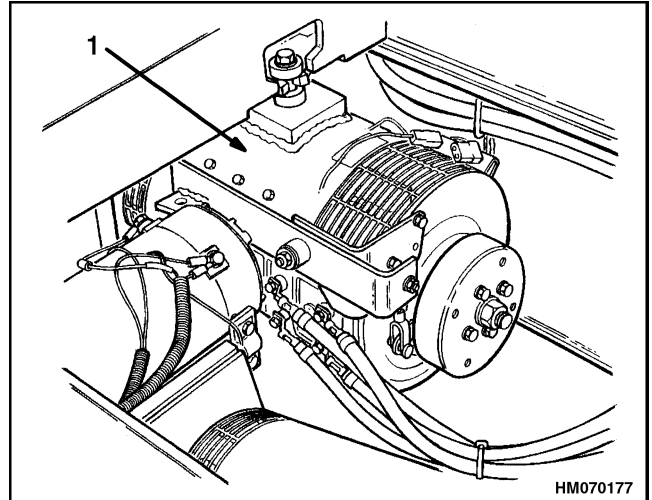

Figure 2. Seat Brake Linkage, ERC070-120HD/HG (A839) Models

6. Remove adjustment spring. First, loosen two jam nuts at bottom of rod. Then, turn top jam nut up rod so spring will be locked in compressed position. Disconnect spring and rod assembly from seat lever and lift assembly from bracket on speed reducer housing.
7. Remove clamp for main hoist hose from top of speed reducer housing. Remove clamp for tilt hoses from top of housing.

Traction Motor, Speed Reducer, and Differential

1. Mark traction motor electrical leads for identification and remove leads from motor. See Figure 3.
2. Continue the removal procedure as described in Motor, Speed Reducer, and Differential, Remove.



NOTE: TRACTION MOTOR USED ON ERC070-120HD/HG (A839) MODELS SHOWN.

1. TRACTION MOTOR

Figure 3. Disconnect Traction Motor

Motor, Speed Reducer, and Differential, Remove

STEP 1.

Put sling around traction motor for support. Attach sling to lifting device. Remove capscrew that fastens motor to lift truck frame. Slowly lower motor to ground.

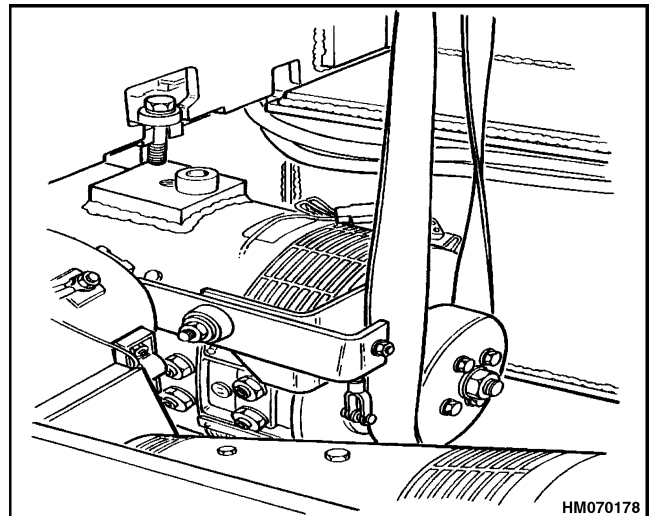

NOTE: Traction motor used on ERC070-120HD/HG (A839) models shown.

CAUTION

Make sure that the steer wheels do not come off the wheel blocks while raising the front of the lift truck.

STEP 2.

Attach lifting chains through two access holes in front of cowl plate and carefully raise lift truck off wheel blocks at drive wheels. Use an overhead crane with enough capacity to raise lift truck.

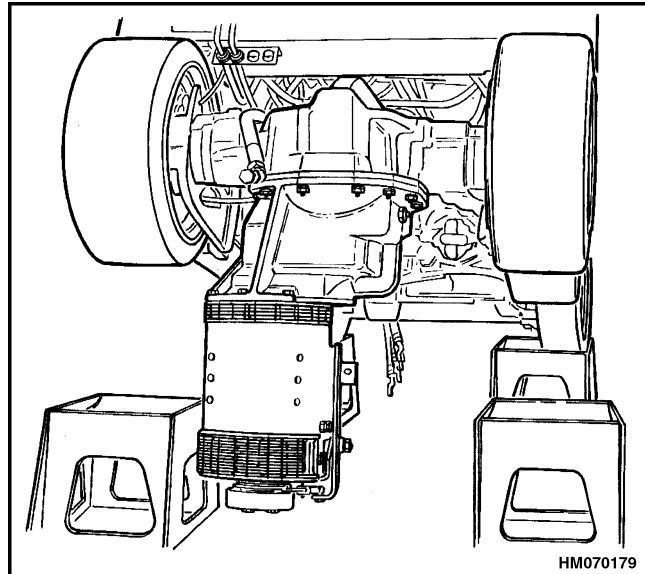

NOTE: Traction motor used on ERC070-120HD/HG (A839) models shown.

STEP 3.

Raise lift truck until traction motor is suspended vertically under drive axle. Use sling around traction motor. Pull sling toward front of lift truck as lift truck drive wheels are lowered onto wheel blocks.

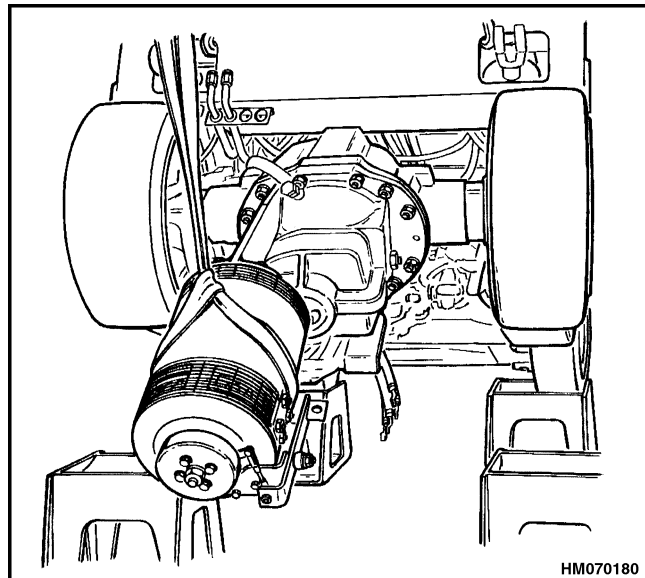

NOTE: Traction motor used on ERC070-120HD/HG (A839) models shown.

STEP 4.

Pivot traction motor upward to approximately 15 degrees above horizontal. Put blocks under differential for support.

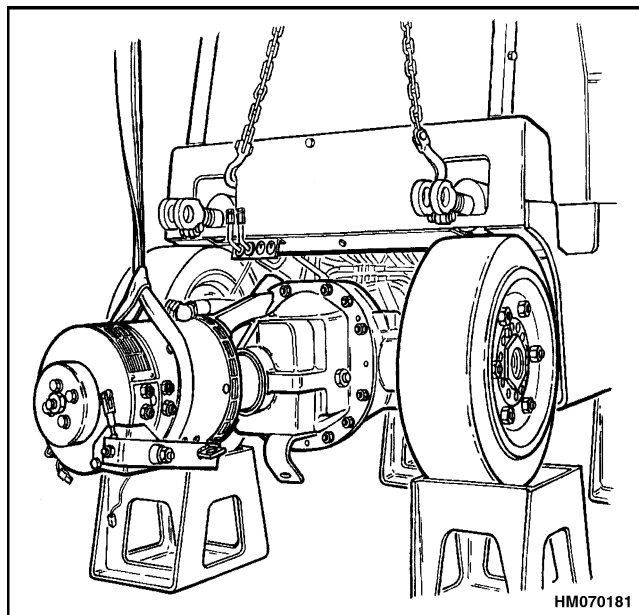

NOTE: Traction motor used on ERC070-120HD/HG (A839) models shown.

STEP 5.

Keep sling and lifting device attached to motor for support and remove all capscrews that fasten motor to speed reducer.

Carefully remove traction motor from speed reducer and put motor on a suitable work or storage area. See the section **DC Motor Maintenance** 620 YRM 294 for lift truck models ERC070-120HD/HG (A839) or **AC Motor Repair** 620 YRM 1098 for lift truck models ERC35-55HG (ERC70-120HH) (B839/C839) for repair procedures for traction motor if required.

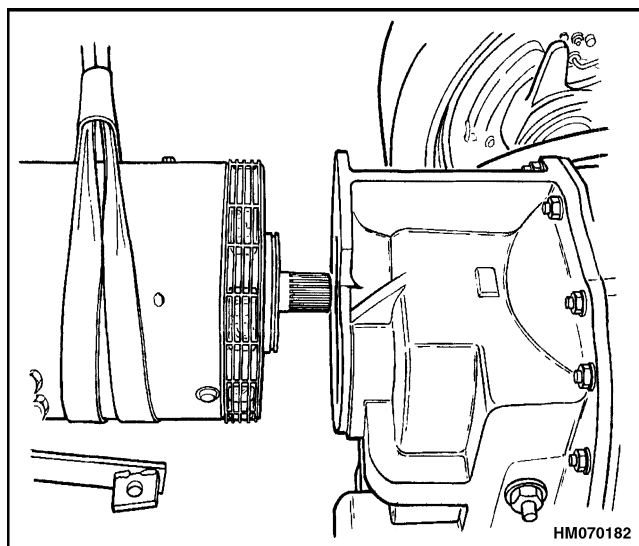

NOTE: Traction motor used on ERC070-120HD/HG (A839) models shown.

STEP 6.

Support speed reducer with sling and lifting device. Remove capscrews and nuts that fasten speed reducer to differential housing and carefully pull speed reducer from differential.

Put speed reducer on a suitable work or storage area.

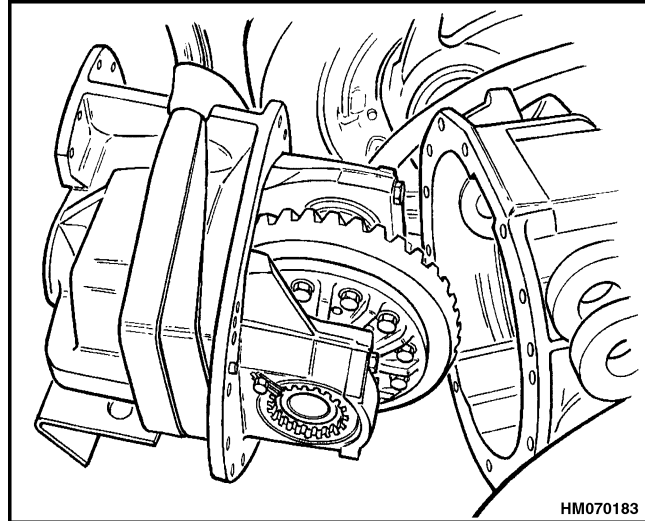
**DISASSEMBLE****Speed Reducer**

1. Remove access plate from top of speed reducer. Remove bearing cap from end of pinion shaft by hand or use a small pry bar. See Figure 4.
2. Disassemble only the parts of speed reducer and differential that must be repaired.

NOTE: If the ring gear and pinion are not to be replaced, but parts of the differential must be replaced, check contact pattern before disassembly. The pattern and the gear clearance are used as references for assembly. See the Assemble section of this manual for the procedures.

3. Loosen or remove thrust screw for differential ring gear. Remove bearing caps, adjusting nuts, bearing cups, and differential assembly. Make sure you do not change parts from right and left sides of differential.
4. Use a sharp punch to raise lock detent from slot in pinion shaft. Raise lock detent as carefully as possible so there is minimum damage to threads on pinion shaft when special lock nut is removed.
5. Use a soft piece of metal (copper or aluminum) to prevent speed reducer gear from turning when special lock nut is removed. Use soft piece of metal between speed reducer gears or between speed reducer gear and housing. Remove special lock nut. This special lock nut is tightened to 430 N•m (320 lbf ft). Discard special lock nut. Use a new special lock nut for assembly.
6. Remove special washer with key tab. Use a brass hammer to remove pinion from speed reducer case. The speed reducer gear and outer spacer will slide from pinion shaft as it is removed from speed reducer case. Make a note of shim arrangement between bearing and outer spacer.
7. Remove speed reducer gear and outer spacer from speed reducer case.
8. Remove inner spacer from pinion shaft. Use a press to remove bearing cone from pinion. Make a note of shim arrangement between bearing cone and pinion.
9. Use a press or a puller to remove bearing cones from speed reducer case.

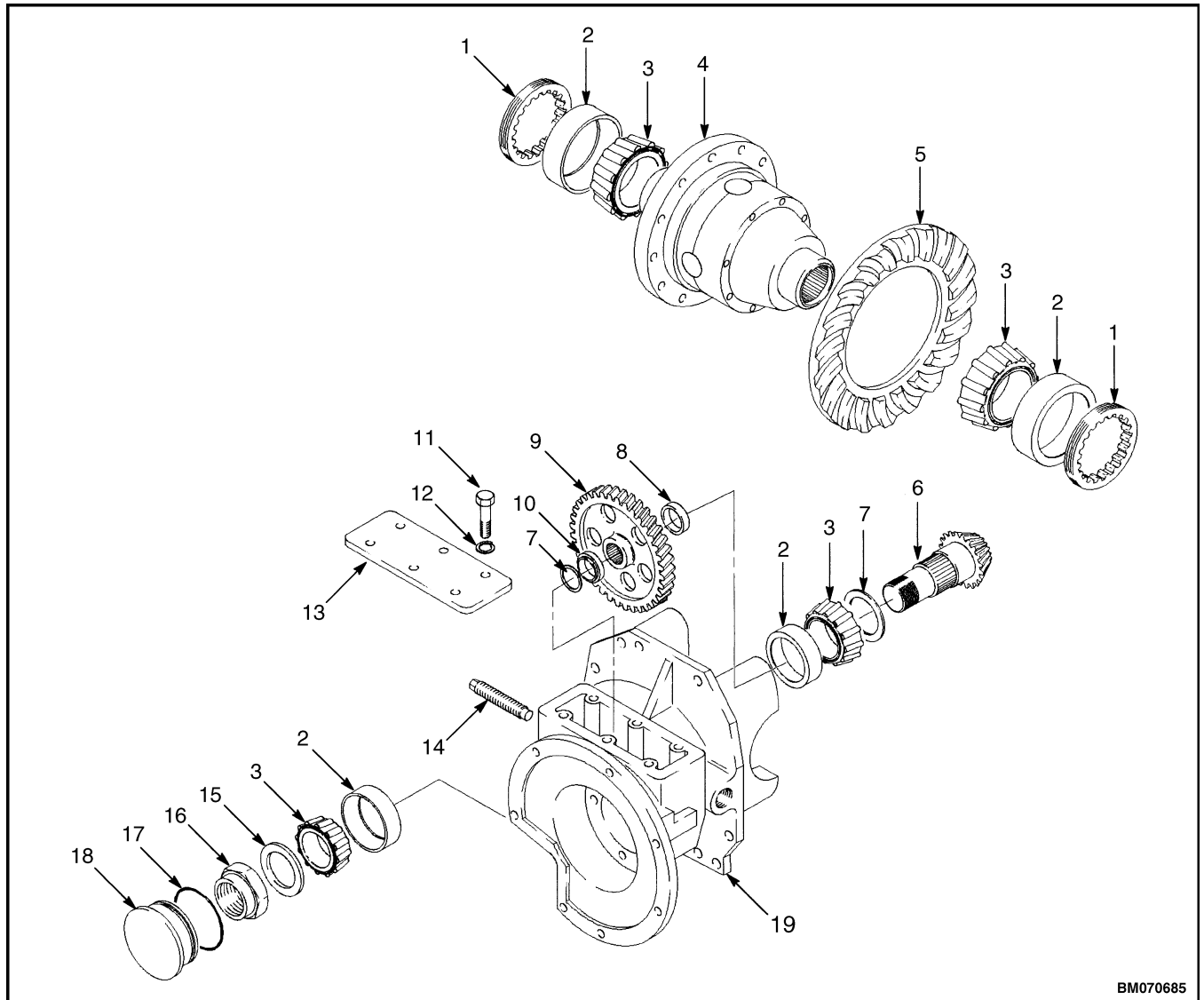

BM070685

- | | | |
|--------------------------|-----------------------|------------------------|
| 1. ADJUSTING NUT | 8. SPACER (INNER) | 15. SPECIAL WASHER |
| 2. BEARING CUP | 9. SPEED REDUCER GEAR | 16. SPECIAL LOCK NUT |
| 3. BEARING CONE | 10. SPACER (OUTER) | 17. O-RING |
| 4. DIFFERENTIAL ASSEMBLY | 11. CAPSCREW | 18. BEARING CUP |
| 5. RING GEAR | 12. WASHER | 19. SPEED REDUCER CASE |
| 6. PINION SHAFT | 13. ACCESS PLATE | |
| 7. SHIM | 14. THRUST SCREW | |

Figure 4. Speed Reducer Assembly

Differential

1. Remove ring gear from differential assembly. Remove twelve bolts and special hardened washers. **Do not use a press or a hammer to remove the ring gear.** Heat differential in hot water, 82 to 100°C (180 to 212°F), to loosen ring gear.

WARNING

Hot parts. Wear protective clothing and gloves to prevent burns.

2. Disassemble the differential. Remove eight cap screws and washers and separate differential case. Remove cross, spider gears, and axle gears.

- Remove bearing retainer for input gear to speed reducer. Remove four capscrews and washers. Remove bearing retainer, gear, and bearings. Make a note of shim arrangement between retainer and speed reducer case. Use a puller to remove inner bearing cup from speed reducer case.

CLEAN



WARNING

Always wear safety glasses.

Cleaning solvents may be flammable and toxic and can cause severe skin irritation. When using cleaning solvents, always comply with the solvent manufacturer's recommended safety precautions.

Compressed air can move particles so that they cause injury to the user or to other personnel. Wear protective goggles or a face shield to prevent injury to the eyes.

Clean parts of drive axle with solvent. Dry parts with compressed air.

INSPECT

- Check pinion and ring gear for wear. Inspect spider gears and axle gears for worn teeth. Inspect cross for wear where gears turn. The cross and holes for the cross in the differential case must fit tightly.
- Inspect bearings and seals for defects.
- The mount brackets must turn freely on the axle housings. The splines for the axle shafts must not be damaged.

ASSEMBLE

Speed Reducer

Input Gear, Install

- Install bearing cup in end of bore in speed reducer case. Use a press to install bearing cones on each end of input gear. Install input gear and bearings into speed reducer case. Install outer bearing cup.
- Install shims and bearing retainer. Install four M8 × 1.25 × 25 capscrews and washers. Tighten capscrews to 19 N•m (14 lbf ft). Check bearing clearance. Add or remove shims to adjust for

zero bearing clearance. The input gear must turn smoothly with a maximum rotation torque of 0.133 N•m (1.2 lbf in).

New Pinion, Install

If the ring gear or pinion is worn or damaged, they must be replaced as a set. See Figure 5. The ring gear and pinion must have the same reference numbers. When the pinion bearings are replaced or the ring gear and pinion are replaced, the shim arrangement must be adjusted for the new parts. Service persons must often make more than one adjustment before the clearances are correct. The speed reducer must be disassembled for shim adjustment and then assembled again for checks. The adjustments are correct when the gear clearance and contact pattern between the pinion and ring gear are correct and the preload on the pinion bearings is correct.

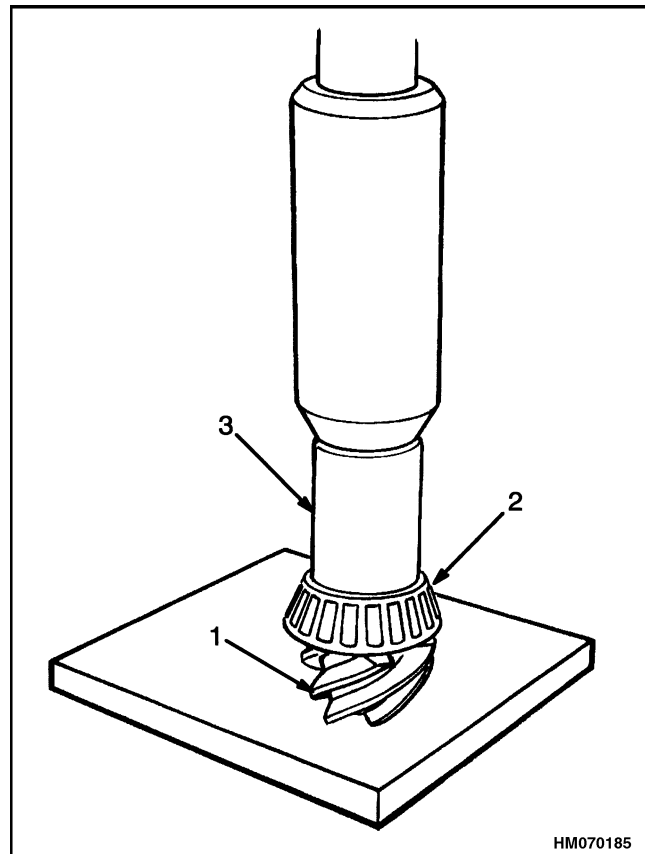

HM070185

- PINION
- BEARING CONE
- PRESS TOOL

Figure 5. Use Press to Install Pinion Parts

CAUTION

Do not lock the special nut on the pinion shaft until the adjustments of the pinion are complete. The lock on the special nut will damage the threads on the pinion shaft if the special nut must be removed several times for adjustments. If the threads are damaged on the pinion shaft, the pinion and ring gear must be replaced.

The dimension on the end of the pinion is the variation from the test dimension. See Figure 6. The test dimension is the distance from the center of the ring gear to the bearing shoulder behind the pinion gear. Shims must be added between the pinion and the bearing to adjust for manufacturing tolerances. See Table 1.

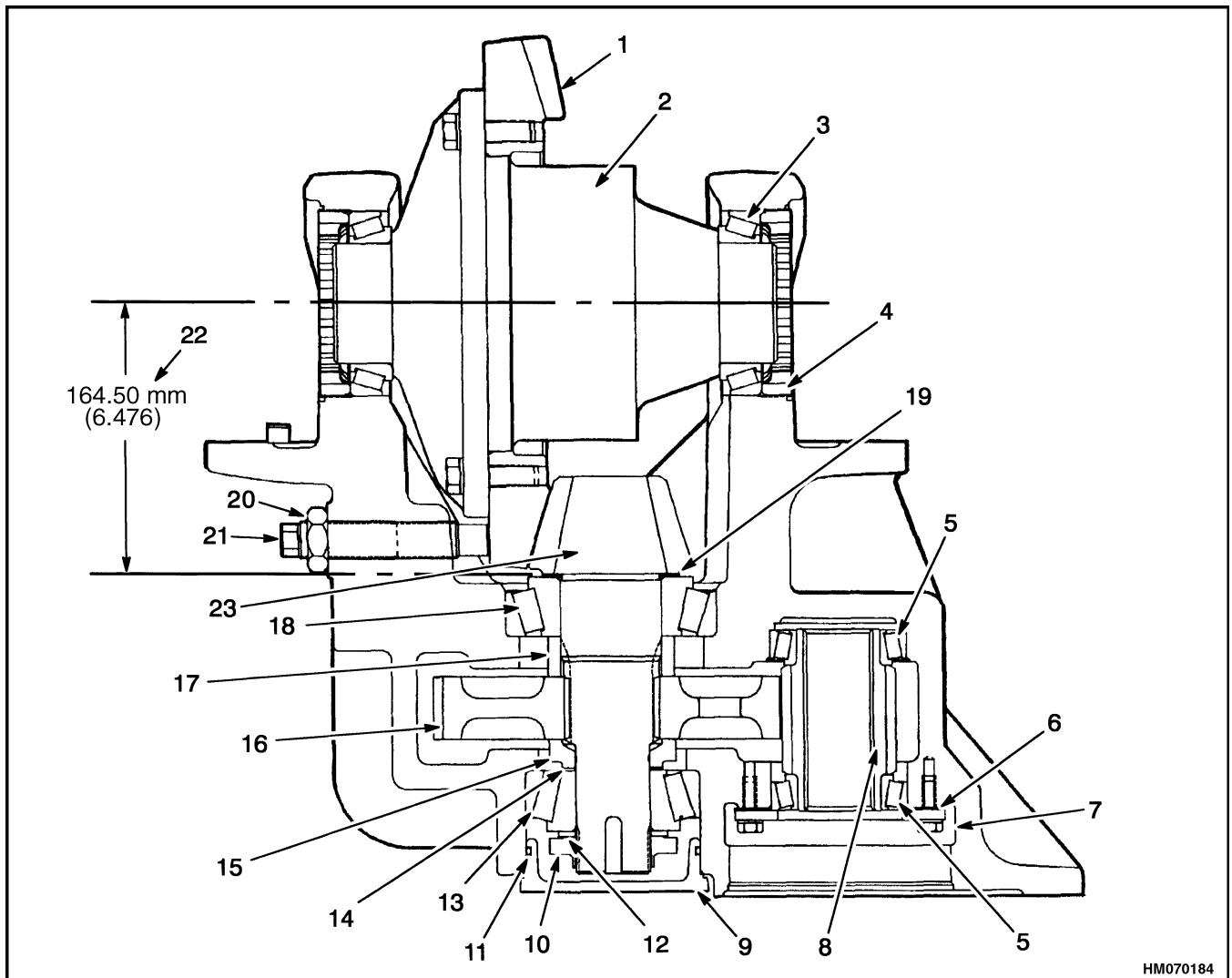

- | | | | |
|--------------------------|-----------------|--------------------|---------------------|
| 1. RING GEAR | 6. SHIM | 12. WASHER (KEYED) | 18. BEARING |
| 2. DIFFERENTIAL ASSEMBLY | 7. RETAINER | 13. BEARING | 19. SHIMS |
| 3. BEARING | 8. GEAR | 14. SHIMS | 20. JAM NUT |
| 4. ADJUSTER NUT | 9. HUB CAP | 15. SPACER | 21. THRUST SCREW |
| 5. BEARING (2) | 10. SPECIAL NUT | 16. GEAR | 22. TEST DIMENSION* |
| | 11. O-RING | 17. SPACER | 23. PINION |

*THE TEST DIMENSION IS 164.50 mm (6.476 in.) PLUS OR MINUS THE VARIATION SHOWN ON THE END OF THE PINION. THE ADJUSTMENT MUST BE ± 0.025 mm (0.001 in.) OF THE ACTUAL DISTANCE.

Figure 6. Differential and Speed Reducer Assembly



Suggest:

For more complete manuals. Please go to the home page.

<https://www.ebooklibonline.com>

If the above button click is invalid. Please download this document first, and then click the above link to download the complete manual.

Thank you so much for reading

Table 1. Pinion Assembly Shims Adjustment

Examples	1	2	3	4
Number of OLD PINION –Number on (NEW PINION)	+0.31 –(+0.26)	+0.31 –(–0.26)	+0.26 –(+0.31)	+0.26 –(+0.31)
Shims to be REMOVED FROM or ADDED TO the old set.	0.05 mm REMOVE	0.57 mm REMOVE	0.05 mm ADD	0.57 mm ADD

Look at the number on the pinion that was removed. Subtract the variation number that is on the pinion. The remainder is the amount of shim thickness that must be removed from the shim set on the pinion that was removed. (In examples 3 and 4, you can see that shims must be added. Examples 1 and 2 show that shims must be subtracted from the original shim set. Use this shim set as a reference. The final adjustment of the shims is set according to the contact pattern on the teeth of the ring gear. See Ring and Pinion Tooth Contact Adjustment.

NOTE: The pinion and ring gear are made in sets. Both the ring gear and pinion have marks with the same number. If the original pinion is not available and the + or – dimension is not known, adjust the pinion to the test dimension shown in Figure 6. The test dimension is 164.50 mm (6.476 in.). Use shims between the pinion and the bearing to obtain the test dimension + or –0.025 mm (0.001 in.).

1. If the bearing cups for the pinion were removed, install them in speed reducer case.
2. Install shims on pinion and use a press to install bearing cone. Install spacer on pinion shaft. See Figure 7.
3. Put speed reducer gear and spacer in speed reducer case. Install pinion in speed reducer case and slide speed reducer gear and spacer on pinion shaft when it is installed.
4. Install shims on pinion shaft that control preload on pinion bearings. Install bearing cone, washer with key tab, and special lock nut. Use a soft piece of metal (copper or aluminum) as a wedge to prevent speed reducer gear from turning. Tighten special lock nut to 430 N•m (320 lbf ft). Do not lock special nut to 430 N•m (320 lbf ft). Do not lock special nut at this time.
5. Check rotating torque of pinion and speed reducer assembly. The correct rotating torque is 1.13 to

2.26 N•m (10 to 20 lbf in). Lightly hit outside of housing to adjust bearings in their seats. Add or remove shims between spacer and bearing cone to adjust bearing preload.

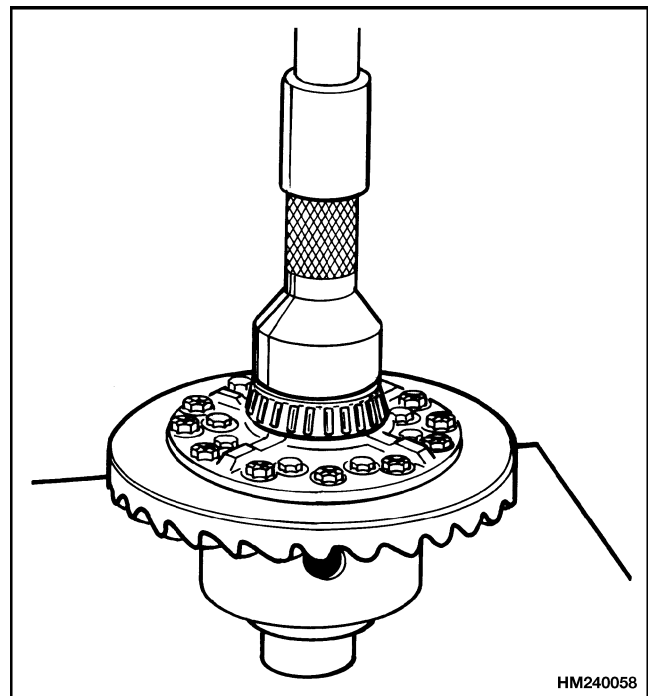

Figure 7. Bearing Cones Installation

Differential

1. Lubricate and install an axle gear and thrust washer in speed reducer case. Put spider gears and thrust washer on cross and put spider gear assembly into speed reducer case. Install second axle gear and thrust washer. Put two halves of speed reducer case together. Apply Loctite to threads of capscrews and install twelve capscrews and washers. Tighten capscrews to 130 to 170 N•m (96 to 125 lbf ft).
2. If ring gear was removed from speed reducer case, put ring gear into hot water [82 to 100°C (180 to 212°F)] for approximately 10 minutes. Remove ring gear from the liquid and put it into position on speed reducer case. Do not use a press or a hammer to install ring gear. Install 12 bolts and chamfered washers, position washers with chamfer facing away from the capscrew head. Tighten bolts to 142 N•m (105 lbf ft). Make sure ring gear is in correct position against flange of speed reducer case.



WARNING

Hot parts. Wear protective clothing and gloves to prevent burns.

3. Use a press to install bearing cones on each side of speed reducer case.
4. Install differential assembly, bearing cups, adjusting nuts, and bearing caps in speed reducer housing. Make sure parts are installed in their original positions. Tighten capscrews for bearing caps to 225 N•m (166 lbf ft). See Figure 8.
5. Tighten adjusting nuts to 14 N•m (10 lbf ft) to remove clearance between adjusting nuts and bearings. Make sure there is clearance between ring gear and pinion. Loosen one adjusting nut until there is zero clearance between bearings and adjusting nut. Tighten adjusting nut three notches more than zero clearance to put a preload on bearings.
6. Check clearance between ring gear and pinion. The ring gear and pinion must have a clearance of 0.254 to 0.330 mm (0.010 to 0.013 in.). Use adjusting nuts to move ring gear toward or away

from engagement with pinion gear. Loosen one adjusting nut the same amount as the other adjusting nut is tightened to adjust clearance between ring gear and pinion. See Figure 9.

7. Check pattern on teeth of ring gear. Apply an indicator color (Prussian blue or yellow) to teeth. Use a pry bar between ring gear and housing to prevent ring gear from turning freely. Turn pinion shaft. Compare pattern on ring gear teeth with patterns shown in Table 2. Adjust gear clearances as necessary.

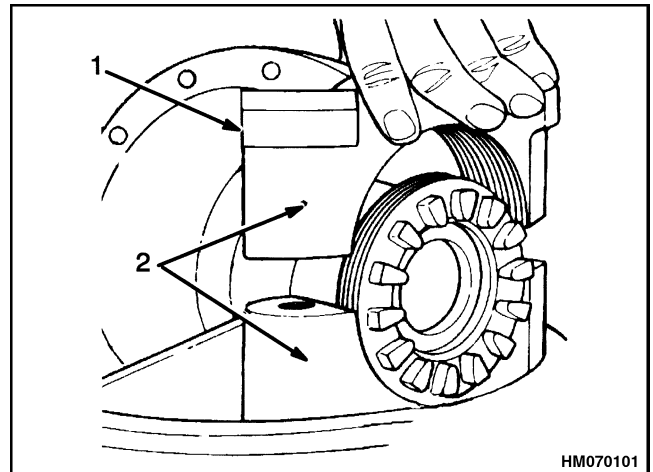

1. BEARING CAP
2. MATCHMARKS

Figure 8. Bearing Caps Installation

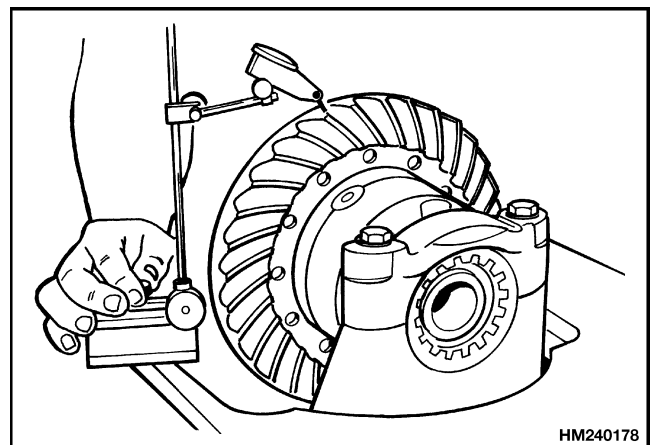

Figure 9. Clearance Check Between Ring Gear and Pinion

<https://www.ebooklibonline.com>

Hello dear friend!

Thank you very much for reading.

Enter the link into your browser.

The full manual is available for immediate download.

<https://www.ebooklibonline.com>