

Document Title: General precautions	Function Group: 191	Information Type: Service Information	Date: 2014/3/31
Profile: CEX, EW55B [GB]			

General precautions



WARNING

For safety, observe the following rules.

Safety precautions

- When carrying out any operation or maintenance, have trained and experienced personnel carry out the work.
- When carrying out any operation or maintenance, carefully read the Operation and Maintenance Manual. Read all the precautions given on the decals which are fixed to the machine.

Safety device

- Make sure that all guards and covers are mounted in their proper position. Repair or replace if damaged.
- Pay attention to the method of using any safety locking device or safety belt.

Safety clothes and helmet

- Wear the specified work clothes in the correct manner.
- Use the specified protective gear (helmet, safety glasses, safety shoes, mask, gloves). Guard against injury from flying pieces of metal or debris, wear goggles, gloves and helmet. Always have a trained and experienced welder carry out any welding work. When carrying out welding work, always wear welding gloves, apron, glasses, cap and other clothes suitable for welding work.

Prepare for emergencies

- Know where fire extinguishers are located and how to use them.
- Keep a first aid kit and an eye wash kit near the work area.
- Keep emergency numbers for doctors, ambulance service, hospital, and fire department near your telephone.

Handle fluids safely—avoid fires

- Handle fuel with care. It is highly flammable.
- Do not refuel the machine while smoking or when near open flame or sparks. Always stop the engine before refuelling machine. Fill the fuel tank outdoors.
- Store flammable fluids away from fire hazards. Do not incinerate or puncture pressurized containers.

Dispose of fluids properly

- Improperly disposing of fluids can harm the environment and ecology. Before draining any fluids, find out the proper way to dispose of waste from your local environmental agency.
- Catch draining fuel, oil, or other fluids in suitable containers. Do not use food or beverage containers that may mislead someone into drinking from them. Wipe up spills at once.
- Do not pour oil into the ground, down a drain, or into a stream, pond, or lake. Observe relevant environmental protection regulations when disposing of oil, fuel, coolant, brake fluid, filters, batteries, and other harmful waste.

Working in contaminated environment

- Used cab and engine air filters from machines which operate in environments containing asbestos or other dangerous dust must be placed in the tight-fitting bag, before they are deposited in a designated place.

- The machine must be equipped for work within an environment which is contaminated or constitutes a health hazard before the work is initiated. Besides, special local regulations apply for such operations and for servicing a machine which has been used in such environment.

Document Title: Cautions during operation	Function Group: 191	Information Type: Service Information	Date: 2014/3/31
Profile: CEX, EW55B [GB]			

Cautions during operation

Service cooling system safely

- At operating temperature, the engine coolant is hot and under pressure. The radiator and all lines to the heaters and engine contain hot coolant. Any contact can cause severe burns.
- Hot coolant can cause personal injury.
- Check the coolant level only after the engine has been stopped and the radiator pressure cap is cool enough to remove with your bare hand.
- Remove the radiator pressure cap slowly to release pressure.
- Cooling system additive contains alkali that can cause personal injury. Avoid contact with the skin, eyes and mouth.
- Allow cooling system components to cool before draining.

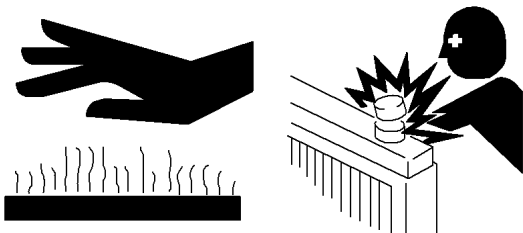

V1003920

Figure 1

Hot coolant can burn you

Avoid high-pressure fluids

- Escaping fluid under pressure can penetrate the skin causing serious injury.
- Avoid the hazard by releasing pressure before disconnecting hydraulic or other lines. Tighten all connections before applying pressure.
- Fluid leaks under pressure may not be visible. Use a piece of cardboard or wood to find leaks but do not use your bare hand. Protect hands and body from high pressure fluids.
- Be careful not to break, twist or damage the high pressure pipes. A jet spray of high pressure oil can cause electrical fires.

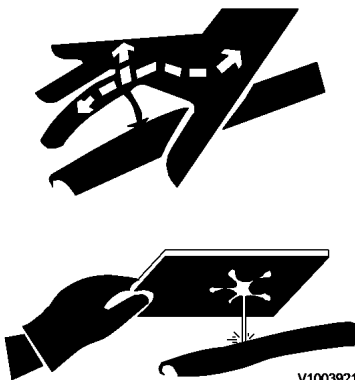

V1003921

Figure 2

Avoid high pressure fluids

Handling of heavy objects

- When raising heavy components, use a hoist or crane.
- Ensure that wire ropes, chains and hooks are free from damage.
- Always use lifting equipment which has ample capacity.
Install the lifting equipment at the correct places.
- Use a hoist or crane and operate slowly to prevent the component hitting any other part.
- When disassembling or assembling, support the machine with blocks, jacks or stands before starting work.
Never use concrete blocks for supports. They can collapse under even light loads.
- Before starting work, lower the blade, ripper, bucket or any other work equipment to the ground.
- Do not work under the equipment when the equipment is not sufficiently supported.

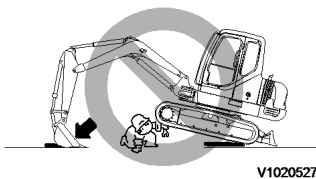
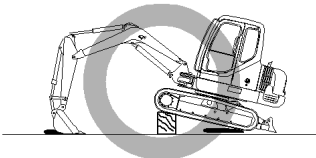

Figure 3
Support the equipment safely

Electrical system

- When welding on the machine or working on the electrical system, ALWAYS turn the master switch STOP position and remove the lead from the battery negative (-) terminal.
- The battery master switch is installed inside the tool box located on the right side of machine.
- When removing components, be careful not to break or damage the wiring.
Damaged wiring can cause electrical fires.
- When working on the battery, wear goggles or safety glasses.
- Sulphuric acid in battery electrolyte is poisonous.
It is strong enough to burn skin and eat holes in clothing and cause blindness if splashed into the eyes.
If you spill acid on your clothes or skin, immediately flush with large quantities of clean water, then get medical attention.
- If splashed into the eyes, flush with water and get medical attention immediately.
- Keep sparks, lighted matches, and open flame away from the top of battery. Battery (hydrogen) gas can explode.

<https://www.ebooklibonline.com>

Hello dear friend!

Thank you very much for reading.

Enter the link into your browser.

The full manual is available for immediate download.

<https://www.ebooklibonline.com>

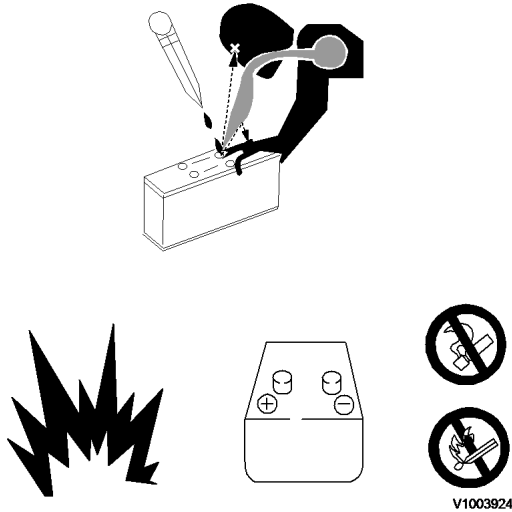

Figure 4
When working on the battery, pay attention

- Battery posts and cables touched by metal objects can short circuit and burn you.
- Keep tools away from posts, wires and terminals.
- Tighten the battery terminals to ensure good contact.
- When disassembling and assembling the battery, make sure that the battery terminals are correctly connected.

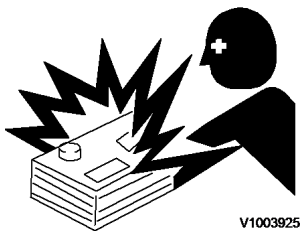

Figure 5
Battery posts and cables can burn you

- If water gets to the electrical system, abnormal operation or failure can result. Do not use water or steam on sensors, connectors and instruments in the cab.

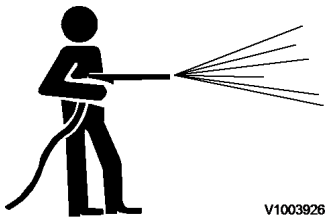

Figure 6
Do not use water or steam in the cab

Cautions during operation

- When removing covers which are under internal pressure or under pressure from a spring, always leave two screws in position on opposite sides. Slowly release the pressure, then slowly loosen the screws.

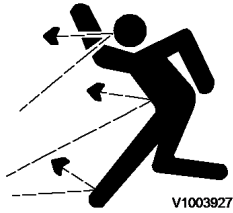

Figure 7

Be careful when opening the grease valve

- High pressure grease in the spring package of the undercarriage can explode and injure you. Be careful when opening the grease valve. Do not loosen the grease valve more than 1 turn until the pressure is released.
- When assembling or installing parts, always use the specified tightening torque.
- When installing protective parts such as guards, or parts which rotate at high speed, be particularly careful to check if they are installed correctly.
- Be sure that your clothes or hair do not contact any rotating components.



Figure 8

Do not contact rotating parts

- When aligning two holes, never insert your fingers or hand. Be careful not to get your fingers pinched in a hole, or between parts or tools.

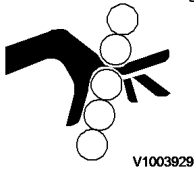

Figure 9

Be careful of your finger (1)



Figure 10

Be careful of your finger (2)

- Never touch rotating parts such as the fan blades or fan belt.



Figure 11

Never touch rotating parts

- Pay attention when removing or installing the tracks of track type machines. When removing the track pin, the track separates suddenly, so never let anyone stand at either end of the track. Always block both ends of the track to prevent any sudden uncontrolled movement.

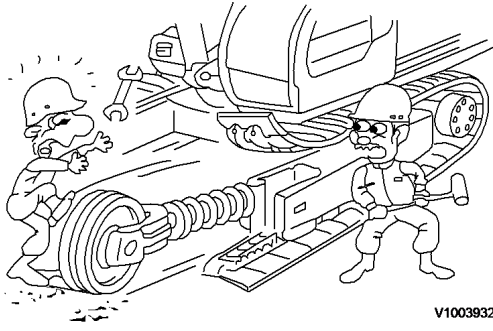

V1003832

Figure 12
Pay attention when removing or installing the tracks

Document Title: Preparations for work	Function Group: 191	Information Type: Service Information	Date: 2014/3/31
Profile: CEX, EW55B [GB]			

Preparations for work

Warn others of service work

- Unexpected machine movement can cause serious injury.
- Before performing any work on the machine, attach a "Do Not Operate" tag to the right control lever.
- When carrying out any operation with two or more workers, always agree on the operating procedure before starting.



Figure 1

Warn others when carrying out any operation

- Whether a "Do Not Operate" tag is attached or not, sound the travel alarm when the machine starts to move.
- Illuminate your work area adequately but safely. Use a portable safety light for working inside or under the machine. Make sure the bulb is enclosed by a wire cage. The hot filament of an accidentally broken bulb can ignite spilled fuel or oil.

Use tools properly

- Use a tool only for its designed application.
- Keep all tools in good condition and know the correct way to use them.
- Decide on a place in the repair workshop to keep tools and removed parts.
- Always keep the work area clean and make sure that there is no dirt or oil on the floor.
- Before adding oil or making any repairs, park the machine on hard, level ground and put blocks under the wheels or tracks to prevent the machine from moving.
- Before starting work, lower the blade, ripper, bucket or any other work equipment to the ground. If that is not possible, insert the safety pin or use blocks to prevent the work equipment from falling.

WARNING

Place the control lockout lever securely to "Locked" position to lock out the control hydraulics before starting the engine or leaving the operator's seat. Unless the control lockout lever is in the "Locked" position, control levers can be operated by careless touch, which could cause serious injury.

Safety locking system

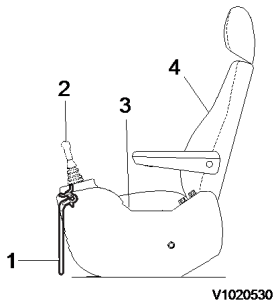

Figure 2
Safety locking system (1)

1. Safety bar
2. Control lever (left)
3. Left console instrument panel
4. Backrest

- Safety bar is in the operating position (A) is for working with the machine. When the safety bar is in this position the engine can not be started.
- When travel mode selector switch is in travel/work mode, traveling is possible in (A) position.
- When travel mode selector switch is in travel mode, traveling is possible in all positions. (A, B, C and D)

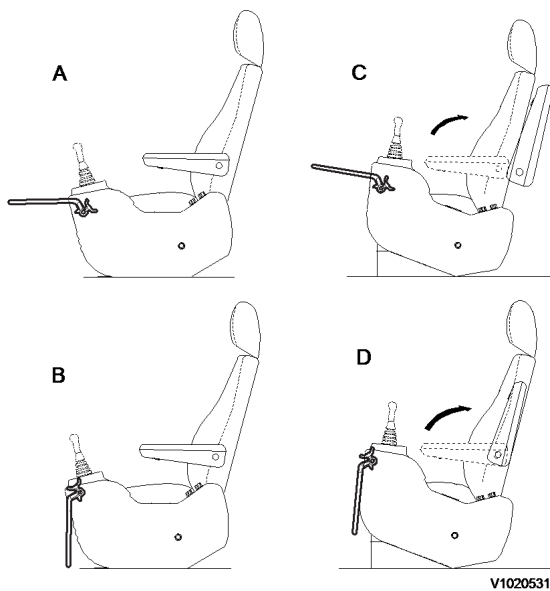

Figure 3
Safety locking system (2)

- A. Operating position (When the safety bar is in this position the engine can not be started)
- B. Locked position (When the safety bar is in this position the engine can be started)
- C. Tilted position
- D. Tilted and locked position

- This system is used for Locking out the attachment, slew and travelling. Place the safety bar located on the left console instrument panel in the "Locked" (B) and "Tilted" (C, D) position to lock out the hydraulic control levers. When the safety bar is in this position the engine can be started. Travelling is possible in (A) position. Tilting function is only for easy entrance on the seat.

Use handholds and steps

- Never jump on or off the machine.

- Remove all mud and oil from the steps of other places used to get on and off the machine.

Document Title: Move and operate machine safely	Function Group: 191	Information Type: Service Information	Date: 2014/3/31
Profile: CEX, EW55B [GB]			

Move and operate machine safely

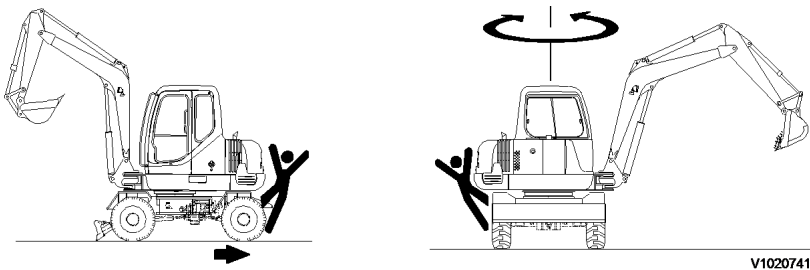

Figure 1

Before moving, slewing or operating the machine check that the area is clear.

- Only allow the operator on the machine. Keep all riders off.
Know the location of bystanders before moving, slewing or operating the machine.
- Always keep the travel alarm in working condition.
- Use a signal person when moving, slewing or operating the machine in a congested area.
- Before traveling check the traveling direction. Particularly, for reverse traveling, check that no person is in the area after slewing to the rear side. Use the travel alarm before traveling.

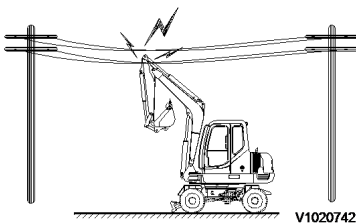

Figure 2

Don't contact electric power lines

- Serious injury or death can result from contact with electric power lines. Never move any part of the machine or load closer to the electric power line than the minimum established safe distance.
- Refer to the Operator's Manual for further details.

Document Title: Recommended lubricants	Function Group: 160	Information Type: Service Information	Date: 2014/3/31
Profile: CEX, EW55B [GB]			

Recommended lubricants

System	Oil grade	Recommended viscosity at varying ambient temperatures									
		°C	-30	-20	-10	0	+10	+20	+30	+40	+50
		°F	-22	-4	+14	+32	+50	+68	+86	+104	+122
Engine	1) Engine oil		SAE 5W/30			SAE 10W/30			*SAE 15W/40		
			SAE 30			SAE 40					
Track reduction gearbox	Gear oil (With EP additive) API GL4 or GL5		*SAE90			SAE140					
Slew ring gear	Gear oil (With EP additive) API GL4 or GL5		*SAE90			SAE140					
Slew ring gear (Bath and Ball)	Grease		Multi purpose EP-grease NLGI 2								
Hydraulic system	Hydraulic oil (Anti-wear hydraulic oil with high viscosity index 160 or more)		ISO VG32 HV			ISO VG46 HV			ISO VG68 HV		
	Bio oil (Based on synthetic ester)		Bio oil VG32			Bio oil VG46					
Pin and bushing	Grease		*ISO-L-XBCFB2								
Fuel tank	Diesel fuel		ASTM D975 No.1			*ASTM D975 No.2					
2) Cooling system	Coolant	Volvo genuine coolant should be used only. *(Water 50 %, antifreeze 50 %)									
	Volvo Coolant VCS	Volvo Coolant VCS should be used only. *(Water 50 %, antifreeze 50 %)									
Air conditioner system	Refrigerant	HFC R134a									
		°C	-30	-20	-10	0	+10	+20	+30	+40	+50
		°F	-22	-4	+14	+32	+50	+68	+86	+104	+122

NOTE!

1) Recommended engine oil grade (VDS-3 or Global DHD-1 + VDS-2 or ACEA-E5 + VDS-2 or API CH-4 + VDS-2)

NOTE!

*: Installed at factory.

- ASTM: American Society of Testing and Material
- SAE: Society of Automotive Engineers

- ISO: International Standardization Organization
- API: American Petroleum Institute

Refill capacities (approximate)

Kind of fluid (Reservoir)	Capacity, liters (gal)	
	Specified	Refill
Engine oil (engine oil pan)	10.1 (2.7)	9.7 (2.5)
Hydraulic oil (hydraulic oil tank)	130 (34)	90 (23.8)
Engine oil (slew gearbox)	1.1 (0.3)	
Gear oil (Transfer gearbox)	3.8 (1.0)	
Diesel fuel (fuel tank)	100 (26.4)	
Grease (slew ring gear)	6.0 (1.6)	
Axle housing (front, rear)	Front housing : 3.9 (1), hub : 0.8 (0.2) Rear housing, hub : 5.2(1.4)	
Coolant (cooling system)	13.3 (3.5)	

- Specified capacity: Total amount of oil including oil for components and oil in piping.
- Refill capacity: Amount of oil needed to refill reservoir during periodic inspection and maintenance.

NOTE!

When fuel sulphur content is less than 0.3%, change engine oil every 250 hours. Change oil according to the following table if fuel sulphur content is above 0.3%.

Fuel sulphur content and change interval

Fuel sulphur content	Change interval of oil in engine oil pan
0.3% to 0.5%	1/2 of regular interval
Above 0.5%	1/4 of regular interval

NOTE!

When starting the engine in an ambient temperature of lower than 0 °C, be sure to use engine oil of SAE 10W, SAE 10W–30 and SAE 15W–40, even though the ambient temperature goes up to 10 °C more or less in the day time.

NOTE!

The fuel should at least meet the legal requirement, and national and international standards for marketed fuels, for example: EN590 (with nationally adapted temperature requirements), ASTM D975 No 1D and 2D, JIS KK 2204.

NOTE!

Use API classification CF or CG as engine oil, and if API classification CD, reduce the engine oil change interval to half.

2) Cooling system

- The cooling system is either filled with Volvo Coolant VCS or Volvo Coolant. To avoid damage to the engine, it is very important to continue to use the same coolant, when filling or changing, as the system is filled with.
- Do not mix different coolants or corrosion protection as this may result in engine damages.
- To distinguish the coolant from each, the cooling system is filled with Volvo Coolant VCS if
 - it is yellow.
 - a decal with the text “Volvo Coolant VCS” is put by the filling point.



V1043894

The cooling system is filled with Volvo Coolant if

- it is green.

- the decal mentioned above, is not by the filling point.

- Machine serial number installed at factory:

- Volvo Coolant: ~ 30629

- Volvo Coolant VCS: 30630 ~

NOTE!

See the Operator's manual for detailed information on Volvo Coolant VCS.

Document Title: Periodic maintenance	Function Group: 173	Information Type: Service Information	Date: 2014/3/31
Profile: CEX, EW55B [GB]			

Periodic maintenance

Recommended periodic maintenance must always be performed as stipulated to keep the machine in excellent operating condition to ensure safe operation.

Improper lubrication, maintenance and operation of the machine can be dangerous and cause injury or death to you or other persons on the jobsite.

NOTE!

Refer to the operator's manual for detailed information on periodic maintenance.

Document Title: Coolant, checking anti-freeze resistance	Function Group: 173	Information Type: Service Information	Date: 2014/3/31
Profile: CEX, EW55B [GB]			

Coolant, checking anti-freeze resistance

Op nbr 261-002

[88890105 Refractometer](#)



WARNING

Open the expansion tank cap slowly and carefully. The cooling system operates at high pressure and hot coolant may rush out and cause severe burns.

1. Check the freezing protection with 88890105 Refractometer.
Open the cover on the refractometer and place a few drops of the coolant on the glass surface. Close the cover and read off the value against strong light source.
Read off the value on the ethylene scale. The coolant should be taken from the filling point on the expansion tank.

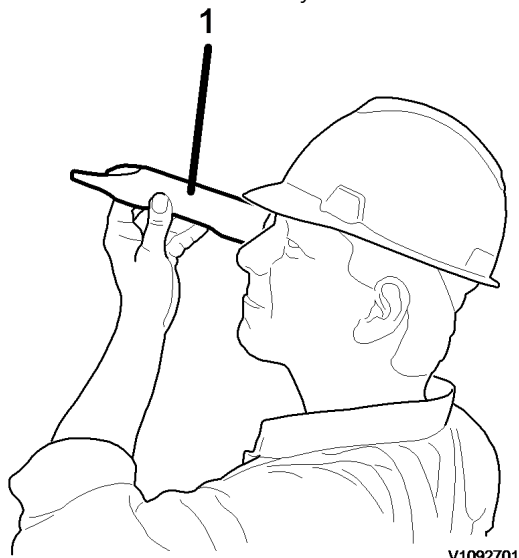

V1092701

Figure 1

2. The machine is delivered with a coolant mixture for optimal cooling and corrosion characteristics.
That is why the same coolant mixture shall be filled, regardless of ambient temperature conditions. See [160 Coolant](#) and [160 Coolant with freezing and corrosion protection](#).

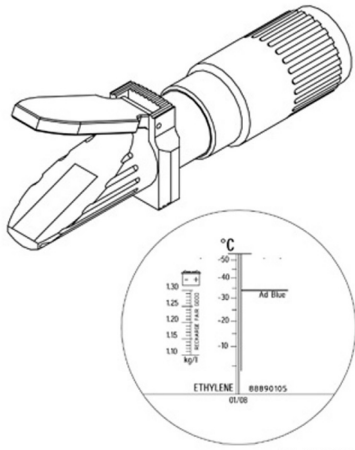

V1075419

Figure 2

NOTE!

Volvo Construction Equipment concentrated coolant with anti-freeze must not be mixed with other brands of anti-freeze or additives as this type of mixture could have negative effects.

Document Title: Measuring condition	Function Group:	Information Type: Service Information	Date: 2014/3/31
Profile: CEX, EW55B [GB]			

Measuring condition

The purpose of this chapter is to explain how to evaluate the various performances of Volvo Construction Equipment hydraulic excavators.

The tolerances shown are for new machines.

For a machine already in use, certain allowance is permitted according to field conditions.

Unless otherwise specified, measurements should be performed under the following conditions:

- Engine speed: high rpm
- Hydraulic oil temperature: 50 ± 5 °C (122 ± 9 °F)
- Site: firm, level ground
- Bucket load: empty



Suggest:

For more complete manuals. Please go to the home page.

<https://www.ebooklibonline.com>

If the above button click is invalid. Please download this document first, and then click the above link to download the complete manual.

Thank you so much for reading

Document Title: Cylinder speed	Function Group:	Information Type: Service Information	Date: 2014/3/31
Profile: CEX, EW55B [GB]			

Cylinder speed

Preparation

Boom cylinder

- Arm cylinder is fully retracted.
- Bucket cylinder is fully extended.
- Measure the time for the boom from bucket position contacting ground surface to maximum boom raising position.

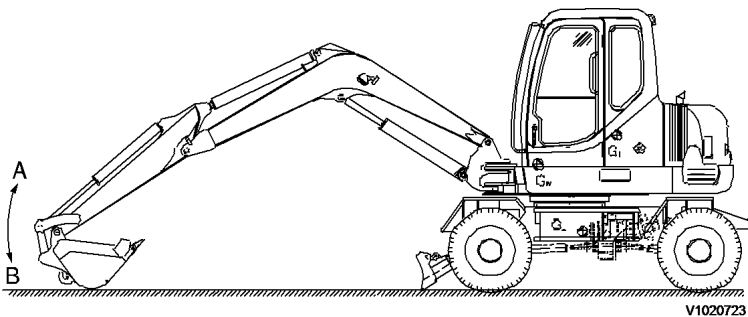

Figure 1
Measuring condition, boom cylinder

- B → A : Raise
- A → B : Lower

Arm cylinder

- Bucket cylinder is fully extended.

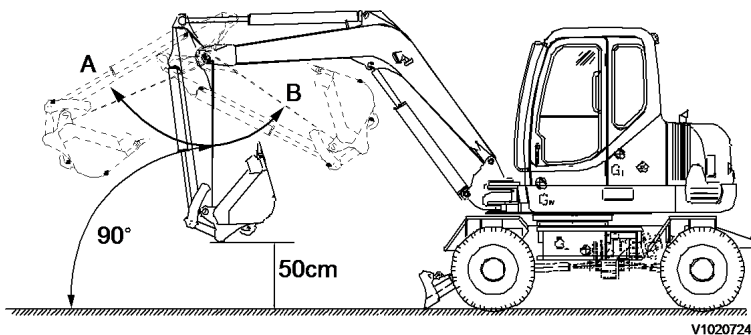
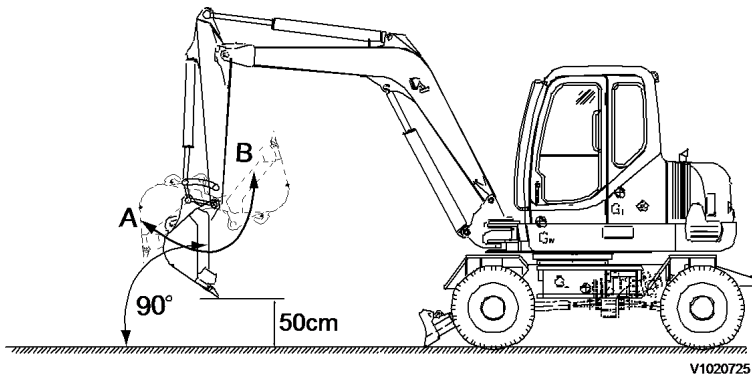

Figure 2
Measuring condition, arm cylinder

- B → A : Roll out
- A → B : Roll in

Bucket cylinder



V1020725

Figure 3
Measuring condition, bucket cylinder

- B → A : Roll out
- A → B : Roll in

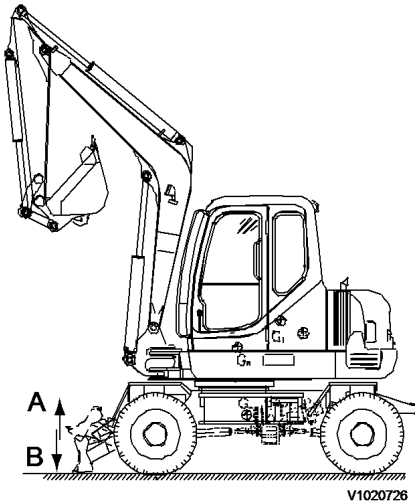

V1020726

Figure 4
Measuring condition, blade cylinder

- B → A : Raise
- A → B : Lower

Blade cylinder

Boom slew cylinder (option)

- Arm cylinder is fully retracted.
- Bucket cylinder are fully extended.
- Measure the time, for the boom to slew from the fully opposite position to the left or right side.

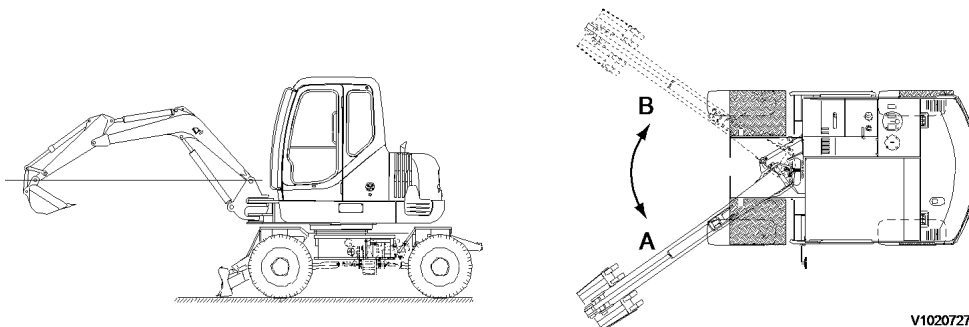

V1020727

<https://www.ebooklibonline.com>

Hello dear friend!

Thank you very much for reading.

Enter the link into your browser.

The full manual is available for immediate download.

<https://www.ebooklibonline.com>