

Document Title: Product plates	Function Group: 000	Information Type: Service Information	Date: 2015/6/3 0
Profile: EXC, EC330C L, EC360C L, EC360C NL, EC460C L, EC360C HR [GB]			

Product plates

When ordering spare parts, and in all telephone enquiries or correspondence the model designation and the Product Identification Number (PIN) must always be quoted.

Product plate

The product plate on the machine shows the manufacturer's name and address, model designation, PIN, machine weight, engine output, production year and year of delivery. There is also room for the CE mark. The plate is positioned under the boom on the superstructure frame.

Engine

The engine product plate contains type designation and part and serial numbers and is positioned on the engine inside the rear engine cover on the right side of the machine.

Attachment quick coupler

The attachment quick coupler nameplate is attached on the outside of the attachment quick coupler. (shows part number and weight)

Bucket

The bucket nameplate is attached on the top of the bucket. (shows the bucket model order No, Serial number, bucket part number, rated capacity, weight, cutting width, tooth part number and adapted part number)

Cab

The nameplate is attached on the inside of the cab and indicates the product number, serial number, model type, and weight.

Document Title: Component locations	Function Group: 000	Information Type: Service Information	Date: 2015/6/3 0
Profile: EXC, EC460C L [GB]			

Component locations

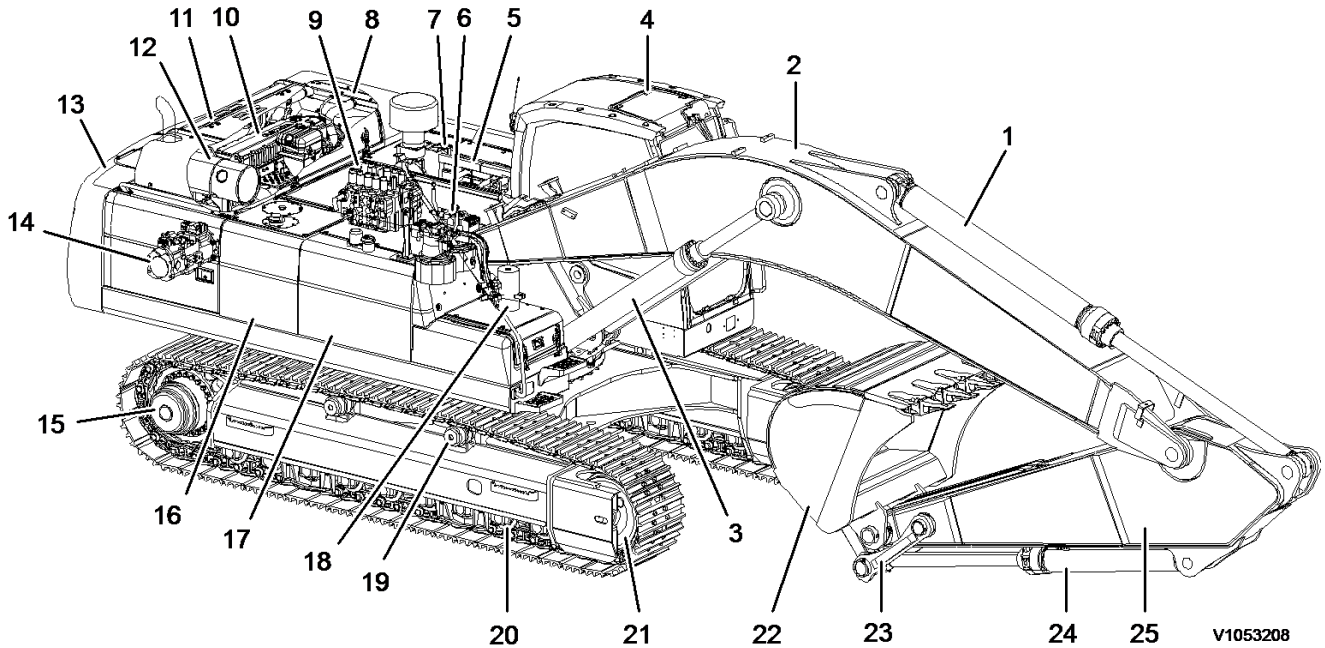

Figure 1
Component position

1 Dipper arm cylinder	14 Main pump
2 Boom	15 Track motor and gearbox
3 Boom cylinder	16 Hydraulic tank
4 Operator cab	17 Fuel tank
5 Oil cooler	18 Center passage
6 Slew motor and gearbox	19 Top roller
7 Air cleaner	20 Bottom roller
8 Radiator and charge air cooler	21 Idler
9 Main control valve	22 Bucket
10 Engine	23 Link
11 Rear hood	24 Bucket cylinder
12 Muffler	25 Dipper arm
13 Counterweight	

Document Title: Measurement conversion tables	Function Group: 030	Information Type: Service Information	Date: 2015/6/3 0
Profile: EXC, EC460C L [GB]EXC, EC460C L [GB]			

Measurement conversion tables

Length

Unit	cm	m	km	in	ft	yd	mile
cm	1	0.01	0.00001	0.3937	0.03281	0.01094	0.000006
m	100	1	0.001	39.37	3.2808	1.0936	0.00062
km	100000	1000	1	39370.7	3280.8	1093.6	0.62137
in	2.54	0.0254	0.000025	1	0.08333	0.02777	0.000015
ft	30.48	0.3048	0.000304	12	1	0.3333	0.000189
yd	91.44	0.9144	0.000914	36	3	1	0.000568
mile	160930	1609.3	1.6093	63360	5280	1760	1

1 mm = 0.1 cm, 1 mm = 0.001 m

Area

Unit	cm2	m2	km2	a	ft2	yd2	in2
cm2	1	0.0001	-	0.000001	0.001076	0.000012	0.155000
m2	10000	1	0.000001	0.01	10.764	1.1958	1550.000
km2	-	1000000	1	10000	1076400	1195800	-
a	0.01	100	0.0001	1	1076.4	119.58	-
ft2	-	0.092903	-	0.000929	1	0.1111	144.000
yd2	-	0.83613	-	0.008361	9	1	1296.00
in2	6.4516	0.000645	-	-	0.006943	0.000771	1

1 ha = 100 a, 1 mile² = 259 ha = 2.59 km²

Volume

Unit	cm3 = cc	m3	Liter	in3	ft3	yd3
cm3 = m liter	1	0.000001	0.001	0.061024	0.000035	0.000001
m3	1000000	1	1000	61024	35.315	1.30796
Liter	1000	0.001	1	61.024	0.035315	0.001308
in3	16.387	0.000016	0.01638	1	0.000578	0.000021
ft3	28316.8	0.028317	28.317	1728	1	0.03704
yd3	764529.8	0.76453	764.53	46656	27	1

1 gal(US) = 3785.41 cm³ = 231 in³ = 0.83267 gal(US)

Weight

Unit	g	kg	t	oz	lb
g	1	0.001	0.000001	0.03527	0.0022
kg	1000	1	0.001	35.273	2.20459

t	1000000	1000	1	35273	2204.59
oz	28.3495	0.02835	0.000028	1	0.0625
lb	453.592	0.45359	0.000454	16	1
1 tonne(metric) = 1.1023 ton(US) = 0.9842 ton(UK)					

Pressure

Unit	kgf/cm2	bar	Pa=N/m2	kPa	lbf/in2	lbf/ft2
kgf/cm2	1	0.98067	98066.5	98.0665	14.2233	2048.16
bar	1.01972	1	100000	100	14.5037	2088.6
Pa=N/m2	0.00001	0.001	1	0.001	0.00015	0.02086
kPa	0.01020	0.01	1000	1	0.14504	20.886
lbf/in2	0.07032	0.0689	6894.76	6.89476	1	144
lbf/ft2	0.00047	0.00047	47.88028	0.04788	0.00694	1
1 kgf/cm2 = 735.56 Torr(mmHg) = 0.96784 atm						

Approximate conversions

SI	Conversion	Non-SI	Conversion	SI
Unit	Factor	Unit	Factor	Unit
Torque				
newton meter (N·m)	x 10.2	= kgf·cm	x 0.8664	= (lbf·in)
newton meter (N·m)	x 0.74	= lb·ft	x 1.36	= N·m
newton meter (N·m)	x 0.102	= kgf·m	x 7.22	= (lbf·ft)
Pressure (Pa = N/m²)				
kilopascal (kPa)	x 4.0	= in. H ₂ O	x 0.249	= kPa
kilopascal (kPa)	x 0.30	= in. Hg	x 3.38	= kPa
kilopascal (kPa)	x 0.145	= psi	x 6.89	= kPa
(bar)	x 14.5	= psi	x 0.069	= (bar)
(kgf/cm ²)	x 14.22	= psi	x 0.070	= (kgf/cm ²)
(newton/mm ²)	x 145.04	= psi	x 0.069	= (bar)
megapascal (MPa)	x 145	= psi	x 0.00689	= MPa
Power (W = J/s)				
kilowatt (kW)	x 1.36	= PS (cv)	x 0.736	= kW
kilowatt (kW)	x 1.34	= HP	x 0.746	= kW
kilowatt (kW)	x 0.948	= Btu/s	x 1.055	= kW
watt (W)	x 0.74	= ft·lb/s	x 1.36	= W
Energy (J = N·m)				
kilojoule (kJ)	x 0.948	= Btu	x 1.055	= kJ
joule (J)	x 0.239	= calorie	x 4.19	= J
Velocity and Acceleration				
meter per sec ² (m/s ²)	x 3.28	= ft/s ²	x 0.305	= m/s ²
meter per sec (m/s)	x 3.28	= ft/s	x 0.305	= m/s
kilometer per hour (km/h)	x 0.62	= mph	x 1.61	= km/h
Horse power/torque				
BHP x 5252 rpm = TQ (lb·ft)			TQ x rpm 5252 = B.H.P.	
Temperature				
°C = (°F - 32) / 1.8		°F = (°C x 1.8) + 32		
Flow Rate				

<https://www.ebooklibonline.com>

Hello dear friend!

Thank you very much for reading.

Enter the link into your browser.

The full manual is available for immediate download.

<https://www.ebooklibonline.com>

liter/min (dm³/min)

x 0.264

= US gal/min x 3.785

= liter/min

Note: () non-si unit

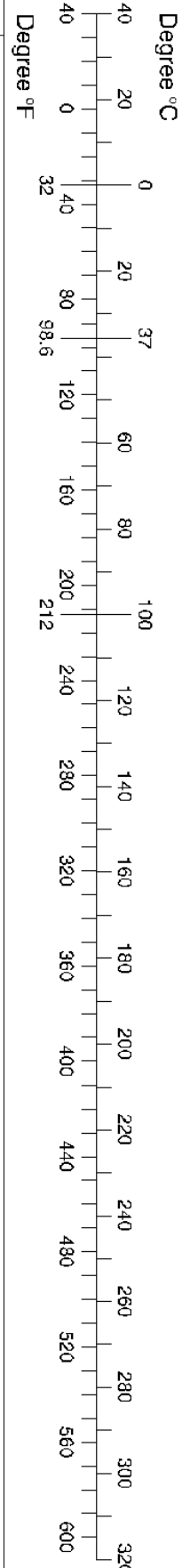

Document Title: Removable counterweight cylinder, specifications	Function Group: 030	Information Type: Service Information	Date: 2015/6/3 0
Profile: EXC, EC460C L [GB]			

Removable counterweight cylinder, specifications

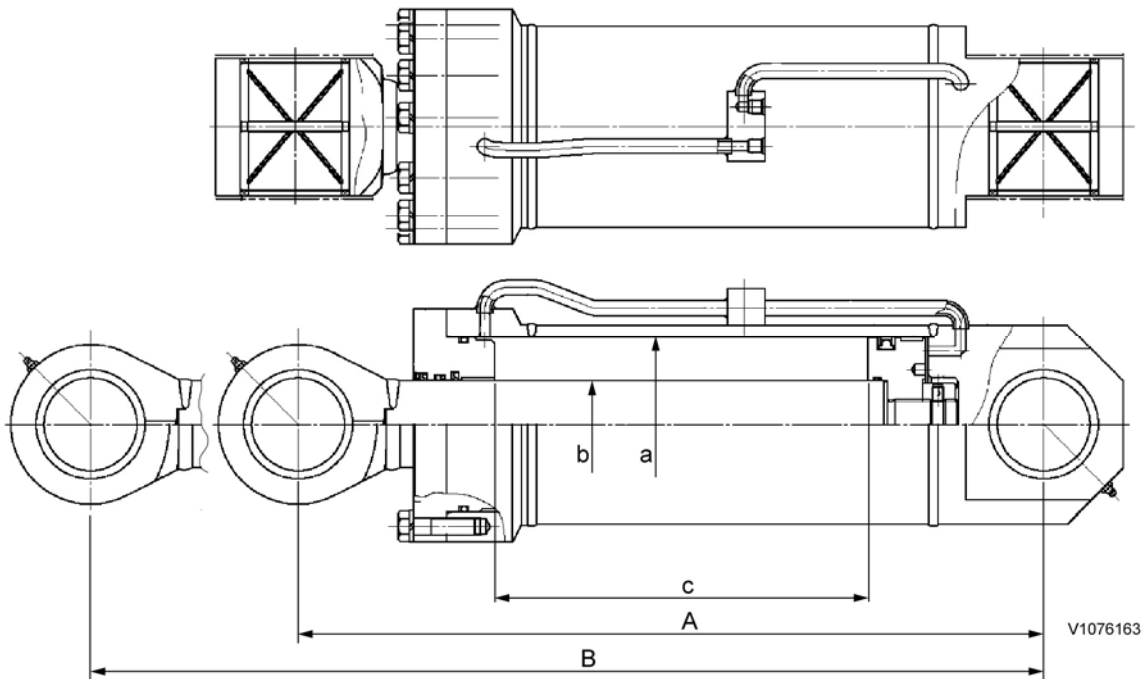

Figure 1
Removal counterweight cylinder



Item	Unit	Specifications
Removal cylinder	Quantity	EA 1
	Bore (a) × rod (b) × stroke (c)	mm (inch) φ160 × φ80 × 3421.5 (φ6.30 × φ3.15 × 134.7)
Center to center distance of pins	Full retracted (A)	6832 (269)
	Full extended (B)	1025 (40.4)
Cushion	EA	–
Operating pressure		31.4 MPa (320 kgf cm ²) (4552 psi) (313.8 bar)
Weight		170 kg (374.8 lbs)

Document Title: Standard tightening torques	Function Group: 030	Information Type: Service Information	Date: 2015/6/3 0
Profile: EXC, EC460C L [GB]			

Standard tightening torques

The following charts give the standard tightening torques of screws and nuts. Exceptions are given in each sections of "disassembly and assembly".

Tightening torque (meter)

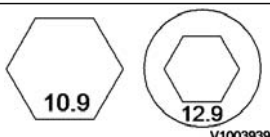
Classification		4.8T			8.8T			10.9T, 12.9T		
Screw type										
Screw size		Tightening torque			Tightening torque			Tightening torque		
mm	inch	N m	kgf m	lbf ft	N m	kgf m	lbf ft	N m	kgf m	lbf ft
M 4	0.15	1.96 ±0.19	0.2 ±0.02	1.4 ±0.1	-	-	-	3.92 ±0.39	0.4 ±0.04	2.9 ±0.3
M 5	0.19	2.94 ±0.29	0.3 ±0.03	2.2 ±0.2	5.88 ±0.59	0.6 ±0.06	4.3 ±0.4	7.84 ±0.78	0.8 ±0.08	5.8 ±0.6
M 6	0.23	4.90 ±0.49	0.5 ±0.05	3.6 ±0.4	9.8 ±0.98	1.0 ±0.10	7.2 ±0.7	13.72 ±1.37	1.4 ±0.14	10.1 ±1
M 8	0.31	11.76 ±1.17	1.2 ±0.12	8.7 ±0.9	23.541 ±2.35	2.4 ±0.24	17.3 ±1.7	32.36 ±2.94	3.3 ±0.3	23.8 ±2.2
M 10	0.39	22.55 ±2.25	2.3 ±0.23	16.6 ±1.7	48.05 ±4.9	4.9 ±0.5	35.4 ±3.6	63.74 ±6.86	6.5 ±0.7	46.9 ±5.1
M 12	0.46	39.22 ±3.92	4.0 ±0.4	29 ±3	85.32 ±8.83	8.7 ±0.9	62.8 ±6.5	110.81 ±10.78	11.3 ±1.1	81.6 ±7.9
M 14	0.55	62.7 ±5.88	6.4 ±0.6	46 ±4	140.24 ±13.73	14.3 ±1.4	103.2 ±10.1	175.53 ±17.65	17.9 ±1.8	129.2 ±13
M 16	0.62	93.16 ±8.82	9.5 ±0.9	69 ±6	219.67 ±21.57	22.4 ±2.2	161.7 ±15.9	261.83 ±26.47	26.7 ±2.7	192.8 ±19.5
M 18	0.71	132.3 ±13.72	13.5 ±1.4	97 ±10	290.28 ±29.42	29.6 ±3.0	213.7 ±21.7	372.65 ±37.26	38.0 ±3.8	274.4 ±27.4
M 20	0.78	182.40 ±18.63	18.6 ±1.9	134 ±14	430.51 ±43.14	43.9 ±4.4	317.0 ±31.8	511.90 ±50.99	52.2 ±5.2	376.9 ±37.5
M 22	0.87	242.22 ±24.51	24.7 ±2.5	178 ±18	579.57 ±57.85	59.1 ±5.9	426.7 ±42.6	680.58 ±67.66	69.4 ±6.9	501.1 ±49.8
M 24	0.94	314.79 ±31.38	32.1 ±3.2	232 ±23	740.40 ±73.54	75.5 ±7.5	545.1 ±54.2	884.56 ±88.25	90.2 ±9.0	651.2 ±65
M 30	1.17	613.80 ±61.78	62.6 ±6.3	452 ±45	-	-	-	1726.95 ±172.59	176.1 ±17.6	1271.4 ±127.1
M 36	1.40	1061.08 ±105.91	108.2 ±10.8	781 ±78	-	-	-	2984.16 ±298.12	304.3 ±30.4	2197 ±219.5
M 42	1.65	1684.78 ±168.67	171.8 ±17.2	1240 ±124	-	-	-	4738.57 ±473.66	483.2 ±48.3	3488.7 ±348.7
M 45	1.77	2072.15 ±206.92	211.3 ±21.1	1525 ±152	-	-	-	5828.09 ±582.51	594.3 ±59.4	4290.9 ±428.9

Tightening torque (inch)

Classification		4.8T			8.8T			10.9T, 12.9T		
Screw size		Tightening torque			Tightening torque			Tightening torque		
mm	inch	N m	kgf m	lbf ft	N m	kgf m	lbf ft	N m	kgf m	lbf ft
1/4	6.35	9.80 ±0.98	0.6 ±0.06	4.3 ±0.4	23.53 ±2.35	1.0 ±0.1	7.2 ±0.7	16.67 ±1.96	1.7 ±0.2	12.2 ±1.2
5/16	7.94	11.76 ±1.17	1.2 ±0.12	8.7 ±0.8	19.61 ±1.96	2.0 ±0.2	14.4 ±1.4	29.42 ±2.94	3.0 ±0.3	21.7 ±2.2
3/8	9.53	19.61 ±1.96	2.0 ±0.20	14.4 ±1.4	40.20 ±3.92	4.1 ±0.4	29.6 ±2.9	54.91 ±4.90	5.6 ±0.5	40 ±4
7/16	11.11	31.38 ±3.13	3.2 ±0.32	23 ±2	59.82 ±5.88	6.1 ±0.6	44.0 ±4.3	87.27 ±8.82	8.9 ±0.9	64 ±6
1/2	12.70	46.09 ±4.60	4.7 ±0.47	34 ±3	100.02 ±9.80	10.2 ±1.0	73.6 ±7.2	131.40 ±12.74	13.4 ±1.3	97 ±10
9/16	14.29	66.68 ±6.66	6.8 ±0.68	50 ±5	140.23 ±13.72	14.3 ±1.4	103.2 ±10.1	186.32 ±18.63	19.0 ±1.9	137 ±14
5/8	15.88	91.20 ±9.12	9.3 ±0.93	67 ±7	200.05 ±19.61	20.4 ±2.0	147.3 ±14.4	255.95 ±25.49	26.1 ±2.6	190 ±19
3/4	19.05	156.90 ±15.69	16.0 ±1.60	115 ±15	-	-	-	442.28 ±44.12	45.1 ±4.5	325 ±33
7/8	22.22	250.07 ±25.00	25.5 ±2.55	185 ±19	-	-	-	702.15 ±70.60	71.6 ±7.2	520 ±52
1	25.40	372.65 ±37.26	38.0 ±3.80	275 ±27	-	-	-	1048.33 ±104.93	106.9 ±10.7	770 ±77
1 1/8	28.58	530.54 ±53.05	54.1 ±5.41	390 ±39	-	-	-	1492.57 ±149.06	152.2 ±15.2	1100 ±110
1 1/4	31.75	727.65 ±72.76	74.2 ±7.42	535 ±54	-	-	-	2048.61 ±204.95	208.9 ±20.9	1510 ±151
1 3/4	34.93	968.89 ±96.88	98.8 ±9.88	710 ±71	-	-	-	2724.29 ±272.62	277.8 ±27.8	2000 ±200
1 1/2	38.1	1257.21 ±125.72	128.2 ±12.82	925 ± 93	-	-	-	3537.26 ±354.02	360.7 ±36.1	2600 ±260

NOTE!

This torque table does not apply to screws with nylon packings or where nonferrous metal washers are to be used, or which require tightening to a different specified torque, or tightening procedure.

NOTE!

N m (Newton meter): 1 N m ≅ 0.1 kgf m

Tightening torque of split flange screws

Use these torques for split flange screws.

Tightening torque (split flange screws)

Thread diameter of screw (mm)	Width across flats (mm)	Tightening torque		
		N m	kgf m	lbf ft
10	14	65.7 ±6.8	6.7 ±0.7	48.4 ±5
12	17	112 ±9.8	11.5 ±1	83 ±8
16	22	279 ±29	28.5 ±3	206 ±20

Tightening torque for hydraulic plugs with O-ring

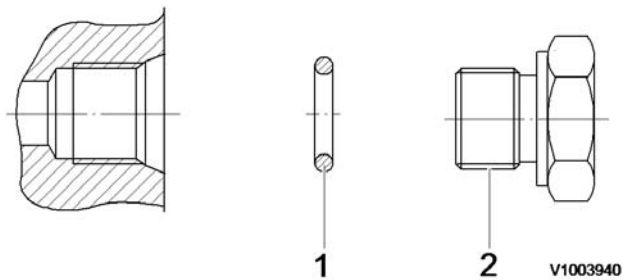

Figure 1
Hydraulic plugs with O-ring

1. O-ring
2. Plug

Pf thread

Tightening torque (hydraulic plugs)

Thread	Plug part No.	Tightening torque N m	Tightening torque kgf m	Tightening torque lbf ft
1/8	9415-11012	24.51 ±1.96	2.5 ±0.2	18 ±1.4
1/4	9415-11022	49.03 ±4.90	5.0 ±0.5	36 ±3.6
3/8	9415-11032	73.54 ±4.90	7.5 ±0.5	54 ±3.6
1/2	9415-11042	107.87 ±9.80	11.0 ±1.0	79 ±7
3/4	9415-11052	176.52 ±9.80	18.0 ±1.0	130 ±7
1	9415-11062	205.94 ±19.61	21.0 ±2.0	152 ±14

Tightening torque for swivel nut fitting with O-ring

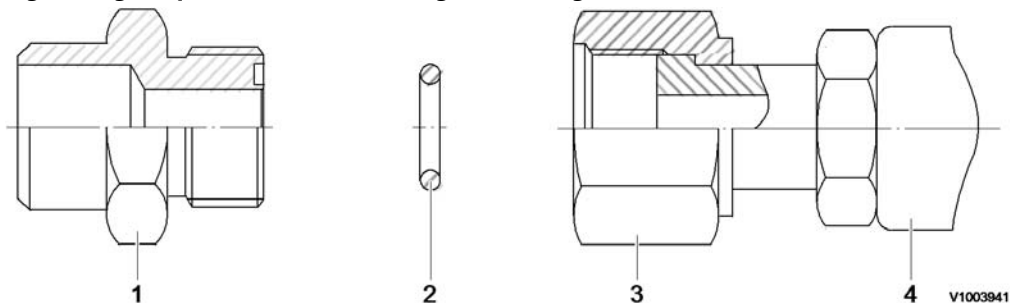

Figure 2
Swivel nut fitting with O-ring

1. Connector
2. O-ring
3. Swivel nut
4. Hose

Tightening torque for swivel nut fitting

Tube outer diameter (in)	Thread size (in)	Tightening torque, N m	Tightening torque, kgf m	Tightening torque, lbf ft
1/2	UN 13/16 – 16	93.16 ±9.31	9.5 ±0.95	69 ±7
3/4	UN 1 3/16 – 12	176.52 ±17.65	18 ±1.8	130 ±13
1	UN 1 7/16 – 12	205.94 ±20.59	21 ±2.1	152 ±15

Document Title: NET 8940-00200 Replace tool for the remote control valve joint	Function Group: 080	Information Type: Service Information	Date: 2015/6/3 0
Profile: EXC, EC460C L [GB]			

NET 8940-00200 Replace tool for the remote control valve joint

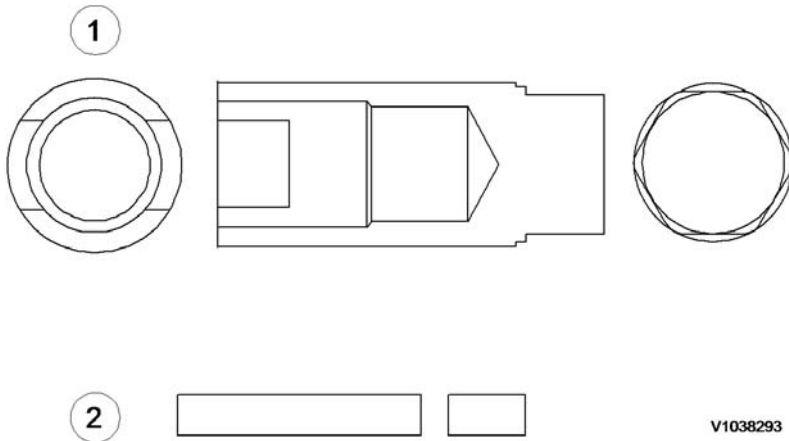

Figure 1
Replace tool for the remote control valve joint

Item	Quantity	Name	Remark
1	1	Socket	SAE 4130 (QT)
2	1	Stop plate	SAE 4130 (QT)

Document Title: E-tools, NET 8940-00330 Swing motor guide pin	Function Group: 080	Information Type: Service Information	Date: 2015/6/3 0
Profile: EXC, EC460C L [GB]			

E-tools, NET 8940-00330 Swing motor guide pin

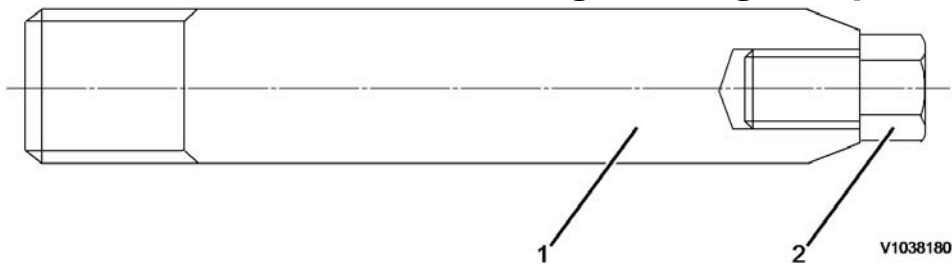

Figure 1
Swing motor guide pin

Item	Quantity	Name	Remark
1	2	Guide bar	SAE 4130 (25 ~ 35 HRC)
2	2	Screw	M8 × 16

Document Title: E-tools, NET 8940-00340 Replace tool for the swing ring gear	Function Group: 080	Information Type: Service Information	Date: 2015/6/3 0
Profile: EXC, EC460C L [GB]			

E-tools, NET 8940-00340 Replace tool for the swing ring gear

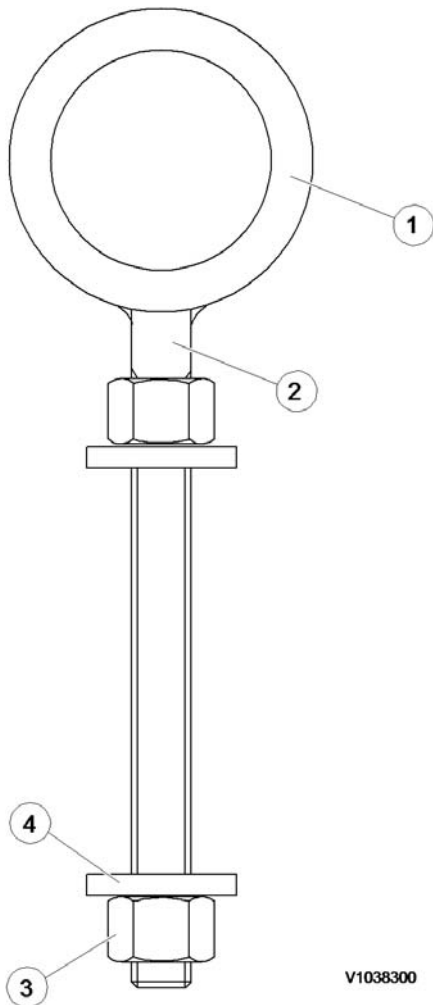
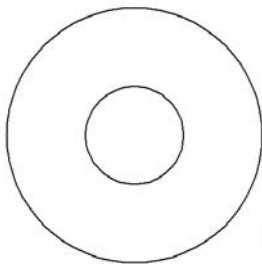
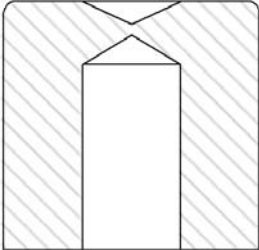

Figure 1
Replace tool for the slew ring gear

Item	Quantity	Name	Remark
1	2	Ring	SAE 1045 (QT)
2	2	Round bar φ18	SAE 1045 (QT)
3	4	Nut	M24
4	4	Washer ø25 × φ35 × 10 t	

Document Title: NET E 1678 Center support tool for the air conditioning compressor	Function Group: 080	Information Type: Service Information	Date: 2015/6/3 0
Profile: EXC, EC460C L [GB]			

NET E 1678 Center support tool for the air conditioning compressor



V1038301

Figure 1
Replace tool for the air conditioning compressor

Drawings of E-tools that can be manufactured in the workshop.

All dimensions on the drawings are given in mm unless otherwise indicated (1 mm = 0.03937 in).

Document Title: Service positions	Function Group: 091	Information Type: Service Information	Date: 2015/6/3 0
Profile: EXC, EC460C L [GB]			

Service positions

Park the machine on a horizontal and firm surface.

The suitable position is indicated in the description for the various service jobs.

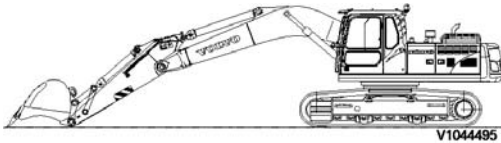

Figure 1
Service position A

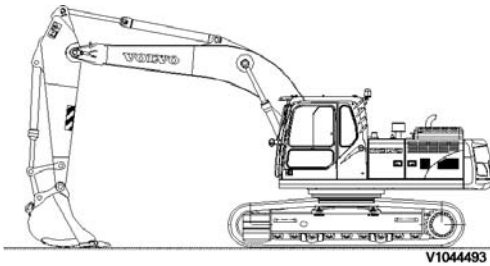

Figure 2
Service position B

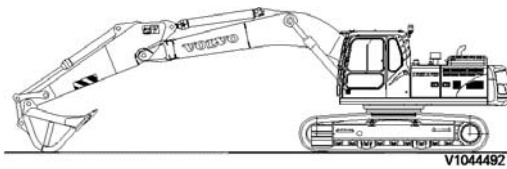

Figure 3
Service position C

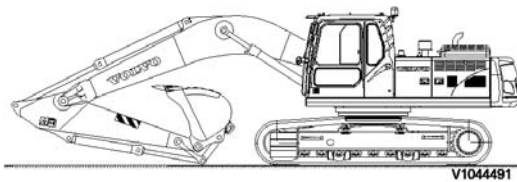

Figure 4
Service position D

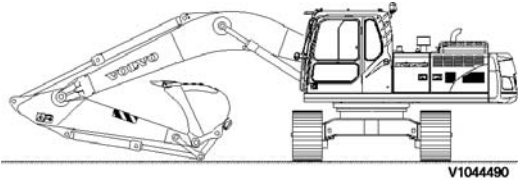

Figure 5
Service position E

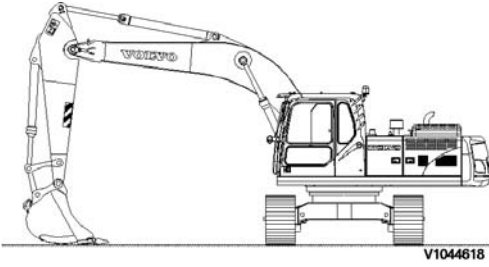

Figure 6
Service position F

Document Title: Safety concerns everybody!	Function Group: 191	Information Type: Service Information	Date: 2015/6/3 0
Profile: EXC, EC460C L [GB]			

Safety concerns everybody!

Always follow the instructions in the machine's Operator's Manual.

The Operator's Manual shall **always** be easily accessible in the cab.

Volvo designs and manufactures machines with a high level of safety as well as effectiveness. All this work may be wasted if anyone who is about to perform service on any of our machines does not read the safety instructions, or does not follow them, e.g., does not replace guards, climbs on slippery machine parts instead of using a ladder, grabs a hold of hoses instead of handles or uses the wrong tools for the job.

Always use the intended and adapted genuine Volvo spare parts for the machine in question to maintain safe and efficient function.

Machines seldom cause accidents, instead people often do.

A safety-conscious person and a well-maintained machine make for a safe, effective and profitable combination.

Those who do not follow the safety instructions and observe the warnings in this manual must make sure that their work method is safe. Otherwise, there is a great risk of accidents, perhaps even accidents that result in fatalities.



WARNING SYMBOL

This symbol appears at various points throughout the manual together with a warning text. It means "Warning, stay alert! Your safety is involved!".

Get to know the capacity and limits of your machine!

Document Title: CE-marking, EMC-directive	Function Group: 191	Information Type: Service Information	Date: 2015/6/3 0
Profile: EXC, EC460C L [GB]			

CE-marking, EMC-directive

CE-marking



Figure 1

(Declaration of conformity, only applies to machines marketed within the EU/EEA).

This machine is CE-marked. This means that, when delivered, the machine meets the applicable "Essential Health and Safety Requirements" specified in EU's so-called Machine Safety Directive, 98/37/EC.

The person making any changes that affect machine safety is also responsible for the same.

As proof that the requirements are fulfilled the machine is supplied with an EU Declaration of Conformity, issued by Volvo CE for every individual machine. This EU declaration also covers attachments manufactured by Volvo CE. The documentation is a valuable document that should be stored in a safe place and retained for at least ten years. **The documentation shall always accompany the machine when it is sold.**

If the machine is used for other purposes or with other attachments than described in this manual, safety must be maintained at all times and in each individual case. The person carrying out such action is also responsible for the action which, in some cases, may require a new CE-marking and the issue of a new EU Declaration of Conformity.

EU EMC Directive

The electronic equipment of the machine may in some cases cause interference with other electronic equipment, or the equipment may be adversely affected by external electromagnetic interference, which may constitute safety risks.

The EU EMC directive on "Electromagnetic conformity" provides a general description of what demands can be made on the machine from a safety perspective, where permitted limits have been determined and given according to international standards.

A machine or device which meets the requirements should be CE-marked. Our machines have been specifically tested for electromagnetic interference. The CE marking of the machine and the declaration of conformity also cover the EMC directive.

If other electronic equipment is fitted to this machine, the equipment must be CE-marked and tested on the machine with regard to electromagnetic interference.

EU's noise directive

Within the EU there is a noise directive stating that a machine may not have noise values that exceed a certain level. The values are indicated on a plate on the outside of the machine. Each machine is also delivered with a noise certificate where Volvo CE assures that the machine fulfills the governing legal requirements. It is important that this certificate accompanies the machine when it is sold.

It is also important that no modifications are made to the machine's noise-damping components in order to fulfill the limit values.

Document Title: Safety when handling the machine	Function Group: 191	Information Type: Service Information	Date: 2015/6/3 0
Profile: EXC, EC460C L [GB]			

Safety when handling the machine

Volvo Construction Equipment is only responsible if:

- the machine has been used correctly and has been maintained according to instructions in Service Manuals and the Operator's Manual.
- prescribed service and prescribed inspections have been performed at the stated intervals.
- the lubricant recommendations in the manual have been followed.
- no safety seals have been opened by unauthorized persons.
- all modifications and repairs have been performed as prescribed by Volvo.
- only Volvo genuine spare parts/accessories or attachments that meet Volvo's requirements have been used.

Machine operators must have sufficient skills and knowledge of the content in the Operator's Manual before operating the machine.

It is important that the operator reads and follows the instructions in the machine's Operator's Manual.

An untrained operator may cause serious injuries and fatalities.

Never operate a excavators for which there is no Operator's Manual available.

Learn to understand the warning plates, symbols and operating instructions for the machine before you start operating.

A few simple safety rules

General

- Repair malfunctions or defects that affect safety as soon as possible.



Suggest:

For more complete manuals. Please go to the home page.

<https://www.ebooklibonline.com>

If the above button click is invalid. Please download this document first, and then click the above link to download the complete manual.

Thank you so much for reading

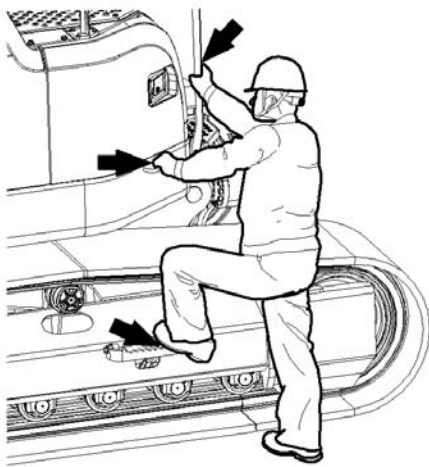

V1068724

Figure 1

Always maintain a three point contact with the steps and handrails

- Always use a hard hat, safety glasses, gloves, protective work shoes and other protective items as required by the work situation.
- Avoid standing in front of or behind the machine when the engine is running.
- Always use a rubber window scraper or brush with a long handle when cleaning the outside of the windows in order to avoid unnecessary climbing on the machine.
- When servicing the machine, for example when changing light bulbs, a ladder may be needed.
- Make sure that stepping surfaces, handles, service areas and anti-slip surfaces are free from oil, diesel, dirt and ice and that they are changed if they are damaged or missing.
- Check at regular intervals that all anti-slip surfaces are securely fastened. If not, fasten or replace as required.
- Always face the machine and use the steps and handrails when entering or leaving the machine. Use two hands and one foot, or two feet and one hand. Do not jump!

Before operating

- Read the Operator's Manual before you operate the machine! Follow the operating instructions and perform actions according to the instructions in the manual before operating.
A few important rules are given below:



Figure 2

Read the operator's manual before you operate the machine

- Perform a control light test before starting the engine by turning the ignition key to position I, see Operator's Manual.
- Perform all recommended safety checks as outlined in the Operator's Manual.

⚠ WARNING

Never operate the machine if you are tired or under the influence of alcohol, medicine or other drugs.

- Before starting the engine indoors, make sure that the extraction capacity of the ventilation system is sufficient. The machine is equipped with a diesel engine and the exhausts may be hazardous to your health. Make sure that ventilation is sufficient, and avoid running the engine indoors for longer than necessary where ventilation is insufficient.
- Read all plates and instructions on the machine and in the Operator's Manual before operating or servicing the machine. Each of these instructions contains important information about safety, handling and service.
- Use the seat belt during all operation.
- Always sit in the operator's seat when starting the engine.
- The machine must be fully operational before it is put into work, that is, all malfunctions that may cause an accident must be repaired.
- Do not operate the machine for long periods without ventilation or with a completely closed cab without running the cab fan (risk of lack of oxygen).
- Only step and stand on surfaces with slip-protected treads and hold on to the available handles and handrails.

Seat belt

- If the seat belt needs to be washed: Use a mild soap solution when washing and allow the belt to dry while it is fully pulled out, before rolling it up. Make sure that the belt is fitted correctly.

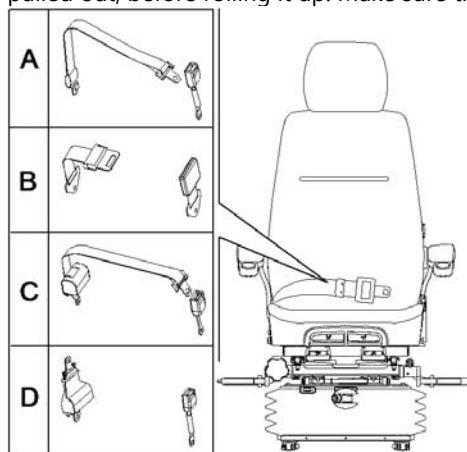

<https://www.ebooklibonline.com>

Hello dear friend!

Thank you very much for reading.

Enter the link into your browser.

The full manual is available for immediate download.

<https://www.ebooklibonline.com>