

Document Title: Power Transmission, description	Function Group: 400	Information Type: Service Information	Date: 2015/11/2
Profile:			

Power Transmission, description

The diesel engine with designation TD 103 KAE drives the excavator's hydraulic system via a pump gearbox. The standard version of the pump gearbox has three pumps for the working hydraulics.

Each track is driven by an axial piston motor. The track brakes, which are of the multi-disc type, are applied by spring force and released hydraulically. Travel motors, brakes and travel gears are enclosed in the track frame.

The superstructure is slewed by means of an axial piston motor. Between the motor and the slew ring are a slew brake, gearbox and slew pinion engaged with the inside of the slew ring. The slew ring works in an oil bath.

Document Title: Travel gearbox for track machine, installation	Function Group: 4311	Information Type: Service Information	Date: 2015/11/2
Profile:			

Travel gearbox for track machine, installation

Op nbr 4311-02

[Track bolt press Art. no. 14 290 046](#)

[Vacuum pump Art. no. 14 360 000](#)

Winch 750 kg

Instruction Manual

Service Manual part 4

1. Loop a strop around the travel gear and connect the strop to a lifting device.

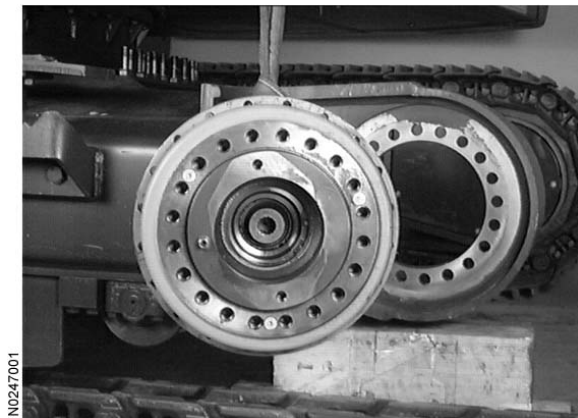

Figure 1
Travel gear

2. Insert the guide pins.



Heavy lift, the travel gear weighs about 360 kg.

3. Fit the travel gear.

NOTE!

Check that the screwhole for mounting the travel motor is aligned with the punch mark in the gearcase seat.

4. Fit the screws **2** (24). **Tightening torque 570 Nm.**
5. Fit the driver **1**.

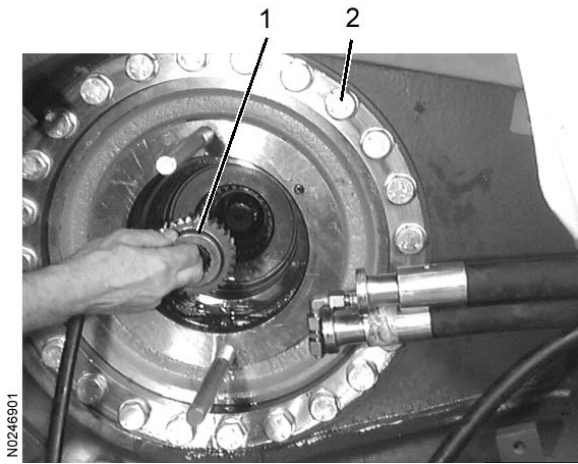

Figure 2
Travel gear

1. Driver
2. Screw

6. Examine the hydraulic motor's O-ring, replace it if it is damaged.
7. Put grease on the travel motor's splined shaft and guide it into the driver.

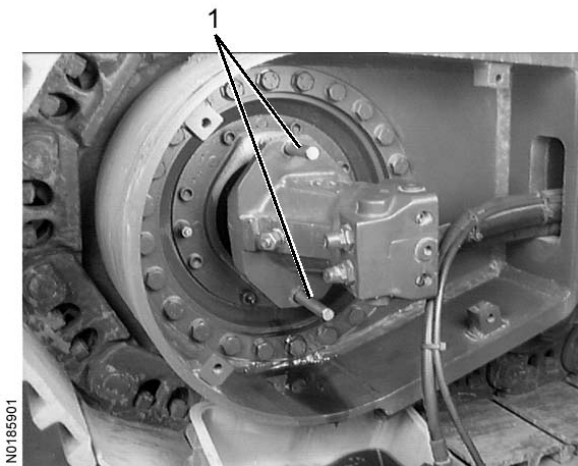

Figure 3
Travel motor

1. Guide pins

NOTE!

Loop a strop in the travel motor and to a lifting device to relieve the weight. This will make the travel motor easier to handle when the splined shaft is guided into the driver. Removing the upper guide pin further facilitates the work. If necessary, rotate the travel motor's splined shaft with waterpump pliers to guide it into the driver.

8. Remove the guide pins and fit the travel motor's screws **1** (2).
Tightening torque 450 Nm.

<https://www.ebooklibonline.com>

Hello dear friend!

Thank you very much for reading.

Enter the link into your browser.

The full manual is available for immediate download.

<https://www.ebooklibonline.com>

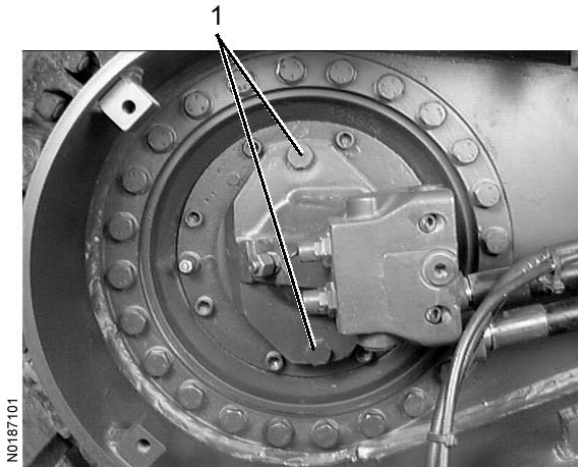

Figure 4
Travel motor

1. Screws

9. Connect and tighten other hoses.
 Hose 1, **Tightening torque 30 Nm.**
 Hose 2, **Tightening torque 75 Nm.**
 Hoses 4 and 5, **Tightening torque 125 Nm** (for the flange halves).

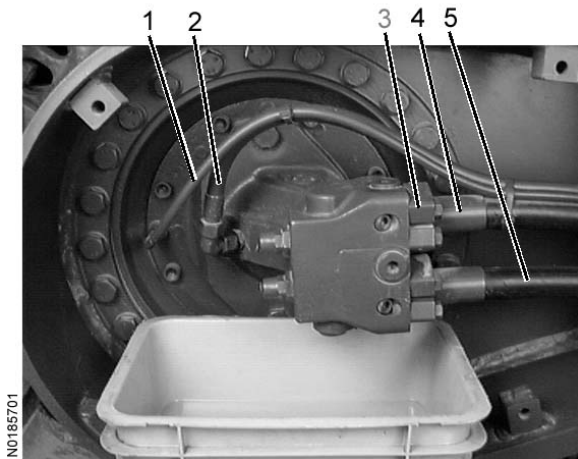

Figure 5
Travel motor

1. Hose
2. Hose
3. Flange half
4. Hose
5. Hose

10. Fill the travel gear with oil, see the *Instruction Manual*.
11. Disconnect the vacuum pump, [Invalid linktarget] .
12. Start the engine and test-drive the machine.
13. Detect and remedy any leakage.
14. Fit harness straps around the hoses to restore the original arrangement.
15. Fit the protective cover. **Tightening torque 90 Nm.**

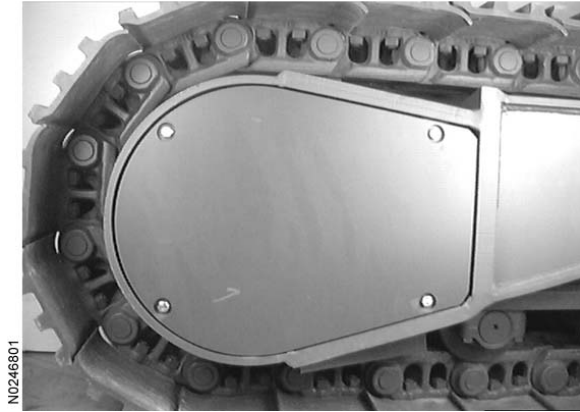

Figure 6
Protective cover

16. Fit and tighten the drive sprocket, [Invalid linktarget] .
17. Press up the undercarriage with the aid of the digging equipment.
18. Remove the chock and lower the undercarriage onto the track chain.
19. Reverse the machine until the top part of the chain engages with the drive sprocket's teeth.



Figure 7
Fitting of track

20. Put the track back on, [Invalid linktarget] .
21. Tension the track, [Invalid linktarget] .

Document Title: Travel gearbox for track machine, removal	Function Group: 4311	Information Type: Service Information	Date: 2015/11/2
Profile:			

Travel gearbox for track machine, removal

Op nbr 4311-01

[Track bolt press Art. no. 14 290 046](#)

[Vacuum pump Art. no. 14 360 000](#)

Winch 750 kg

Guide pins

Collection vessel

Service Manual parts 1 and 4



Hydraulic oil under pressure and hot hydraulic oil can cause severe injuries.

The work involves handling of heavy components and tools, which can cause severe injuries if proper caution is not observed.

1. Park the machine in service position B, but with the superstructure turned across the undercarriage, [Invalid linktarget] .
2. Slacken the track, [Invalid linktarget] .
3. Remove the track, [Invalid linktarget] .
4. Drive the machine forward until the top run of the chain disengages from the drive sprocket's teeth.



N0246501

Figure 1
Disengagement of drive sprocket

5. Drive the machine so that the oil plugs **1** on the planetary gear are oriented as shown in the figure.
6. Remove both plugs **1**.

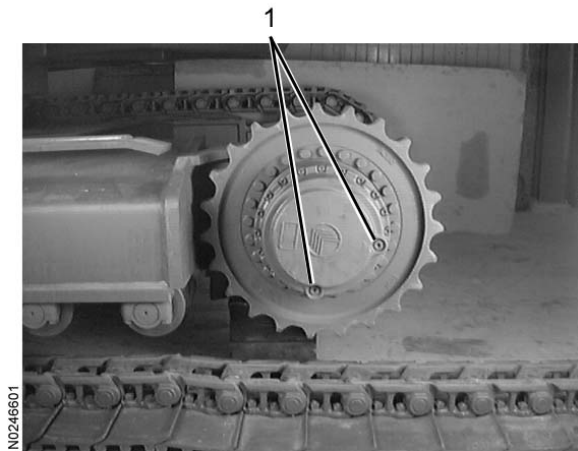

Figure 2
Oil plugs

1. Oil plug
7. Drain the gearbox oil in a clean vessel. (The old oil is not reused when the gearbox is replaced.)
8. Press up the undercarriage with the aid of the digging equipment.
9. Chock up with wooden blocks so that the drive sprocket disengages from the track chain when the undercarriage is resting on the blocks.
10. Lower the undercarriage onto the blocks.
11. Remove the drive sprocket's screws.
12. Lift out the drive sprocket so that a screw can be inserted back through the uppermost hole to attach a strop to.
13. Attach the strop to a lifting device and lift away the drive sprocket.

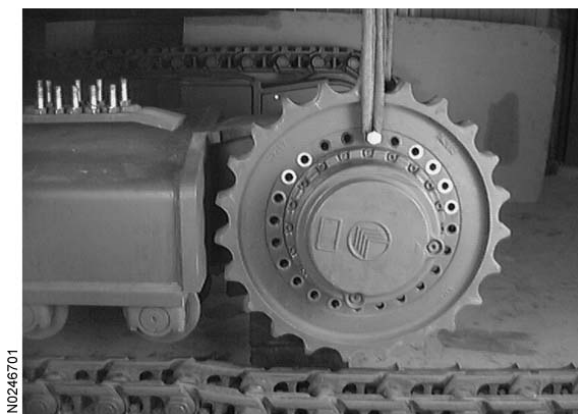

Figure 3
Drive sprocket

14. Connect and start the vacuum pump, [Invalid linktarget] .

15. Remove the protective cover. (The picture was taken before the track was opened.)



Figure 4
Protective cover

16. Place a clean vessel under the hoses.
17. Cut off the harness straps around the hydraulic oil hoses.
18. Disconnect the hoses **1** and **2**, and plug the hoses and the connections.
19. Remove the flange halves **3**.
20. Disconnect and plug the hoses **4** and **5** and the connections.

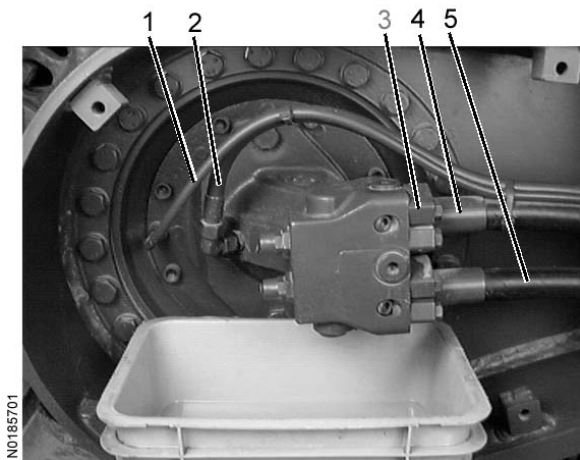

Figure 5
Hoses

1. Hose
2. Hose
3. Flange half
4. Hose
5. Hose

21. Remove the motor's screws **1(2)**.

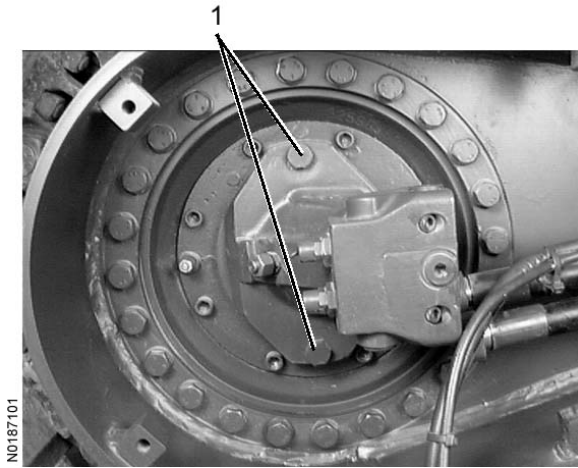

Figure 6
Travel motor

1. Screws
22. Insert the guide pins **1**.
23. Strike with a punch in the gearcase seat at each guide pin before removing the planetary gear to orient the new planetary gear on installation.



Heavy lift, the travel motor weighs around 50 kg.

24. Pull out the motor along the guide pins **1** and lift it away.

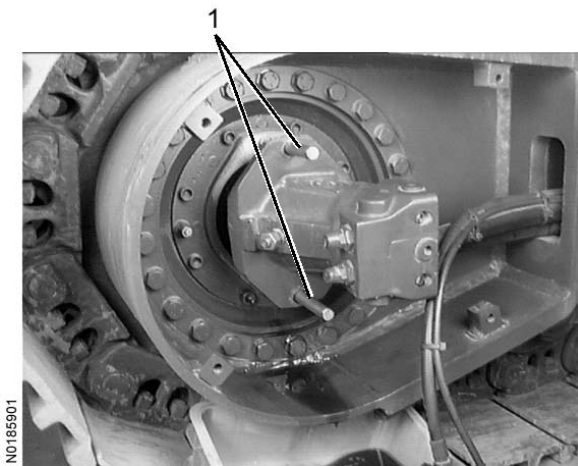

Figure 7
Travel motor

1. Guide pins
25. Loop a strop around the planetary gear and connect it to a lifting device.
26. Tighten the strop so that the gear is held in place.
27. Remove the driver **1**.
28. Remove the screws **2**(24).

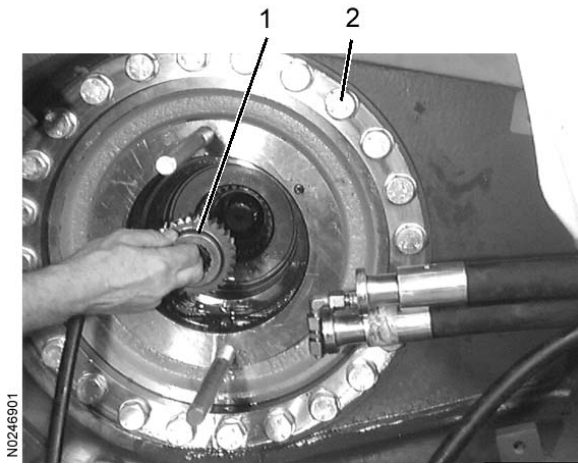

Figure 8
Travel gear

1. Driver
2. Screw



Heavy lift, the travel gear weighs about 360 kg.

29. Lift away the travel gear.

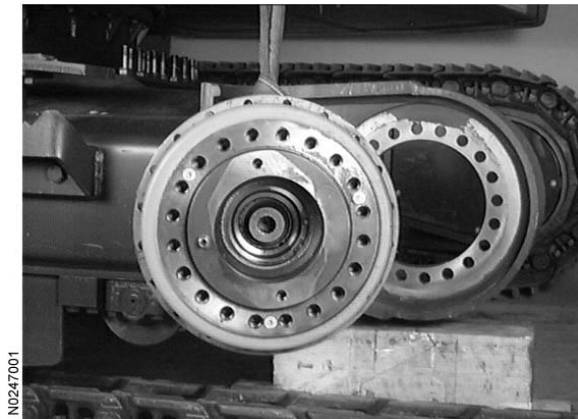

Figure 9
Travel gear

Document Title: Slew gearbox, installation	Function Group: 4312	Information Type: Service Information	Date: 2015/11/2
Profile:			

Slew gearbox, installation

Op nbr 4312-02

=

E-tool, NET 00009 Support

Lift link

Lifting eyebolts M20

Threadlocker Loctite 572

Silicone

Service Manual parts 2 and 4

1. Transfer the lifting eyebolts to the new slew gearbox.
2. Remove the slew speed sensor from the old slew gearbox and install it on the new slew gearbox, [Invalid linktarget] .
3. Thoroughly clean the contact surface **1** in the superstructure.
4. Apply silicone **2** around each screw hole and in the outer edges of the contact surface.

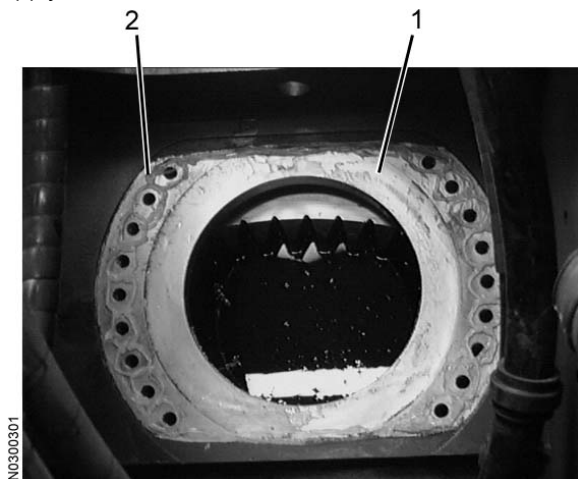

Figure 1
Silicone applied

1. Contact surface
 2. Silicone
5. Lift up the slew gearbox a bit with the aid of a lifting device. Check that the flange surface that will lie against the superstructure is clean.

WARNING

Heavy lift, the slew gearbox weighs about 380 kg.

- Put the slew gearbox in place. Be careful when fitting over the holes so that the slew gearbox comes into the right position immediately.
- Apply threadlocking fluid to the screws and fit them without tightening them.
- Fit the Support **1**, see [Invalid linktarget] and tighten according to the diagram below. **Tightening torque 540 Nm.**

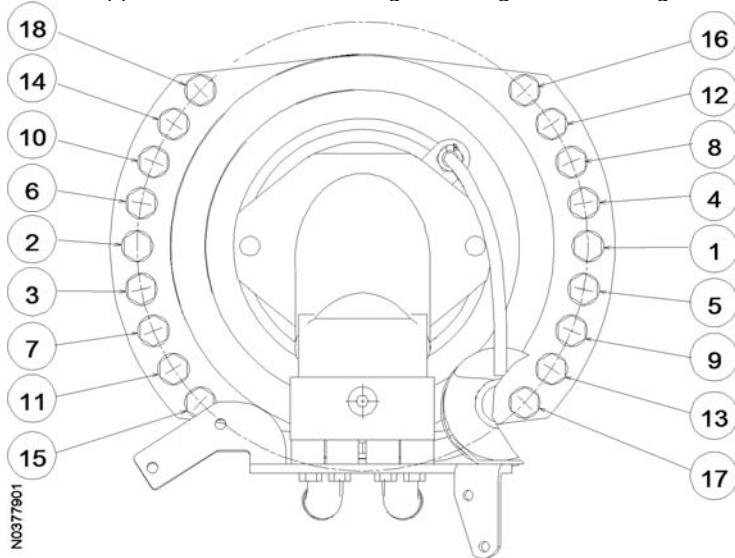

Figure 2
Tightening sequence

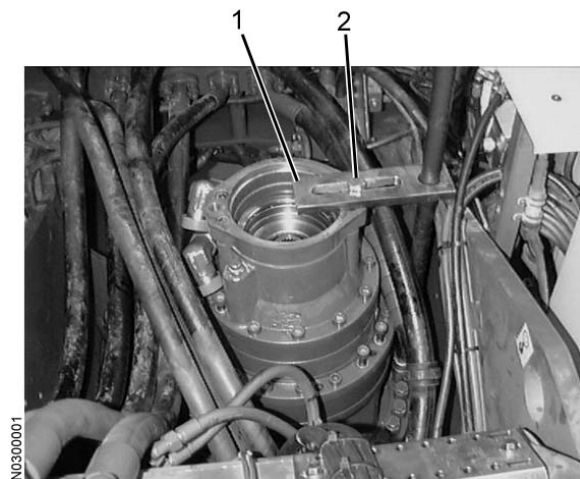

Figure 3
Use of Support

- Support
- Screws (2) for installation of slew motor

- Remove the Support.

WARNING

Heavy lift, the slew motor weighs about 36 kg.

10. Fit the slew motor. **Tightening torque 370 Nm.**
11. Remove the plugs from hydraulic hoses and valve connections.
12. Connect the hydraulic hoses according to previous marking, [Invalid linktarget] .
13. Fit the brackets for the hose retainers.



Figure 4
Brackets installed

14. Fit the hose retainers **1**.

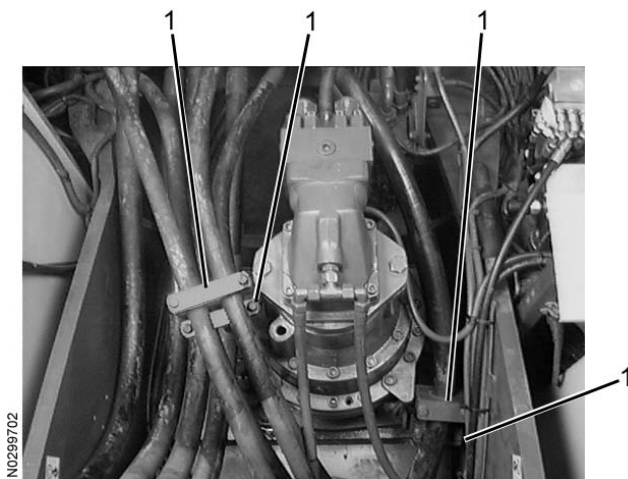

Figure 5
Slew gear

1. Hose retainers

15. Fit the drain pipe **4**. Close the drain tap **2** and refit the plug **1**.

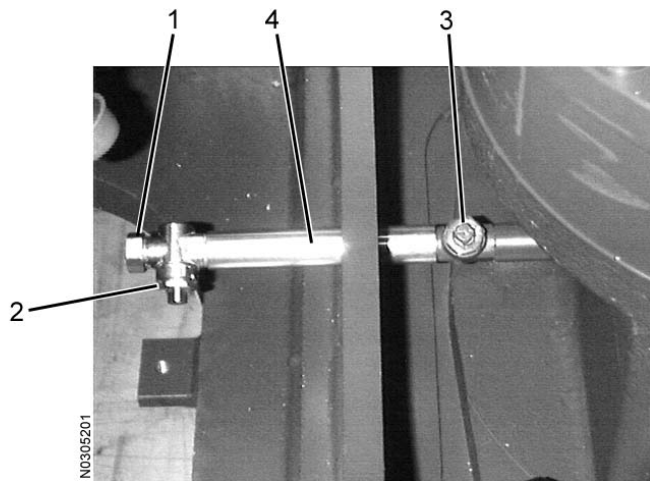

Figure 6
Drain pipe

- 1. Plug
- 2. Drain tap
- 3. Drain tap
- 4. Drain pipe

- 16. Open the drain tap **3**.
- 17. Attach the connector **1** to the slew speed sensor **2**.

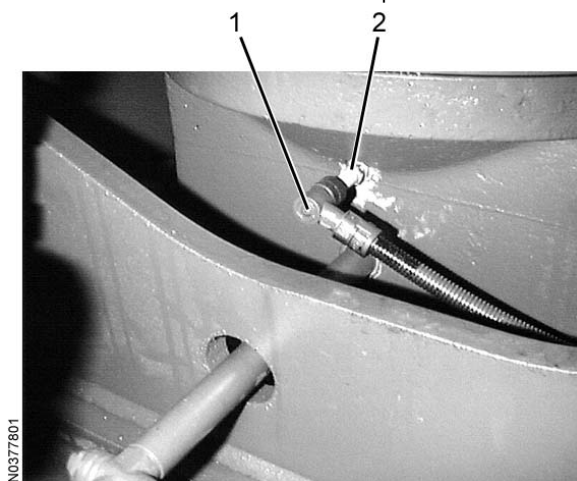

Figure 7
Slew gear

- 1. Connector
- 2. Slew speed sensor

- 18. Disconnect the vacuum pump, [Invalid linktarget] .



Oil should be added carefully, since the gearbox oil can easily bubble up through the filler pipe and cause eye injuries.

- 19. Add 15 l of oil through the vent valve **1**.

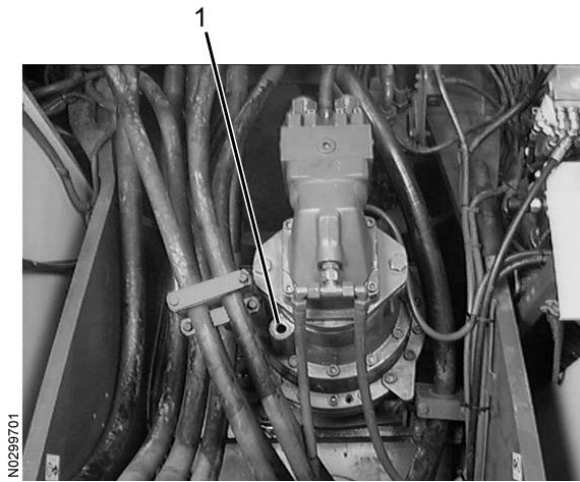

Figure 8
Filling with oil

1. Vent valve
20. Fit the service door in the superstructure. **Tightening torque 67 Nm.**

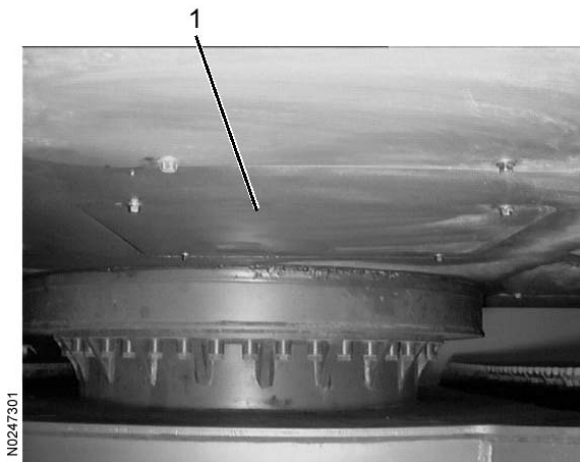

Figure 9
Under the superstructure

1. Service door



Suggest:

For more complete manuals. Please go to the home page.

<https://www.ebooklibonline.com>

If the above button click is invalid. Please download this document first, and then click the above link to download the complete manual.

Thank you so much for reading

Document Title: Slew gearbox, removal	Function Group: 4312	Information Type: Service Information	Date: 2015/11/2
Profile:			

Slew gearbox, removal

Op nbr 4312-01

Vacuum pump Art. no. 14 360 000

E-tool, NET 00009 Support

Lift link

Lifting eyebolts M20

Vessel for at least 20 l, for collection of oil

Plastic hose, inside diameter 3/4"

Service Manual part 4



WARNING

Hydraulic oil under pressure and hot hydraulic oil can cause severe injuries.

1. Connect the vacuum pump, [Invalid linktarget] .
2. **On the bottom of the excavator's superstructure.** Remove the service door **1** in the superstructure.

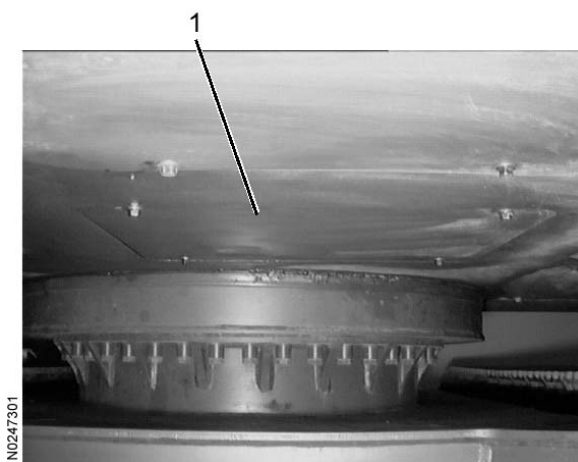

Figure 1
Undercarriage

1. Service door
3. Place the collection vessel for oil on the ground under the opening.

NOTE!

The drain pipe on the excavator may be of two different versions, depending on when the machine was manufactured. If the drain pipe has an extra drain tap **3** next to the trunk on the slew gearbox, skip steps 4-9.

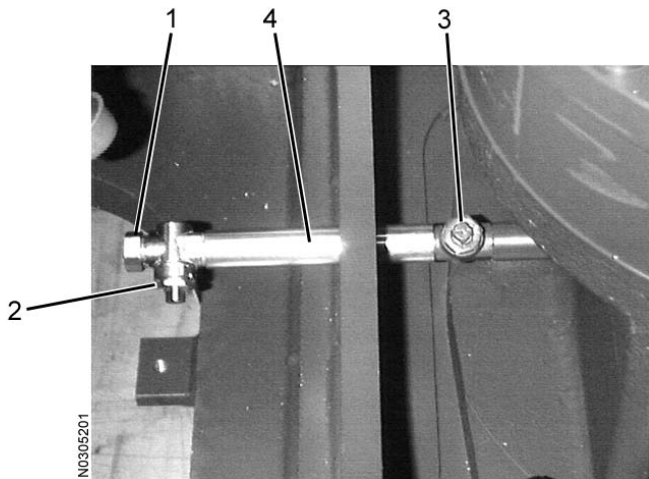

Figure 2
New version of drain pipe

1. Plug
2. Drain tap
3. Drain tap
4. Detachable pipe section

4. Remove the plug **1**.

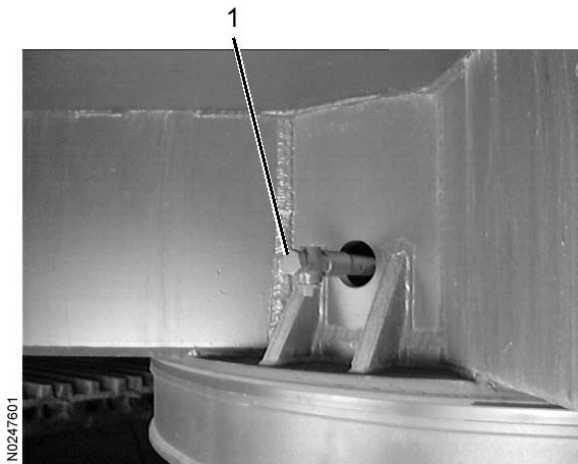

Figure 3
Drain pipe

1. Plug

5. Connect the hose **1**.

6. Open the drain tap **2** and drain the oil.

<https://www.ebooklibonline.com>

Hello dear friend!

Thank you very much for reading.

Enter the link into your browser.

The full manual is available for immediate download.

<https://www.ebooklibonline.com>