

Document Title: Foreword additional Service manual Demolition machine	Function Group: 000	Information Type: Service Information	Date: 2015/4/21
Profile: EXC, EC360B NLC [GB]			

Foreword additional Service manual Demolition machine

This Service manual for Demolition machine built on base machines EC210B, EC240B, EC290B and EC360B.

NOTE!

This is an additional Service manual and should be used together with the Service manual for the base machine.

See Operator's manual for dimensions and weights for the complete machine. Service work on the machine must not be carried out before the instructions in Section "Safety" in both this Service manual and in the base machine Service manual.

For manual reference numbers, see current publications catalogue and SSI (Service Support Information). The operation numbers refer to "Time Guide". The instructions are based on the use of special tools, E-tools and generally available standard tools.

For supplementary information on special tools, see "Special tools." Drawings for E-tools can be found in Section 0 (08) General.

Volvo will not accept any responsibility if any lifting devices, tools or work methods other than those described in this publication are used.

The information and data given in this manual are valid at the time of publication. We reserve the right to modify specifications and equipment without prior notification.

Document Title: Component locations	Function Group: 000	Information Type: Service Information	Date: 2015/4/21
Profile: EXC, EC360B NLC [GB]			

Component locations

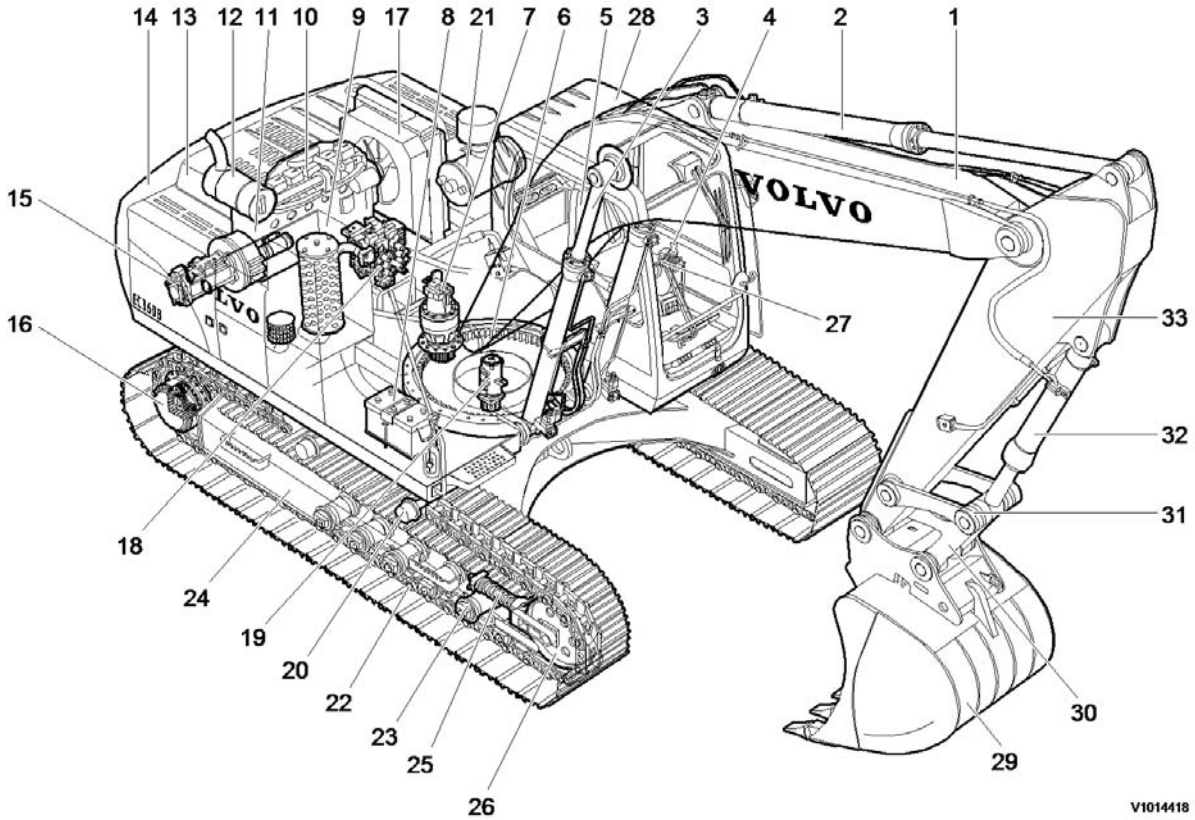

V1014418

Figure 1
Location of components

1 Boom	13 Cowl	25 Recoil spring
2 Arm cylinder	14 Counterweight	26 Idler
3 Boom cylinder	15 Hydraulic pump	27 Control lever (travel)
4 Control lever	16 Track motor and gearbox	28 Operator cab
5 Operator's seat	17 Radiator and oil cooler	29 Bucket
6 Slew ring gear	18 Main control valve	30 Connecting rod
7 Slew motor and gearbox	19 Center passage	31 Link
8 Battery	20 Top roller	32 Bucket cylinder
9 Fuel tank	21 Air cleaner	33 Arm
10 Engine	22 Track link	
11 Hydraulic tank	23 Bottom roller	
12 Muffler	24 Bottom frame	

Document Title: Demolition machine, description	Function Group: 000	Information Type: Service Information	Date: 2015/4/21
Profile: EXC, EC360B NLC [GB]			

Demolition machine, description

The demolition machine is based on a standard machine.

This demolition machine is composed of HD Side door reinforce, Slew ring gear protection cover, Upper frame side protection plate reinforce, Upper under cover reinforce, Boom cylinder protection plate and Bucket cylinder protection plate, Working and maintenance lamps, Top protection round pipe on rear and RH side.

See machine view [000 Machine view, demolition](#).

<https://www.ebooklibonline.com>

Hello dear friend!

Thank you very much for reading.

Enter the link into your browser.

The full manual is available for immediate download.

<https://www.ebooklibonline.com>

Document Title: Machine view, demolition	Function Group: 000	Information Type: Service Information	Date: 2015/4/21
Profile: EXC, EC360B NLC [GB]			

[Go back to Index Page](#)

Machine view, demolition

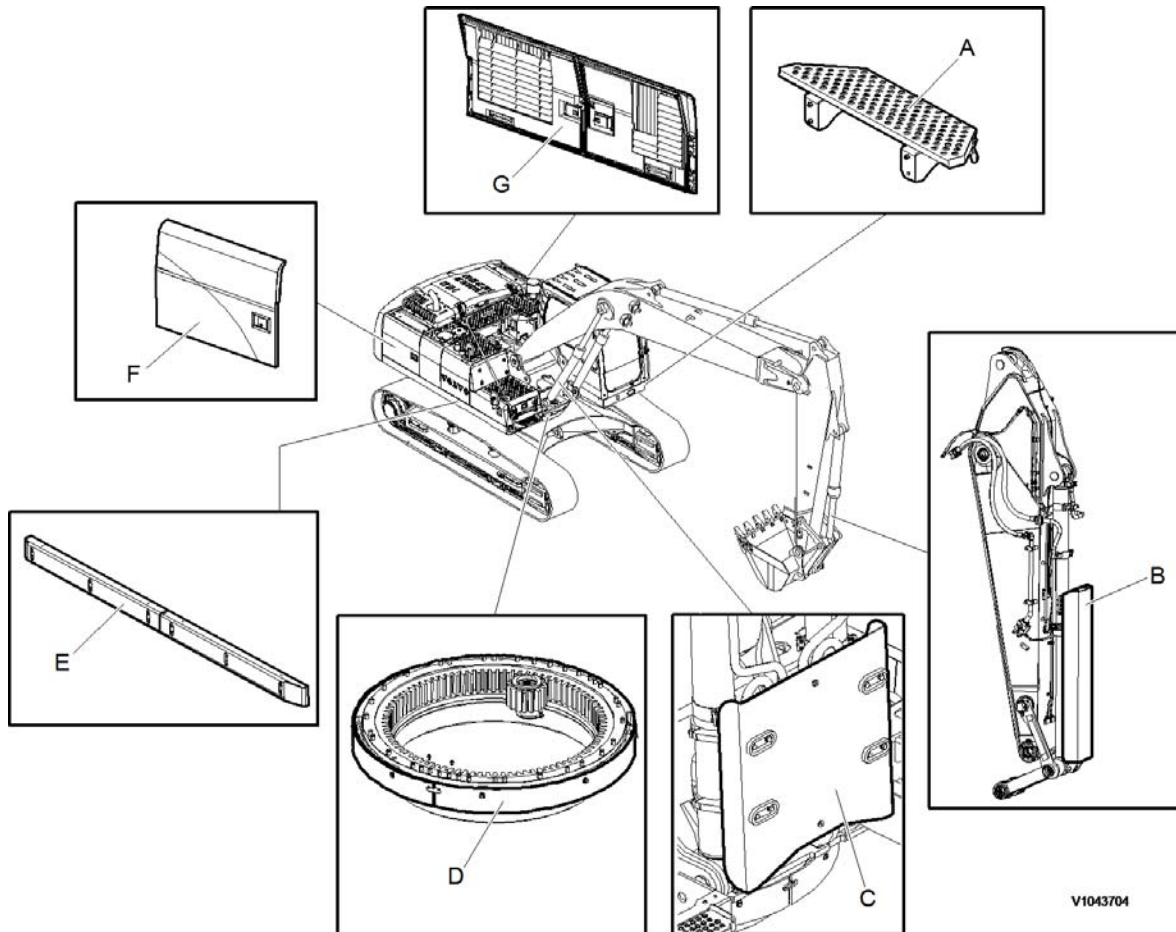

V1043704

Figure 1
Machine view, demolition

- A. Step, Cabin
- B. Bucket cylinder protecting guard
- C. Boom cylinder protecting guard
- D. Swing ring gear cover
- E. Side impact protection
- F. Auxiliary hood, right side door
- G. Auxiliary hood, left side door

Document Title: Machine view, demolition	Function Group: 000	Information Type: Service Information	Date: 2015/4/21
Profile: EXC, EC360B NLC [GB]			

[Go back to Index Page](#)

Machine view, demolition

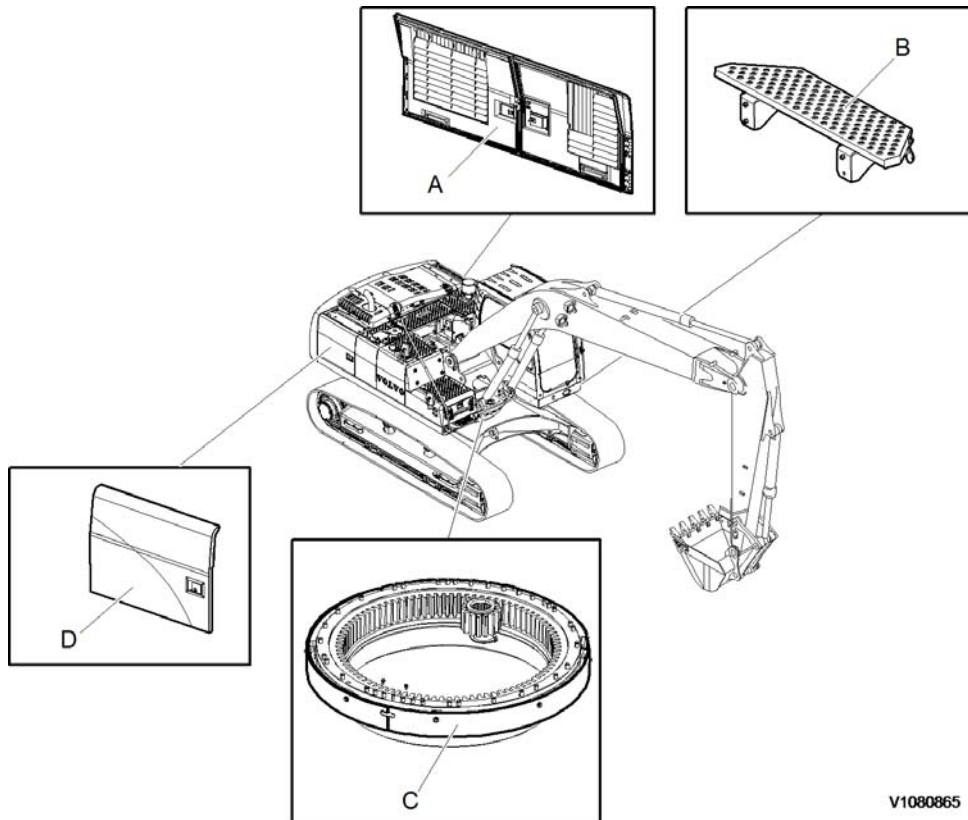

V1080865

Figure 1
Machine view, demolition

- A. Auxiliary hood, left side door
- B. Step, Cabin
- C. Swing ring gear cover
- D. Auxiliary hood, right side door



Suggest:

For more complete manuals. Please go to the home page.

<https://www.ebooklibonline.com>

If the above button click is invalid. Please download this document first, and then click the above link to download the complete manual.

Thank you so much for reading

Document Title: Measurement conversion tables	Function Group: 030	Information Type: Service Information	Date: 2015/4/21
Profile: EXC, EC360B NLC [GB]			

Measurement conversion tables

Length

Unit	cm	m	km	in	ft	yd	mile
cm	1	0.01	0.00001	0.3937	0.03281	0.01094	0.000006
m	100	1	0.001	39.37	3.2808	1.0936	0.00062
km	100000	1000	1	39370.7	3280.8	1093.6	0.62137
in	2.54	0.0254	0.000025	1	0.08333	0.02777	0.000015
ft	30.48	0.3048	0.000304	12	1	0.3333	0.000189
yd	91.44	0.9144	0.000914	36	3	1	0.000568
mile	160930	1609.3	1.6093	63360	5280	1760	1

1 mm = 0.1 cm, 1 mm = 0.001 m

Area

Unit	cm2	m2	km2	a	ft2	yd2	in2
cm2	1	0.0001	-	0.000001	0.001076	0.000012	0.155000
m2	10000	1	0.000001	0.01	10.764	1.1958	1550.000
km2	-	1000000	1	10000	1076400	1195800	-
a	0.01	100	0.0001	1	1076.4	119.58	-
ft2	-	0.092903	-	0.000929	1	0.1111	144.000
yd2	-	0.83613	-	0.008361	9	1	1296.00
in2	6.4516	0.000645	-	-	0.006943	0.000771	1

1 ha = 100 a, 1 mile² = 259 ha = 2.59 km²

Volume

Unit	cm3 = cc	m3	Liter	in3	ft3	yd3
cm3 = m liter	1	0.000001	0.001	0.061024	0.000035	0.000001
m3	1000000	1	1000	61024	35.315	1.30796
Liter	1000	0.001	1	61.024	0.035315	0.001308
in3	16.387	0.000016	0.01638	1	0.000578	0.000021
ft3	28316.8	0.028317	28.317	1728	1	0.03704
yd3	764529.8	0.76453	764.53	46656	27	1

1 gal(US) = 3785.41 cm³ = 231 in³ = 0.83267 gal(US)

Weight

Unit	g	kg	t	oz	lb
g	1	0.001	0.000001	0.03527	0.0022
kg	1000	1	0.001	35.273	2.20459

t	1000000	1000	1	35273	2204.59
oz	28.3495	0.02835	0.000028	1	0.0625
lb	453.592	0.45359	0.000454	16	1
1 tonne(metric) = 1.1023 ton(US) = 0.9842 ton(UK)					

Pressure

Unit	kgf/cm ²	bar	Pa=N/m ²	kPa	lbf/in ²	lbf/ft ²
kgf/cm ²	1	0.98067	98066.5	98.0665	14.2233	2048.16
bar	1.01972	1	100000	100	14.5037	2088.6
Pa=N/m ²	0.00001	0.001	1	0.001	0.00015	0.02086
kPa	0.01020	0.01	1000	1	0.14504	20.886
lbf/in ²	0.07032	0.0689	6894.76	6.89476	1	144
lbf/ft ²	0.00047	0.00047	47.88028	0.04788	0.00694	1
1 kgf/cm ² = 735.56 Torr(mmHg) = 0.96784 atm						

Approximate conversions

SI	Conversion	Non-SI	Conversion	SI
Unit	Factor	Unit	Factor	Unit
Torque				
newton meter (N·m)	x 10.2	= kgf·cm	x 0.8664	= (lbf·in)
newton meter (N·m)	x 0.74	= lb·ft	x 1.36	= N·m
newton meter (N·m)	x 0.102	= kgf·m	x 7.22	= (lbf·ft)
Pressure (Pa = N/m²)				
kilopascal (kPa)	x 4.0	= in. H ₂ O	x 0.249	= kPa
kilopascal (kPa)	x 0.30	= in. Hg	x 3.38	= kPa
kilopascal (kPa)	x 0.145	= psi	x 6.89	= kPa
(bar)	x 14.5	= psi	x 0.069	= (bar)
(kgf/cm ²)	x 14.22	= psi	x 0.070	= (kgf/cm ²)
(newton/mm ²)	x 145.04	= psi	x 0.069	= (bar)
megapascal (MPa)	x 145	= psi	x 0.00689	= MPa
Power (W = J/s)				
kilowatt (kW)	x 1.36	= PS (cv)	x 0.736	= kW
kilowatt (kW)	x 1.34	= HP	x 0.746	= kW
kilowatt (kW)	x 0.948	= Btu/s	x 1.055	= kW
watt (W)	x 0.74	= ft·lb/s	x 1.36	= W
Energy (J = N·m)				
kilojoule (kJ)	x 0.948	= Btu	x 1.055	= kJ
joule (J)	x 0.239	= calorie	x 4.19	= J
Velocity and Acceleration				
meter per sec ² (m/s ²)	x 3.28	= ft/s ²	x 0.305	= m/s ²
meter per sec (m/s)	x 3.28	= ft/s	x 0.305	= m/s
kilometer per hour (km/h)	x 0.62	= mph	x 1.61	= km/h
Horse power/torque				
BHP x 5252 rpm = TQ (lb·ft)			TQ x rpm 5252 = B.H.P.	
Temperature				
°C = (°F - 32) / 1.8		°F = (°C x 1.8) + 32		
Flow Rate				

<https://www.ebooklibonline.com>

Hello dear friend!

Thank you very much for reading.

Enter the link into your browser.

The full manual is available for immediate download.

<https://www.ebooklibonline.com>