

Document Title: Safety concerns everybody!	Function Group: 191	Information Type: Service Information	Date: 2015/4/13
Profile: EXC, EC330C L [GB]			

Safety concerns everybody!

Always follow the instructions in the machine's Operator's Manual.

The Operator's Manual shall **always** be easily accessible in the cab.

Volvo designs and manufactures machines with a high level of safety as well as effectiveness. All this work may be wasted if anyone who is about to perform service on any of our machines does not read the safety instructions, or does not follow them, e.g., does not replace guards, climbs on slippery machine parts instead of using a ladder, grabs a hold of hoses instead of handles or uses the wrong tools for the job.

Always use the intended and adapted genuine Volvo spare parts for the machine in question to maintain safe and efficient function.

Machines seldom cause accidents, instead people often do.

A safety-conscious person and a well-maintained machine make for a safe, effective and profitable combination.

Those who do not follow the safety instructions and observe the warnings in this manual must make sure that their work method is safe. Otherwise, there is a great risk of accidents, perhaps even accidents that result in fatalities.



WARNING SYMBOL

This symbol appears at various points throughout the manual together with a warning text. It means "Warning, stay alert! Your safety is involved!".

Get to know the capacity and limits of your machine!

Document Title: CE-marking, EMC-directive	Function Group: 191	Information Type: Service Information	Date: 2015/4/13
Profile: EXC, EC330C L [GB]			

CE-marking, EMC-directive

CE-marking



Figure 1

(Declaration of conformity, only applies to machines marketed within the EU/EEA).

This machine is CE-marked. This means that, when delivered, the machine meets the applicable "Essential Health and Safety Requirements" specified in EU's so-called Machine Safety Directive, 98/37/EC.

The person making any changes that affect machine safety is also responsible for the same.

As proof that the requirements are fulfilled the machine is supplied with an EU Declaration of Conformity, issued by Volvo CE for every individual machine. This EU declaration also covers attachments manufactured by Volvo CE. The documentation is a valuable document that should be stored in a safe place and retained for at least ten years. **The documentation shall always accompany the machine when it is sold.**

If the machine is used for other purposes or with other attachments than described in this manual, safety must be maintained at all times and in each individual case. The person carrying out such action is also responsible for the action which, in some cases, may require a new CE-marking and the issue of a new EU Declaration of Conformity.

EU EMC Directive

The electronic equipment of the machine may in some cases cause interference with other electronic equipment, or the equipment may be adversely affected by external electromagnetic interference, which may constitute safety risks.

The EU EMC directive on "Electromagnetic conformity" provides a general description of what demands can be made on the machine from a safety perspective, where permitted limits have been determined and given according to international standards.

A machine or device which meets the requirements should be CE-marked. Our machines have been specifically tested for electromagnetic interference. The CE marking of the machine and the declaration of conformity also cover the EMC directive.

If other electronic equipment is fitted to this machine, the equipment must be CE-marked and tested on the machine with regard to electromagnetic interference.

EU's noise directive

Within the EU there is a noise directive stating that a machine may not have noise values that exceed a certain level. The values are indicated on a plate on the outside of the machine. Each machine is also delivered with a noise certificate where Volvo CE assures that the machine fulfills the governing legal requirements. It is important that this certificate accompanies the machine when it is sold.

It is also important that no modifications are made to the machine's noise-damping components in order to fulfill the limit values.

Document Title: Safety when handling the machine	Function Group: 191	Information Type: Service Information	Date: 2015/4/13
Profile: EXC, EC330C L [GB]			

Safety when handling the machine

Volvo Construction Equipment is only responsible if:

- the machine has been used correctly and has been maintained according to instructions in Service Manuals and the Operator's Manual.
- prescribed service and prescribed inspections have been performed at the stated intervals.
- the lubricant recommendations in the manual have been followed.
- no safety seals have been opened by unauthorized persons.
- all modifications and repairs have been performed as prescribed by Volvo.
- only Volvo genuine spare parts/accessories or attachments that meet Volvo's requirements have been used.

Machine operators must have sufficient skills and knowledge of the content in the Operator's Manual before operating the machine.

It is important that the operator reads and follows the instructions in the machine's Operator's Manual.

An untrained operator may cause serious injuries and fatalities.

Never operate a excavators for which there is no Operator's Manual available.

Learn to understand the warning plates, symbols and operating instructions for the machine before you start operating.

A few simple safety rules

General

- Repair malfunctions or defects that affect safety as soon as possible.

<https://www.ebooklibonline.com>

Hello dear friend!

Thank you very much for reading.

Enter the link into your browser.

The full manual is available for immediate download.

<https://www.ebooklibonline.com>

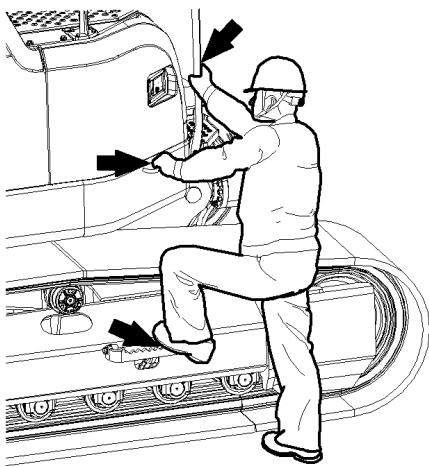
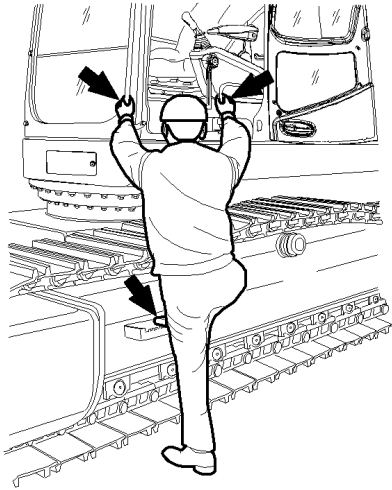

V1068724

Figure 1

Always maintain a three point contact with the steps and handrails

- Always use a hard hat, safety glasses, gloves, protective work shoes and other protective items as required by the work situation.
- Avoid standing in front of or behind the machine when the engine is running.
- Always use a rubber window scraper or brush with a long handle when cleaning the outside of the windows in order to avoid unnecessary climbing on the machine.
- When servicing the machine, for example when changing light bulbs, a ladder may be needed.
- Make sure that stepping surfaces, handles, service areas and anti-slip surfaces are free from oil, diesel, dirt and ice and that they are changed if they are damaged or missing.
- Check at regular intervals that all anti-slip surfaces are securely fastened. If not, fasten or replace as required.
- Always face the machine and use the steps and handrails when entering or leaving the machine. Use two hands and one foot, or two feet and one hand. Do not jump!

Before operating

- Read the Operator's Manual before you operate the machine! Follow the operating instructions and perform actions according to the instructions in the manual before operating.
A few important rules are given below:



V1039704

Figure 2

Read the operator's manual before you operate the machine

- Perform a control light test before starting the engine by turning the ignition key to position I, see Operator's Manual.
- Perform all recommended safety checks as outlined in the Operator's Manual.



Never operate the machine if you are tired or under the influence of alcohol, medicine or other drugs.

- Before starting the engine indoors, make sure that the extraction capacity of the ventilation system is sufficient. The machine is equipped with a diesel engine and the exhausts may be hazardous to your health. Make sure that ventilation is sufficient, and avoid running the engine indoors for longer than necessary where ventilation is insufficient.
- Read all plates and instructions on the machine and in the Operator's Manual before operating or servicing the machine. Each of these instructions contains important information about safety, handling and service.
- Use the seat belt during all operation.
- Always sit in the operator's seat when starting the engine.
- The machine must be fully operational before it is put into work, that is, all malfunctions that may cause an accident must be repaired.
- Do not operate the machine for long periods without ventilation or with a completely closed cab without running the cab fan (risk of lack of oxygen).
- Only step and stand on surfaces with slip-protected treads and hold on to the available handles and handrails.

Seat belt

- If the seat belt needs to be washed: Use a mild soap solution when washing and allow the belt to dry while it is fully pulled out, before rolling it up. Make sure that the belt is fitted correctly.

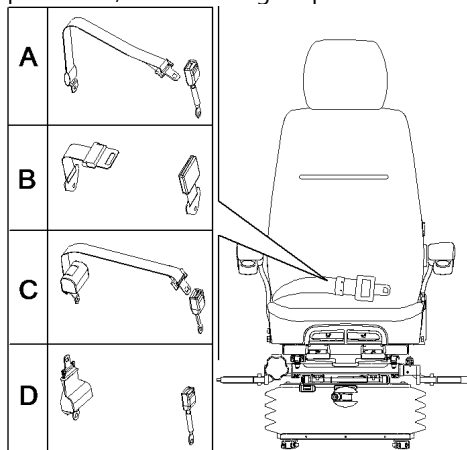

V1048174

Figure 3
Use the seat belt during all operation

- A. Strap lap type (2 inches)
- B. Strap lap type (3 inches)
- C. Retractable type (2 inches)

- Change the belt immediately if it is worn, damaged or if the machine has been involved in an accident where the belt had to take some strain.
- Never make changes to the belt or its mounts.
- Keep the belt rolled up when not in use.

Control lockout system

Move the control lockout lever down to lock the hydraulic system securely. Unless the control lockout lever is on the "Locked" position (B), operating levers can be operated by careless touch, which could cause serious injury.

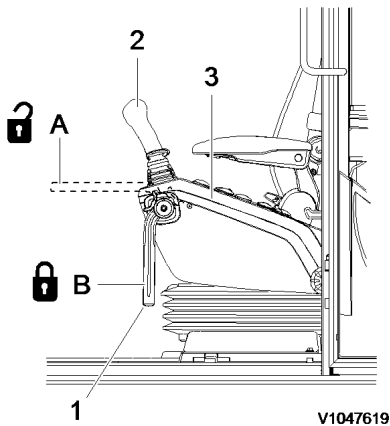

Figure 4
Control lockout lever

- 1 Control lockout lever
- 2 Left control lever
- 3 Left control console
- A Unlocked position
- B Locked position

Unlocked position (A)

- The control lockout lever is in "Unlocked" position (A) for working and travelling operations.
- **When the control lockout lever is in this position the engine can not be started.**

Locked position (B)

- The control lockout lever is used to **lock-out** the attachment, slew and travel unit.
- Place this lever on the left control console to "Locked" position (B) to lock out the hydraulic control levers and pedals.
- **When the control lockout lever is in this position the engine can be started.**

NOTE!

In manual control mode, the engine can be started using the ignition switch even if the control lockout lever is in the unlocked (up) position. Place the control lockout lever in locked position to lock the hydraulics before starting the engine, otherwise the control levers can be activated inadvertently, which could cause serious injury.

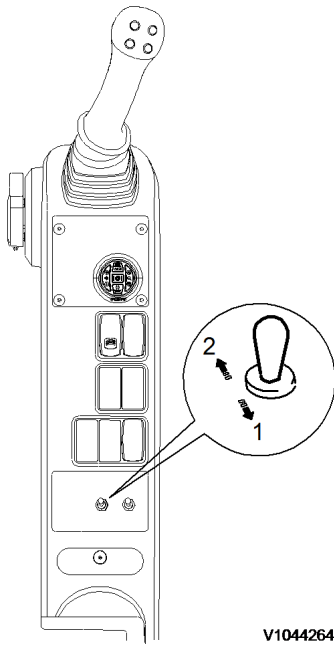

V1044264

Figure 5
Automatic/manual pump control switch

1. Manual control
2. Automatic control

Theft protection system

The machine can be equipped with theft protection in the form of a code lock (See Operator's Manual) which prevents start of the machine without the correct four-digit code. Do not forget the code. It can only be programmed and changed via VCADS Pro. If you forget the code, contact your dealer.

Document Title: Safety rules when servicing	Function Group: 191	Information Type: Service Information	Date: 2015/4/13
Profile: EXC, EC330C L [GB]			

Safety rules when servicing

This section covers general safety rules when checking and servicing. Other rules, information and warning texts are given in the Operator's Manual.

CE-marking

This machine is CE-marked. This means that, when delivered, the machine meets the applicable "Essential Health and Safety Requirements", which are given in the EU Machine Safety Directive. If changes are made that affect the safety of the machine, the person making the changes is responsible for the same.

Therefore, the following applies: See further [191 CE-marking, EMC-directive](#).

Before you begin any service work:

Service work done incorrectly is dangerous.

Make sure that you have sufficient knowledge, correct information, the right tools and the correct equipment to perform the service in a correct manner.

Repair or replace damaged tools and defective equipment.

Park the machine on a level surface and prepare it for service by placing it in the service position according to figure:

Service position

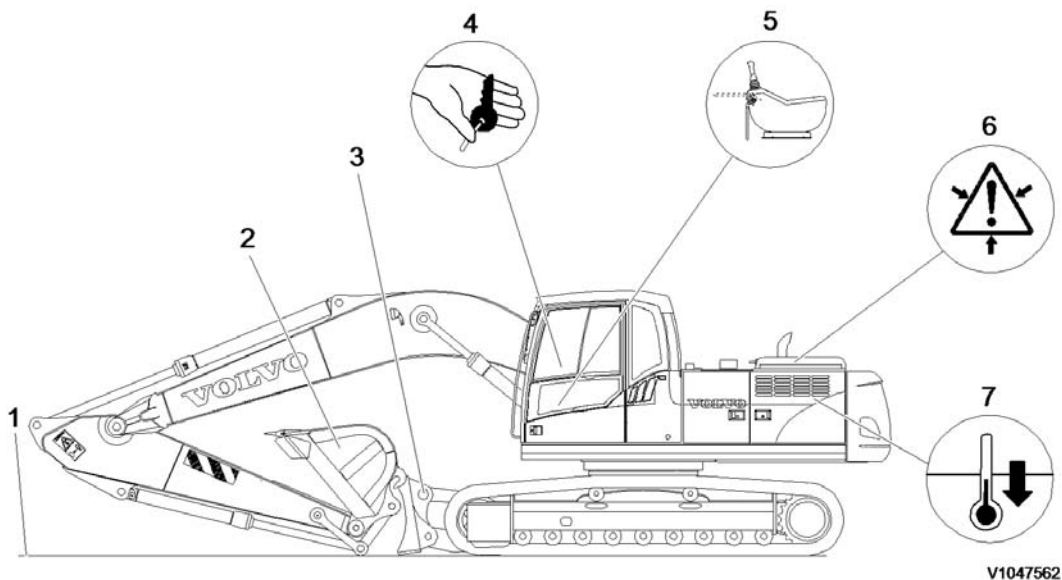

V1047562

Figure 1

Service position

1. Position the machine on even, firm and level ground.
2. Attachment resting on the ground.
3. Dozer blade resting on the ground if equipped.
4. Engine turned off and the ignition key removed.
5. Move the control lockout lever down to lock the system securely. Refer to the Operator's Manual for detailed information.
6. Pressurized lines and vessels should have the pressure released gradually to avoid risks.
7. Allow the machine to cool down. (If you have to work on a machine before it has cooled down, beware of hot fluids and components which can cause burns.

NOTE!

No work may be done on the machine until you have the correct skills and knowledge of the machine to do the work.

General

- Machine working in an environmentally contaminated area, See [191 Working in environmentally contaminated areas](#). See also [191 Checklist after a fire or heat exposure](#).
- If someone is to take over the job that you have started, make sure that this person is informed about what part of the work has been completed and what remains to be done.
- When high-pressure washing the machine, do not aim the water jet directly at anti-slip surfaces or decals that are glued on.

WARNING

Only walk or step on the machine's prepared stepping surfaces, see operator's manual.

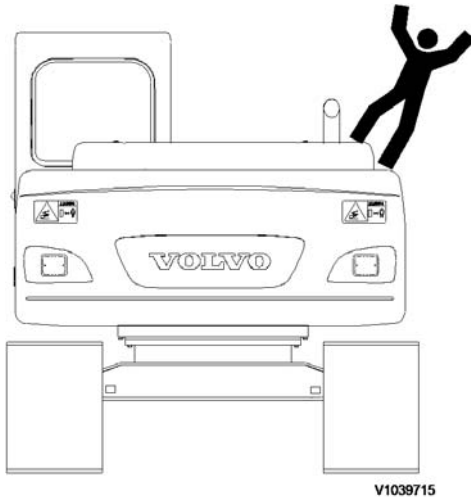

Figure 2

Do not step on engine covers

- Never wear loose fitting clothing, for example, a scarf or jewelry, that can get caught and cause injury when working on the machine.

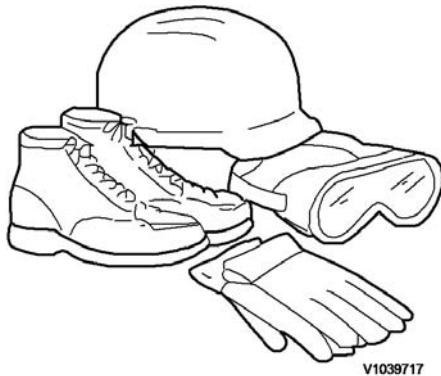

Figure 3

Protective equipment

- Always use a hard hat, safety glasses, gloves, protective work shoes and other protective items as required by the work situation.
- Always stop the engine when servicing the machine unless instructions on plates or in this manual state otherwise.
- Turn off the engine before opening engine covers, radiator casing, etc. Make sure that no tools or other objects that can cause damage are forgotten in the machine.
- Pay attention when removing or installing the tracks of track type machines. When removing the track pin, the track separates suddenly, so never let anyone stand at either end of the track. Always blocks both ends of the track to prevent any sudden uncontrolled movement.

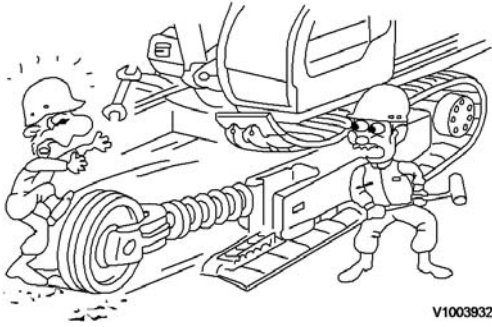

Figure 4

Pay attention when removing or installing the tracks

- Pay attention when removing or installing the master pin of the track using a press, the master pin may pop out suddenly, so never let anyone stand at either end of the master pin.

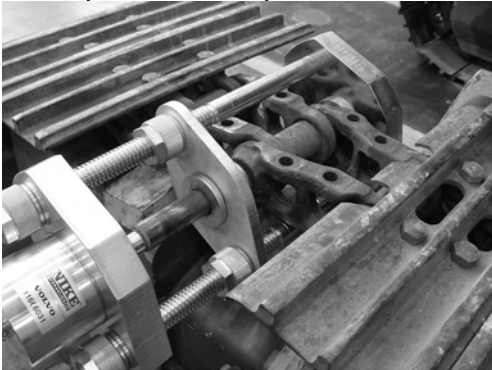

Figure 5

Pay attention when removing or installing the master pin

Document Title: Fire prevention measures	Function Group: 191	Information Type: Service Information	Date: 2015/4/13
Profile: EXC, EC330C L [GB]			

Fire prevention measures

General

- There is always a risk of fire. Find out which type of fire extinguisher to use, where it is located and how to use it. The fire extinguisher in the machine should be located according to the figure or in an external box that can be locked.
- Fire-fighting equipment installed in or on the machine must be maintained in working order. Such equipment should be regarded as a complement to the operator's own efforts in case of a fire. The equipment should not be considered as a replacement of the operator's own fire fighting efforts.
- Fire extinguishers mounted on the machine or used when working on the machine must fulfil certain requirements. See the Operator's Manual.
- At the slightest sign of fire, if the situation allows it and keeping in mind your own safety, take the following action:
 - drive the machine away from the danger area.
 - stop the engine by turning the ignition key to the "0" position.
 - leave the cab.
 - turn off the battery disconnect switch.
 - start fighting the fire and call the fire department if necessary.



Figure 2

Smoking and open flames are absolutely forbidden when filling fuel or any time diesel fuel is in contact with the open air.

- Smoking or open flames are absolutely forbidden close to the machine when filling fuel or at any time the fuel system is in contact with the open air.
- Diesel fuel is flammable and must not be used for cleaning. Use an approved solvent instead.
- Remember that certain solvents can cause skin rashes and are usually flammable. Avoid inhaling solvent vapour.
- Engine starting aids are flammable. Store such items in cool and adequately ventilated areas. Remember that such aids must not be used in combination with electric preheating of induction air.

Cleanliness

- Cleanliness is a decisive factor for operational reliability of the machine's systems. Therefore, keep the servicing area clean. Oil or water make floors and steps slippery and are also dangerous in combination with electrical systems or tools. Oily clothes or clothes drenched in grease constitute a serious fire hazard.

NOTICE

If a high-pressure washer is used when cleaning, work carefully since damage may be caused to electrical components and insulation of the electrical cabling even at relatively moderate water pressure and temperature. Protect electrical cabling in a suitable manner.

- Keep the machine especially clean when operating in environments with fire hazards, such as saw mills, garbage dumps, etc. In such environments, suitable equipment to reduce the risk of accumulation of material and spontaneous combustion should be fitted (for example muffler guard, radiator screen, heavy-duty cyclone pre-cleaner, etc.).

Electrical system

- Check electrical cables with regard to chafing damage and make sure that they cannot be damaged in such a way. This applies particularly to unfused electrical cables, which are red.
For example, electrical cables between:
 - Batteries
 - Battery–starter motor
 - Alternator–starter motor
 - Cable to engine preheating coil.
- When unfused cables have been disconnected, it is important to check that they are re-connected and clamped in such a way that they cannot be exposed to chafing. Unfused cables must not rest against oil and fuel hoses.
- When fitting any optional equipment, make sure that all cables (circuits) are connected across a fuse and routed and clamped so that there is no risk of chafing.

Welding and grinding

- Welding and grinding on the machine may only be performed on well-cleaned areas and not in places filled with combustible fluids, e.g., tanks, hydraulic pipes.
Work with extra care when welding and grinding near flammable objects.
- Never weld on a painted surface without first removing the paint. Welding on a painted surface generates, in addition to health-hazardous vapours, technically inferior welds which may lead to future failures, with subsequent accidents.
Use personal protective equipment and, where possible, air extraction shall be used to handle gases from welding and grinding.

Actions after a fire: See [191 Checklist after a fire or heat exposure](#).

Document Title: Health hazards with paint, plastics and rubber	Function Group: 191	Information Type: Service Information	Date: 2015/4/13
Profile: EXC, EC330C L [GB]			

Health hazards with paint, plastics and rubber

Work on painted surfaces

Never weld or cut with a torch on painted surfaces. All paint decomposes when heated and generates a vast number of different substances that may be irritating and, in case of repeated exposure, be very hazardous to health

The following safety actions shall be followed:

- Remove the paint by sandblasting at least 100 mm (3.93 inch) around the welding or cutting point (use breathing mask).
If the paint cannot be removed by sandblasting, then remove the paint in another way, e.g., with paint solvent/remover.
NOTE!
When using paint remover/solvent, use air extraction, breathing protection and protective work gloves.
- Grinding machines with high-speed grinding discs also heat the paint and may only be used if there is an air extractor on the grinder. Use breathing protection as well.

Rubber and plastics



WARNING

When heated, rubber and plastics can give off substances that are hazardous to personal health and the environment.

The following safety instructions shall be followed:

- Do not weld or cut with a torch near polymer materials (plastics and rubber) without first protecting them from the heat.
- Never burn polymer materials when scrapping them.
- Be careful when handling machines that have been exposed to fire or other intense heat. See also [191 Checklist after a fire or heat exposure](#).
- Always use gloves, protective safety glasses and breathing protection.

Fluor rubber



WARNING

Risk of serious corrosive injuries!

Certain seals designed to withstand high operating temperatures (e.g., in engines, transmissions, axles, brakes, hydraulic motors and pumps) may be made of fluor rubber which, when heated to high temperatures, generate hydrogen fluoride and hydrofluoric acid.

Hydrofluoric acid is highly acidic and corrosive. It cannot be rinsed or washed off the skin and causes very severe burn and corrosive injuries that take a very long time to heal. As a rule, injured tissue must be removed surgically.

Hydrofluoric acid may remain on machine parts for a very long time (several years) after a fire.

NOTE!

In case of contact with hydrofluoric acid, it may take several hours before any symptoms appear.

If swelling, redness or burning sensations appear and contact with heated fluor rubber is suspected to be the cause, seek immediate medical attention. If a machine or a component for a machine has been exposed to fire or other intense heat it shall be handled by specially trained personnel.

For all handling of machines after a fire, use heavy-duty gloves made of neoprene rubber and effective safety goggles.



Burning of painted parts, plastic or rubber parts constitutes a health hazard.

See [191 Environmentally safe handling](#).

Decontamination

The area around a heated part that is suspected to be made of fluor rubber shall be decontaminated by thorough and ample washing with lime water (a solution or suspension of calcium hydroxide, that is, slaked lime) in water. After completing the decontamination work, wash the gloves in the lime water and then discard them.

If the machine has been exposed to a fire or other intense heat, the safety actions in the following checklist shall be followed unconditionally at all times: [191 Checklist after a fire or heat exposure](#).

Asbestos information

The components in Volvo CE's machines are free from asbestos, that is why it is important to use genuine Volvo spare parts.



Suggest:

For more complete manuals. Please go to the home page.

<https://www.ebooklibonline.com>

If the above button click is invalid. Please download this document first, and then click the above link to download the complete manual.

Thank you so much for reading

Document Title: Checklist after a fire or heat exposure	Function Group: 191	Information Type: Service Information	Date: 2015/4/13
Profile: EXC, EC330C L [GB]			

Checklist after a fire or heat exposure

- As a precaution, seal rings (O-rings or axle/shaft seals) should always be handled as if they were made of fluor rubber, See also section "Fluor rubber".

WARNING

Avoid splashing when washing a machine damaged by fire. For this reason, never use high-pressure washing equipment.

- Never touch burned components or parts with your bare hands when there is a risk that you may be exposed to contact with melted polymers. First, wash thoroughly with plenty of lime water (a solution or a suspension of calcium hydroxide, i.e. slaked lime).
Use thick, protective gloves made of rubber and wear goggles that are certain to protect your eyes.
- Seek medical attention if your skin may have come in contact with burnt fluor rubber. The skin should be treated with Hydrofluoric Acid Burn Jelly or similar.
Symptoms may not appear until several hours after contact with burnt fluor rubber.
- Discard protective gloves, rags and other items that may have come into contact with burnt fluor rubber.

Document Title: Safety when using lifting equipment	Function Group: 191	Information Type: Service Information	Date: 2015/4/13
Profile: EXC, EC330C L [GB]			

Safety when using lifting equipment

WARNING

Risk of crushing injuries

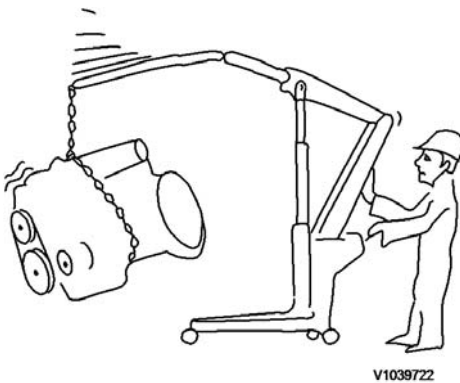

Figure 1

Do not overload lifting or support equipment.

- All lifting devices, e.g., slings, straps, ratchet blocks, etc., must meet governing national regulations for lifting devices.
We will not accept any responsibility if other lifting devices, tools or work methods are used, other than those described in this publication.
- Make sure that the ground surface is flat and has sufficient strength to support the expected load for lifting device with load.
- When lifting or supporting machine parts, use equipment with a lifting capacity that at least equals the weight of the part in question.
- Use the lifting eyes or lifting points that are located on certain machine components.

<https://www.ebooklibonline.com>

Hello dear friend!

Thank you very much for reading.

Enter the link into your browser.

The full manual is available for immediate download.

<https://www.ebooklibonline.com>