

|   |                               |   |                           |
|---|-------------------------------|---|---------------------------|
| Document Title:<br><b>Power transmission, description</b> | Function Group:<br><b>400</b> | Information Type:<br><b>Service Information</b> | Date:<br><b>2015/5/11</b> |
| Profile:<br><b>EXC, EC210C LD [GB]</b>                    |                               |   |                           |

## **Power transmission, description**

The excavator's power transmission is a generic name of all components that transmit motive force to perform the various functions of the excavator. The mechanical power from the engine transmitted via the pump coupling is converted to hydraulic power by the main pumps. Hydraulic power from the main pump goes to the travel motors, slew motor and hydraulic cylinders via the main control valve, where it is converted back to mechanical power, that actuates the travel action, slew action and attachments. The reduction gears of the planetary mechanisms convert the high speed rotation of the hydraulic motor into low speed, high torque rotating force, at the track unit / sprocket for travel, and at the slew unit / ring gear for slewing. The center passage 360° rotating unit allows high pressure hydraulic flow from the main control valve to the track motors. The unit rotates with the superstructure without twisting hoses therefore oil flow is not obstructed by slewing.

|  |                 |   |                           |
|--|-----------------|---|---------------------------|
| Document Title:<br><b>Function description</b> | Function Group: | Information Type:<br><b>Service Information</b> | Date:<br><b>2015/5/11</b> |
| Profile:<br><b>EXC, EC210C LD [GB]</b>         |                 |   |                           |

## Function description

Track gearbox consists of a two stage planetary mechanism that converts the high speed rotation of the hydraulic motor, into low speed, high torque rotating force at the sprocket hub.

See [990 Hydraulic diagram, travel](#).

### Gearbox, torque flow

The power transmitted from the hydraulic motor output shaft is transmitted to the 1st stage sun gear → spline of 1st carrier → 2nd sun gear → 2nd planetary gear → ring gear.

At this time, the reduction ratio of reduction gear is as follows :

### Reduction ratio

1st reduction ratio

$$i_1 = ((Zs1 + Zr) \cdot (Zs2 + Zr) / (Zs1 \cdot Zs2)) - 1$$

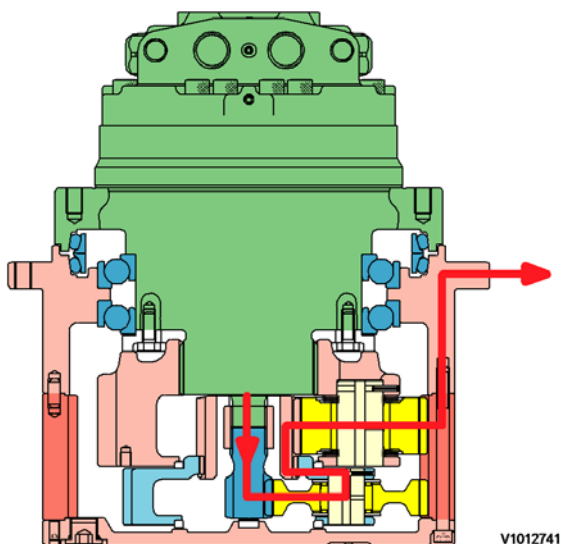

**Figure 1**

### Track gearbox, torque flow

- Zs1 = No. of tooth of 1st sun gear
- Zs2 = No. of tooth of 2nd sun gear
- Zr = No. of tooth of ring gear

|  |                 |   |                           |
|--|-----------------|---|---------------------------|
| Document Title:<br><b>Track gearbox, description</b> | Function Group: | Information Type:<br><b>Service Information</b> | Date:<br><b>2015/5/11</b> |
| Profile:<br><b>EXC, EC210C LD [GB]</b>               |                 |   |                           |

## Track gearbox, description

Track gearbox consists of a two stage planetary mechanism that converts the high speed rotation of the hydraulic motor, into low speed, high torque rotating force at the sprocket hub.

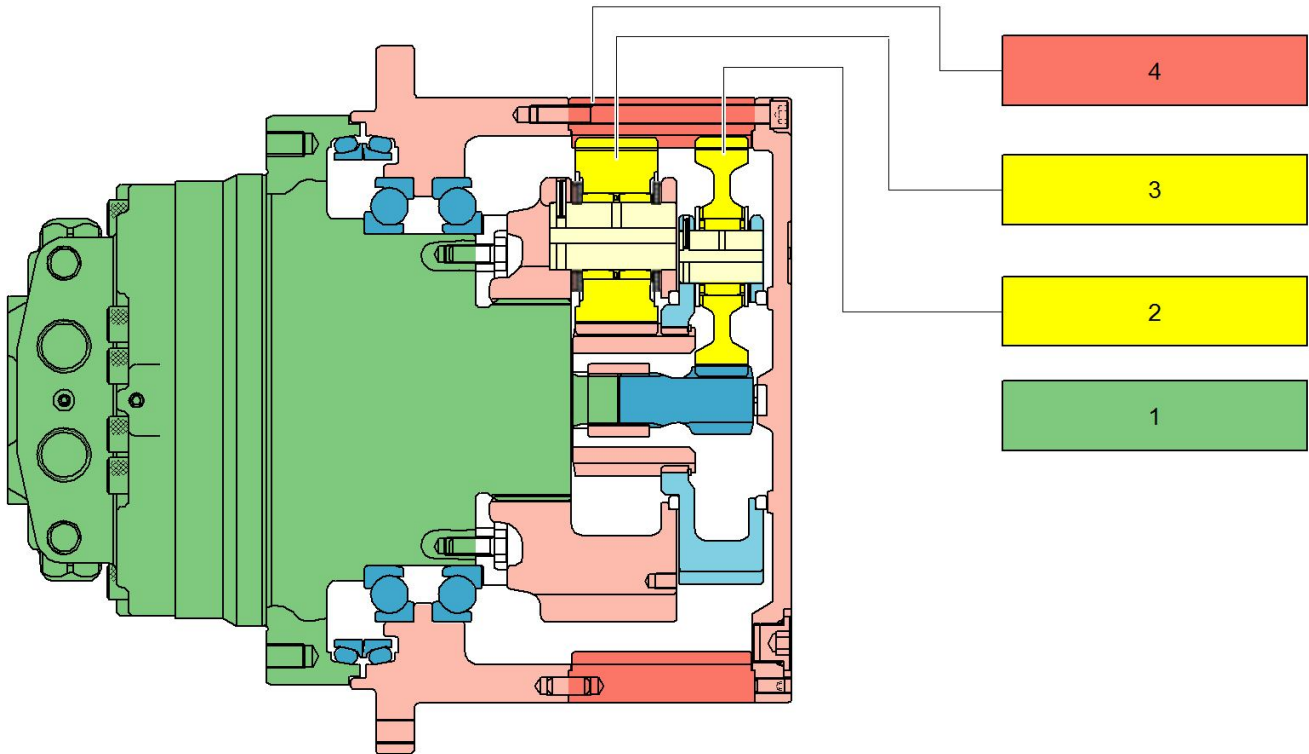

V1012735

**Figure 1**  
**2 stage planetary gearbox**

1. Track motor
2. No.1 planetary gear assembly
3. No.2 planetary gear assembly
4. Ring gear

**<https://www.ebooklibonline.com>**

Hello dear friend!

Thank you very much for reading.

Enter the link into your browser.

The full manual is available for immediate download.

**<https://www.ebooklibonline.com>**

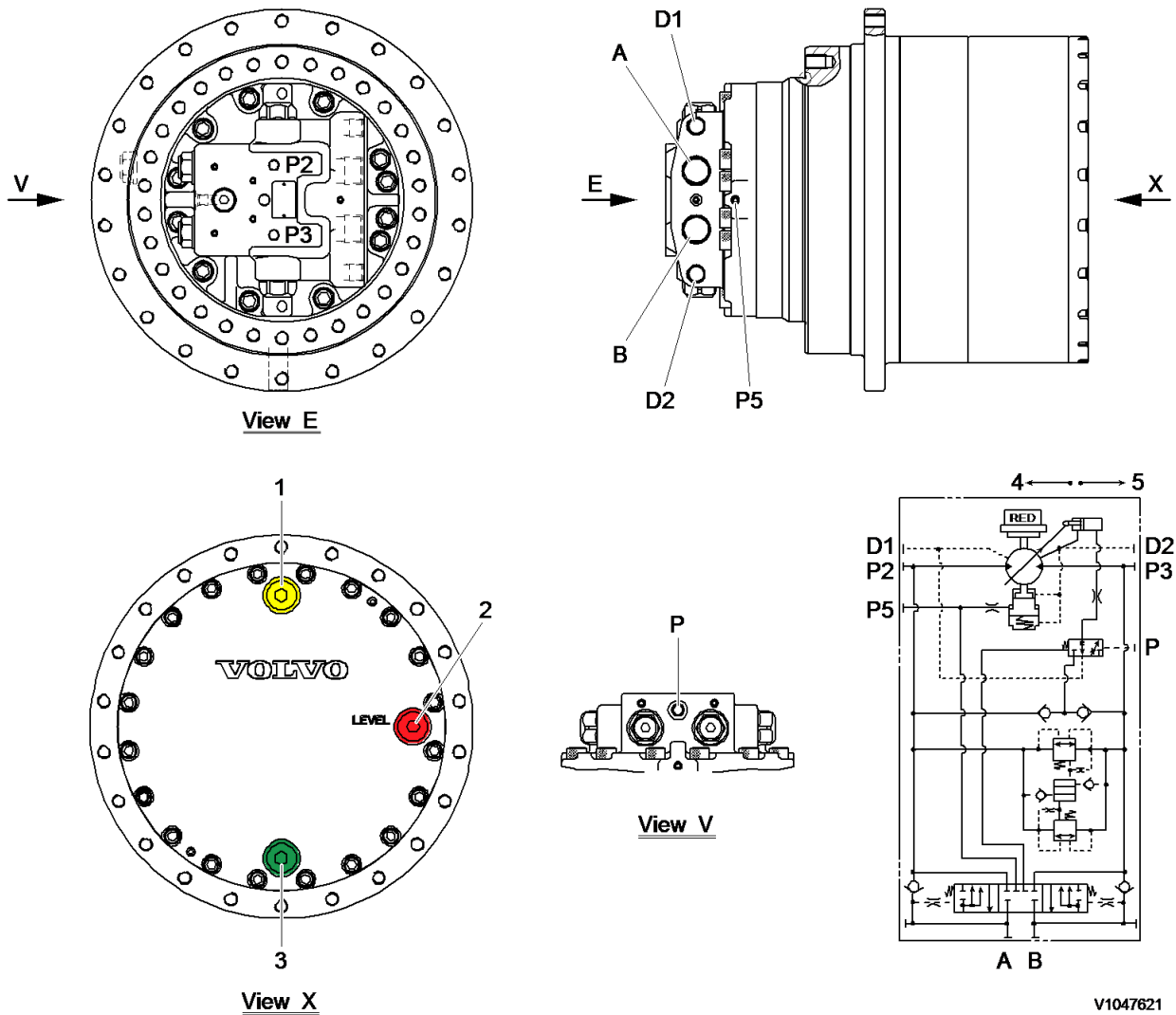

V1047621

**Figure 2**  
**Port connections**

1. Oil filling port (PF 3/4)
2. Oil level check port (PF 3/4)
3. Oil drain port (PF 3/4)
4. High speed
5. Low speed

**Port connections**

| Port symbol | Port size   | Port                                     |
|-------------|-------------|--|
| (A), (B)    | 1-5/16-12UN | Oil supply (Return)                      |
| (P2), (P3)  | PT 1/4      | Pressure check                           |
| (P5)        | PT 1/8      | Brake release pressure                   |
| (P)         | 7/16-20UNF  | Displacement changeover valve oil supply |
| (D1), (D2)  | 3/4-16UNF   | Motor drain                              |

**Rotational direction**

| View from E axis | Inlet | Outlet |
|------------------|-------|--------|
| Clockwise        | A     | B      |
| Counterclockwise | B     | A      |

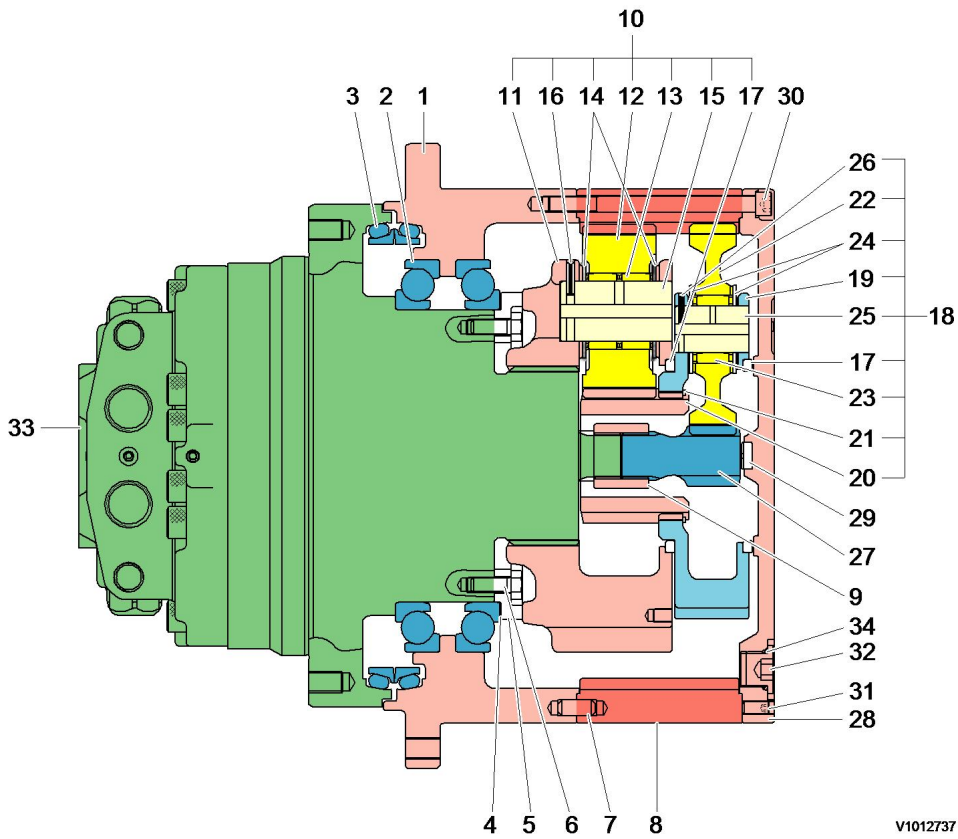

V1012737

**Figure 3**  
**Track gearbox, sectional view**

|    |                              |    |                              |    |               |
|----|------------------------------|----|------------------------------|----|---------------|
| 1  | Housing                      | 13 | No.2 needle bearing          | 25 | No.1 pin      |
| 2  | Angular bearing              | 14 | Thrust washer                | 26 | Spring pin    |
| 3  | Seal                         | 15 | No.2 pin                     | 27 | No.1 sun gear |
| 4  | Shim                         | 16 | Spring pin                   | 28 | Cover         |
| 5  | Retainer                     | 17 | Thrust ring                  | 29 | Pad (thrust)  |
| 6  | Screw                        | 18 | No.1 planetary gear assembly | 30 | Screw         |
| 7  | Parallel pin                 | 19 | No.1 carrier                 | 31 | Screw         |
| 8  | Ring gear                    | 20 | No.2 sun gear                | 32 | Plug          |
| 9  | Coupling                     | 21 | Retaining ring gear          | 33 | Name plate    |
| 10 | No.2 planetary gear assembly | 22 | No.1 planetary gear          | 34 | O-ring        |
| 11 | No.2 carrier                 | 23 | No.1 needle bearing          |    |               |
| 12 | No.2 planetary gear          | 24 | Thrust washer                |    |               |

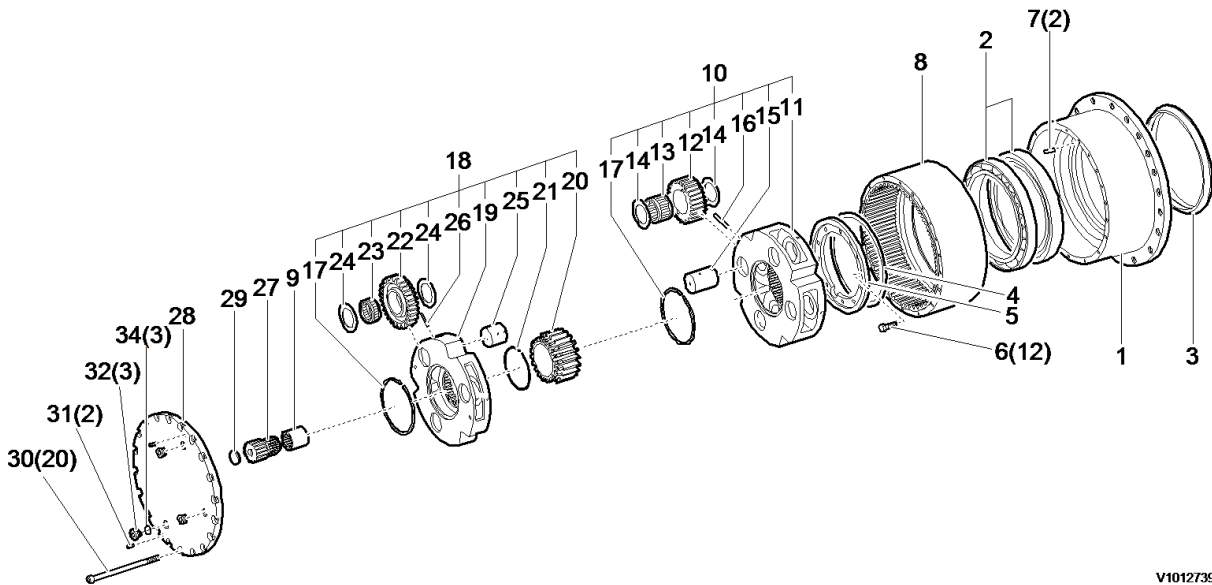

V1012739

**Figure 4**  
**Track gearbox, exploded view**

The power transmitted from the hydraulic motor output shaft is transmitted to the 1st stage sun gear (27) → spline of 1st carrier (19) → 2nd sun gear (20) → 2nd planetary gear (12) → ring gear (8).

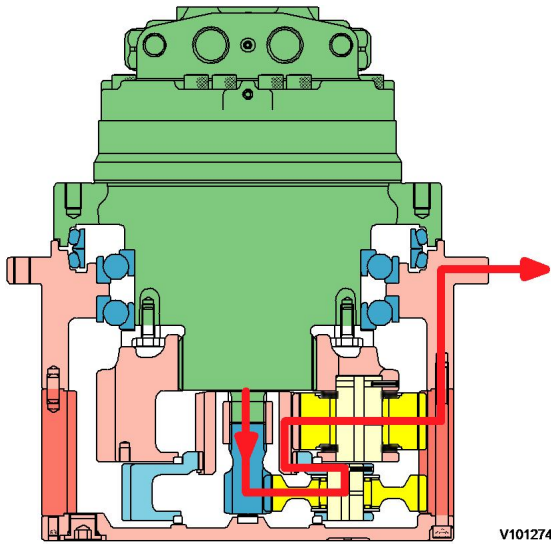

V1012741

**Figure 5**  
**Track gearbox, torque flow**

At this time, the reduction ratio of reduction gear is as follows:

**(1) 1st reduction ratio**

$$i_1 = ((Zs1 + Zr) \cdot (Zs2 + Zr) / (Zs1 \cdot Zs2)) - 1$$

- Zs1 = No. of tooth of 1st sun gear
- Zs2 = No. of tooth of 2nd sun gear
- Zr = No. of tooth of ring gear

|  |                 |   |                           |
|--|-----------------|---|---------------------------|
| Document Title:<br><b>Track gearbox, troubleshooting</b> | Function Group: | Information Type:<br><b>Service Information</b> | Date:<br><b>2015/5/11</b> |
| Profile:<br><b>EXC, EC210C LD [GB]</b>                   |                 |   |                           |

## Track gearbox, troubleshooting

### Track gearbox, troubleshooting

|   |                                   |                              |
|---|-----------------------------------|------------------------------|
| Gearbox does not rotate.                | Motor overloaded.                 | Reduce the load.             |
|   | Gearbox is damaged.               | Replace the gearbox.         |
| Oil leakage from mating joint surfaces. | Liquid gasket improperly applied. | Disassembly and re-apply.    |
|   | Mating surface damaged.           | Repair or replace.           |
|   | Loosen screws.                    | Tighten to specified torque. |
|   | Loosen plug.                      | Tighten to specified torque. |
| Casing leakage.                         | Cracks or pin holes.              | Replace the housing.         |
|   | Cover damaged.                    | Replace the cover.           |

### Track gearbox, troubleshooting

|                                 |                        |                                     |
|---------------------------------|------------------------|-------------------------------------|
| Floating seal leakage.          | Sliding surface worn.  | Replace the floating seal assembly. |
|                                 | O-ring distorted.      |                                     |
| Abnormal operating temperature. | Insufficient gear oil. | Refill to specified level.          |



|   |                 |   |                           |
|---|-----------------|---|---------------------------|
| Document Title:<br><b>Track gearbox, maintenance standard</b> | Function Group: | Information Type:<br><b>Service Information</b> | Date:<br><b>2015/5/11</b> |
| Profile:<br><b>EXC, EC210C LD [GB]</b>                        |                 |   |                           |

## Track gearbox, maintenance standard

### Track gearbox, maintenance standard

The parts are precision finished and must be handled carefully.

Keep the parts of the planetary carrier (s) together, do not mix the bearings, gears, pins and thrust washers.

#### Seals

Replace the seals and O-rings, although they appear not damaged.

#### Part replacement criteria

Replace all parts that appear damaged or are not within the allowable value.

Replace some parts in sets, i.e. gears, bearings, pins and thrust washers.

#### Remove air in the track motor before operating.

1. Check that the gearbox axis is horizontal. Rotate the gearbox housing until the drain plug is on the bottom of the vertical axis of the end cover.  
The gearbox is supplied with oil plugs (draining, filling and level) equipped with an hole that allows the air to bleed.  
**NOTE!**  
Remove the oil plugs with care. When the gearbox is warm, the air inside can be pressurized and this can cause their strongly expulsion towards the worker.
2. Loosen with caution the plugs (2~3 rounds) counterclockwise.
3. Clean the plug to be sure that the air bleed hole is not obstructed.
4. Wait a few seconds to allow the pressurized air to bleed from the gearbox.
5. Remove the plugs and let the oil flow in a large enough container; in order to facilitate the draining must be oil still warm.
6. Wait a few minutes until all the oil is drained and then proceed to screw on the plugs.
7. Proceed with the oil fill-up following the procedures given.

#### NOTE!

Never mix mineral oils with synthetic oils and vice versa.

Do not dispose of the oil in the natural environment but be careful to eliminate it in compliance with the relative rules and regulations that govern locally.

Tightening torque plug. See track gearbox, description.

#### Part replacement criteria

| No. | Part                | Condition  | Allowable value      |
|-----|---------------------|--|----------------------|
| 8   | Ring gear           | The tooth surface is pitted or non uniformly worn.<br>The gear is cracked. | Area rate: within 5% |
| 12  | No.2 planetary gear |  |                      |
| 20  | No.2 sun gear       |  |                      |
| 22  | No.1 planetary gear |  |                      |
| 27  | No.1 sun gear       |  |                      |
| 23  | Needle bearing      | Fitting/flaking of the balls, rollers or races.                            |                      |

|          |                                   |   |  |
|----------|-----------------------------------|---|--|
| 13<br>2  | Needle bearing<br>Angular bearing | Does not rotate smoothly by hand.                               |  |
| 3        | Seal                              | Rust or damage on sliding face.<br>O-ring distorted or damaged. |  |
| 15<br>25 | No.2 pin<br>No.1 pin              | The pin is cracked, galled or pitted.                           |  |
| 24<br>14 | Thrust washer                     | Excessively worn on the face area.                              |  |

### General tools

#### General tools

| No. | Item                              | Size   | Quantity |
|-----|-----------------------------------|--|----------|
| 1   | Socket wrench                     | 19 mm (0.75 inch)  | 1        |
| 2   | L wrench                          | 5 mm (0.2 inch)<br>10 mm (0.39 inch)<br>12 mm (0.47 inch)                      | 1        |
| 3   | Torque wrench                     | 39 ~ 177 Nm (29 ~ 130 lbf ft)  | 1        |
| 4   | Eye bolt                          | PF 3/4<br>M10<br>M12   | 2        |
| 5   | Plastic hammer                    | Approximately L = 300 ~ 500 mm (11.8 ~ 19.7 inch)                              | 1        |
| 6   | Screwdriver                       | Approximately L = 200 mm (7.9 inch)  | 1        |
| 7   | Depth gauge<br>(Vernier calliper) | Range approximately 300 mm (11.8 inch)<br>Minimum scale 0.01 mm (0.00039 inch) | 1        |

### Track gearbox, precautions for operation

#### Installation

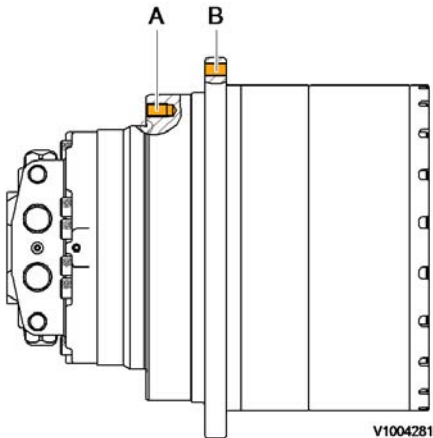

**Figure 2**

#### Mounting location

- A. Main body mounted area
- B. Sprocket mounted area

- Check that the mating mount surfaces are clean.
- Check that the motor is positioned correctly in the frame.
- If the gearbox to frame fit is tight, draw the assembly into the frame evenly with the mounting screws.
- Tighten the screws in a crisscross pattern in several stages to the specified torque.
- Apply these same precautions when mounting the sprocket.

#### Tightening torque

#### Tightening torque

| Item                | Quantity | Thread size | Tightening torque             |
|---------------------|----------|-------------|-------------------------------|
| Reduction screw (A) | 30       | M16 (P2.0)  | 265 ±29.4 Nm (195 ±22 lbf ft) |
| Sprocket screw (B)  | 22       | M16 (P2.0)  | 265 ±29.4 Nm (195 ±22 lbf ft) |

**NOTE!**

The screws must be 10.9 KS strength classification or above.

**Lubricating oil**

**NOTICE**

**Prior to operating the travel function, fill the gearbox with the specified oil to the correct level.**

**NOTE!**

Gear oil specification

Use a gear oil equivalent to API classification GL-4 or GL-5, SAE 90.

**Gear oil replacement period**

- First (initial) oil replacement: 500 operating hours
- Subsequent oil replacement: 2000 operating hours
- After maintenance (initial): 250 operating hours

**NOTE!**

Regardless of the operating hours the gear oil must be replaced at least once per year.

**NOTE!**

Do not mix different types, classifications or brands of oil.

**NOTE!**

Drain the gear oil while it is still warm to flush out any contaminants.

**Gear oil replacement procedure**

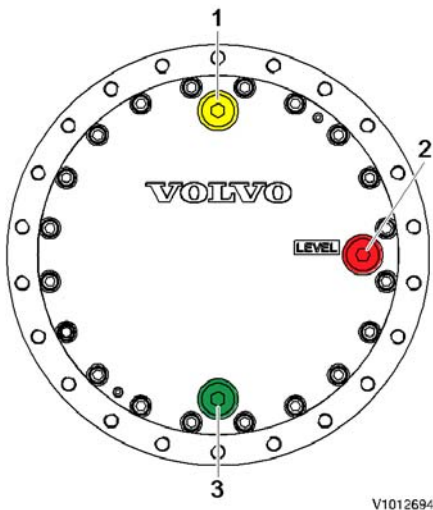

**Figure 3**  
**Oil replacement location**

1. Fill port
  2. Level check port
  3. Drain port
- Rotate the gearbox until the drain plug and the fill plug are on the vertical axis.
  - Remove the 3 plugs in the end cover and drain the oil into a suitable container.
  - Ensure that the drain plug O-ring is not damaged, then install the plug and torque to specification.
  - Refill the gearbox through the fill port until oil exits from the level check port.

- Ensure that the O-ring on each plug is not damaged, then install the plugs and torque to specification.

**NOTE!**

Oil capacity: see [4311 Track gearbox, specifications](#).

**Operating checks**

- Check the oil level prior to operating the travel function.
- Check for oil leakage on the gearbox assembly.
- Check for loose mounting screws.
- Check for abnormal sound or vibration while rotating.
- Check for any abnormal temperature increase after operating for a short time.



**The temperature of the case is high just after running. Use a thermometer to measure. Do not touch directly by hand to prevent a burn injury.**

**NOTE!**

The temperature of the case must be lower than 90 °C, during continuous operation.

|   |                 |   |                           |
|---|-----------------|---|---------------------------|
| Document Title:<br><b>Track unit, replacing</b> | Function Group: | Information Type:<br><b>Service Information</b> | Date:<br><b>2015/5/11</b> |
| Profile:<br><b>EXC, EC210C LD [GB]</b>          |                 |   |                           |

## Track unit, replacing

### Op nbr 431-127

1. Park the machine in the service position F, see [091 Service positions](#).
2.
  - When the engine is running, the hydraulic line is under high pressure. Stop the engine, and remove the residual pressure inside the hydraulic line by operating the control lever smoothly for 3 ~ 4 times with ignition switch at "ON" position.
  - Remove the residual pressure inside the hydraulic tank by pressing the air breather on the hydraulic tank.
  - After disconnecting the hose, install a plug to prevent oil leakage and contamination.
3. Remove the track shoes over the master pin and remove the pin to split the track chain. Insert a bar into the track link to guide the track assembly. Rotate the track backward to remove the track chain from the drive sprocket. See [7753 Track chain assembly, removing](#) to remove the master pin and the track chain.
4. Raise sprocket (4) and insert block (3) between track frame (2) and link (1) to support the undercarriage.

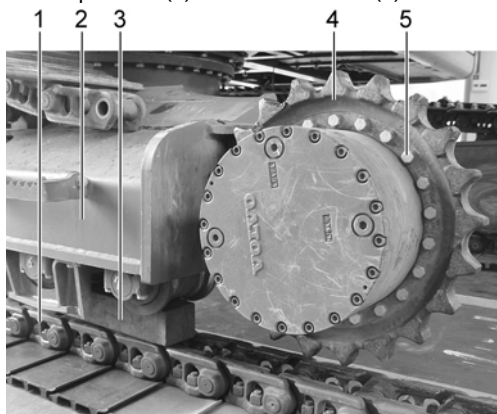

V1045663

**Figure 1**  
**Removal, sprocket**

1. Track link
  2. Track frame
  3. Wood block
  4. Sprocket
  5. Screws
5. Remove screws (5) rotating sprocket (4) and remove sprocket (4) carefully.
  6. Remove screws (1) and motor cover (2).

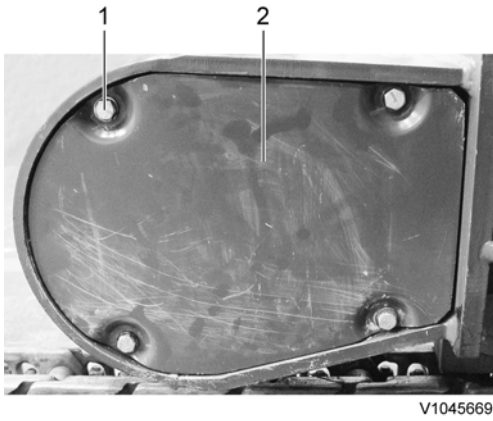

**Figure 2**  
**Removal, motor cover**

1. Screws
2. Motor cover

7. Remove track motor high pressure hoses (1).

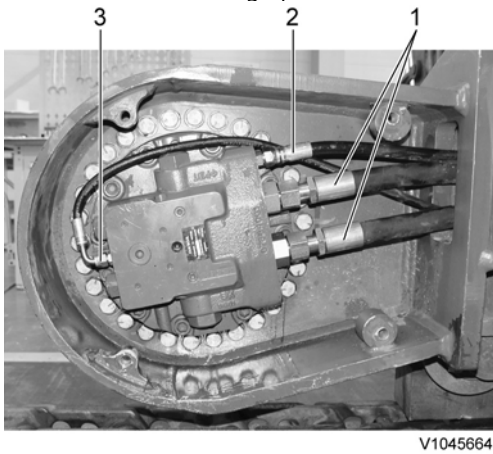

**Figure 3**  
**Removal, hoses**

1. High pressure hoses
2. Drain hose
3. 2nd speed hose

8. Remove track motor drain hose (2).

9. Remove track motor 2nd speed hose (3).

10. Remove fittings (1).

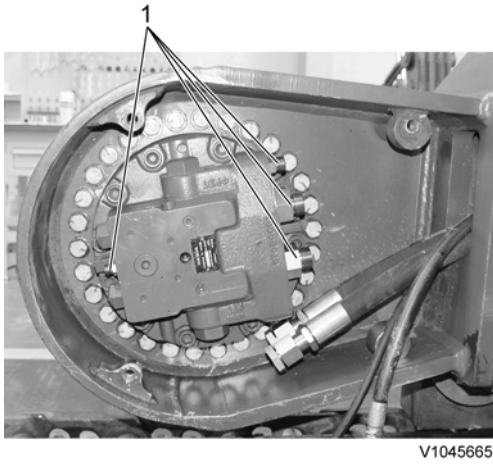

V1045665

**Figure 4**  
**Removal, fittings**

1. Fittings

11. Hold the track unit with hoist (1) and remove mounting screws (2) of the track unit from track frame (3).

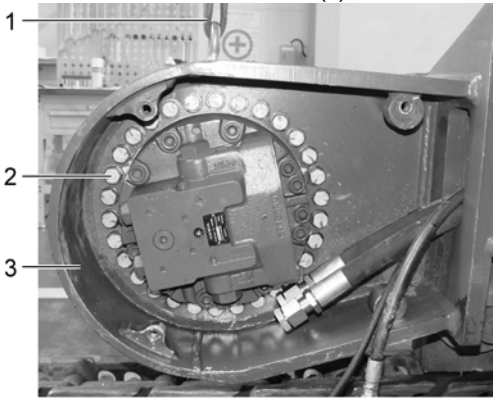

V1045666

**Figure 5**  
**Removal, mounting screws**

1. Hoist
2. Screws
3. Track frame

12. Lift track unit (2) with hoist (1), and lower to the workbench safely.

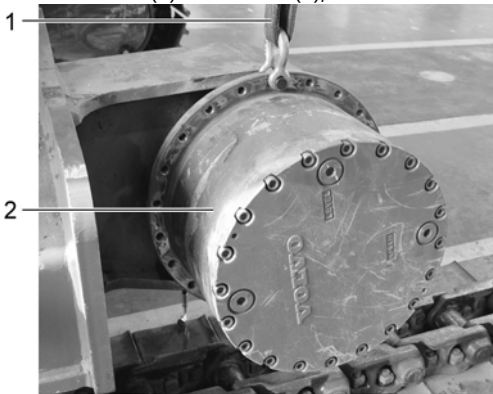

V1045667

**Figure 6**  
**Removal, track unit**

1. Hoist

2. Track unit

13. Install a new track unit in reverse order of the removal procedure.
14. Lift the track chain onto the drive sprocket, insert a bar into the track link to guide the track assembly. Rotate the track forward until the master pin link is at the idler. Install the master pin and the track shoes.  
See [7753 Track chain assembly, installing](#) to install the master pin and the track chain.

|  |                 |   |                           |
|--|-----------------|---|---------------------------|
| Document Title:<br><b>Track gearbox, replacing cover</b> | Function Group: | Information Type:<br><b>Service Information</b> | Date:<br><b>2015/5/11</b> |
| Profile:<br><b>EXC, EC210C LD [GB]</b>                   |                 |   |                           |

## Track gearbox, replacing cover

### Op nbr 431-117

1. Park the machine in the service position B, see [091 Service positions](#).  
Rotate the gearbox until the drain plug and fill plug are on the vertical axis.
2. Remove the 3 plugs on the cover and drain the oil into a suitable container.

**NOTE!**

Oil capacity: 5.8 liters (1.5 US gal)



V1045698

**Figure 1**  
**Removal, plugs**

1. Fill port
2. Level check port
3. Drain port

3. Remove gearbox cover screws (1).

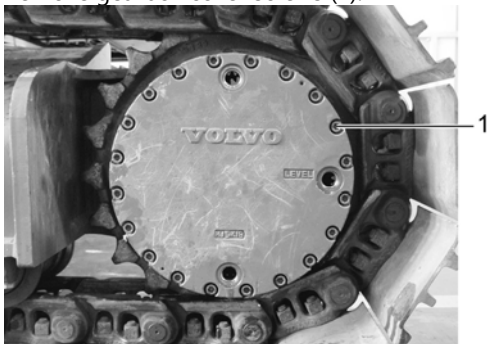

V1045779

**Figure 2**  
**Removal, screws**

1. Screw

4. Thread two screws (2) into gearbox (3) to hold fall cover (4).

Tighten two set-screws (1) to separate cover (4) from track gearbox (3).

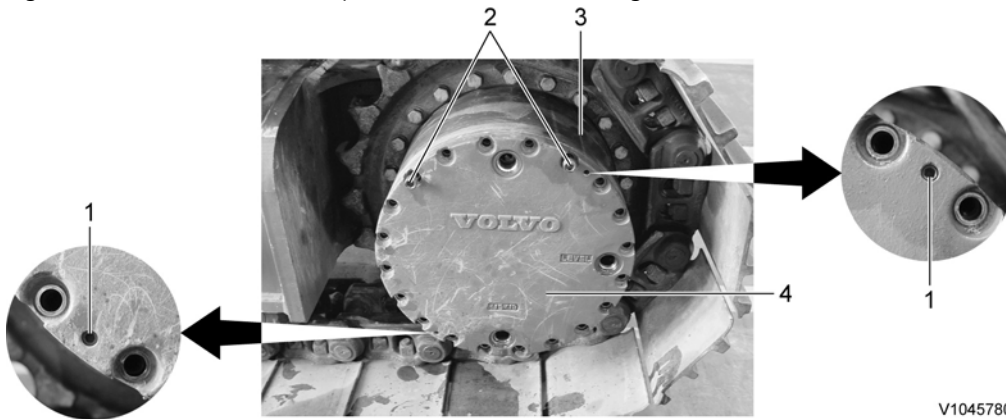

V1045780

**Figure 3**  
**Removal, gearbox cover**

1. Set-screw
2. Screw
3. Track gearbox
4. Track gearbox cover

5. Remove gearbox cover (4) from track gearbox (3).

**NOTE!**

Thoroughly clean the mounting surface.

6. Install the two set-screws to a new gearbox cover.

7. Install the new gearbox cover to the track gearbox.

**NOTE!**

Before replacing cover (1), apply sealing compound (2) to the mounting surface.

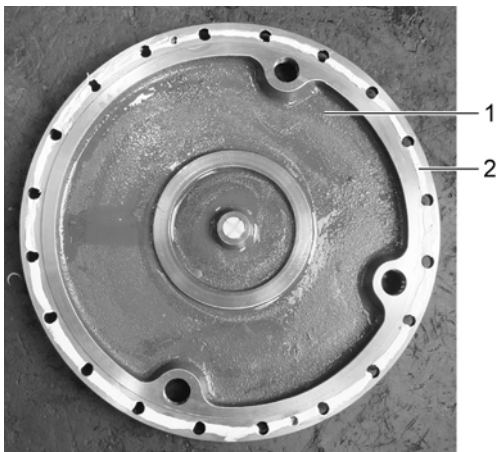

V1045781

**Figure 4**  
**Applying, sealing compound**

1. Track gearbox cover
2. Sealing compound

8. Install drain plug (1) and tighten it to the specified torque.

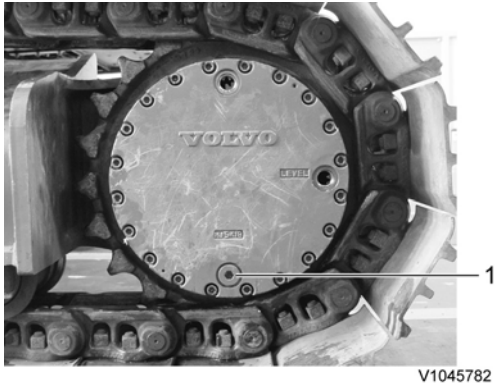

V1045782

**Figure 5**  
**Installation, drain plug**

1. Drain plug
9. Fill the oil through the fill port until oil exits from the level check port.
10. Install the fill and level check plug and tighten them to the specified torque.

|  |                 |   |                           |
|--|-----------------|---|---------------------------|
| Document Title:<br><b>Track gearbox (removed),<br/>replacing floating seal</b> | Function Group: | Information Type:<br><b>Service Information</b> | Date:<br><b>2015/5/11</b> |
| Profile:<br><b>EXC, EC210C LD [GB]</b>   |                 |   |                           |

## Track gearbox (removed), replacing floating seal

Op nbr 431-115

[14633157 Drift](#)

[14599552 Measuring plate](#)

1. Remove the 3 plugs on the cover and drain the oil into a suitable container.

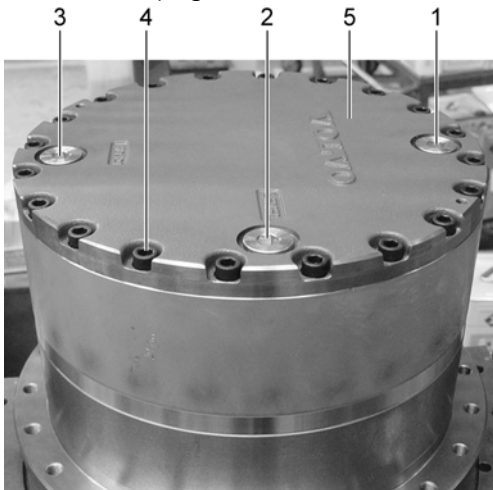

V1049959

**Figure 1**  
**Removal, cover**

1. Fill port
2. Level check port
3. Drain port
4. Screw
5. Cover

**NOTE!**

Oil capacity. See [4311 Track gearbox, specifications](#).

2. Remove the screws and cover.
3. Remove the No.1 planetary gear assembly.



**Suggest:**

**For more complete manuals. Please go to the home page.**

**<https://www.ebooklibonline.com>**

**If the above button click is invalid. Please download this document first, and then click the above link to download the complete manual.**

**Thank you so much for reading**

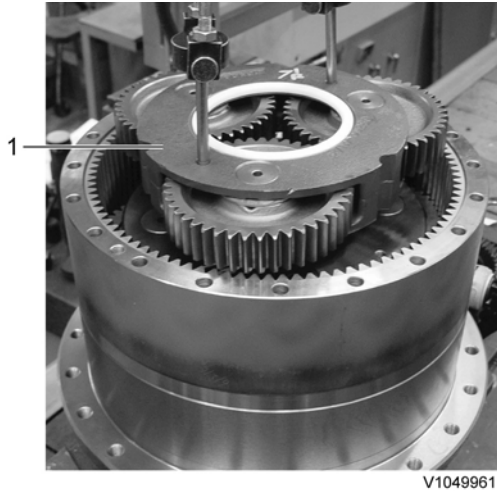

**Figure 2**  
**Removal, No. 1 planetary gear assembly (1)**

4. Remove the No.1 sun gear and coupling.



**Figure 3**  
**Removal, No.1 sun gear (1) and coupling (2)**

5. Screw the eye bolts into ring gear, and remove ring gear using a plastic hammer.

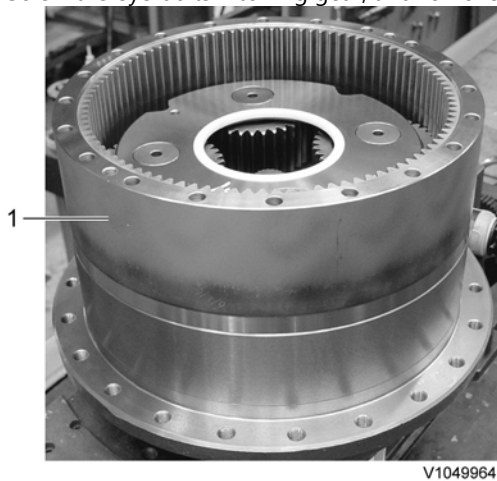

**Figure 4**  
**Removal, ring gear (1)**

6. Remove the No.2 planetary gear assembly.

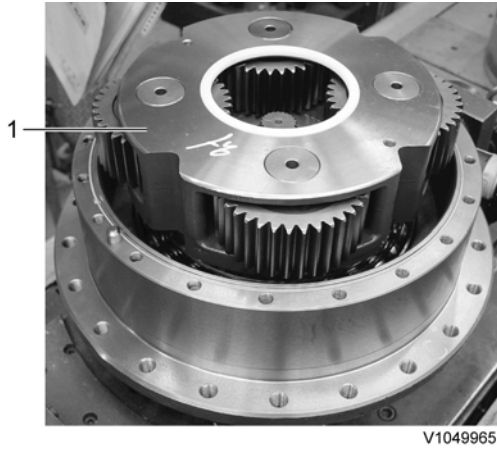

V1049965

**Figure 5**  
**Removal, No.2 planetary gear assembly (1)**

7. Remove the screws, retainer and the shim.



V1049967

**Figure 6**  
**Removal, retainer**

1. Screws
2. Retainer

8. Screw the eye bolts into housing, and then remove housing.

**NOTE!**

When difficult to remove, lift the body vertically and tap lightly with a plastic hammer.



**WARNING**

**The parts are heavy. Take appropriate safety precautions.**

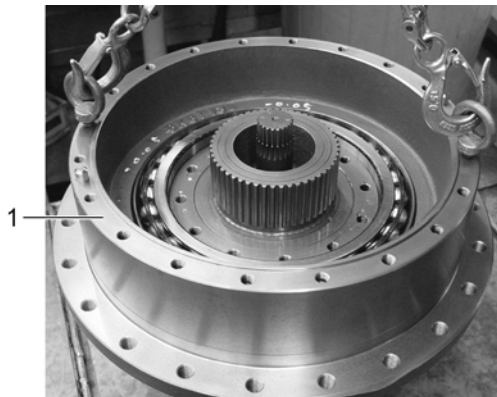

V1049968

**Figure 7**

**<https://www.ebooklibonline.com>**

Hello dear friend!

Thank you very much for reading.

Enter the link into your browser.

The full manual is available for immediate download.

**<https://www.ebooklibonline.com>**