

Document Title: Frame and track unit, specifications	Function Group: 700	Information Type: Service Information	Date: 2015/10/28
Profile:			

Frame and track unit, specifications

Specifications

Item	Unit	EC140LC	EC140LCM	
Length of undercarriage	mm (ft)	3740 (12' 3")	3790 (12' 5")	
Track link pitch	mm (in)	171.45 (6.75)	190 (7.48)	
No. of links	EA	46	42	
No. of top roller	EA	1 × 2	2 × 2	
No. of bottom roller	EA	7 × 2	6 × 2	
Recoil spring	Type	–	Hydraulic adjuster (grease) Hydraulic adjuster (grease)	
	Spring, set length	mm (in)	405 (15.9)	405 (15.9)
	Set load	kg (lb)	8560 ± 685 (18872 ± 1510)	8560 ± 685 (18872 ± 1510)
	Adjust	mm (in)	–20 ~ +115 (–0.79 ~ +4.53)	–20 ~ +115 (–0.79 ~ +4.53)
Sprocket	No. of tooth	EA	21 EA	21 EA
	Pitch circle diameter	mm (in)	644.6 (25.3)	644.6 (25.3)
No. of shoes	–	92	84	
Ground contact pressure with standard digging unit (boom, arm and bucket)	500 mm width (Triple grouser)	kgf / cm2 (psi)	0.40 (5.68)	–
	600 mm width (Triple grouser)		0.34 (4.84)	0.36 (5.12)
	700 mm width (Triple grouser)		0.30 (4.27)	0.32 (4.56)
	750 mm width (Triple grouser)		0.28(3.98)	–
	800 mm width (Triple grouser)		–	0.28 (3.98)
	900 mm width (Triple grouser)		–	0.25 (3.56)

Document Title: Superstructure, installation	Function Group: 710	Information Type: Service Information	Date: 2015/10/28
Profile:			

Superstructure, installation

1. Bundle the hoses attached to the center passage together and place them upright.
2. Coat the screws and threaded holes of the slew ring with "Three bond 1215" (Loctite #515).

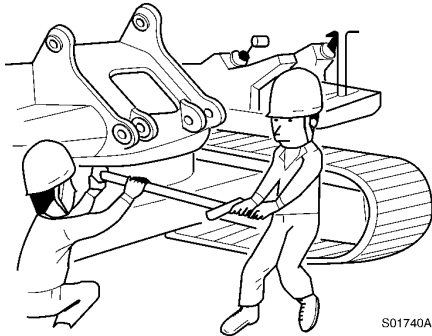

Figure 1

Fig. 5 Installing the superstructure

3. Lift the superstructure and install it to the slew ring.

NOTE!

Lower the superstructure so that the slew pinion and the slew ring are engaged.

NOTE!

For tightening torque, refer to the torque chart.

NOTE!

Tighten diagonally opposite screws in sequence.

4. Connect the hoses, center passage clamping screw and seal cover disconnected for removal.

Document Title: Superstructure, removal	Function Group: 710	Information Type: Service Information	Date: 2015/10/28
Profile:			

Superstructure, removal

! WARNING

The superstructure weigh approximately 4 ~ 7 tons (excluding counterweight and digging units). Pay attention to safe footing and the area around the crane before proceeding to remove or install the superstructure.

1. Remove the digging unit.
2. Disconnect center passage clamping screw, seal cover, hydraulic oil hoses, drain hose, and one servo hydraulic oil hose from center passage.

NOTE!

Bundle the hoses. Blind plug each disconnected hose and pipe.

3. Remove screws (A) fixing the outer race of the slew ring.

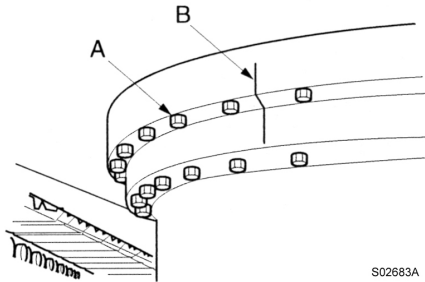

Figure 1
Slew ring installed

B. Confirm alignment of match-marks

4. Dismantle the cab, counterweight and guard. Place a wire rope on the superstructure and lift it with a crane to an extent that the wire rope is not slack.

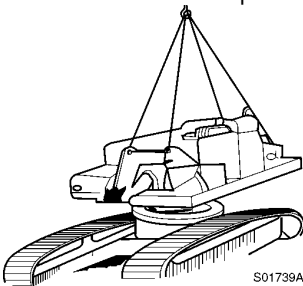

Figure 2
Lifting the superstructure

5. Lift the superstructure just a little, and after confirming safety all around, lift it up and out.

<https://www.ebooklibonline.com>

Hello dear friend!

Thank you very much for reading.

Enter the link into your browser.

The full manual is available for immediate download.

<https://www.ebooklibonline.com>

Document Title: Additional counterweight & digging unit	Function Group: 716	Information Type: Service Information	Date: 2015/10/28
Profile:			

Additional counterweight & digging unit

When special digging units (such as: scrap handling clam, log loader etc.,) are installed on the excavators, an additional counterweight is required for stability.

In these cases, check the digging unit specification and compare it carefully to the excavator load lifting capacity chart.

And if in doubt, contact your local dealer for advice.

Additional counterweight can be installed according to special digging units, however we are not responsible for any failure of the excavator or breakage of digging units due to such application.

For reference, an excavator is basically designed only for excavating and is not designed to be used as a crane.

Document Title: Undercarriage, description	Function Group: 7181	Information Type: Service Information	Date: 2015/10/28
Profile:			

Undercarriage, description

Undercarriage consists of idlers, spring package, top and bottom rollers, sprockets, track links, track frame and track guards.

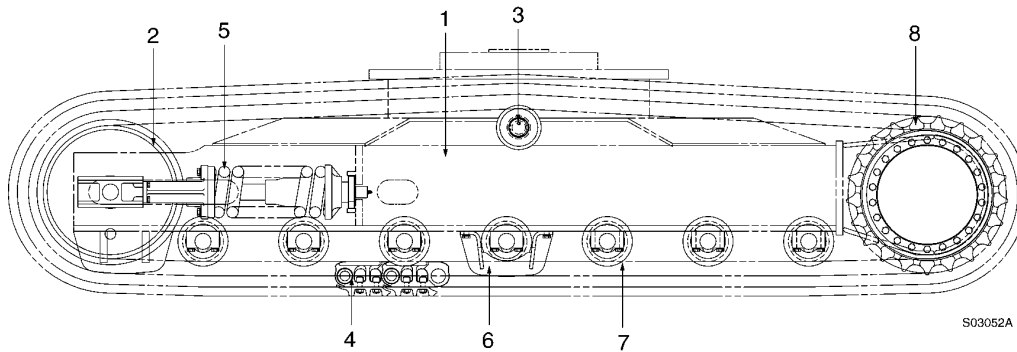

Figure 1
Structure, undercarriage

1	Track frame	3	Top roller	5	Spring package	7	Bottom roller
2	Idler	4	Track link	6	Track guard	8	Sprocket

Document Title: Undercarriage, tightening torque	Function Group: 7181	Information Type: Service Information	Date: 2015/10/28
Profile:			

Undercarriage, tightening torque

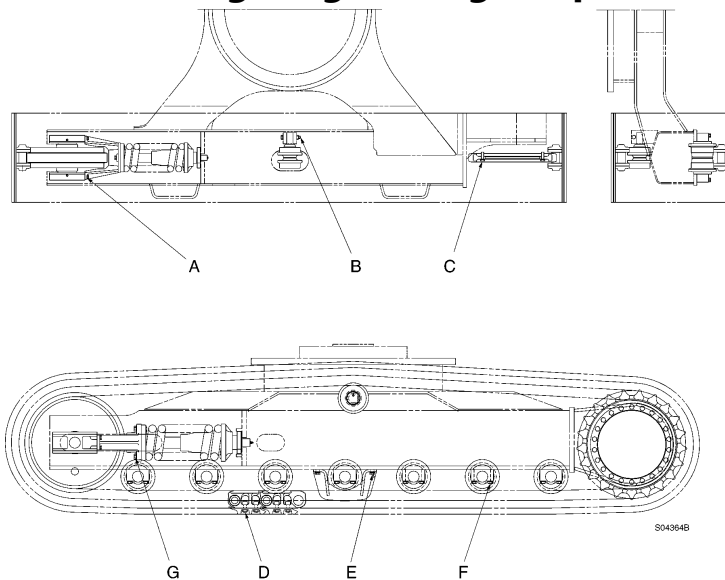

Figure 1
Tightening torque

	EC140LC	EC140LCM
A	11.3 ± 1.1kgf·m (82 ± 8 lbf·ft)	–
B	52 ± 5 kgf·m (375 ± 36 lbf·ft)	52 ± 5 kgf·m (375 ± 36 lbf·ft)
C	28.5 ± 3 kgf·m (206 ± 22 lbf·ft)	28.5 ± 3 kgf·m (206 ± 22 lbf·ft)
D	42 ± 4 kgf·m (303 ± 29 lbf·ft)	58 ± 5 kgf·m (419 ± 36 lbf·ft)
E	28.5 ± 3 kgf·m (206 ± 22 lbf·ft)	28.5 ± 3 kgf·m (206 ± 22 lbf·ft)
F	28.5 ± 3 kgf·m (206 ± 22 lbf·ft)	28.5 ± 3 kgf·m (206 ± 22 lbf·ft)
G	28.5 ± 3 kgf·m (206 ± 22 lbf·ft)	28.5 ± 3 kgf·m (206 ± 22 lbf·ft)

Document Title: Selection of track shoes	Function Group: 775	Information Type: Service Information	Date: 2015/10/28
Profile:			

Selection of track shoes

Choose suitable track shoes to match the ground conditions.

Method of selecting shoes



Confirm the category from the list of uses in the table [Invalid linktarget] , then use the table [Invalid linktarget] to select the shoe.

Categories "B" is wide shoe, so there is restrictions on their use.

Therefore, before using, check the restrictions and consider carefully the conditions of use before selecting a suitable shoe width. If necessary, give the customer guidance in their use.

When selecting the shoe width, select the narrowest possible within the range that will give no problem with flotation and ground pressure. If a wider shoe than necessary is used, there will be a large load on the shoe, and this may lead to bending of the shoe, cracking of the links, breakage of the pins, loosening of the shoe screws, or other problems.

Category, track shoes

Category	Use	Precautions when using
A	Rocky ground, normal soil	Travel in low speed when traveling on rough ground with obstacles such as large boulders and fallen trees.
B	Soft ground	Travel in high speed only on flat ground. When it is impossible to avoid traveling over obstacles, lower the travel speed to approximately half of low speed.  Cannot be used on rough ground where there are large obstacles such as boulders and fallen trees.
C	Extremely soft ground (swamp ground)	Use only for ground where "A" and "B" are impossible to use. Travel in high speed only on flat ground. When it is impossible to avoid traveling over obstacles, lower the travel speed to approximate half of low speed.  Cannot be used on rough ground where there are large obstacles such as boulders and fallen trees.

Selection, track shoes

Specification	EC140LC	EC140LCM
500 mm grouser	A	–
600 mm grouser	A	A
700 mm grouser	B	B
750 mm grouser	B	–
800 mm grouser	–	C
900 mm grouser	–	C

Document Title: Idler, assembly	Function Group: 7751	Information Type: Service Information	Date: 2015/10/28
Profile:			

Idler, assembly

Assemble in the reverse order of disassembly.

- Place bushing (4) on idler wheel (1), and using jig (h), force fit with press (a).

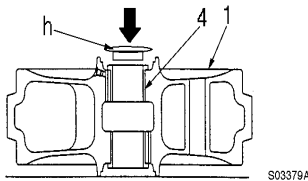

Figure 1
Location to be inspected

- Install o-ring (9) on shaft (2).

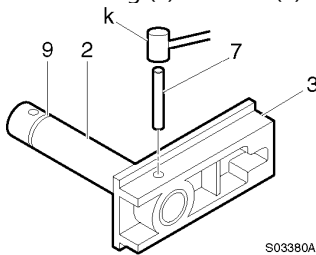

Figure 2
Assembly, o-ring and etc.

- Apply a thin coat of grease to inner side of support (3), install shaft (2), and insert spring pin (7). In this case, take care not to damage o-ring (9).
- Insert seal ring (5) and o-ring (6) to the support (3) and idler wheel (1), respectively.
- Install shaft (2) to idler (1). Lightly coat engine oil on seal ring (5) contact face.

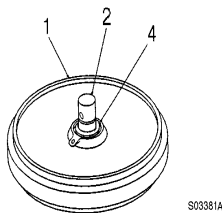

Figure 3
Assembly, shaft

- Install support (3) with seal ring (5) and o-ring (6) to idler wheel (1).
- Insert pin (7) with hammer (k).
- Fill with engine oil (j).

	EC140LC	EC140LCM
Oil capacity	260 cc (15.9 cu·in)	365 cc (16.4 cu·in)

- Install plug (8) with teflon tape (L), and tighten securely.

Inspection after assembly

- Confirm that there are no oil leaks around seals (5, 6) and plug (8).

2. Assemble the idler assembly and track spring. After assembling, manually confirm that idler (1) rotates to the extent you can rotate it despite the resistance. (More than 10 times).

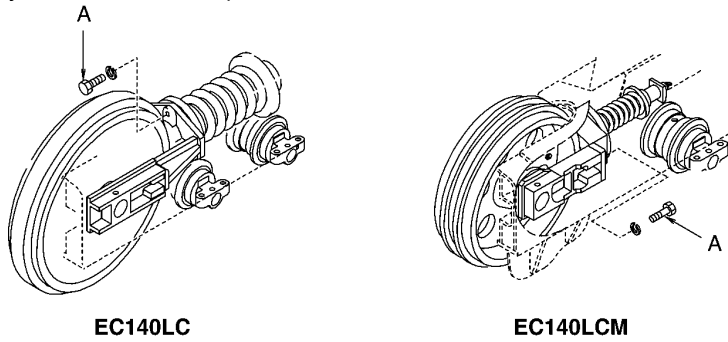

S03389A

Figure 4
Assembly, idler and track spring

- Apply loctite #277 to screw A
 - Tightening torque: $28.5 \pm 3 \text{ kgf}\cdot\text{m}$ ($206 \pm 2 \text{ lbf}\cdot\text{ft}$)
3. Prior to filling with oil perform a pressure leak test. – Attach a pressure regulated air line to the oil fill port, then completely immerse the assembly in water. – Under a pressure of $2 \sim 3 \text{ kgf/cm}^2$ ($28 \sim 43 \text{ psi}$), air bubbles must not form for 15 seconds.
 4. End play must be within 0.1 to 0.6 mm.

Document Title: Idler, description	Function Group: 7751	Information Type: Service Information	Date: 2015/10/28
Profile:			

Idler, description

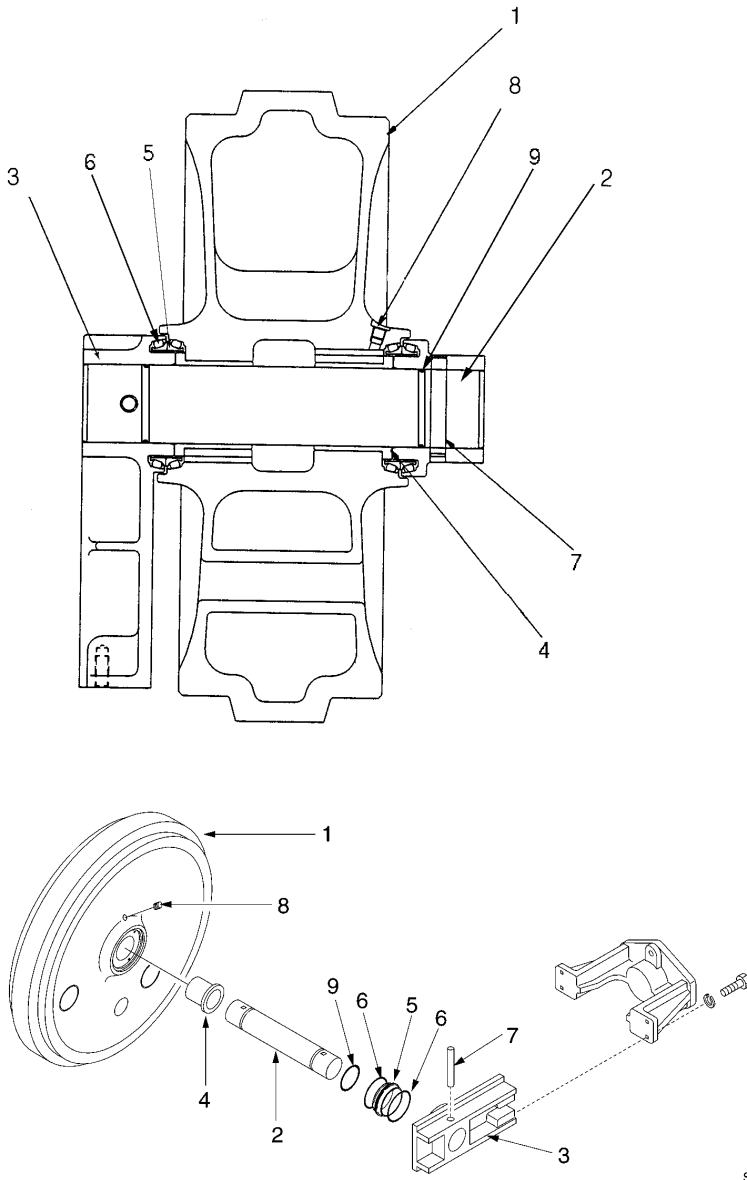

S03368B

Figure 1
Structure, idler

1	Idler wheel	6	O-ring
2	Shaft	7	Pin
3	Support	8	Plug
4	Bushing	9	O-ring (shaft)
5	Seal ring		

Document Title: Idler, disassembly	Function Group: 7751	Information Type: Service Information	Date: 2015/10/28
Profile:			

Idler, disassembly

The numbers in parentheses following each part name in the text correspond to those in figure.

1. Remove the screws, and remove the track spring.

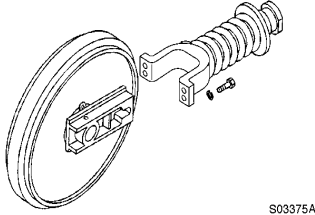

Figure 1
Removal, track spring

2. Remove plug (8) to drain oil.
3. Put pin jig (d) on pin (7), and force out the pin by lightly tapping the jig with a hammer.

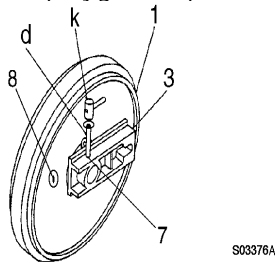

Figure 2
Removal, pin

4. Place idler (1) on idler support jig (f), put shaft removal jig (g) on shaft (2) and force out the shaft using press(a).

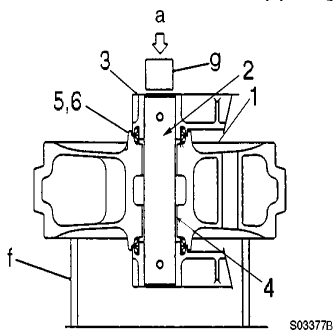

Figure 3
Push with a press

5. Place idler (1) on idler support jig (f), put bearing assembly jig (h) and bushing removal jig (e) on bushing (4), and drive out the bushing by lightly tapping the jig.

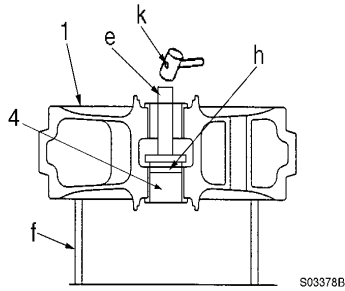

Figure 4

Removal, bushing

6. Remove seal ring (5) and o-ring (6) from idler wheel (1) and support (3), respectively.
7. Remove o-ring (9) from shaft (2).

Inspection after disassembly

1. Confirm that there is no damage or rust on the sealing face of seal (5).
2. Confirm that any wear of idler (1) is within the allowable range.
3. Confirm that any wear of shaft (2) or bushing (4) is within the allowable range.

Document Title: Idler, installation	Function Group: 7751	Information Type: Service Information	Date: 2015/10/28
Profile:			

Idler, installation

Installation of the idler and the track spring

1. Tighten connecting screws (1) of idler and track spring.
2. Pass a wire rope around the track spring bracket, lift the idler assembly, then fit and push the slide block into the slide groove in the track frame.

CAUTION

Confirm that the boss at the piston end of the track spring is in the track frame hole

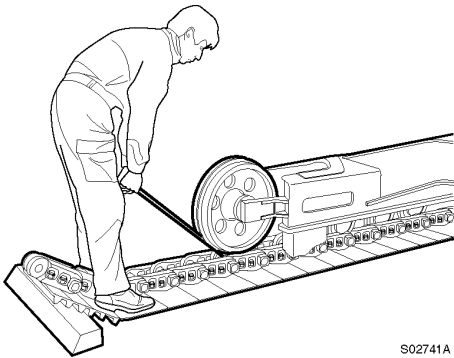

Figure 1
Install, idler assembly

3. Install the track.

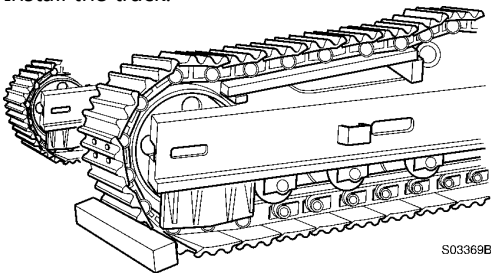

Figure 2
Installation, track

Document Title: Idler, measurement of wear (EC140LC)	Function Group: 7751	Information Type: Service Information	Date: 2015/10/28
Profile:			

Idler, measurement of wear (EC140LC)

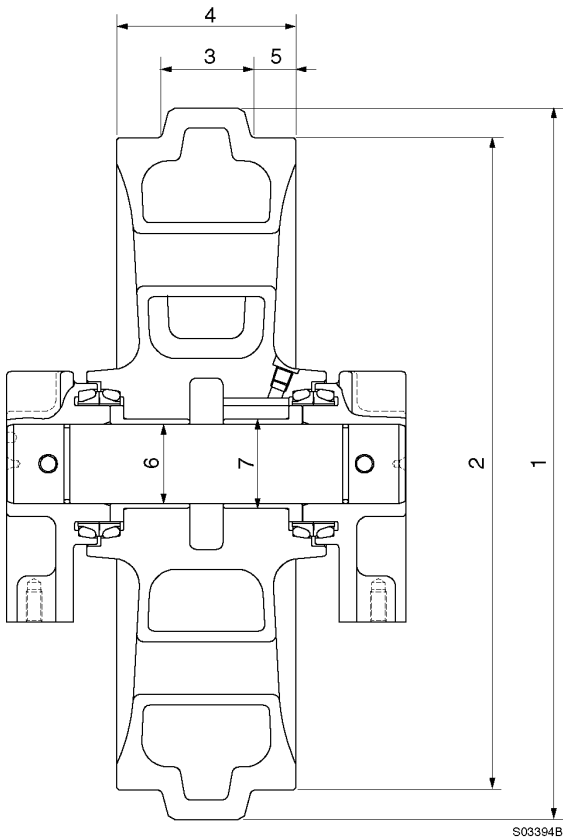

Figure 1
Measurement, wear

Limit of wear (EC140LC), unit: mm (in)

No.	Check item	Standard size	Repair limit		Remedy		
1	Outer diameter of flange	540 (21.3)	-		Reinforcement welding or replace		
2	Outer diameter of tread	495 (19.5)	483 (19.0)				
3	Width of flange	68 (2.7)	60 (2.4)				
4	Total width of tread	135 (5.3)	-				
5	Width of tread	33.5 (1.3)	40 (1.6)				
6	Clearance between shaft and bushing	Standard size	Tolerance		Clearance		Replace bushing
			Shaft	Hole	Standard	Repair limit	
		70	0 -0.03	+0.35 +0.30	0.3 ~0.38	1.5	
7	Clearance between shaft and support	78	+0.132 +0.102	+0.064 0	0.038 ~0.132	-	Replace bushing

Document Title: Idler, removal	Function Group: 7751	Information Type: Service Information	Date: 2015/10/28
Profile:			

Idler, removal

Removal of the idler and the track spring

1. Remove the track.
2. Pass a wire rope around the track spring bracket, lift the idler assembly, and push the bracket out of the track frame using a pry bar.

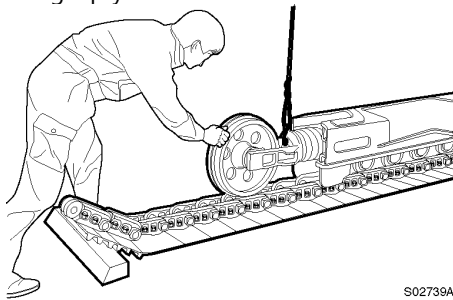

Figure 1
Removal, idler assembly

3. Remove connecting screws (1) of idler and track spring.

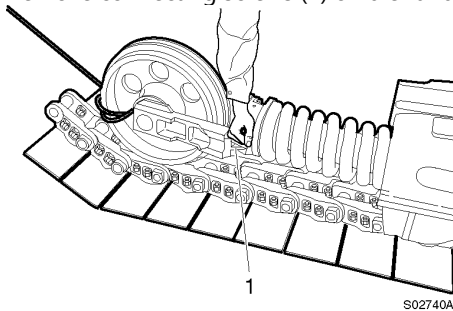

Figure 2
Removal, connecting screw

Document Title: Idler, tools for disassembly and assembly	Function Group: 7751	Information Type: Service Information	Date: 2015/10/28
Profile:			

Idler, tools for disassembly and assembly

Prepare the following tools for disassembly and assembly.

Tools, unit: mm

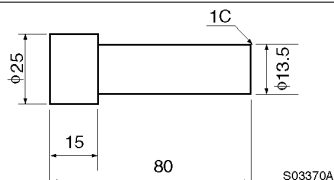
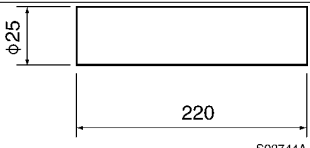
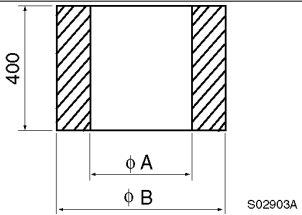
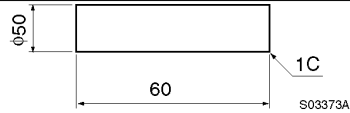
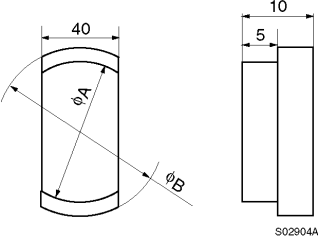
Symbol	Tools	Remark
a	Press	20 ton class (44000 lbs)
b	Grease gun	
c	Torque wrench	60 kgf·m (433 lbf·ft)
d	Pin jig	 <p>S03370A</p>
e	Bushing driver jig	 <p>S02744A</p>
f	Idler support jig	 <p>S02903A</p> <p>φ A: φ 280 (EC140LC), φ 500 (EC140LCM) φ B: φ 300 (EC140LC), φ 520 (EC140LCM)</p>
g	Shaft extruding jig	 <p>S03373A</p>
h	Bushing assembly jig	 <p>S02904A</p> <p>φ A: φ 58 (EC140LC), φ 68 (EC140LCM) φ B: φ 66 (EC140LC), φ 75 (EC140LCM)</p>
j	Engine oil	SAE 10W-30
k	Hammer	
L	Teflon tape	1 Roll

Document Title: Sprocket, installation	Function Group: 7752	Information Type: Service Information	Date: 2015/10/28
Profile:			

Sprocket, installation

The installation procedure is reverse order of removal.

1. Install the sprocket on the track gearbox.
2. Apply loctite #277 to the sprocket screws (C), and tighten them to the specified torque.

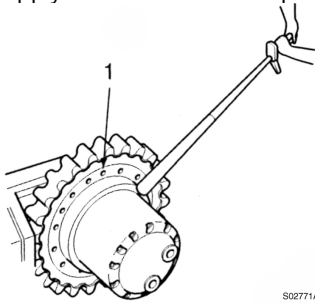

Figure 1
Screw in, screws

- Tightening torque: 28.5 ± 3 kgf·m (266 ± 22 lbf·ft)



Suggest:

For more complete manuals. Please go to the home page.

<https://www.ebooklibonline.com>

If the above button click is invalid. Please download this document first, and then click the above link to download the complete manual.

Thank you so much for reading

Document Title: Sprocket, measurement of wear	Function Group: 7752	Information Type: Service Information	Date: 2015/10/28
Profile:			

Sprocket, measurement of wear

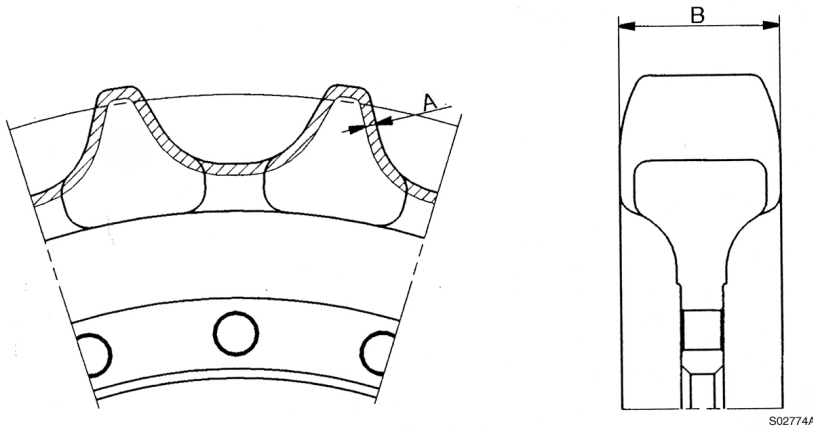

Figure 1
Sprocket

Wear limit, unit: mm (in)

Symbol	Item	EC140LC	EC140LCM	Remedy
A	Wear limit of sprocket tooth profile	6 (0.24)	6 (0.24)	Replace
B	Width of sprocket tooth	Standard value	58 ± 2 (2.28 ± 0.08)	
		Allowable value	50 (1.97)	62 (2.44)
C	Number of teeth	21 EA	21 EA	–

Document Title: Sprocket, removal	Function Group: 7752	Information Type: Service Information	Date: 2015/10/28
Profile:			

Sprocket, removal

1. Remove the track.
2. Place a wooden block (W) on the track, and place the undercarriage on the block to raise the sprocket off the track.
3. Remove the sprocket mounting screw (C), using a socket wrench.

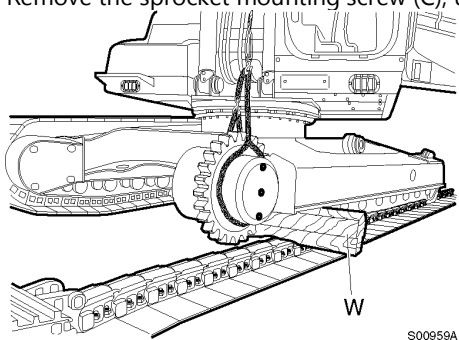

Figure 1
Removal, sprocket

<https://www.ebooklibonline.com>

Hello dear friend!

Thank you very much for reading.

Enter the link into your browser.

The full manual is available for immediate download.

<https://www.ebooklibonline.com>