

Document Title: Frame, description	Function Group: 711	Information Type: Service Information	Date: 2015/11/5
Profile: COA, DD112HF, DD118HF, DD118HA [GB]			

Frame, description

The machine consists of a front and rear frame which are connected by a vertical articulation pin and a horizontal articulation pin. The front frame includes a seat and control console, water tank system and fuel tank. The rear frame includes a water tank system, engine, battery compartment and the hydraulic oil tank.

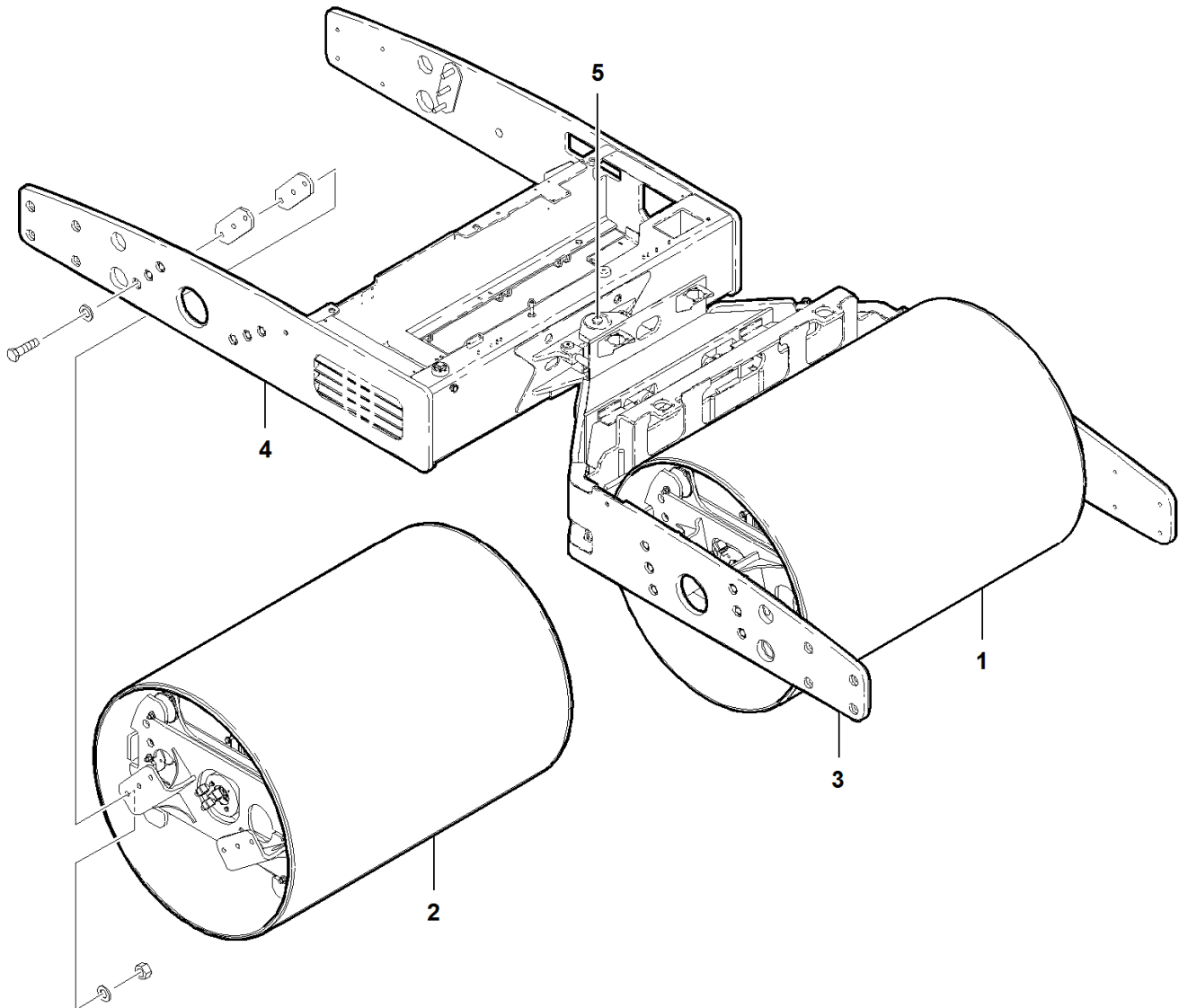

V1066142

Figure 1
Frame and components

1. Drum assembly
2. Drum assembly
3. Front frame
4. Rear frame

5. Articulation pin

Document Title: Drum, description	Function Group: 777	Information Type: Service Information	Date: 2015/11/5
Profile: COA, DD112HF, DD118HF, DD118HA [GB]			

Drum, description

To meet varying job requirements, the operator can manually select individual drum amplitude plus dual drum, front drum or rear drum vibration. The DD112HF is equipped with a high/low amplitude selector switch. The DD118 compactor series of models has 8 amplitude settings which are manually set via an adjusting wheel on each drum.

Vibration is achieved with an eccentric weight that rotates inside each drum. There is a direct 1:1 relationship between the eccentric shaft speed and the speed of vibration: one eccentric shaft rotation equals one impact. Eccentric(s) direction of rotation can be controlled automatically or manually. Eccentric speed is automatically controlled dependent upon amplitude setting.

Drum vibration is started by pressing the vibration ON/OFF switch on the hydrostatic control forward-stop-reverse lever. Vibration starts immediately when in the manual mode. When the auto vibration mode is selected, vibration is enabled with the push button on the forward-stop-reverse control lever, but will not start until the compactor reaches a pre-set speed. In order for the vibration system to operate, the engine must be at high idle, as selected by the engine idle speed switch and the travel speed must be set for compaction by the travel speed switch.

<https://www.ebooklibonline.com>

Hello dear friend!

Thank you very much for reading.

Enter the link into your browser.

The full manual is available for immediate download.

<https://www.ebooklibonline.com>

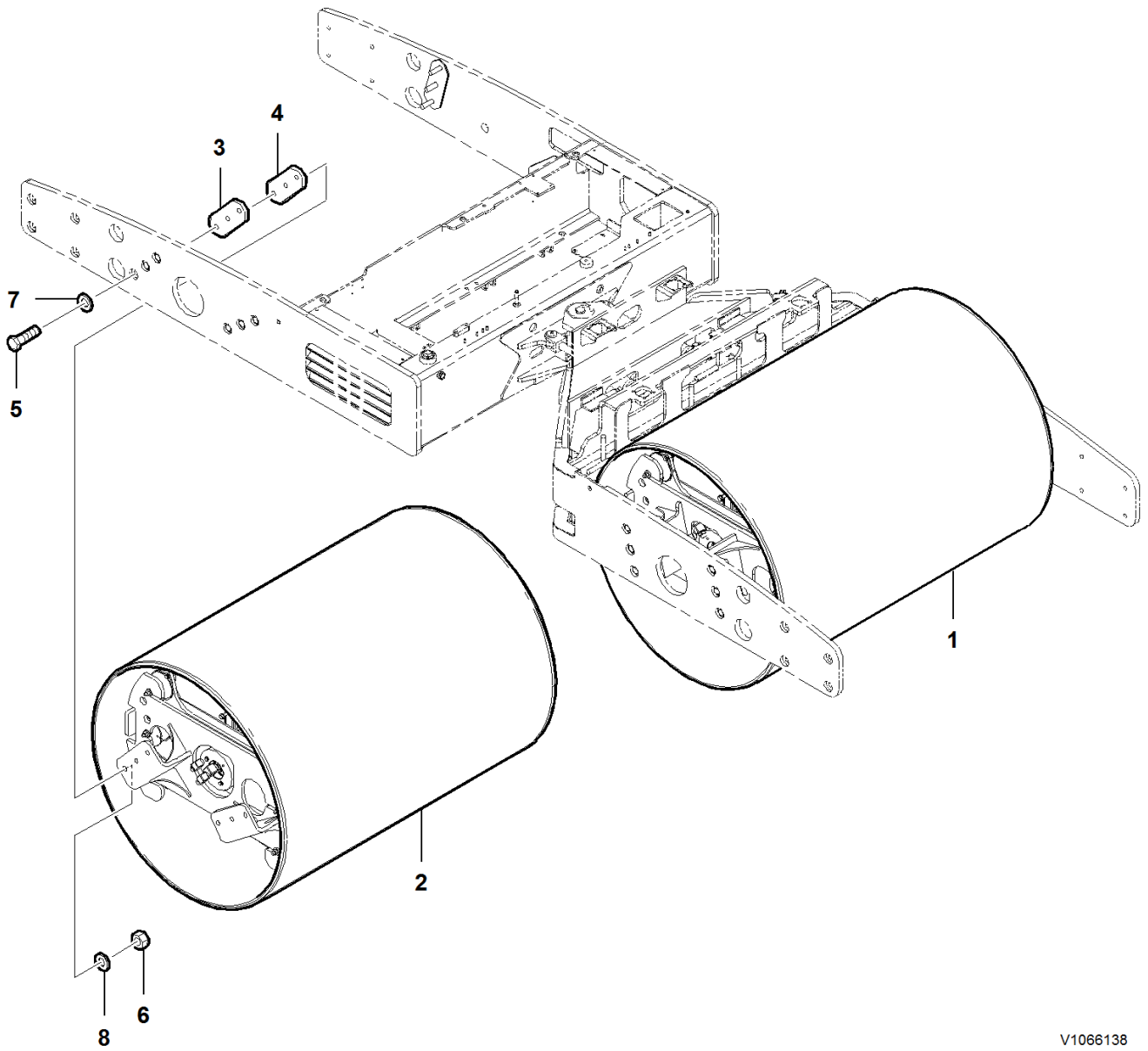

V1066138

Figure 1
Drums and components

1. Drum assembly
2. Drum assembly
3. Shim
4. Shim
5. Hexagon screw
6. Nut
7. Washer
8. Washer

Document Title: Drum eccentric, description	Function Group: 777	Information Type: Service Information	Date: 2015/11/5
Profile: COA, DD112HF, DD118HF, DD118HA [GB]			

Drum eccentric, description

The drums are each equipped with an eccentric, mounted internally which acts in a centrifugal manner. The purpose of the eccentric is to provide vibration to the drum, which aids in the compaction of the asphalt. The eccentric can be activated by a switch in the operator's platform and has 8 amplitude settings (2 amplitude settings on the DD112HF). These amplitude settings are manually set via an adjusting wheel on each drum.

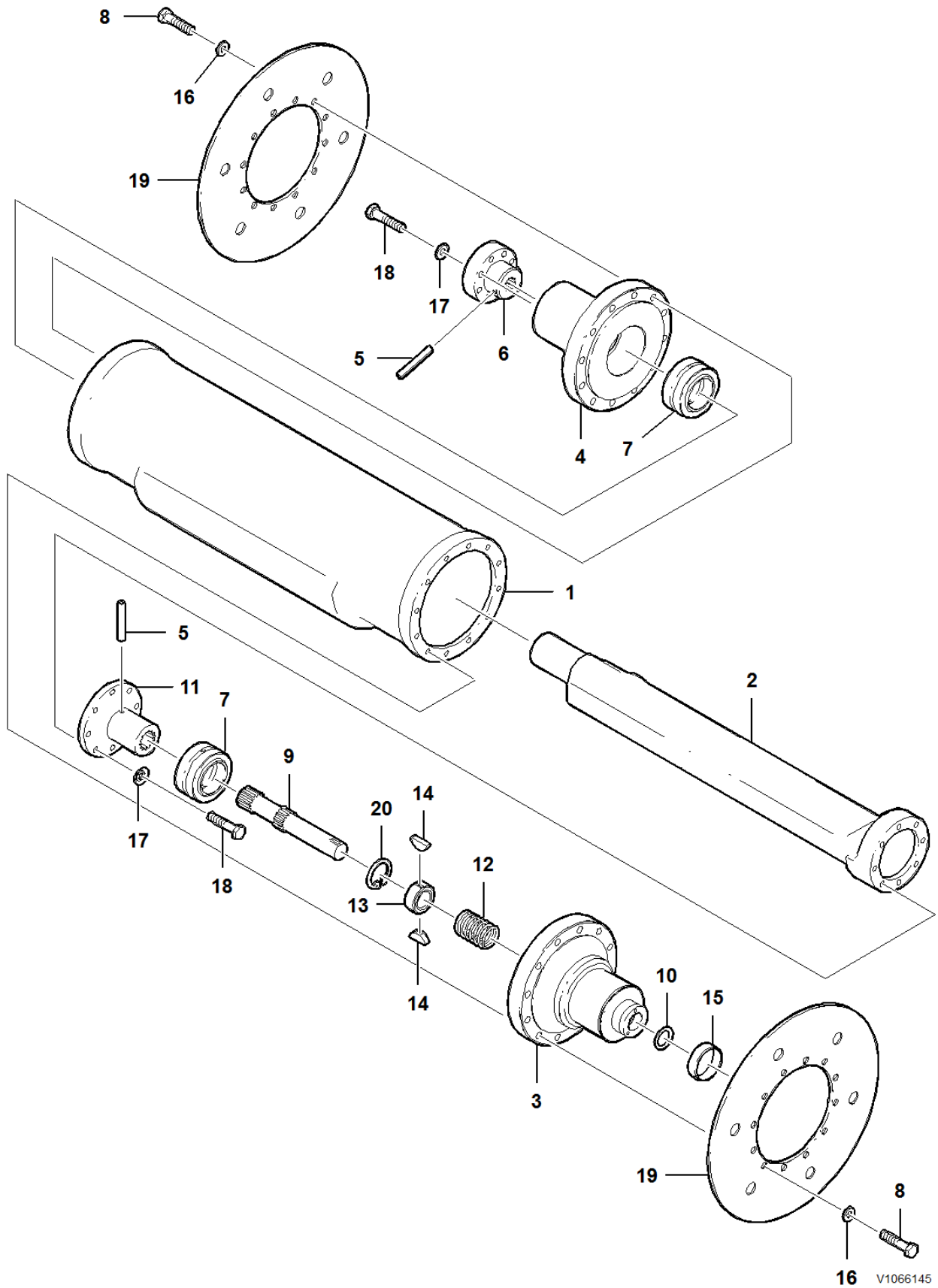

Figure 1
Drum eccentric and components

- 1. Eccentric tube
- 2. Eccentric shaft

3. Eccentric journal
4. Eccentric journal
5. Roll pin
6. Coupling
7. Bearing
8. Hexagon screw
9. Hand wheel shaft
10. O-ring
11. Shaft end
12. Spring
13. Coupling
14. Key
15. Wear sleeve
16. Washer
17. Washer
18. Hexagon screw
19. Oil slinger
20. Retaining ring

Document Title: Eccentric shaft coupling, replacing	Function Group: 777	Information Type: Service Information	Date: 2015/11/5
Profile: COA, DD112HF, DD118HFA, DD118HF, DD118HA [GB]			

Eccentric shaft coupling, replacing

Op nbr 777-010

Suitable container

Removing

1. Place the machine in the Service Position. Refer to [191 Service position](#).

NOTICE

2. **Always handle oils and other environmentally hazardous fluids in an environmentally safe manner.**

Place a suitable container underneath the vibration motor to catch any oil that may leak from the motor upon removal.

3. Remove the two hexagon screws at the vibration motor on the left side of the drum. Remove the vibration motor away from the machine.
4. Remove the coupling and shaft from the eccentric weight.

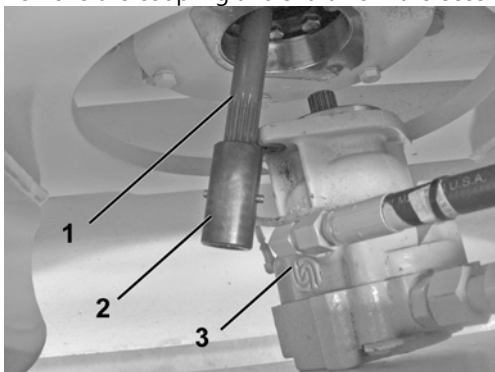

V1064813

Figure 1
Eccentric coupling and shaft

1. Shaft
2. Coupling
3. Vibration motor

Installing

5. Lubricate the new shaft and coupling. Insert the shaft into the eccentric weight.
6. Lightly coat the coupling with an approved lubricant. Install the coupling onto the splined shaft of the vibration motor.
7. Before re-installing the vibration motor, inspect the O-ring on the mounting flange and replace, if necessary.

8. Lift the vibration motor into position at the machine.
9. Re-install the hexagon screws at the vibration motor. Use a thread locking compound and torque the hexagon screws to specification. Refer to [030 Tightening torque specifications](#).
10. Repeat the above steps for the other drum.
11. Place the machine back in service.

Document Title: Drum, removing	Function Group: 777	Information Type: Service Information	Date: 2015/11/5
Profile: COA, DD112HF, DD118HFA, DD118HF, DD118HA [GB]			

Drum, removing

Op nbr 777-001

Lifting device

Lifting strap, 2m

Support stands

Wooden blocks

Container

1. Place the machine in the Service Position. Refer to [191 Service position](#).
2. Lift the frame using a suitable lifting device to take the weight off the shock mounts.

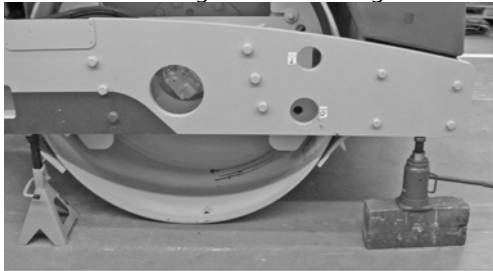

V1068652

Figure 1
Lifting device and support stand underneath the drum frame

3. Place suitable support stands underneath the back of the frame.
4. Repeat steps 2 and 3 for the other side of the drum.
5. **NOTE!**
Be sure that the water tank has been drained before removal.

Remove the wiring harness cover at the inside of the frame. Disconnect the wiring harnesses for the water pumps and lights.
6. Remove the hexagon screws that retain the water tank and front beam to the drum frame.
NOTE!
Identify and retain the shims for re-installation.
7. **WARNING**
Only use lifting devices with adequate capacity.

Attach a suitable lifting device at the water tank and front beam assembly. Carefully and safely, lift the water tank and front beam assembly out and away from the machine. **Weight of water tank and front beam assembly 425 kg (937 lbs)**

NOTE!

Do not let the water tank and front beam assembly rest on the scraper bar when placing the assembly on the floor.



V1068711

Figure 2

Water tank and front beam assembly on blocks of wood

8. Remove the hexagon screws at the drum lights. Lay the drum lights off to one side and out of the way.

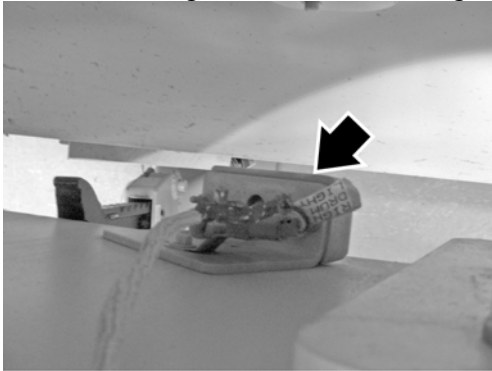

V1068717

Figure 3

Drum lights on the inside of the drum

9. Place a suitable container underneath the vibration motor to catch any oil that may escape. Remove the hexagon screws that retain the vibration motor to the drum. Lay the vibration motor and hydraulic hoses off to the side.
10. At the drum drive side of the machine, disconnect the clamps and the wiring harness at the hand wheel for the amplitude speed sensor. Pull the wiring harness through the speed sensor support shaft. Lay the wiring harness off to one side and out of the way.

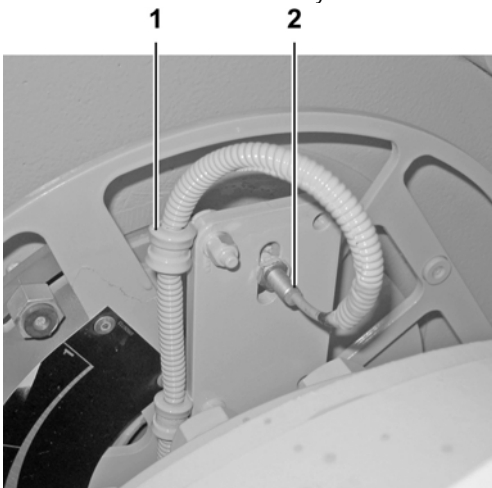

V1068714

Figure 4
Clamps and amplitude speed sensor

1. Clamp
2. Amplitude speed sensor

11. Remove the amplitude speed sensor bracket at the hand wheel.
12. Remove the hexagon screws at the speed sensor support shaft and remove the shaft from the machine.

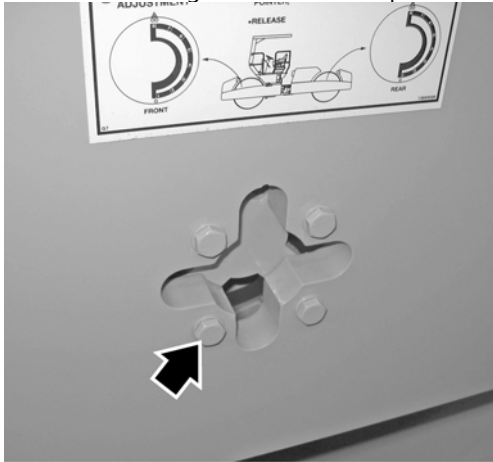

V1068715

Figure 5
Hexagon screws at the speed sensor support shaft

13. Disconnect the wiring harness for the drum drive motor.
14. **NOTE!**
Identify the hydraulic hoses before disconnecting them.

Place a suitable container underneath the drum drive motor to catch any oil that may escape. Disconnect the hydraulic hoses at the drum drive motor. Plug and cap the hoses immediately to prevent contamination of the hydraulic system.

15. Remove the hexagon screws that retain the drum to the frame.

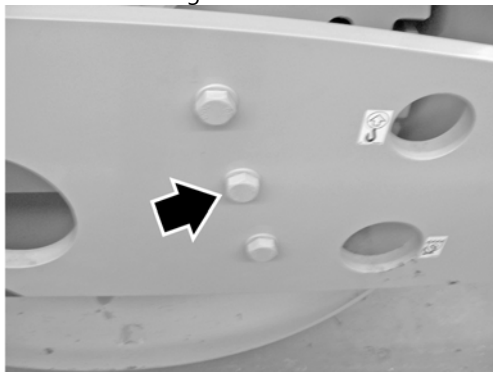

V1068718

Figure 6
Hexagon screws that retain the drum to the frame

NOTE!
Identify and retain the shims for re-installation.

16. Carefully and safely, roll the drum out and away from the drum frame.
NOTE!
Use suitable wedges or chocks to secure the drum in a fixed position.
17. Repeat the above steps for the other drum.



Suggest:

For more complete manuals. Please go to the home page.

<https://www.ebooklibonline.com>

If the above button click is invalid. Please download this document first, and then click the above link to download the complete manual.

Thank you so much for reading

Document Title: Drum, installing	Function Group: 777	Information Type: Service Information	Date: 2015/11/5
Profile: COA, DD112HF, DD118HFA, DD118HF, DD118HA [GB]			

Drum, installing

Op nbr 777-002

Hand pump

Container

1. Remove the shock mounts from the old drum and install them at the new drum.
2. Fill the drum with clean oil. Refer to [173 Drum eccentric, changing oil](#) and [173 Drum carrier, changing oil](#).
3. Carefully and safely, roll the drum into position at the drum frame.
4. Install a suitable hand pump at the drum drive motor to manually release the brake in order to line up the holes on the torque hub with the frame.

NOTE!

Do not exceed 24 bar (350 psi). Excessive pressure may result in seal damage.

5. Re-install the hexagon screws and shims that retain the drum to the frame. Do not tighten the hexagon screws at this point.

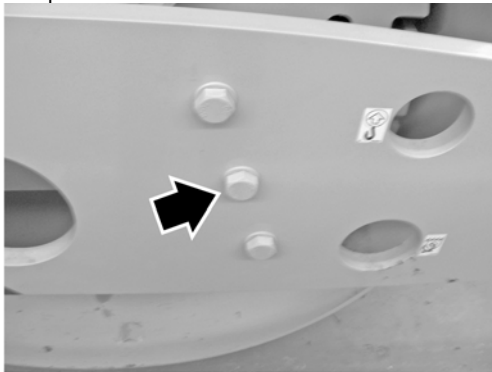

V1068718

Figure 1

Hexagon screws that retain the drum to the frame



6. **Only use lifting devices with adequate capacity.**
Carefully and safely, lift the water tank and front beam assembly into place at the drum. Weight of water tank and front beam assembly **425 kg (937 lbs)**
7. Re-install the shims and hexagon screws that retain the water tank and front beam assembly to the drum frame. Do not tighten the hexagon screws at this point.
8. Using a suitable locking compound, torque tighten the hexagon screws that retain the drum to the frame. Refer to [030 Critical mounting torques](#).
9. Using a suitable locking compound, torque tighten the hexagon screws that retain the water tank and front beam

assembly to the frame. Refer to [030 Tightening torque, specifications](#).

10. Re-install the hydraulic hoses at the drum drive motor.
11. Connect the wiring harness for the drum drive motor.
12. Re-install the speed sensor support shaft. Retain the shaft with the hexagon screws.

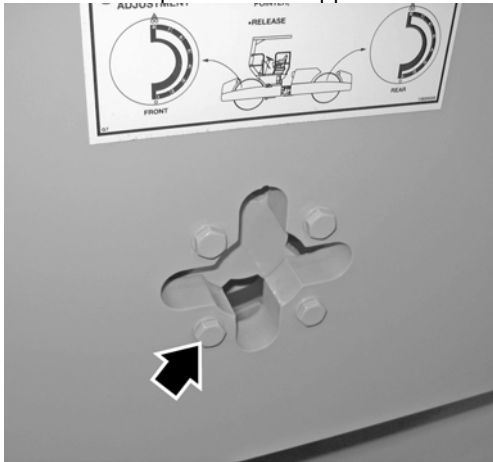

V1068715

Figure 2
Hexagon screws at the speed sensor support shaft

13. **NOTE!**
Feed the speed sensor wiring harness through the speed sensor support shaft before re-installing the amplitude speed sensor bracket.

Re-install the amplitude speed sensor bracket at the hand wheel.
14. Re-install the clamps and the wiring harness at the hand wheel for the amplitude speed sensor.
NOTE!
Be sure that the speed sensor and the magnet on the indicator are positioned so that they meet when the drum turns.

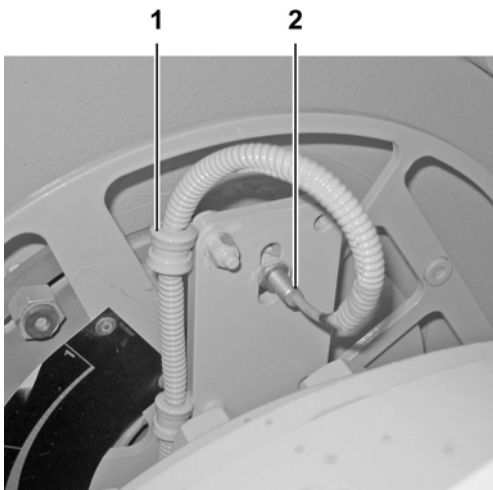

V1068714

Figure 3
Clamps and amplitude speed sensor

1. Clamp
2. Amplitude speed sensor

15. Re-install the vibration motor to the drum. Using a suitable thread locking compound, torque the hexagon screws

<https://www.ebooklibonline.com>

Hello dear friend!

Thank you very much for reading.

Enter the link into your browser.

The full manual is available for immediate download.

<https://www.ebooklibonline.com>