

FOREWORD

This repair manual covers the inspection, adjustment and repair procedures for the overhaul of the engine, chassis and materials handling system of the TOYOTA SKID STEER LOADER SDK10.

You are encouraged to become thoroughly familiar with this manual so as to make the most of the outstanding performance and durability features of these loaders and to perform the proper servicing to maintain them in tip-top running condition.

This repair manual contains the latest information available as of March, 1989. For any changes thereafter, you are asked to consult the Parts & Service News. Toyota reserves the right to make changes in specifications without incurring any obligation and without previous notice.

For your reference, we herewith indicate the titles of relevant manuals.

TOYOTA 1Z ENGINE REPAIR MANUAL (No. CE601)

TOYOTA MOTOR CORPORATION

SECTION INDEX

	SECTION
GENERAL	0
ENGINE	1
HYDROSTATIC TRANSMISSION	2
FINAL REDUCTION GEAR	3
STEERING	4
AXLE	5
BRAKES	6
BODY FRAME	7
LIFT ARMS & BUCKET BRACKET	8
CYLINDERS	9
OIL PUMP	10
OIL CONTROL VALVE	11
HYDRAULIC SYSTEM	12
APPENDIX	13

GENERAL

0

	Page
VEHICLE EXTERIOR VIEWS	0-2
VEHICLE MODELS	0-3
ABBREVIATION	0-3
OPERATIONAL TIPS	0-4
STANDARD BOLT & NUT TIGHTENING TORQUE ...	0-5
PRECOATED BOLTS	0-7
HIGH-PRESSURE HOSE FITTING TIGHTENING TORQUE	0-7
WIRE ROPE SUSPENSION ANGLE LIST	0-8
SAFE LOAD FOR EACH WIRE ROPE SUSPENSION ANGLE	0-8
COMPONENTS WEIGHT	0-9
FRAME SERIAL NUMBER	0-9
RECOMMENDED LUBRICANTS & CAPACITIES	0-10
LUBRICATION	0-11
PERIODIC REPLACEMENT PARTS AND LUBRICANTS	0-12
PERIODIC MAINTENANCE	0-13

<https://www.ebooklibonline.com>

Hello dear friend!

Thank you very much for reading.

Enter the link into your browser.

The full manual is available for immediate download.

<https://www.ebooklibonline.com>

VEHICLE EXTERIOR VIEWS



Front View

SAG5-32



Rear View

SAG5-26

VEHICLE MODELS

Model	Engine	Operating Load	Bucket Capacity	Machine Weight
SDK10	TOYOTA 1Z	820 kg (1,808 lb)	0.35 m ³ (12.5 ft ³)	3,030 kg (6,681 lb)

ABBREVIATION

Abbreviation (Code)	Measuring
ABDC	After bottom dead center
ASSY	Assembly
ATDC	After top dead center
BBDC	Before bottom dead center
BTDC	Before top dead center
CCA	Cold cranking amperes
HST	Hydrostatic transmission
LH	Left hand
OHV	Over head valve
OPT	Option
OR	Off road
PR	Ply rating
RH	Right hand
SAE	Society of Automotive Engineers (USA)
SST	Special service tool
STD	Standard
SUB-ASSY	Sub-assembly
T =	Tightening torque
OOT	Number of teeth (OO)

OPERATIONAL TIPS

1. Safe operations
 - (1) Carry out inspections and servicing with the rear arm lowered and the bucket on the ground. If the inspections and servicing must be performed with the rear arm in the air, use the safety block or safety pillar to prevent the arm from lowering.
 - (2) Always use rigid racks or stands when jacking up the vehicle.
 - (3) When lifting with a wire rope, make sure the rope is sufficiently strong.
2. Preparation of SSTs and measuring tools
 - (1) Prepare SSTs and measuring tools before starting operation.
3. Clearing and arrangement
 - (1) Always keep the workshop neat and orderly for easy operation.
 - (2) Disassembly of hydraulic equipment shall always be done in a clean place using clean tools.
4. Genuine Toyota parts

Genuine Toyota parts should be used even in the replacement of packings, gaskets and O-rings.
5. Repairs on electrical system

Before doing any repairs on the electrical system, disconnect the cables from the battery terminals. Be sure to disconnect the negative — cable first.
6. Tightening torque for installation

Be sure to observe the tightening torque given in this manual. If not specified, tighten to the torque listed in Standard bolt & nut tightening torque.
7. Defect status grasp

Do not start disassembly and replacement as soon as a defect is found, but first grasp whether the defect requires disassembly and replacement. For example, with the HST, the pump should not be immediately turn down simply because there is trouble with the travel system. Troubleshoot the cause in the steering levers, the final reduction gear, the change oil pressure, the hydraulic oil and so on.









STANDARD BOLT & NUT TIGHTENING TORQUE

Tightening torques for standard bolts and nuts are not explicitly indicated in this manual. They are pre-determined. To get the tightening torque, follow this procedure:

1. Find out the type of the bolt from the list below.
Then, find the bolt tightening torque from the table.
2. The nut tightening torque can be judged from the bolt type. (See the table.)

LIST OF BOLT TYPES AND STRENGTH

1. Judging by part:

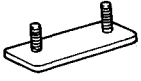
Shape and description		Type
Hexagon bolt (Standard bottom surface)	 Number on the head	4 = 4T 5 = 5T 6 = 6T 7 = 7T
	 No mark	4T
Hexagon bolt (Collared bottom)	 No mark	4T
Hexagon bolt (Standard bottom surface)	 Two protruding lines on the head	5T
Hexagon bolt (Collared bottom)	 Two protruding lines on the head	6T
Hexagon bolt	 Three protruding lines on the head	7T
Welding bolt	 No mark	4T
Stud bolt	 Approx. 2 mm (0.08 in.) hollow on either or both ends	6T
Welded bolt		4T

SAGS49

2. Judging by part No.

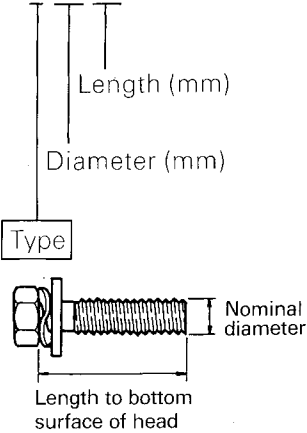
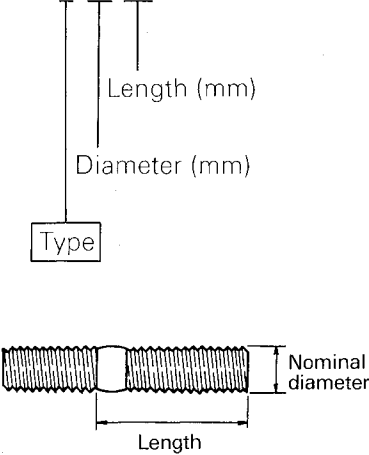
Hexagon bolt
<p>Sample number 91111-4 06 20</p> 
<p>Stud bolt</p> <p>Sample number 92132-4 06 20</p> 

BAHS25

STANDARD BOLT TIGHTENING TORQUE

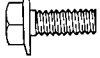
Type	Diameter mm	Pitch mm	Standard tightening torque kg-cm (ft-lb)	
			Standard seat 	Seat with flange 
4T	6	1	55 (48 in.-lb)	60 (52 in.-lb)
	8	1.25	130 (9)	145 (10)
	10	1.25	260 (19)	290 (21)
	12	1.25	480 (35)	540 (39)
	14	1.5	760 (55)	850 (61)
	16	1.5	1,150 (83)	—
5T	6	1	65 (56 in.-lb)	—
	8	1.25	160 (12)	—
	10	1.25	330 (24)	—
	12	1.25	600 (43)	—
	14	1.5	930 (67)	—
	16	1.5	1,400 (101)	—
6T	6	1	80 (69 in.-lb)	90 (78 in.-lb)
	8	1.25	195 (14)	215 (16)
	10	1.25	400 (29)	440 (32)
	12	1.25	730 (53)	810 (59)
	14	1.5	1,100 (79)	1,250 (90)
7T	6	1	110 (8)	120 (9)
	8	1.25	260 (19)	290 (21)
	10	1.25	530 (38)	590 (43)
	12	1.25	970 (70)	1,050 (76)
	14	1.5	1,500 (108)	1,700 (123)
	16	1.5	2,300 (166)	—

BAHS26

PRECOATED BOLTS

(BOLTS WITH SEAL LOCK AGENT COATING ON THREADS)

1. Do not use the precoated bolt in either of the following cases without any special treatment described below:
 - (a) After it is removed.
 - (b) When the precoated bolt is moved (loosened or tightened) for tightness check, etc.

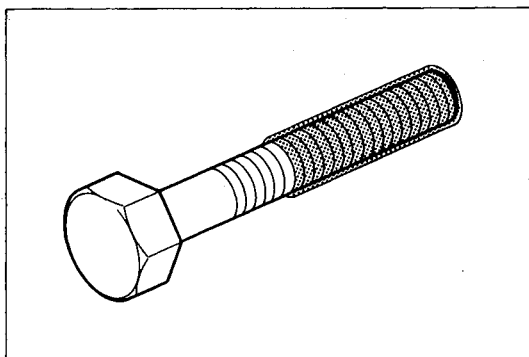

Precoated Bolts

KAKS25

Note:

For torque check, use the lower limit of the allowable tightening torque range. If the bolt moves, retighten it according to the steps below.

2. Method for reuse of precoated bolts
 - (1) Wash the bolt and threaded hole. (The threaded hole must be washed even for replacement of the bolt.)
 - (2) Perfectly dry the washed parts by air blowing.
 - (3) Apply the specified seal lock agent to the threaded portion of the bolt.

HIGH-PRESSURE HOSE FITTING TIGHTENING TORQUE

1. When connecting a high-pressure hose, wipe the hose fitting and mating nipple contact surfaces with a clean cloth to remove foreign matters and dirt. Also check no dent or other damage on the contact surfaces before installation.
2. When connecting a high-pressure hose, hold the hose to align the fitting with the nipple and tighten the fitting.
3. The maximum tightening torque must not exceed twice the standard tightening torque.

Nominal diameter of screw	Standard tightening torque kg-m (ft-lb)		Hose inside diameter (mm)
	Standard	Torque range	
$\frac{7}{16}$ —20UNF	2.5 (18.1)	2.4 ~ 2.6 (17.4 ~ 18.8)	6
$\frac{9}{16}$ —18UNF	5.0 (36.2)	4.8 ~ 5.3 (34.7 ~ 38.3)	9
$\frac{3}{4}$ —16UNF	6.0 (43.4)	5.7 ~ 6.3 (41.2 ~ 45.5)	12
$\frac{7}{8}$ —14UNF	6.0 (43.4)	5.7 ~ 6.3 (41.2 ~ 45.5)	12
$1\frac{1}{16}$ —12UNF	12.0 (86.8)	11.4 ~ 12.6 (82.4 ~ 91.1)	19
$1\frac{5}{16}$ —12UNF	14.0 (101.2)	13.3 ~ 14.7 (96.2 ~ 106.3)	25
PF1/4	5.0 (36.2)	4.8 ~ 5.3 (34.7 ~ 38.3)	9
PF3/8	5.0 (36.2)	4.8 ~ 5.3 (34.7 ~ 38.3)	9
PF1/2	6.0 (43.4)	5.7 ~ 6.3 (41.2 ~ 45.5)	12
PF3/4	12.0 (86.8)	11.4 ~ 12.6 (82.4 ~ 91.1)	19
PF1	14.0 (101.2)	13.3 ~ 14.7 (96.2 ~ 106.3)	25

WIRE ROPE SUSPENSION ANGLE LIST

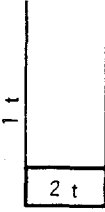
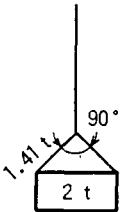
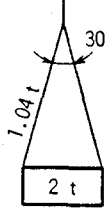
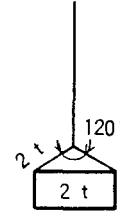
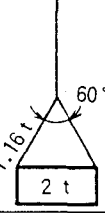
Lifting angle	Tension	Compression	Suspension method	Lifting angle	Tension	Compression	Suspension method
0°	1.00 time	0 time		90°	1.41 time	1.00 time	
30°	1.04 time	0.27 time		120°	2.00 time	1.73 time	
60°	1.16 time	0.58 time					

JAEM88

SAFE LOAD FOR EACH WIRE ROPE SUSPENSION ANGLE

Unit: ton (lb)

Rope diameter	Cutting load	Single-rope suspension	Two-rope suspension					Four-rope suspension			
		0°	0°	30°	60°	90°	0°	30°	60°	90°	
6 mm (0.24 in.)	2.18 (4,807)	0.31 (683.6)	0.62 (1,367)	0.6 (1,323)	0.53 (1,169)	0.44 (970)	1.24 (2,734)	1.2 (2,646)	1.06 (2,337)	0.88 (1,940)	
8 mm (0.32 in.)	3.21 (7,078)	0.45 (992.3)	0.9 (1,985)	0.87 (1,918)	0.78 (1,720)	0.64 (1,411)	1.8 (3,969)	1.74 (3,937)	1.56 (3,440)	1.28 (2,822)	
10 mm (0.4 in.)	5.02 (11,069)	0.71 (1,565.6)	1.43 (3,153)	1.37 (3,021)	1.2 (2,646)	1.0 (2,205)	2.8 (6,174)	2.7 (5,954)	2.4 (5,292)	2.0 (4,410)	
12.5 mm (0.5 in.)	7.84 (17,387)	1.12 (2,469.5)	2.2 (4,851)	2.1 (4,631)	1.9 (4,190)	1.5 (3,308)	4.4 (9,702)	4.2 (9,261)	3.8 (8,379)	3.0 (6,615)	
14 mm (0.56 in.)	9.83 (21,675)	1.4 (3,087)	2.8 (6,174)	2.7 (5,954)	2.4 (5,292)	1.9 (4,190)	5.6 (12,348)	5.4 (11,907)	4.8 (10,584)	3.8 (8,379)	

COMPONENTS WEIGHT

Item	Weight kg (lb)
Engine	237 kg (522.6)
HST Pump	Approx. 56 kg (123.5)
HST Motor	Approx. 12 kg (26.5)
Drive Unit	Approx. 60 kg (132.3)
Bucket	Approx. 160 kg (352.9)
Oil Control Valve	Approx. (2-Way) 10 kg (22.1)

FRAME SERIAL NUMBER

Frame Serial Number Location

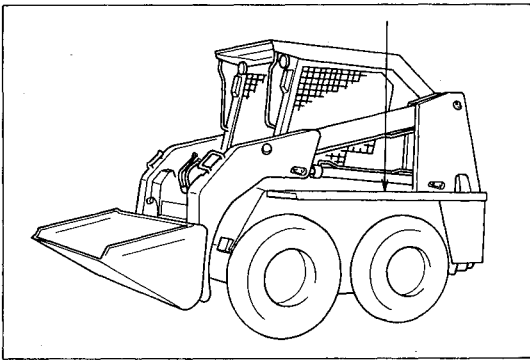

Frame Serial Number Location

SAGS36

Frame Numbering System

Vehicle	Serial Number
SDK10	SDK10 -- 10011

ENGINE ASSY

REMOVAL

1. Remove the engine hood.
 - (1) Set bolts (4 pcs.)
 - (2) Engine hood

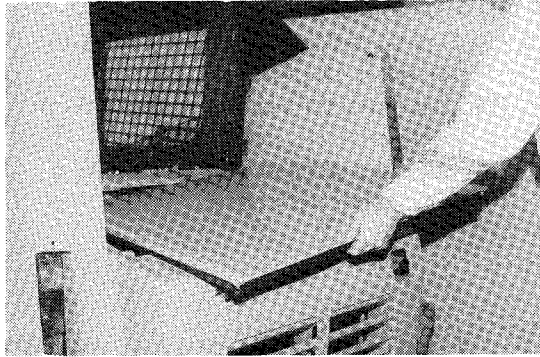

Removing the Engine Hood

SAG8-3

2. Disconnect the battery earth cable.
 - (1) Open the rear grille.
 - (2) Disconnect the battery earth cable.
3. Drain the coolant.
 - (1) Prepare a coolant receiving container.
 - (2) Loosen the radiator drain cock.

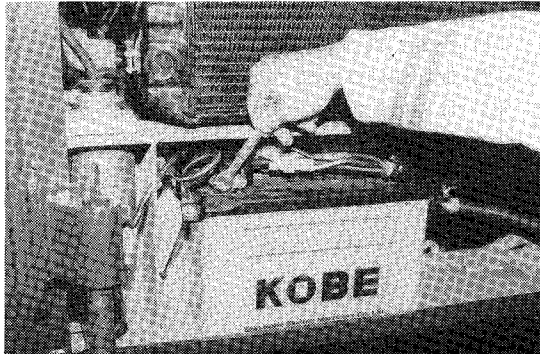

Disconnecting the Battery Earth Cable

SAG8-4

4. Remove the radiator.
 - (1) Disconnect the inlet hose (on the engine side).
 - (2) Disconnect the outlet hose (on the engine side).
 - (3) Disconnect the reservoir tank hose on the tank side.
 - (4) Set bolts (4 pcs.)

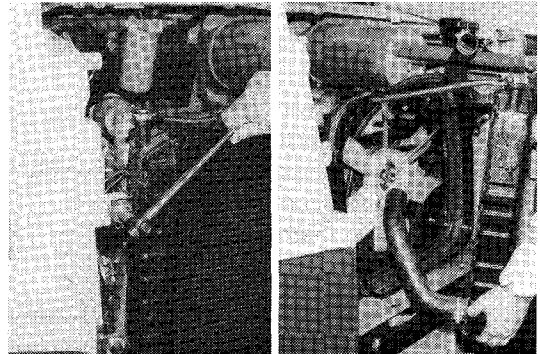

Removing the Radiator

SAG8-8, 12

5. Remove the fan shroud.
 - (1) Set bolts (2 pcs.)
 - (2) Fan shroud

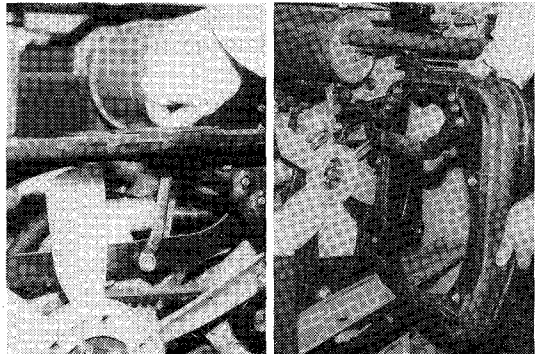

Removing the Fan Shroud

SAG8-13, 14

6. Remove the air cleaner.
 - (1) Disconnect the air cleaner hose (on the engine side).
 - (2) Disconnect the wiring to the vacuum sensor.
 - (3) Set bolts (2 pcs.)
 - (4) Air cleaner with hose

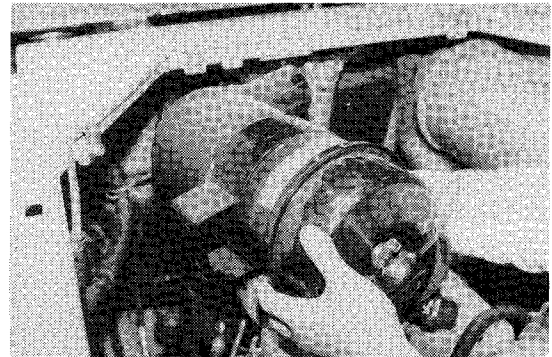

Removing the Air Cleaner

SAG8-19

7. Remove the muffler and exhaust pipe.
 - (1) Exhaust pipe set nuts (3 pcs.)
 - (2) Muffler clamp set bolt (2 pcs.)
 - (3) Spacer and cushion
 - (4) Muffler and exhaust pipe with muffler clamp

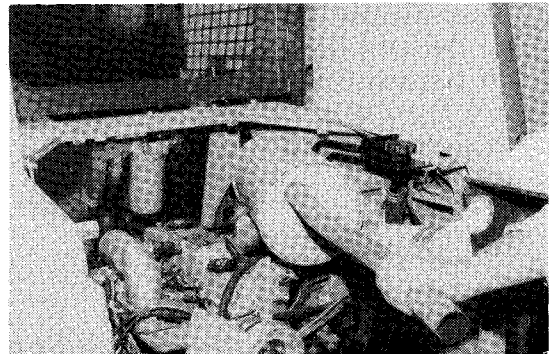

Removing the Muffler & Exhaust Pipe

SAG8-22

8. Disconnect the head tank to fuel tank hose (on the fuel tank side).
9. Disconnect the wirings.
 - (1) Wiring to starting motor
 - (2) Wiring to engine oil pressure switch
 - (3) Wiring to alternator
 - (4) Wiring to thermostat plug

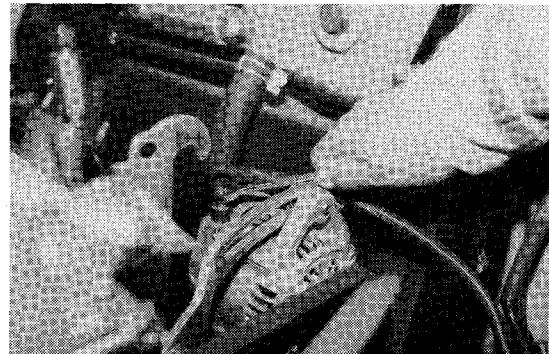

Disconnecting the Wiring (Alternator)

SAG8-23

10. Disconnect the accelerator wire.
 - (1) Cotter pin and plate washer
 - (2) Pin
 - (3) Remove the accelerator wire from the clamp.

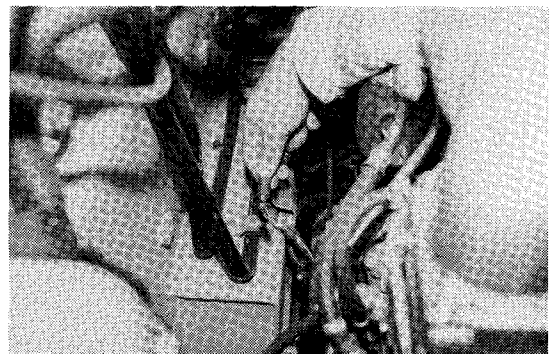

Disconnecting the Accelerator Wire

SAG8-26

11. Drain the hydraulic oil.

- (1) Prepare a hydraulic oil receiving container.
- (2) Drain plug

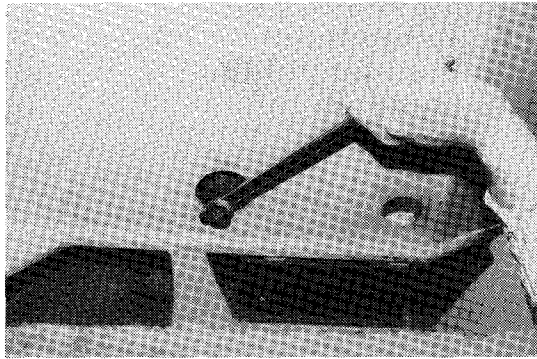

Draining the Hydraulic Oil

SAG8-27

12. Disconnect the oil pump piping.

- (1) Low-pressure hose
 - ① HST outlet hose side
 - ② HST inlet hose side
 - ③ Hydraulic oil tank side
- (2) Oil pump piping
 - ① Set bolts (4 pcs.)

Caution:

Fit nylon cap or other covers to the hose, pipe and oil pump ports to prevent entrance of foreign matters.

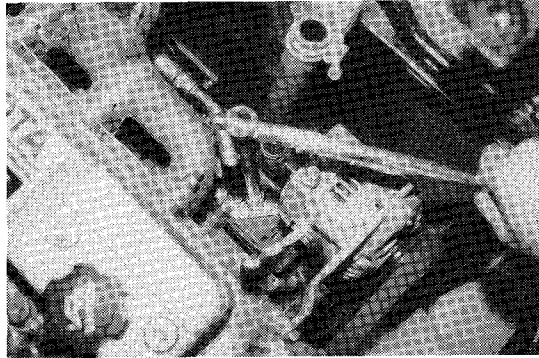

Disconnecting the Oil Pump Piping

SAG8-30

13. Remove the engine oil drain from the frame.

- (1) Set bolts (2 pcs.)
- (2) Engine oil drain

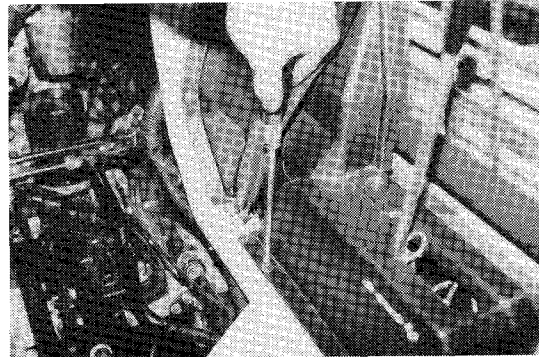

Removing the Ducts LH and RH

SAG9-6

14. Remove the operator guard.

- (1) Ducts LH and RH
 - ① Set screws (6 pcs.)
 - ② Ducts LH and RH
- (2) Disconnect the wirings.
 - ① Main harness
 - ② Wiring to horn
 - ③ Wiring to pedal lock solenoid
 - ④ Earth cable
- (3) Set bolts (4 pcs.)
- (4) Operator guard

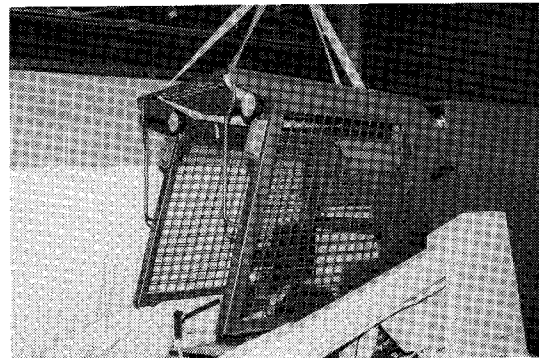

Removing the Operator Guard

SAG9-13

15. Remove the driver's seat.
- (1) Set bolts (6 pcs.)
 - (2) Disconnect the wiring.
 - (3) Driver's seat

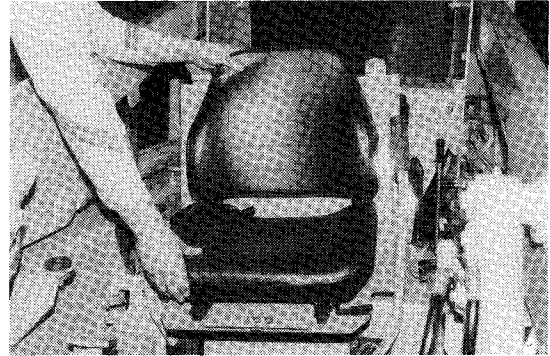

Removing the Drivers Seat

SAG9-17

16. Remove the backup lamp switch.
- (1) Backup lamp switch LH
 - ① Disconnect the wiring. (2 pcs.)
 - ② Backup lamp switch LH
 - (2) Backup lamp switch RH
 - ① Disconnect the wiring. (2 pcs.)
 - ② Backup lamp switch RH

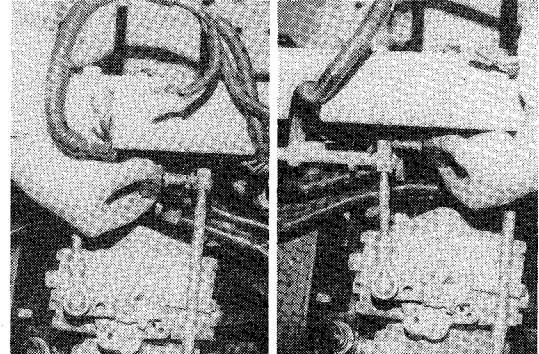

Removing the Backup Lamp Switch

SAG9-18, 19

17. Remove the steering link.
- (1) Steering link LH
 - ① Set nuts (2 pcs.)
 - ② Steering link LH
 - (2) Steering link RH
 - ① Set nuts (2 pcs.)
 - ② Steering link RH

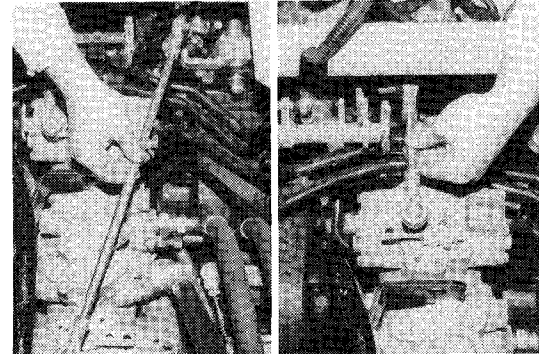

Removing the Steering Link

SAG9-20, 21

18. Disconnect the HST filter piping.

Caution:

Fit nylon caps or other covers to hoses and elbows to prevent entrance of foreign matters.

- (1) High-pressure hose (3 pcs.)



Disconnecting the HST Filter Piping

SAG9-32

19. Disconnect the HST piping.

Caution:
Fit nylon caps or other covers to hoses and elbows to prevent entrance of foreign matters.

(1) High-pressure hose (4 pcs.)

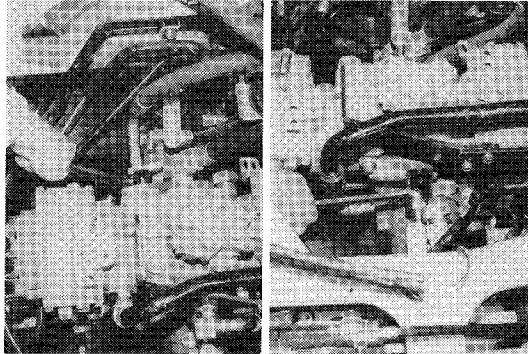

Disconnecting the High-Pressure Hose SAG9-23, 25

(2) Low-pressure hose (2 pcs.)

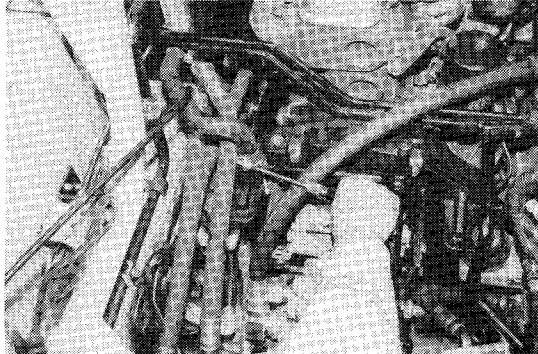

Disconnecting the Low-Pressure Hose SAG9-33

20. Disconnect the body earth cable.

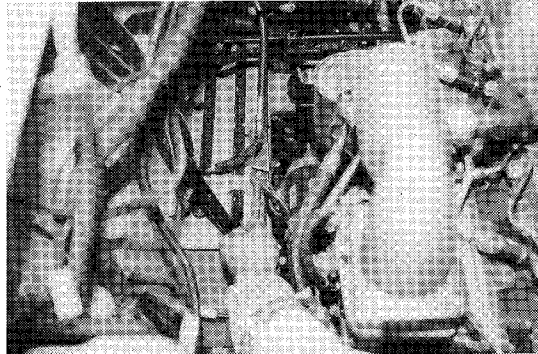

Disconnecting the Body Earth Cable SAG9-26

21. Remove the lift cylinder piping.

(1) Lift cylinder piping

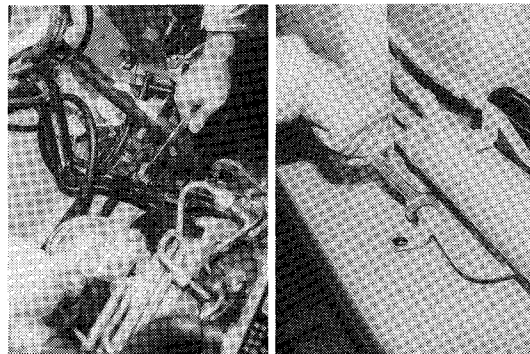

Removing the Lift Cylinder Piping SAG9-34, 37

22. Disconnect the fuel hose (on the engine side).

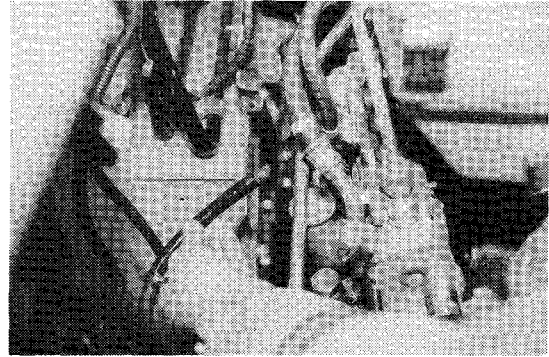

Disconnecting the Fuel Hose

SAG9-30

23. Disconnect the brake wire bracket LH.

- (1) Brake wire
 - ① Cotter pin
 - ② Plate and pin
- (2) Brake wire bracket
 - ① Set bolts (2 pcs.)
 - ② Brake wire bracket

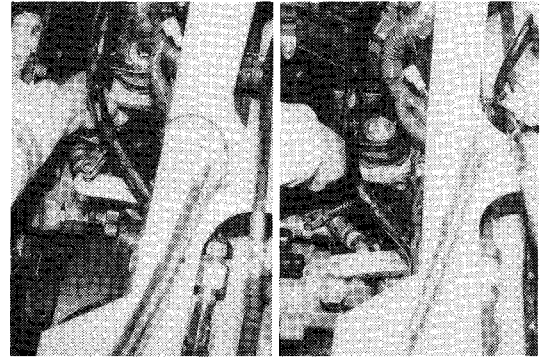

Disconnecting the Brake Wire Bracket LH SAG9-31, 32

24. Disconnect the battery earth cable.
(1) Disconnect the battery earth cable.

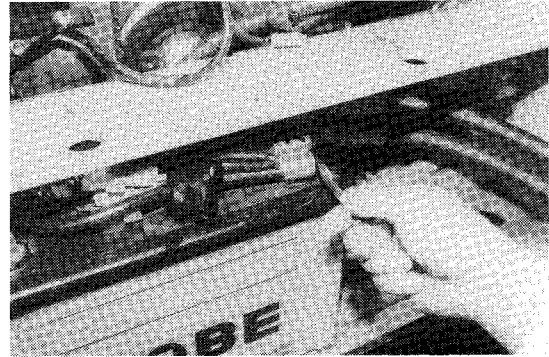

Disconnecting the Battery Earth Cable

SAG9-28

25. Disconnect the fusible link connector.

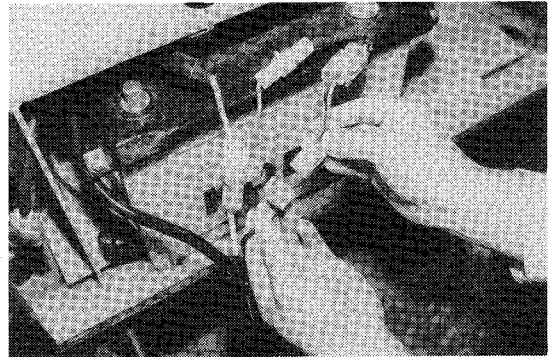

Disconnecting the Fusible Link Connector

SAG9-29

26. Remove the engine with HST pump.

(1) Mounting set nuts (4 pcs.)

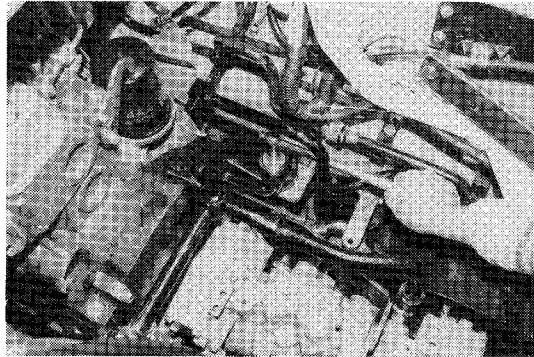

Removing the Mounting Set Nuts

SAG9-39

(2) Remove the engine with HST pump according to the procedure described below.

① Prepare two 1.5 m (59 in.) wires and connect them to the front of the HST pump: The one wire to the front of the HST pump and set the other wire as shown so that the wire length can be adjusted. (See the figure at right.) Move the part A (in the figure above) upward to lengthen the wire and downward to shorten it.

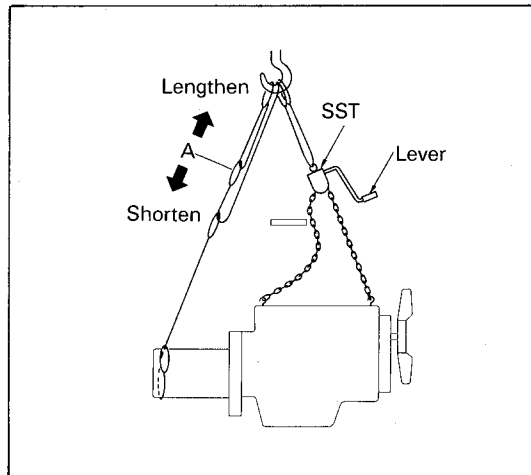

Setting the Wires and Engine Sling Device (SST)

SAGM33

② Set the chain hook on one side of the engine sling device (SST 09090-04000) to the rear side engine hanger. Set the other chain hook to the chain fitted to the engine hanger.

③ Adjust the wire and chain lengths so that the hoist hook comes right above the frame member.

[Wire length adjustment]

Move the part A (in the figure above) upward to lengthen the wire and downward to shorten it.

[Chain length adjustment]

Turn the engine sling device lever for length adjustment.

④ Hoist the engine with HST pump.

Caution:

Be sure that all wirings and pipings are disconnected.

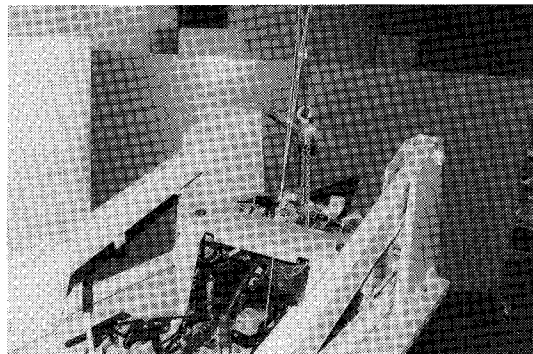

Hoisting the Engine

SAG10-21

- ⑤ Move the engine with HST pump to the rear, and stop the movement where the wire comes into contact with the frame member.
- ⑥ Set the free chain hook of the engine sling device (SST 09090-04000) to the front side engine hanger.
- ⑦ Operate the engine sling device (SST) lever to bring the HST pump up and loosen the wire tension.
- ⑧ Disconnect the wire at the hoist side shackle, and suspend the engine with HST pump only with the engine sling device (SST).
- ⑨ Operate the lever on the engine sling device (SST) to bring up the HST pump side and loosen the wire tension.
- ⑩ Remove the engine with HST pump.

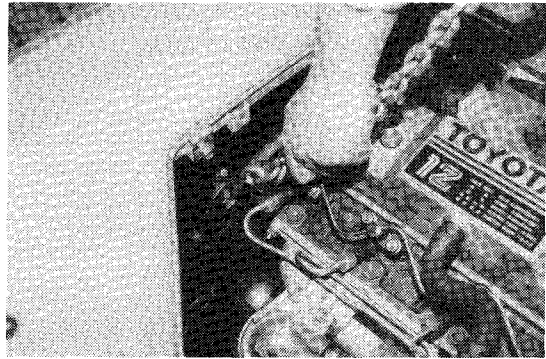

Setting the Chain Hook to Front Engine Hanger

SAG10-24

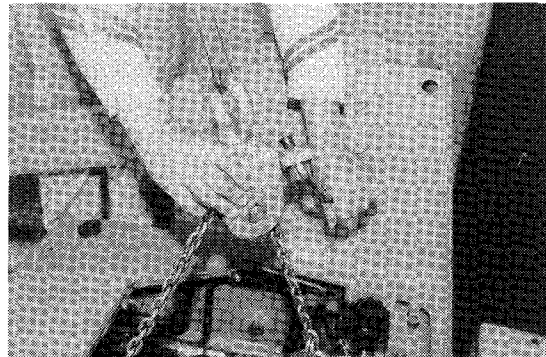

Operating the Engine Sling Device Lever

SAG10-23

27. Remove the oil pump.

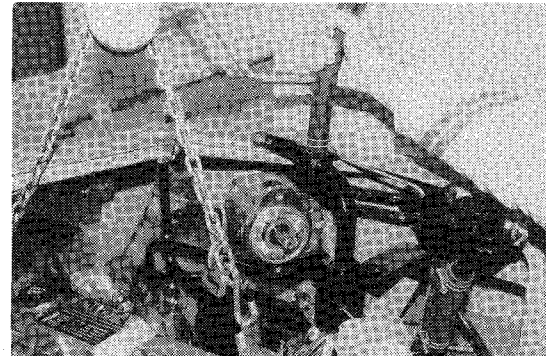

Removing the Oil Pump

SAG10-25

28. Remove the engine with HST pump.

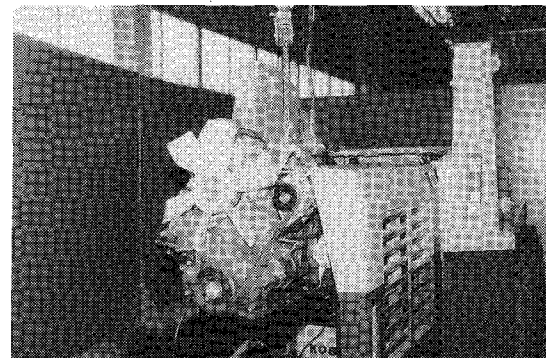

Removing the Engine with HST Pump

SAG10-18



Suggest:

For more complete manuals. Please go to the home page.

<https://www.ebooklibonline.com>

If the above button click is invalid. Please download this document first, and then click the above link to download the complete manual.

Thank you so much for reading

29. Place the engine with HST pump in stable state.
30. Separate the HST pump from the engine.
- (1) Slightly suspend the HST pump with a wire rope.
 - (2) HST pump set bolts (4 pcs.)
 - (3) HST pump

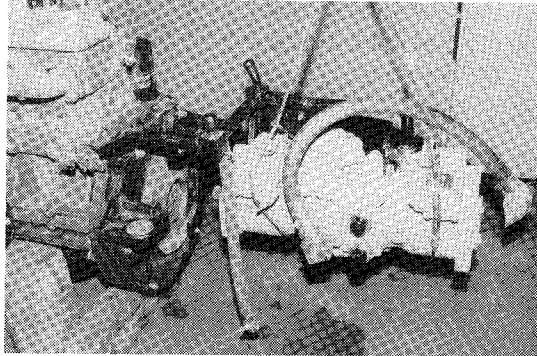

Separating the HST Pump from the Engine SAG10-4

31. Remove the HST pump support.
- (1) Set bolts (6 pcs.)
 - (2) HST pump support

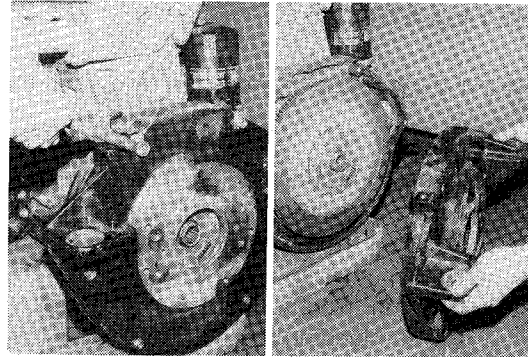

Removing the HST Pump Support SAG10-7, 9

32. Remove the starter.
- (1) Set bolts (2 pcs.)
 - (2) Starter

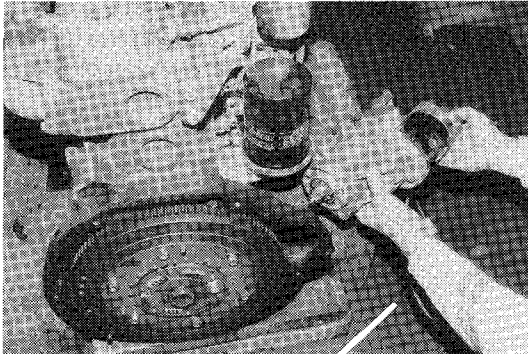

Removing the Starter SAG10-12

33. Remove the damper.
- (1) Set bolts (6 pcs.)
 - (2) Damper

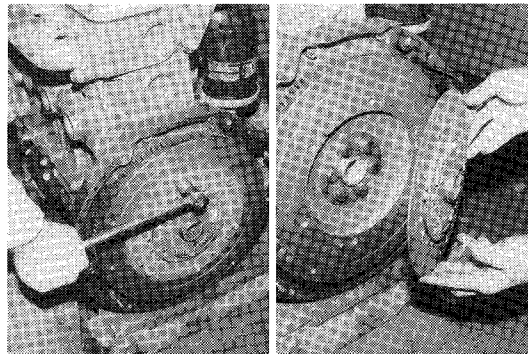

Removing the Damper SAG10-14, 15

34. Remove the flywheel.
- (1) Set bolts (6 pcs.)
 - (2) Flywheel

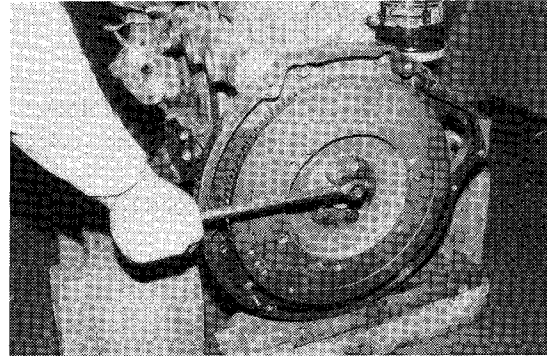

Removing the Flywheel

SAG10-16

INSTALLATION

The installation procedure is the reverse of the removal procedure.

Cautions:

- Apply molybdenum-disulfide grease to the spline portions of the HST pump and damper before installing the HST pump to the engine.
- Connect the battery earth cable after checking correctness of all electrical wiring connections.
Bleed air from the fuel system. See "Air Bleeding from Fuel System" on the next page for the air bleeding procedure.
- Always inspect the hydraulic oil, coolant, and engine oil before starting the engine, and add to the specified level if insufficient.
- When starting the engine, set the steering control lever at the neutral position and warm up the engine and HST pump at the idling speed.
- Start the engine (at a low speed) and check if steering control lever neutral adjustment is proper.
If not, adjust the spring holder according to the procedure in the "STEERING-Steering Neutral Adjustment" section (on page 4-9).
- Bleed air from the hydraulic circuit according to the procedure in the "HYDRAULIC SYSTEM-Bleeding Air from Hydraulic Circuit" section (on page 12-4).

<https://www.ebooklibonline.com>

Hello dear friend!

Thank you very much for reading.

Enter the link into your browser.

The full manual is available for immediate download.

<https://www.ebooklibonline.com>