



**D  
REPAIR**

**M  
MANUAL**

**1DZ-II ENGINE**

**Pub. No. CE618-2**

# FOREWORD

This repair manual explains the repair points of the 1DZ-II model engine equipped on the Toyota Forklift Trucks.

Please make good use of this manual for your technical service.

This repair manual contains the latest information available as of August 1998. For any changes thereafter, Toyota reserves the right to make such changes in specifications and descriptions without incurring any obligation and without previous notice.

**TOYOTA Material Handling Company**  
A Division of TOYOTA INDUSTRIES CORPORATION

# SECTION INDEX

NAME	SECTION
<b>GENERAL</b>	<b>0</b>
<b>ENGINE TUNE-UP</b>	<b>1</b>
<b>ENGINE OVERHAUL</b>	<b>2</b>
<b>FUEL SYSTEM</b>	<b>3</b>
<b>COOLING SYSTEM</b>	<b>4</b>
<b>LUBRICATION SYSTEM</b>	<b>5</b>
<b>STARTING SYSTEM</b>	<b>6</b>
<b>CHARGING SYSTEM</b>	<b>7</b>
<b>APPENDIX</b>	<b>8</b>

**<https://www.ebooklibonline.com>**

Hello dear friend!

Thank you very much for reading.

Enter the link into your browser.

The full manual is available for immediate download.

**<https://www.ebooklibonline.com>**

## FUEL SYSTEM

<b>FUEL FILTER</b> .....	<b>3-2</b>
<b>COMPONENTS</b> .....	<b>3-2</b>
<b>REMOVAL · INSTALLATION</b> .....	<b>3-3</b>
<b>DISASSEMBLY · INSPECTION · REASSEMBLY</b> .....	<b>3-4</b>
<b>INJECTION NOZZLE</b> .....	<b>3-5</b>
<b>COMPONENTS</b> .....	<b>3-5</b>
<b>REMOVAL · INSTALLATION</b> .....	<b>3-6</b>
<b>INJECTION PUMP</b> .....	<b>3-9</b>
<b>SPECIFICATIONS</b> .....	<b>3-9</b>
<b>COMPONENTS</b> .....	<b>3-9</b>
<b>REMOVAL · INSTALLATION (~2004. 9)</b> .....	<b>3-11</b>
<b>REMOVAL (2004. 9~)</b> .....	<b>3-12A</b>
<b>INSTALLATION (2004. 9~)</b> .....	<b>3-12B</b>
<b>DISASSEMBLY</b> .....	<b>3-13</b>
<b>INSPECTION</b> .....	<b>3-18</b>
<b>REASSEMBLY</b> .....	<b>3-21</b>
<b>AIRTIGHTNESS TEST</b> .....	<b>3-31</b>
<b>ADJUSTMENT</b> .....	<b>3-31</b>

# FUEL FILTER COMPONENTS

2302

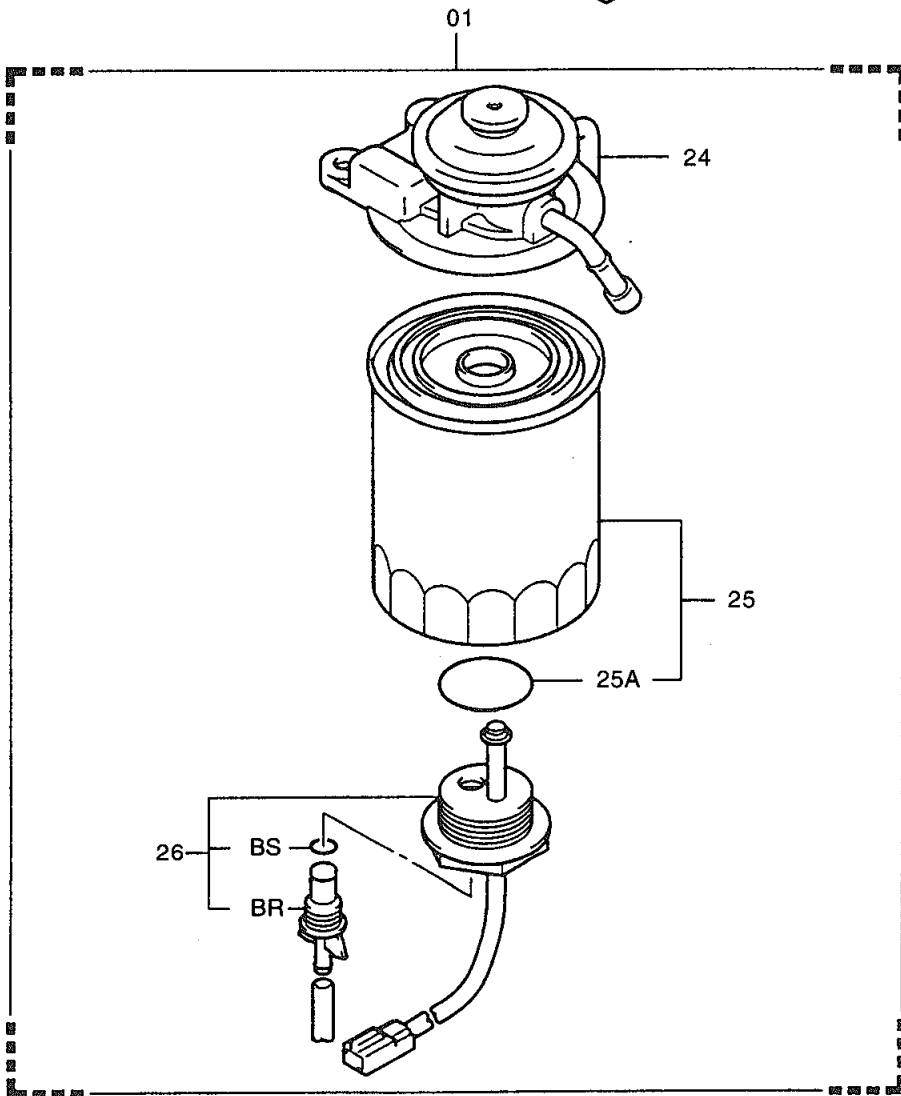
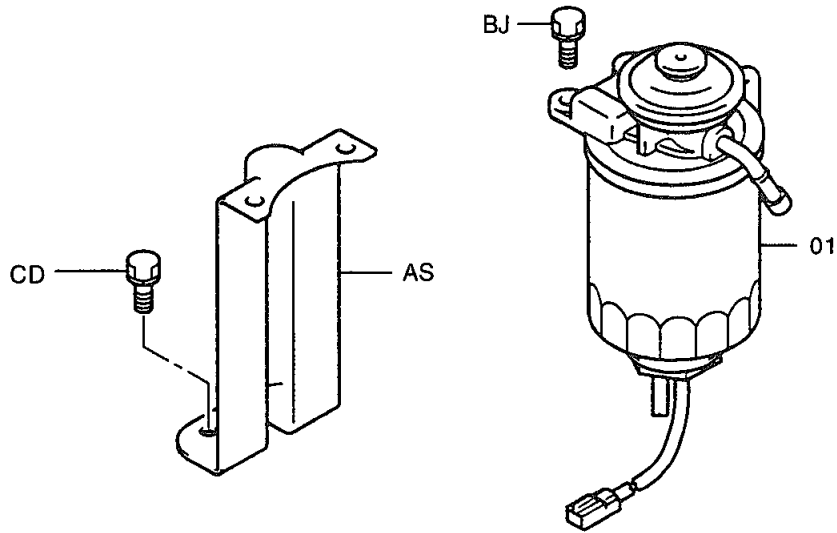

2302-090

## REMOVAL · INSTALLATION

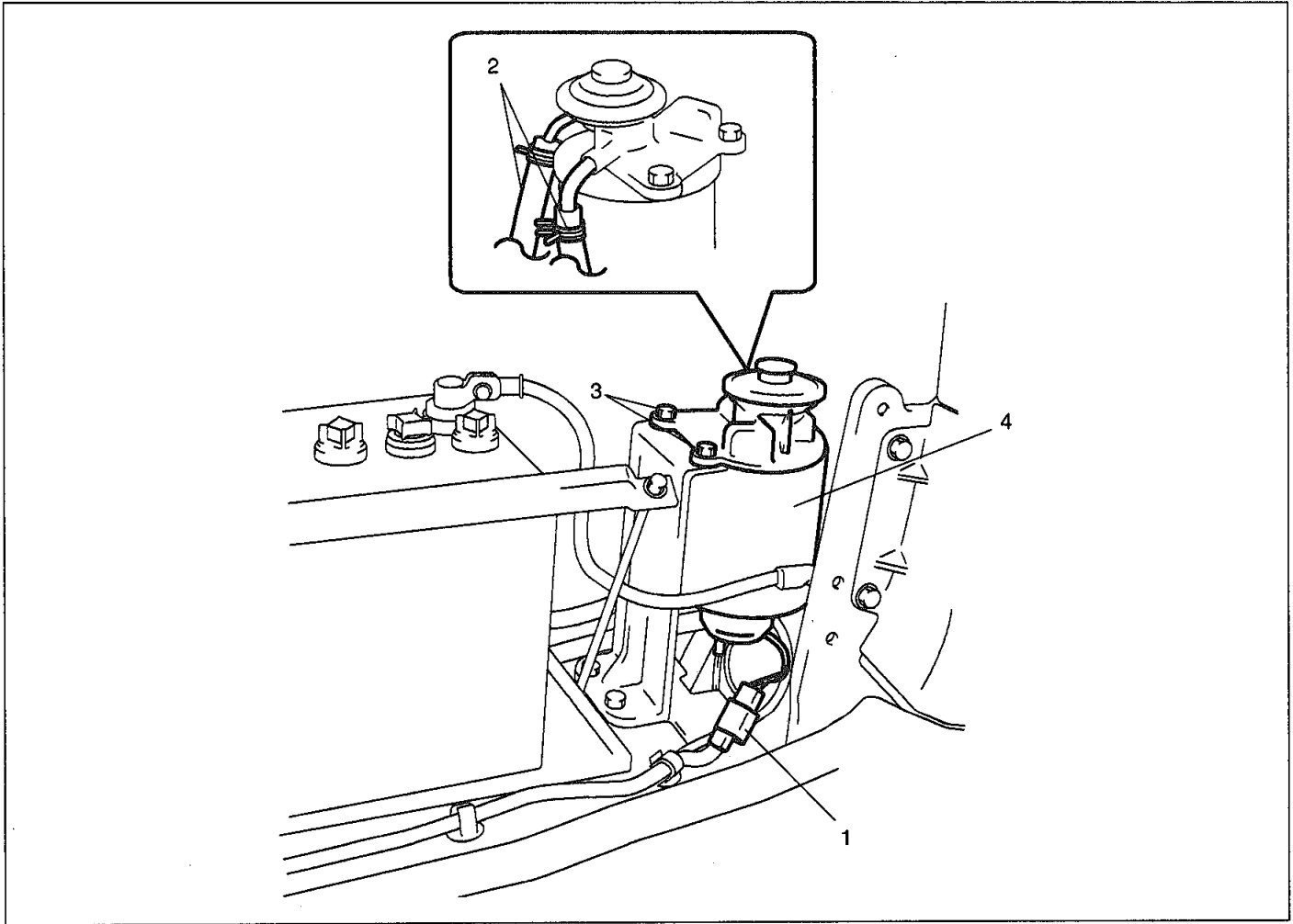

### Removal Procedure

- 1 Disconnect wiring.
- 2 Remove hose clamp and disconnect fuel hose.
- 3 Remove the fuel filter set bolts.
- 4 Remove the fuel filter.

### Installation Procedure

Installation procedure is the reverse of the removal procedure.

### Note:

**Bleed air from the fuel system after install the fuel pump.**

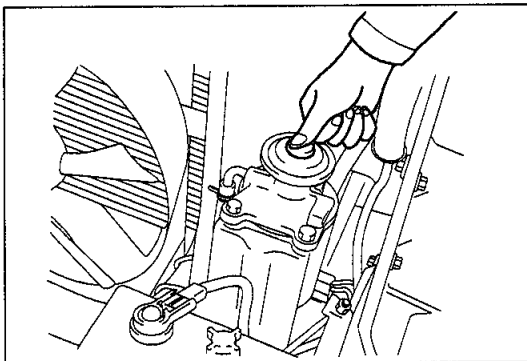

### BLEEDING AIR FROM FUEL SYSTEM

1. Operate the priming pump knob up and down to bleeding air. Bleeding air is the end when the knob movement becomes hard.

**DISASSEMBLY · INSPECTION · REASSEMBLY**

T=N·m (kgf·cm) [ft·lbf]

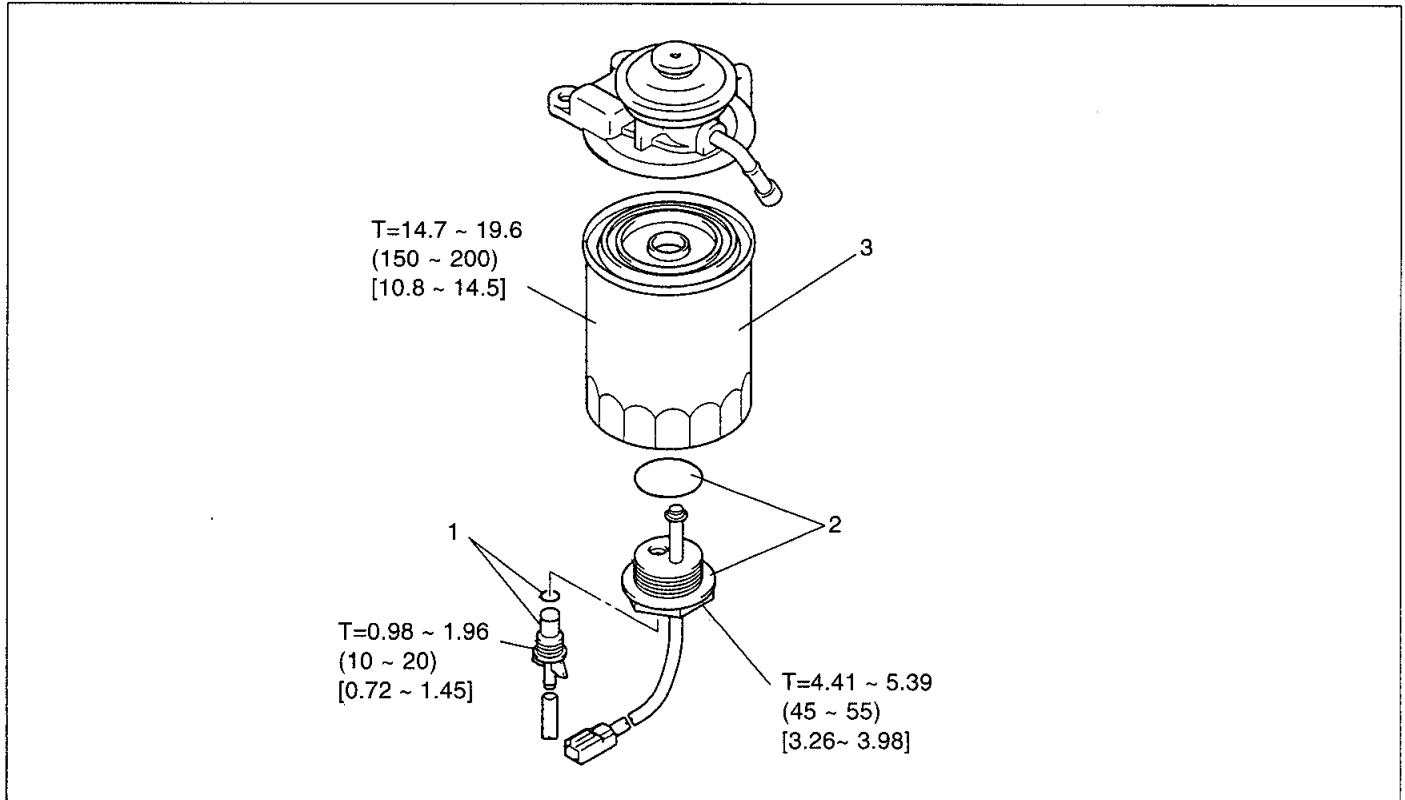
**Disassembly Procedure**

- 1 Remove the drain bolt and O ring.
- 2 Remove the sediment and O ring.
- 3 Remove the fuel filter element. **[Point 1]**

**Reassembly Procedure**

Reassembly procedure is the reverse of the disassembly procedure.

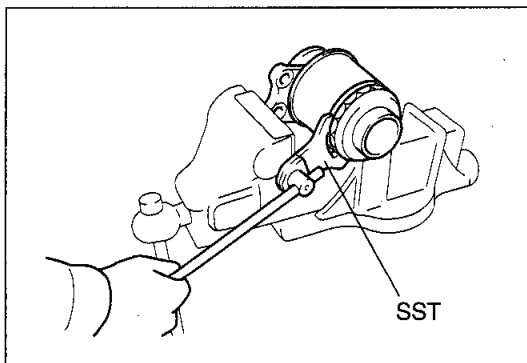
**[Point 1]**

Disassembly · reassembly:

SST 09228-76010-71 (SST 09228-64010)

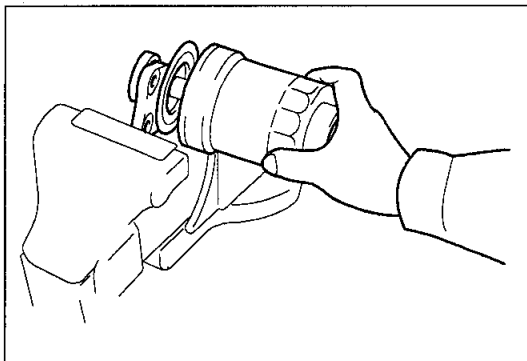
**Reassembly:**

Apply a thin coat of light oil on the O ring of the fuel filter element.

# INJECTION NOZZLE COMPONENTS

2201

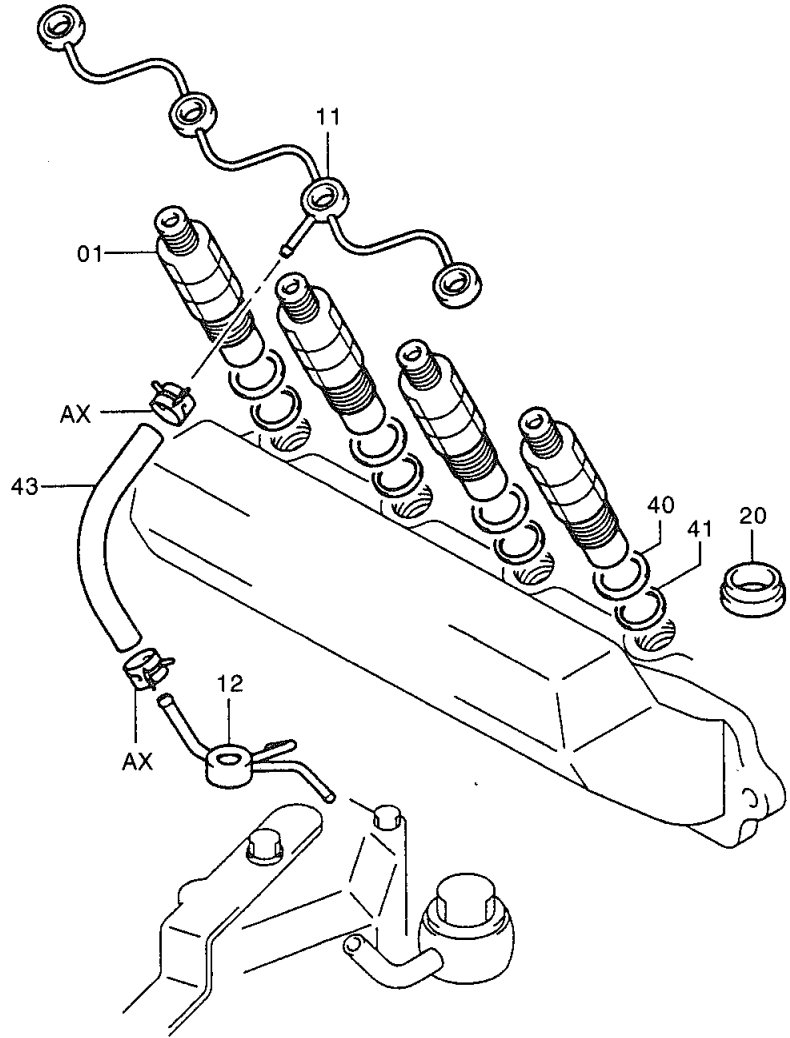
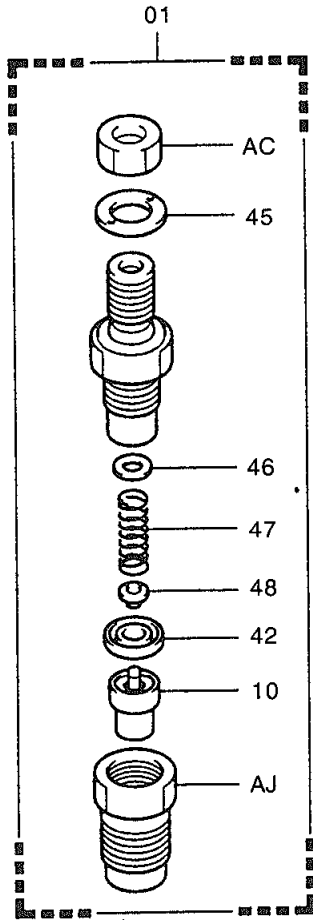

## REMOVAL · INSTALLATION

T=N·m (kg·cm) [ft·lbf]

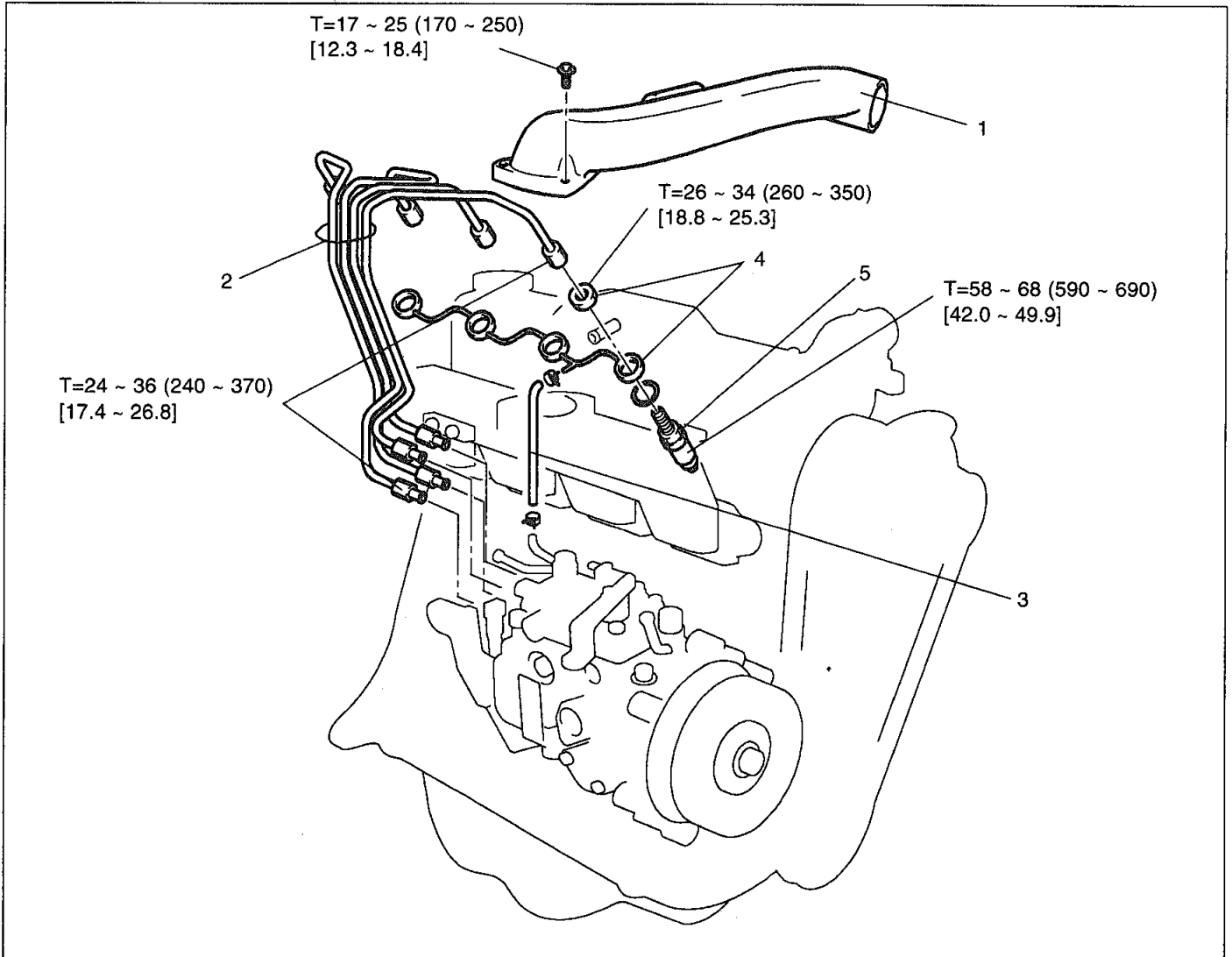
**Removal Procedure**

- 1 Disconnect the intake pipe.
- 2 Disconnect the injection pipe.
- 3 Disconnect the fuel hose between the injection pump and nozzle leakage pipe.
- 4 Disconnect the nozzle linkage pipe.
- 5 Remove the injection nozzle ASSY. **[Point 1]**

**Installation Procedure**

Installation procedure is the reverse of the removal procedure.

**Note:**

**Always renew the nozzle gasket.**

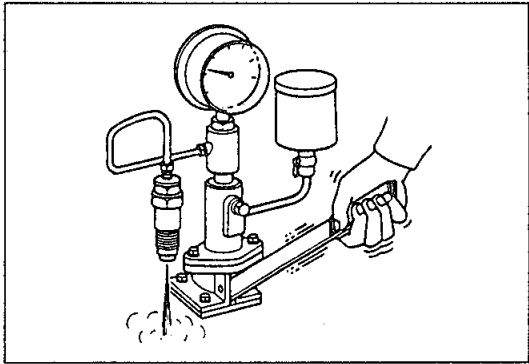

## Point Operation

### [Point 1]

#### Inspection:

Inspect the injection nozzle ASSY.

1. Check the injection nozzle injection pressure.
  - (1) Attach the injection nozzle to the tester.
  - (2) Quickly operate the tester lever to cause a few injections and remove the carbon deposit at the nozzle outlet.
  - (3) Slowly push the tester lever to raise the pressure.
  - (4) Read the pressure gauge immediately when the rising pressure drops suddenly.

**Standard: 11770 ± 490 kPa (120 ± 5 kgf/cm<sup>2</sup>)**  
**[1710 ± 71 psi]**

- (5) If the standard is not met, disassemble the nozzle and adjust by replacing a shim.

If the pressure is outside the standard range, adjust the pressure by selecting a proper washer for setting on top of the pressure spring.

The injection pressure changes by about 490 kPa (5 kgf/cm<sup>2</sup>) [71 psi] as the washer thickness changes by 0.05 mm (0.00197 in.).

43 types of washers are provided in 0.025 mm (0.00098 in.) steps in a range of 0.900 to 1.950 mm (0.0354 to 0.0768 in.).

2. Check oil seal at the valve seat.

- (1) Slowly push the tester lever until the pressure rises to approximately 10 ~ 11 MPa (100 ~ 110 kgf/cm<sup>2</sup>) [1400 ~ 1500 psi]. Maintain the pressure for about 10 seconds, and confirm that the fuel is not leaking from the nozzle outlet or the retaining nut.
- (2) If leaking, disassemble and clean the nozzle or replace it. Check again after replacement.

3. Check the spray pattern.

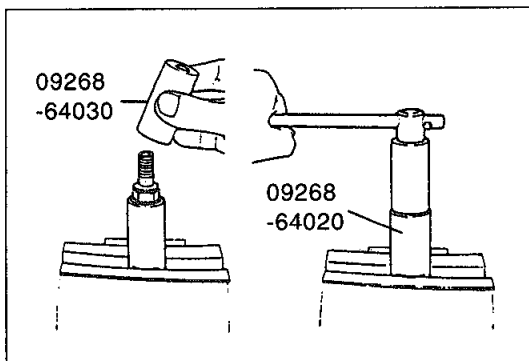
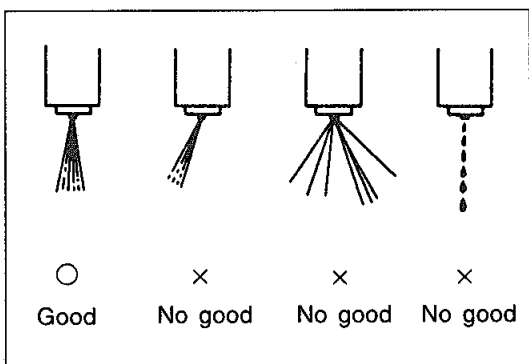
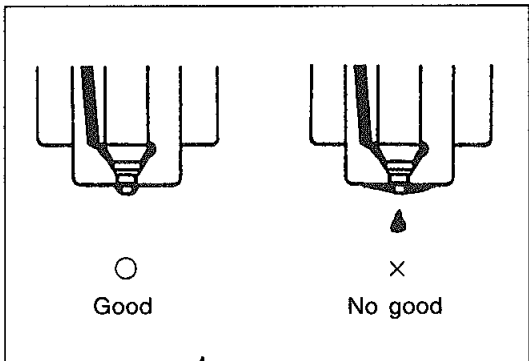
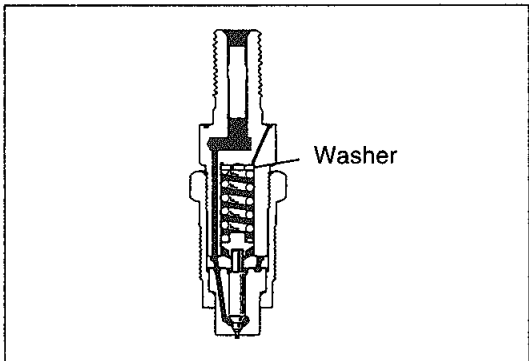

#### Inspection:

Disassemble, clean, and check the injection nozzle ASSY.

1. Secure the nozzle holder by way of a cushioning metal in a vise and remove the retaining nut.

Be careful at this time that the spring inside is active. Note also that the removal of the retaining nut will allow all other parts to be taken apart.

SST 09268-76003-71 (SST 09268-64010)

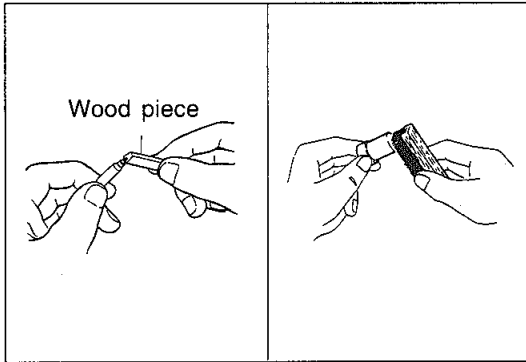

## 2. Clean the nozzle.

- (1) Use a small piece of hard wood and brass brush.  
Clean the nozzle with clean light oil.
- (2) Clean the carbon deposit at the nozzle needle tip using a small piece of hard wood.
- (3) Clean the carbon deposit on the outside of the nozzle body using a brass brush.

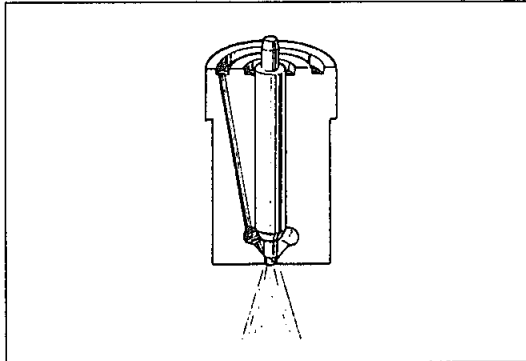

## 3. Check the nozzle appearance.

- (1) Check the nozzle body for cracks and corrosion.
- (2) Check the nozzle needle for damage and corrosion.  
If necessary, replace the nozzle ASSY.

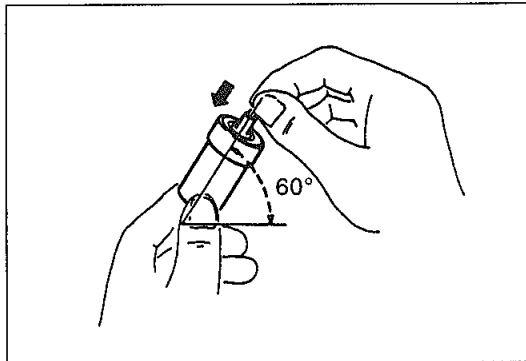

## 4. Perform a sinking test.

- (1) Wash the nozzle needle with clean light oil.
- (2) Incline the nozzle body by about 60°, and expose about 1/3 of the needle.

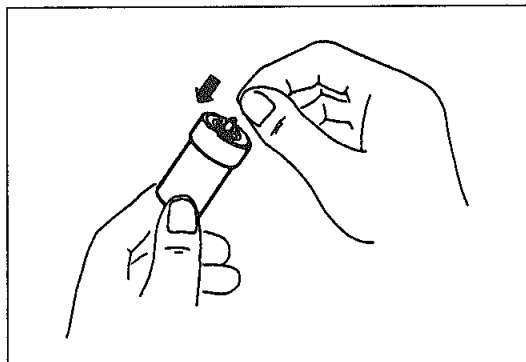

- (3) Release the needle, and check that it sinks smoothly into the body by its own weight.
- (4) Repeat the test while rotating the needle a little at a time.  
If the needle does not sink at any point in the test, replace the body and needle as a set.

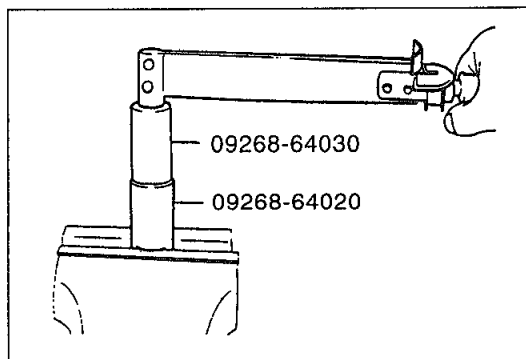

## 5. The installation procedure is the reverse of the removal procedure.

SST 09268-76003-71 (SST 09268-64010)

Retaining nut tightening torque

T=58.8 ~ 78.5 N·m (600 ~ 800 kgf·cm) [43.4 ~ 57.9 ft·lbf]

# INJECTION PUMP

## SPECIFICATIONS

Direction of rotation	Clockwise as viewed from the drive side
Order of injection	A-B-C-D
Injection interval	90° ± 30'
Plunger diameter	10 mm (0.39 in.)
Cam lift	2.2mm (0.087 in.)
Governor type	Mechanical (all speed)
Timer	Hydraulic (with a load sensing timer)
Feed pump	Vane type (built-in type)
Lubrication method	Fuel lubrication
Fuel cut	Fuel cut by a solenoid

## COMPONENTS

2202

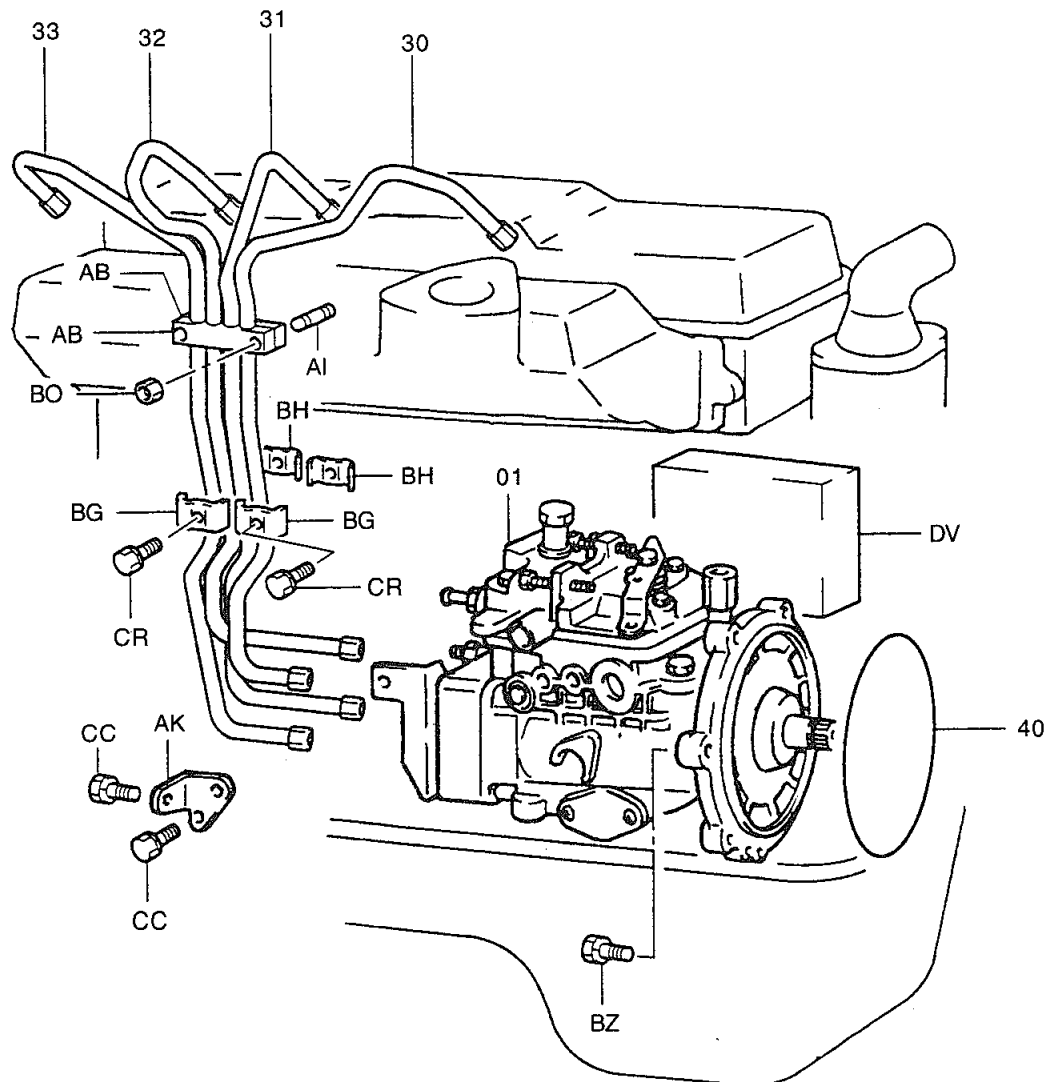

2202-068

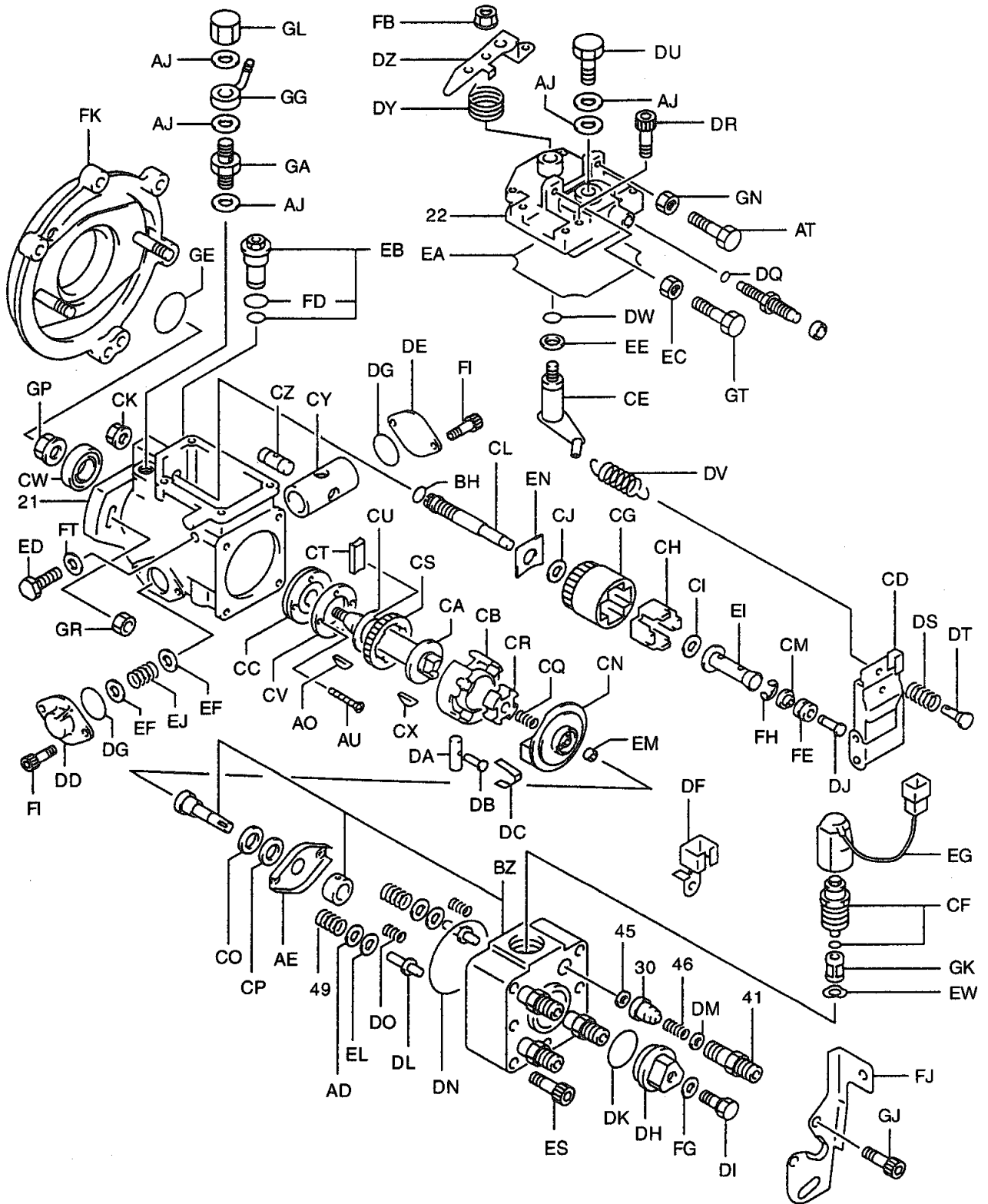

## REMOVAL · INSTALLATION (~2004. 9)

T=N·m (kgf·cm) [ft·lbf]

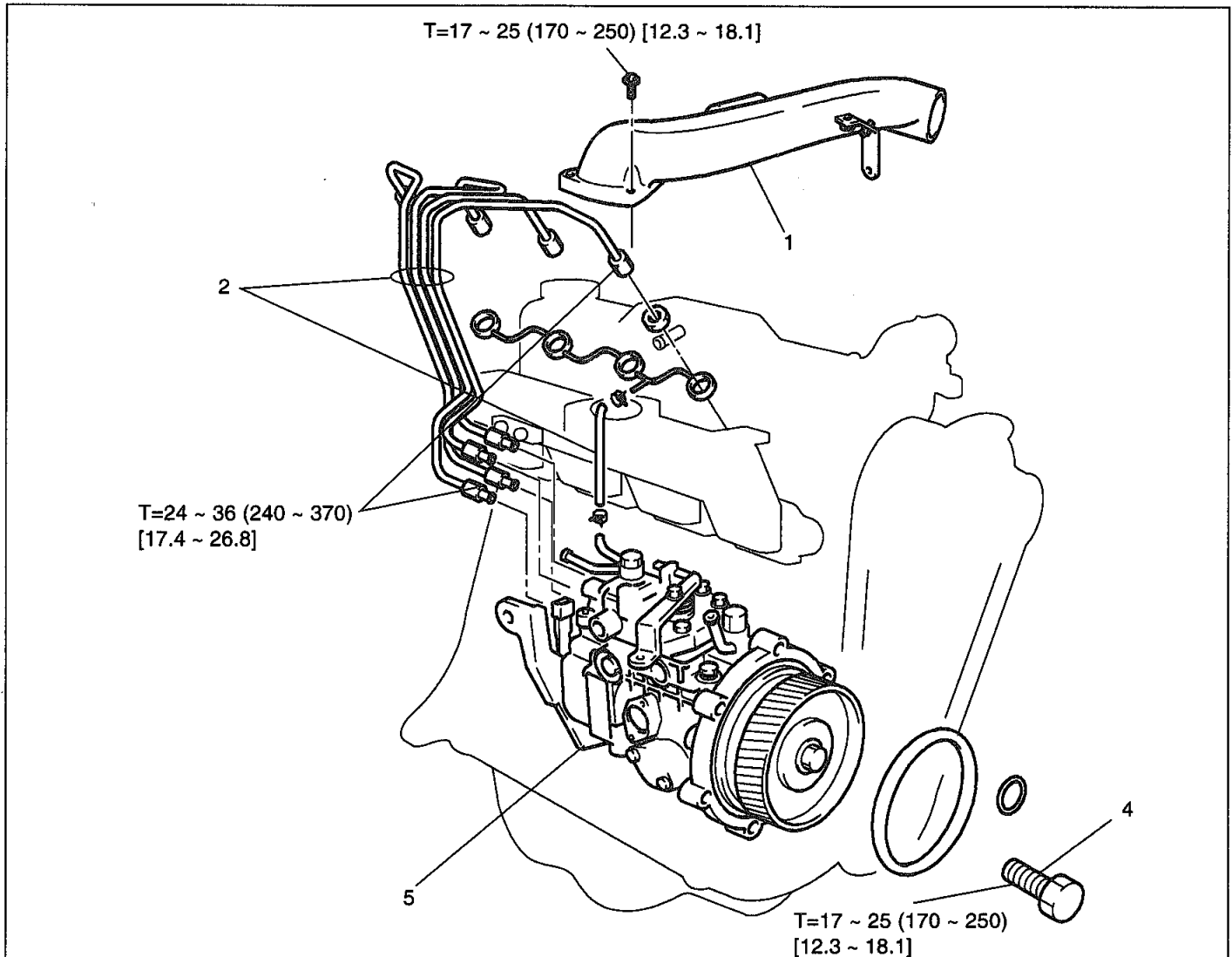
**Removal Procedure**

- 1 Remove the intake pipe.
- 2 Remove the injection pipe and hose.
- 3 Put the match mark on the injection pump drive gear. **[Point 1]**
- 4 Remove the injection pump set bolt.
- 5 Remove the injection pump ASSY W/ drive gear. **[Point 2]**

**Installation Procedure**

Installation procedure is the reverse of the removal procedure.

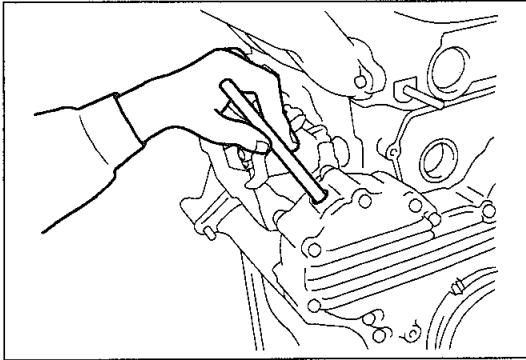

## Point Operations

### [Point 1]

#### Removal:

When no. 1 cylinder is at TDC, the injection pump cam is in the lifted position, which makes the job hard. To make the job easier, return the cylinder slightly back (about 30° ) from TDC.

Remove the timing gear cover bolt and put a matching mark using a white paint or similar device.

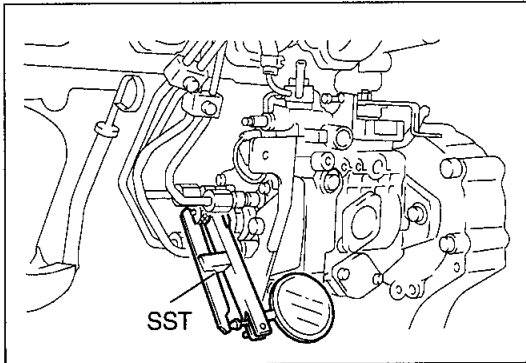

#### Installation:

After the injection pump has been reinstalled, check and adjust the injection timing. (See page on 1-5.)

SST 09240-32880-71

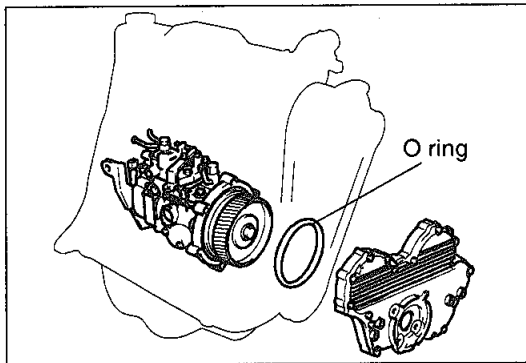

### [Point 2]

#### Installation:

Apply a thin coat of MP grease to the O ring.

#### Installation:

At installation, ensure that the matching mark put during removal is visible through the hole in the timing gear case.

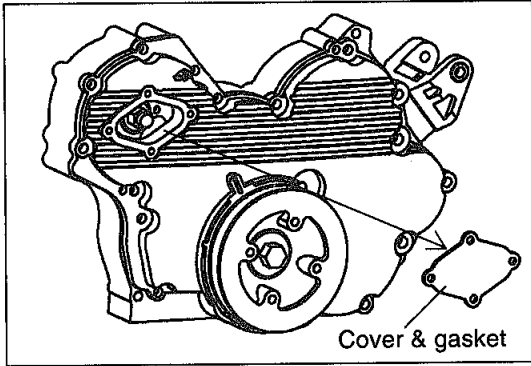

### REMOVAL (2004. 9~)

1. Remove the injection pipe and hose.
2. Remove the service cover on the front of the timing gear cover.
  - (1) Set bolts
  - (2) Cover
  - (3) Gasket

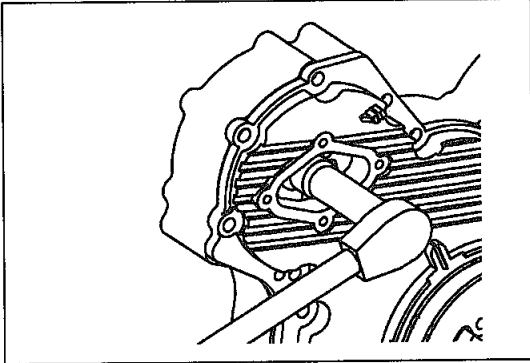

3. Remove the injection pump drive gear set nut while holding the crankshaft.

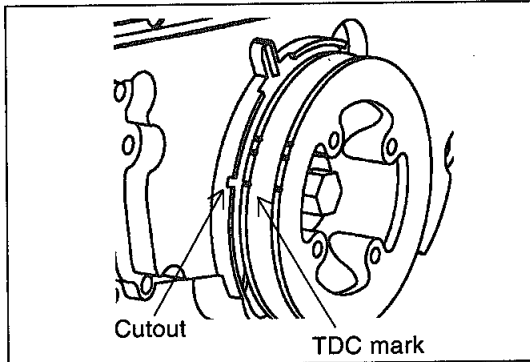

4. Align the TDC mark on the crank pulley with the cutout on the timing gear cover.

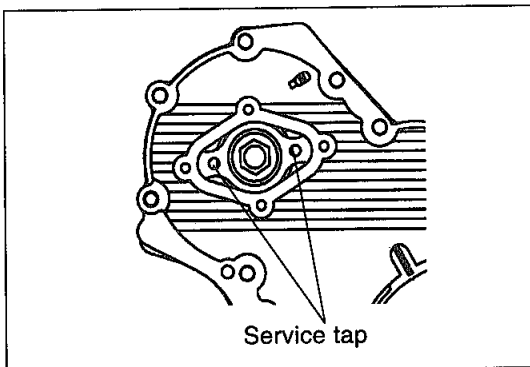

#### Note:

The service tap holes for pump drive gear removal can be seen through the service hole when the TDC mark and the cutout on the timing gear cover are aligned.

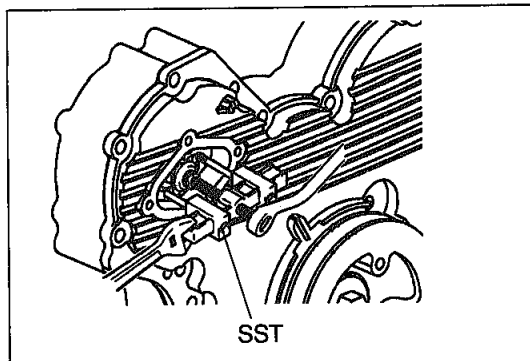

5. Using SST, remove the injection pump drive gear from the pump.
  - SST 09950-76003-71
  - (SST 09950-50012)

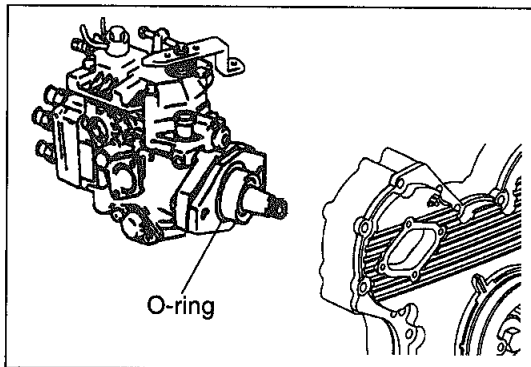

#### 6. Remove the injection pump ASSY.

- (1) Pump stay bolt
- (2) Pump set nuts
- (3) Injection pump ASSY
- (4) O-ring

#### Note:

- Do not turn the crankshaft after removing the injection pump.
- Check the pump shaft key position after removing the injection pump.

### INSTALLATION (2004. 9~)

Installation procedure is the reverse of the removal procedure.

#### Note:

- When installing the injection pump, make sure that the pump shaft key is in the same position as before it was removed.
- Apply a light coat of MP grease to the O-ring.
- Be sure to use a new gasket for the service cover on the front of the timing gear cover.
- Be sure to inspect and adjust the injection timing after installation. (See page 1-5.)
- The tightening torque for each part is as follows:
  - Injection pump drive gear set nut:  $T=56 \sim 72 \text{ N}\cdot\text{m}$  (570 ~ 730 kgf-cm) [41.2 ~ 52.8 ft-lbf]
  - Injection pump set nuts:  $T=56 \sim 72 \text{ N}\cdot\text{m}$  (570 ~ 730 kgf-cm) [41.2 ~ 52.8 ft-lbf]
  - Service cover set bolts:  $T=8.8 \sim 16.3 \text{ N}\cdot\text{m}$  (90 ~ 166 kgf-cm) [6.5 ~ 12.0 ft-lbf]
  - Injection pump pipe:  $T=24 \sim 36 \text{ N}\cdot\text{m}$  (240 ~ 370 kgf-cm) [17.4 ~ 26.8 ft-lbf]

## DISASSEMBLY

### Notes:

- Overhauling and adjustment will be recommended by injection pump repair shop.
- Wash outside of the injection pump. Clean the work bench and workshop for operation.
- Always measure and record the pump injection volume characteristics before disassembly. This information gives a clue as to the cause of any adjustment error or defective parts.
- While disassembling parts, check how they were installed and check them for any sign of deformation, damage, roughening and scratches.
- Arrange the removed parts in an orderly manner and distinguish parts to be renewed from those to the reused.

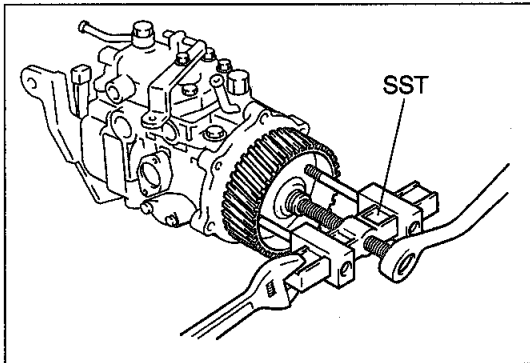

1. Remove the injection pump drive gear. (~2004. 9)
  - (1) Self locking nut
  - (2) Injection pump drive gear  
SST 09950-76003-71 (SST 09950-50012)
  - (3) Injection pump cover
2. Remove the overflow screw and drain fuel.

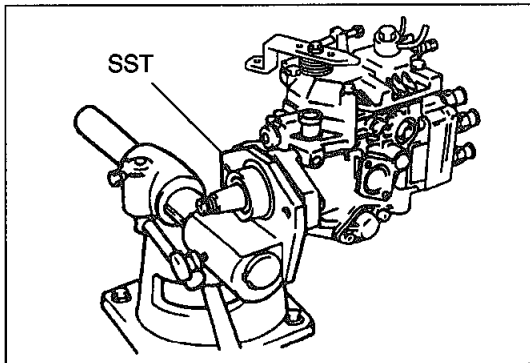

3. Attach the pump using the pump mounting bench.  
SST 09245-76001-71 (SST 09245-54010)

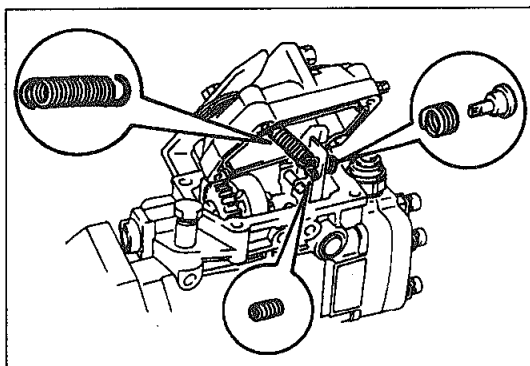

4. Remove the governor cover.
  - (1) Socket bolt
  - (2) Lift the governor cover, and disconnect the control spring from the governor spring seat.
  - (3) Damper spring
  - (4) Governor spring seat
  - (5) Control spring
  - (6) Governor cover

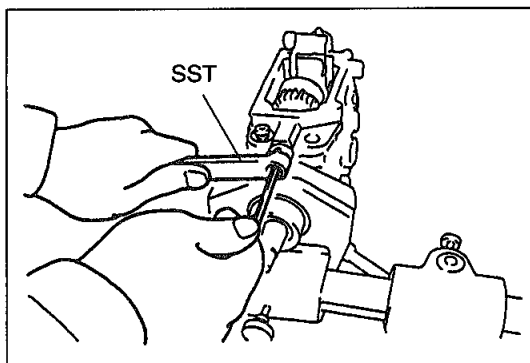

5. Remove the fuel inlet union.
6. Remove the governor shaft parts.
  - (1) Loosen the governor shaft lock nut.  
SST 09260-76003-71 (SST 09260-54012)
  - (2) Loosen the governor shaft using a hexagon wrench.

### Note:

Note that the lock nut and the governor shaft have left-handed threads.



**Suggest:**

**For more complete manuals. Please go to the home page.**

**<https://www.ebooklibonline.com>**

**If the above button click is invalid. Please download this document first, and then click the above link to download the complete manual.**

**Thank you so much for reading**

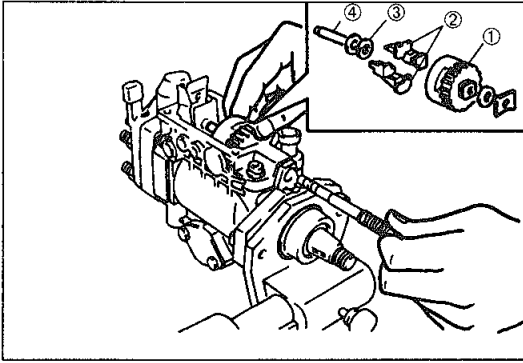

- (3) While extracting the governor shaft, remove the following parts as an ASSY:
- ① Flyweight holder
  - ② Flyweight
  - ③ Flyweight washer
  - ④ Governor sleeve
- (4) Washer  
(5) Adjusting washer

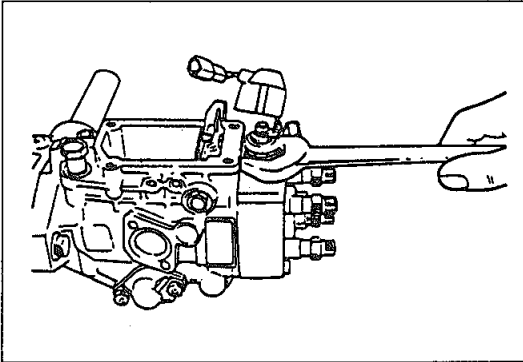

7. Remove the solenoid.
- (1) Boot
  - (2) Solenoid ASSY
  - (3) O ring

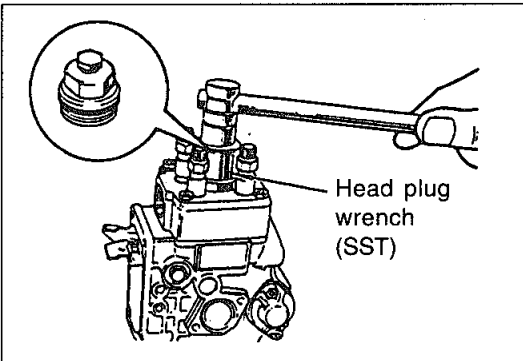

8. Remove the distributor head plug.
- (1) Head plug  
SST 09260-76003-71 (SST 09260-54012)
  - (2) O ring

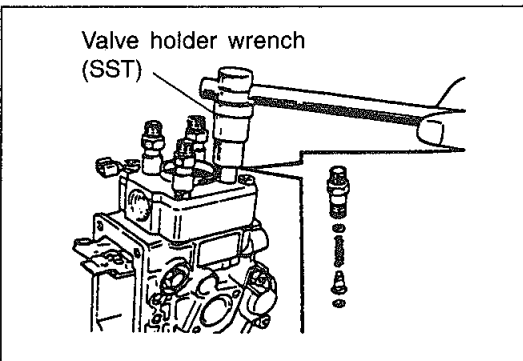

9. Remove the delivery valve.
- (1) Delivery valve holder  
SST 09260-76003-71 (SST 09260-54012)
  - (2) Valve spring seat
  - (3) Valve spring
  - (4) Delivery valve · valve seat
  - (5) Valve gasket

**Notes:**

- Keep removed valves and valve seats in pairs per cylinder.
- Cylinder marks (A, B, C, D) are punched on the distributor heads.
- Keep delivery valves, delivery holders and other parts in groups for reinstallation in the same cylinders.

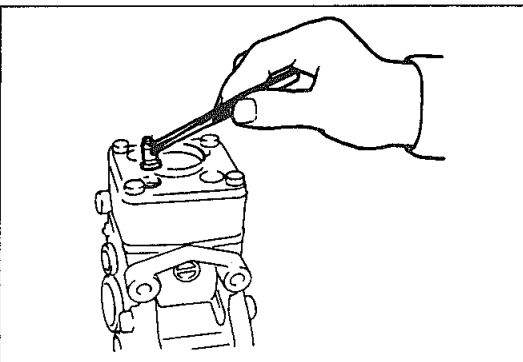

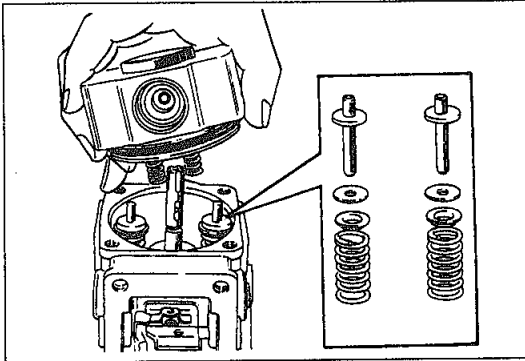

10. Remove the distributor head.

- (1) Distributor head
- (2) Lever support spring

**Note:**

When removing the distributor head, do that carefully while holding the plunger end with a pair of tweezers or similar tool.

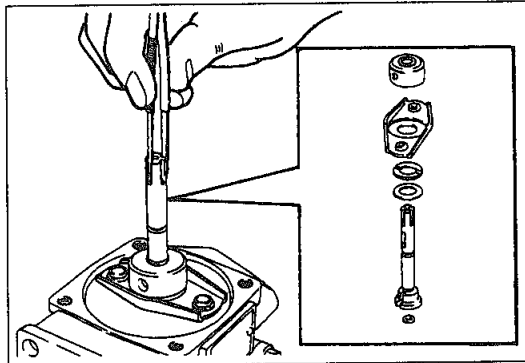

11. Remove the plunger.

- (1) Plunger spring guide
- (2) Plunger spring shim
- (3) Plunger spring upper seat
- (4) Plunger spring
- (5) Spill ring
- (6) Plunger spring lower seat
- (7) Plunger upper plate
- (8) Plunger lower plate
- (9) Plunger

**Note:**

Do not lose adjusting shims under the plunger.

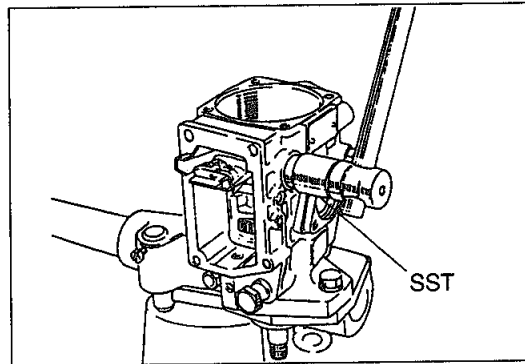

12. Remove the governor lever.

- (1) Supporter bolt  
SST 09260-76003-71 (SST 09260-54012)

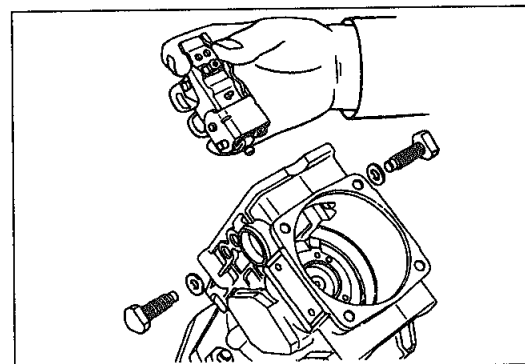

- (2) Governor lever

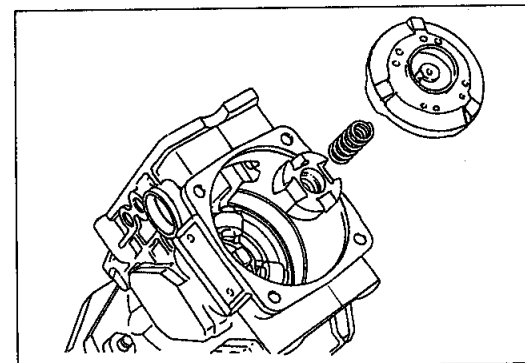

13. Remove the cam plate and coupling.

- (1) Cam plate
- (2) Plunger adjusting shim
- (3) Coupling spring
- (4) Coupling

**<https://www.ebooklibonline.com>**

Hello dear friend!

Thank you very much for reading.

Enter the link into your browser.

The full manual is available for immediate download.

**<https://www.ebooklibonline.com>**