

FGC/FDC33-45

RETURN TO: MAIN INDEX

RETURN TO: SERVICE MANUAL INDEX

GENERAL

ENGINE

TORQUE CONVERTER

DIFFERENTIAL

FRONT AXLE

REAR AXLE

STEERING

BRAKE

BODY

MATERIAL HANDLING SYSTEM

APPENDIX

PREFACE

This manual covers the inspection, adjustment and repair procedures mainly for the overhaul of the engine, chassis and material handling system of the Toyota Forklift FDC33, 35, 40, 45 Series, FGC33, 35, 40, 45 Series.

You are encouraged to read this manual to make the most of the outstanding performance and durability features of these forklifts and to perform proper servicing to maintain them in tip-top running condition.

This repair manual contains the latest information available as of DECEMBER, 1982. For any changes thereafter, you are requested to consult the Toyota Parts and Service News.

The titles of the related repair manuals are as follows:

TOYOTA 2H ENGINE REPAIR MANUAL

TOYOTA 2F ENGINE REPAIR MANUAL

TOYOTA MOTOR CORPORATION

VEHICLE EXTERIOR VIEWS

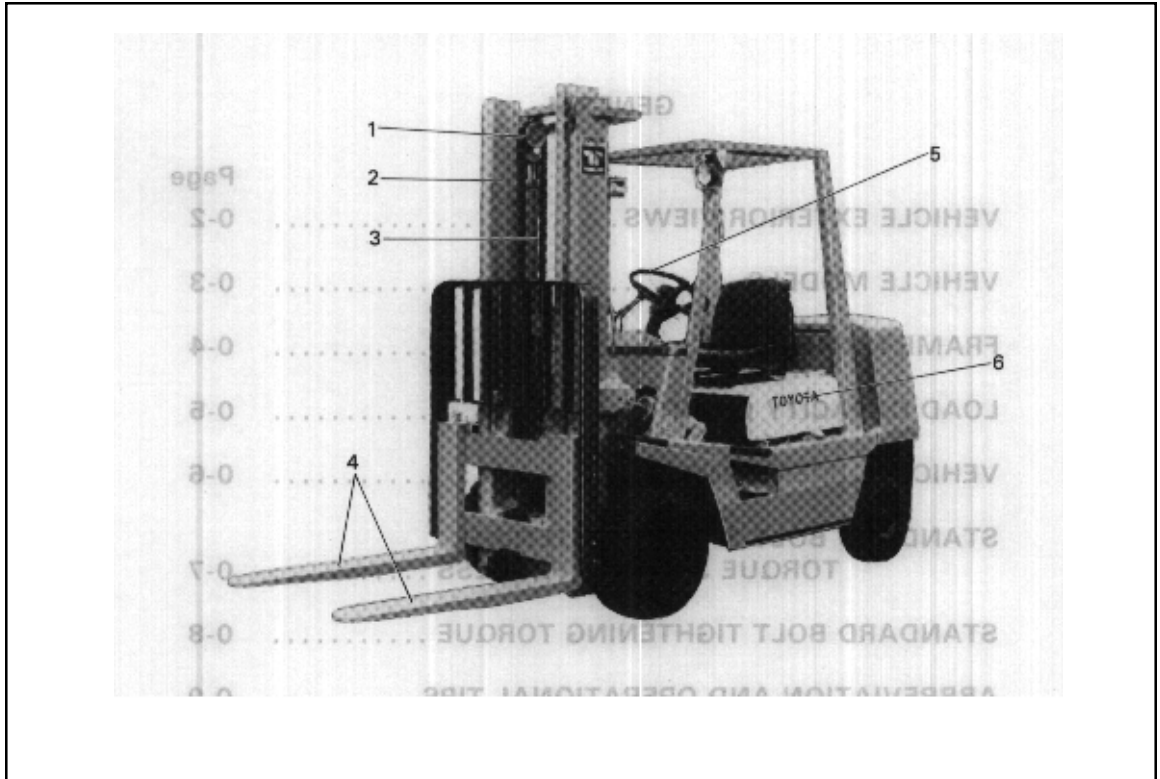
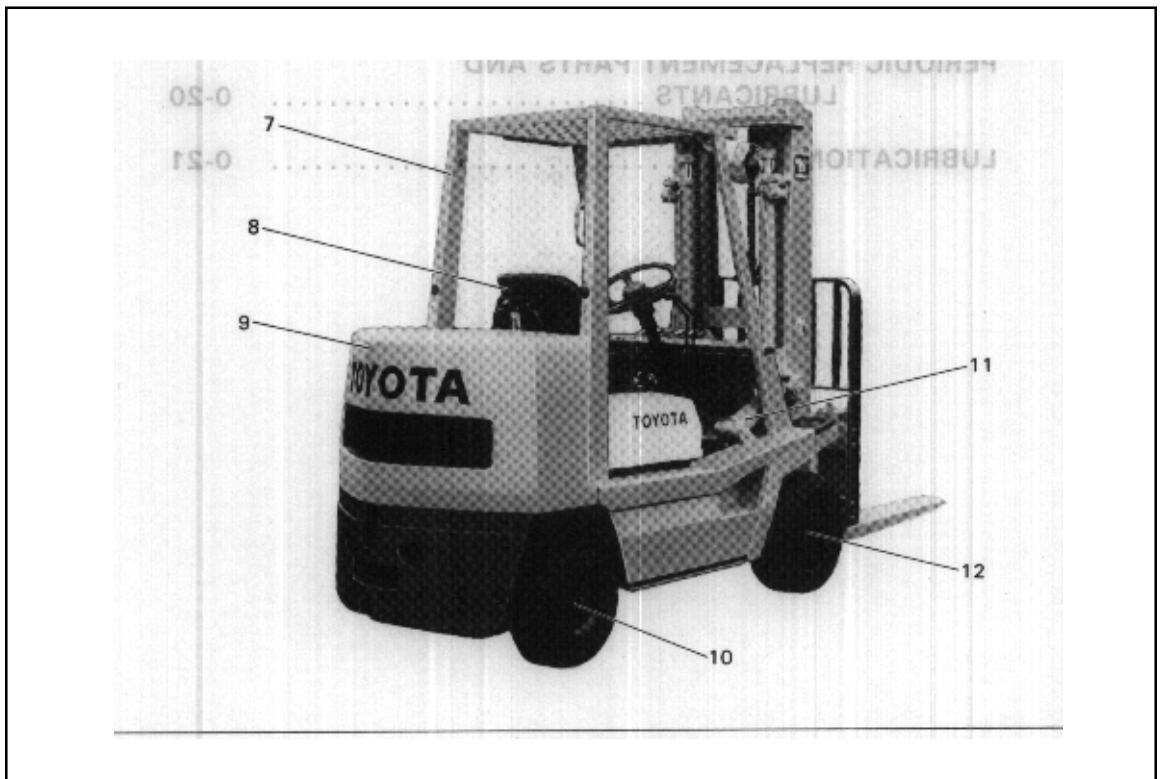

Fig. 0-1 Front view



<https://www.ebooklibonline.com>

Hello dear friend!

Thank you very much for reading.

Enter the link into your browser.

The full manual is available for immediate download.

<https://www.ebooklibonline.com>

VEHICLE MODELS

Load Capacity	Model	Engine	Transmission	Standard UL type	Optional UL type
3500 kg/500 mm 7000 lbs/24 in	FDC33	2H	Torque converter		D, DS
	FGC33	2F	↑	G	GS, LP, LPS
4000 kg/500 mm 8000 lbs/24 in	FDC35	2H	↑		D, DS
	FGC35	2F	↑	G	GS, LP, LPS
4500 kg/500 mm 9000 lbs/24 in	FDC40	2H	↑		D, DS
	FGC40	2F	↑	G	GS, LP, LPS
5000 kg/500 mm 10000 lbs/24 in	FDC45	2H	↑		D, DS
	FGC45	2F	↑	G	GS, LP, LPS

- o Every model is provided with the power steering and power brake as the standard equipment.
- o Every torque converter model is provided with the forward 2-speed and backward 1-speed torque-converter as the standard equipment.

FRAME NUMBER



Fig. 0-3 Location of Frame Number

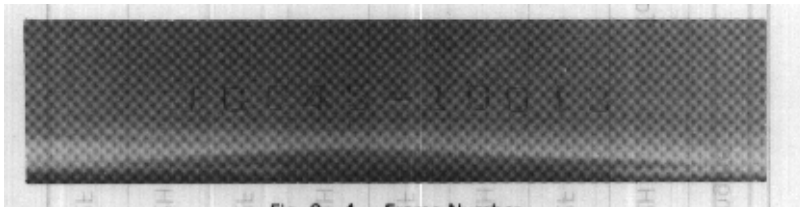
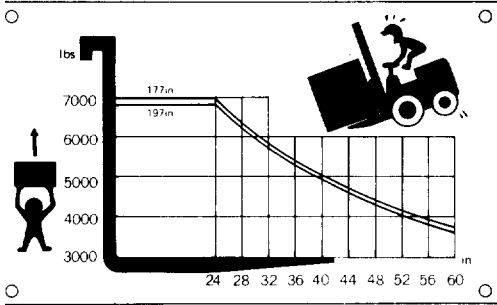

Fig. 0-4 Frame Number

Engine	Model	Frame Number format
2H	FDC33	FDC45— 10001
	FDC35	
	FDC40	
	FDC45	
2F	FGC33	FGC45— 10001
	FGC35	
	FGC40	
	FGC45	

LOAD CAPACITY CHART



FDC 33 FGC 33

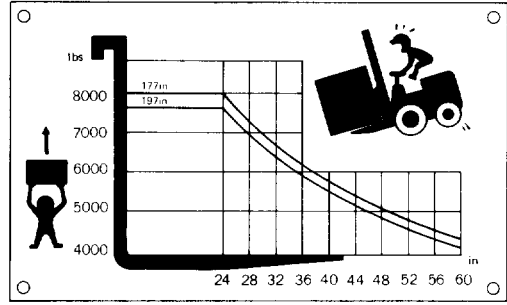

FDC 35 FGC 35

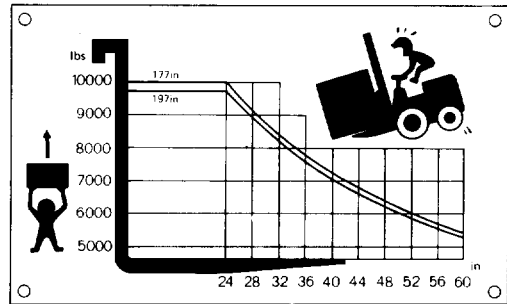
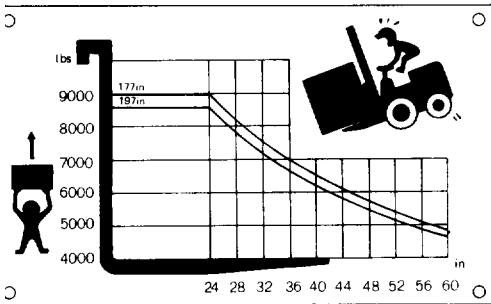

Fig. 0-5 Load capacity chart

VEHICLE DIMENSIONS

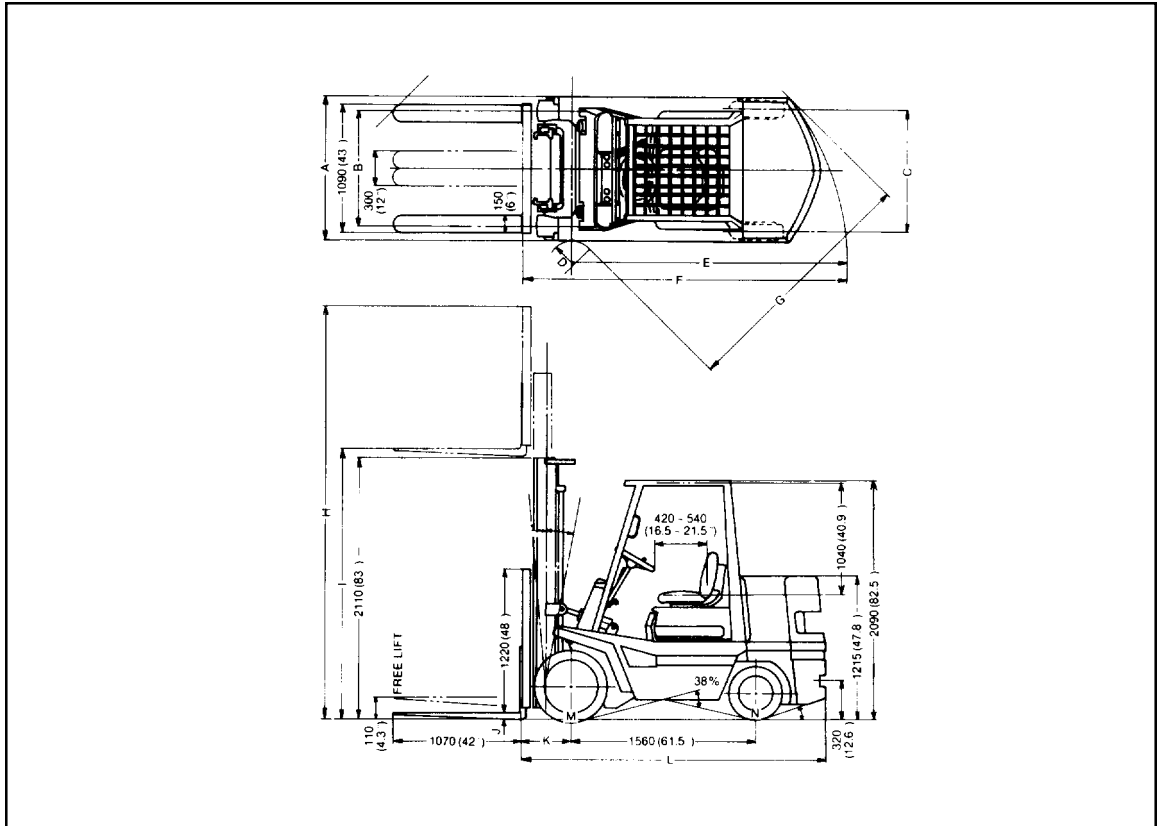

Fig. 0-6 Vehicle dimension







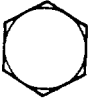

	FDC33, FGC33	FDC35, FGC35	FDC40, FGC40	FDC45, FGC45
A	1,200 mm (47")	←	1,350 mm (53")	←
B	975 mm (38.4")	←	1,045 mm (41.1")	←
C	1,030 mm (40.6")	←	1,055 mm (41.5")	←
D	R 180 mm (7")	←	R 100 (4")	←
E	2,270 mm (89.5")	2,310 mm (91")	2,360 mm (93")	2,410 mm (95")
F	2,720 mm (107")	2,760 mm (108.5")	2,810 (110.5")	2,870 mm (113")
G	2,000 mm (79.5")	2,030 mm (80")	2,110 mm (83")	2,140 mm (84")
H	4,320 mm (170")	←	←	4,220 mm (166")
I	3,100 mm (122")	←	←	3,000 mm (118")
J	50 mm (2")	←	←	55 mm (2.2")
K	450 mm (17.5")	←	←	460 mm (18")
L	2,550 mm (100.5")	2,600 mm (102.5")	2,650 mm (104.5")	2,710 mm (106.5")
M	22 x 9 x 16	←	22 x 12 x 16	←
N	18 x 6 x 12-1/8	←	18 x 7 x 12-1/8	←

STANDARD BOLT & NUT TIGHTENING TORQUE JUDGING PROCESS

Standard bolt and nut tightening torque is not indicated, therefore tightening torque must be judged as below;

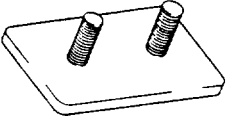
1. Find out the type of the bolt from the list below.
Then, find the bolt tightening torque from the table.
2. The nut tightening torque can be judged from the bolt type. (See the table.)

LIST OF BOLT TYPES AND STRENGTH

	Shape and description		Type
Hexagon bolt		Number in relief or hallmark on the head	4 = 4T 5 = 5T 6 = 6T 7 = 7T
		No mark	4T
		Standard bolt with two relief lines on the head	5T
		Bolt with a brim or a washer and two relief lines on the head	6T
		Three relief lines on the head	7T
Welding bolt			4T
Stud bolt		No mark	4T
		Approximately 2 mm (0.08") hollow on either or both ends	6T
			

Sample number (Hexagon bolt)

9 1 1 1 1 - 4 0 6 1 0

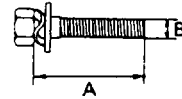
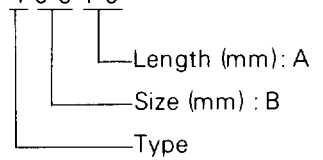

Sample number (Stud bolt)

9 2 1 3 2 - 4 0 6 1 4

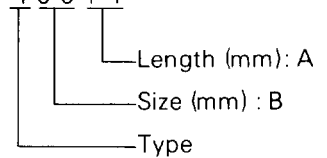

REMOVAL

1. Remove the rear toe board.
 - (1) Set bolts
 - (2) Rear to board



Fig. 1-5 Removing the rear toe board

2. Remove the engine hood.
 - (1) Remove the catch.
 - (2) Disconnect the engine hood stay.
 - (3) Disconnect the seat stay sub-assembly At the seat side.
 - (4) Engine hood hinge set bolts
 - (5) Engine hood (with driver seat)



Fig. 1-6 Removing the engine hood

3. Remove the radiator cover.
 - (1) Set bolts
 - (2) Radiator cover.

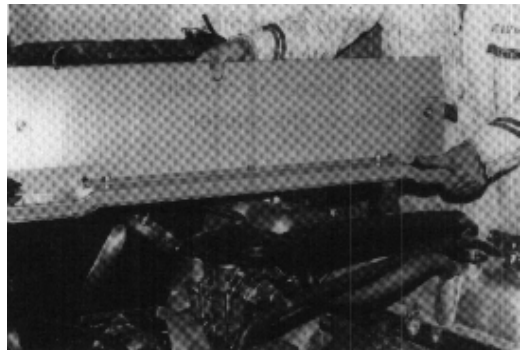

Fig. 1-7 Removing the radiator cover

4. Remove the air cleaner assembly with hose.
 - (1) Set bolts
 - (2) Air cleaner assembly with hose

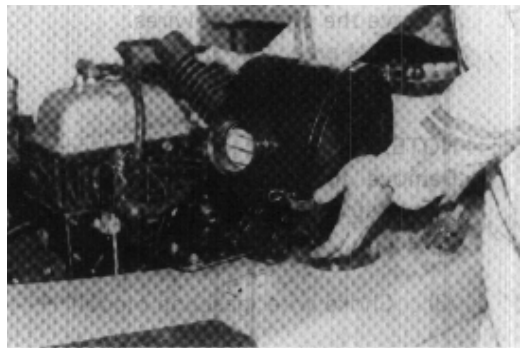

Fig. 1-8 Removing the air cleaner assembly

5. Remove the battery.

- (1) Battery cables
- (2) Battery cap
- (3) Battery
- (4) Set bolts
- (5) Battery case

Cautions:

- **Battery cables must be removed from the negative side first.**
- **2 batteries are used in the diesel model while one battery is used in the gasoline model.**

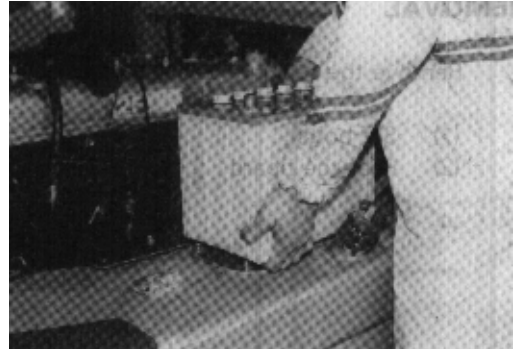

Fig. 1-9 Removing the battery

6. Disconnect the wiring.

- (1) Line to the alternator

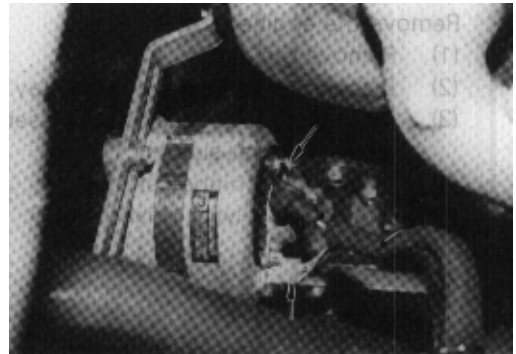

Fig. 1-10 Disconnecting the line to the alternator

- (2) Line to glow plugs (diesel model)
- (3) Line to the distributor and ignition coil (gasoline model)
- (4) Line to the starter

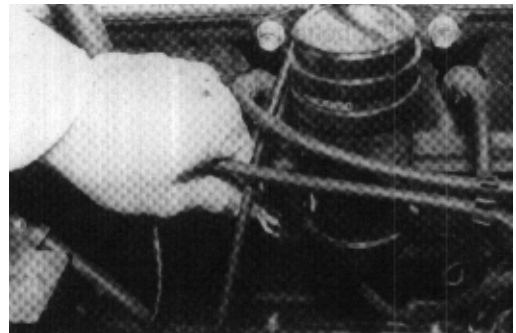

Fig. 1-11 Disconnecting the lines to ignition coil

7. Remove the pipes and wires.

- (1) Fuel pipe
- (2) Accelerator wire

NOTE:

Remove the accelerator wire with the accelerator wire bracket for the diesel model.

- (3) Choke wire (gasoline model)

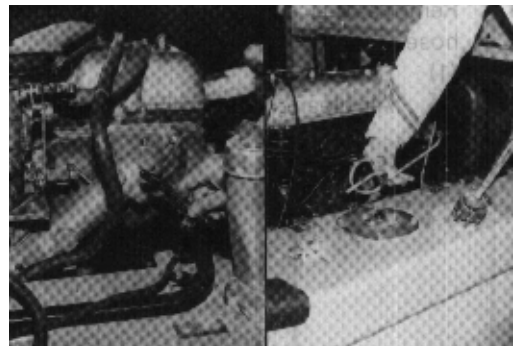

Fig. 1-12 Disconnecting the wire and pipes

8. Drain the coolant.
 - (1) Radiator draining
 - (2) Engine draining

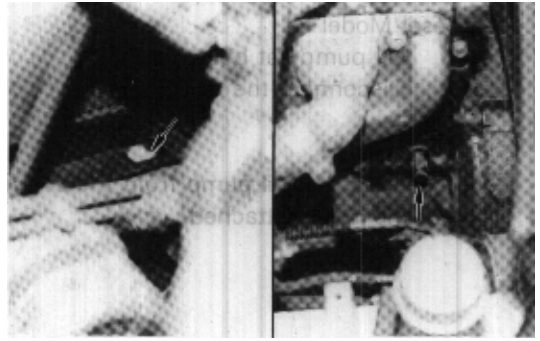

Fig. 1-13 Draining the coolant

9. Remove the balance weight.
 - (1) Put the wire around the balance weight.
 - (2) Set bolts
 - (3) Balance weight

Reference: Weight of balance weight

FDC/FGC33 series Approx. 1,840kg (4048 lb)

FDC/FGC35 series Approx. 2,190kg (4818 lb)

FDC/FGC40 series Approx. 2,510kg (5522 lb)

FDC/FGC45 series Approx. 2,890kg (6358 lb)

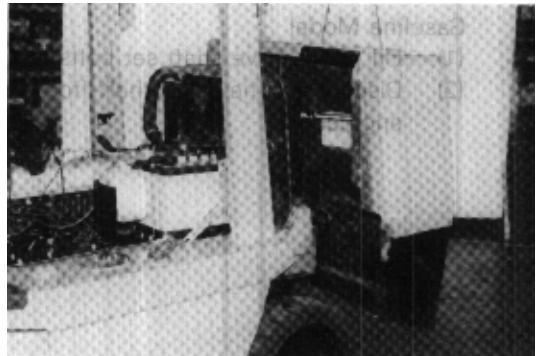

Fig. 1-14 Removing the balance weight

10. Remove the muffler assembly.
 - (1) Exhaust pipe connector
 - (2) Muffler set bolts
 - (3) Muffler assembly



Fig. 1-15 Removing the muffler assembly

11. Remove the radiator assembly and the fan shroud.
 - (1) Disconnect the inlet and outlet hoses.
 - (2) Disconnect the torque converter cooler hoses (2 pcs).
 - (3) Set bolts
 - (4) Radiator assembly, fan shroud



Fig. 1-16 Removing the radiator assembly

12. Disconnect the oil pump.
 Diesel Model
 (1) Oil pump set bolts.
 (2) Disconnect the oil pump.

Note:

Disconnect the oil pump from the engine with the hoses attached.



Fig. 1-17 Disconnecting the oil pump (2H)

Gasoline Model

- (1) Oil pump drive shaft set bolts
 (2) Disconnect the drive shaft from the engine.

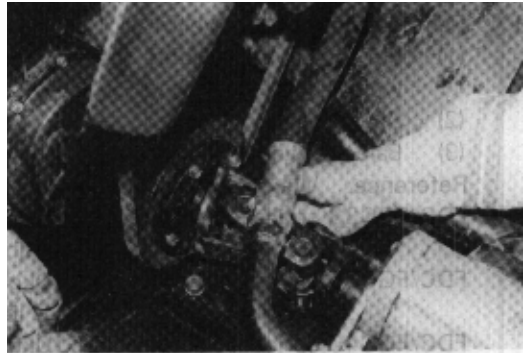

Fig. 1-18 Disconnecting the oil pump drive

13. Remove the fan sub-assy.
 (1) Loosen the fan belt.
 (2) Fan set bolt
 (3) Fan sub-assy



Fig. 1-19 Removing the Fan sub-assy

14. Slightly lift the engine.
 [Using SST]
 For lifting with a hoist
 SST 09010-20110-71
 For lifting with a forklift
 SST 09020-20110-71
 SST 09090-04000

Caution:

SST must be inserted from the back side of the vehicle.

○



Fig. 1-20 Slightly lifting the engine

15. Remove the engine mounting set nuts.

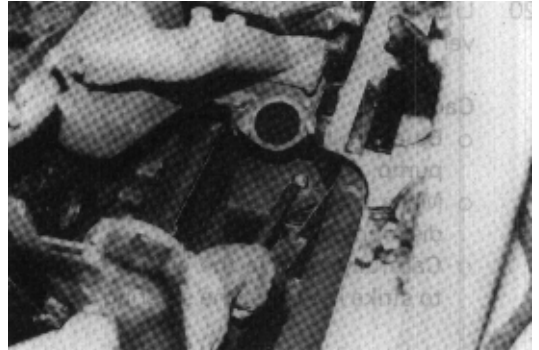

Fig. 1-21 Removing the mounting set nuts

16. Place a stand under the torque converter case.

17. Remove the torque converter case cover.

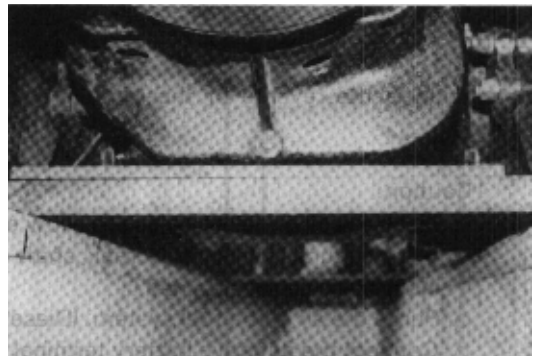

Fig. 1-22 Supporting the torque converter case with a stand

18. Remove the flexible plate set bolts.

(1) Set bolts (6pcs.)

Note:

Turn the crankshaft pulley set bolt when rotating the flywheel.

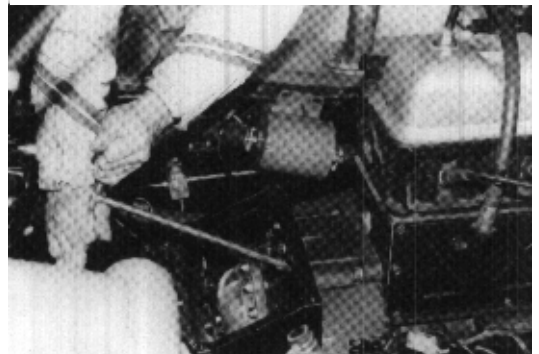

Fig. 1-23 Removing the flexible plate set bolts

19. Disconnect the torque converter and the engine.

(1) Set bolts

(2) Disconnect the torque converter and the engine.

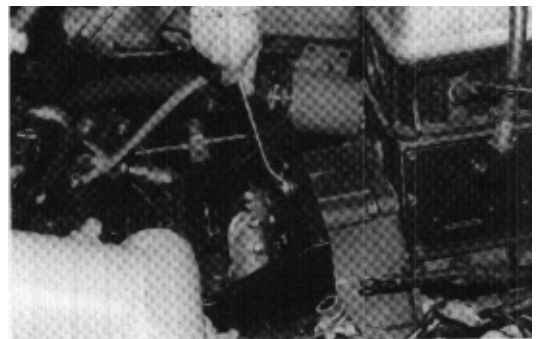

Fig. 1-24 Disconnecting the engine

Lift the engine and remove it from the vehicle.

Caution:

- Be careful so as not to damage the oil pump.
- Make sure that all wires and pipes are disconnected.
- Carefully remove the engine so as not to strike it against the steering wheel.

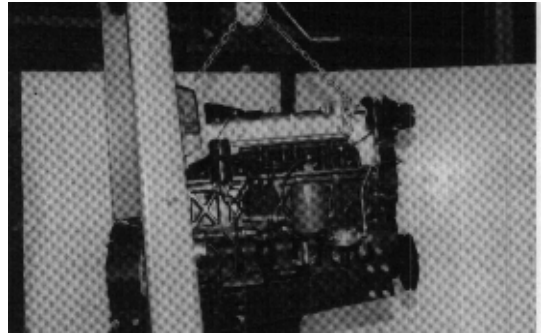

Fig. 1-25 Removing the engine

INSTALLATION

Installation is the reverse of the removal procedure.

Caution:

- Place the oil pump at a place to allow easy installation before fitting the engine. (Diesel model)
- Slightly turn the engine crank shaft when spline alignment with the engine during oil pump installation is not obtained.
- Purge the air in the fuel system. (Diesel model)
- Connect the negative battery terminal after confirming that the electric wiring is correct.
- Check the coolant and engine oil. If insufficient, replenish them before making engine adjustment.

ENGINE ADJUSTMENT (DIESEL MODEL)

1. Idling speed adjustment
 - (1) Warm up the engine.
(Coolant temperature: up to 75 ~ 85°C (167 ~ 135°F).)
 - (2) Set the engine tachometer.

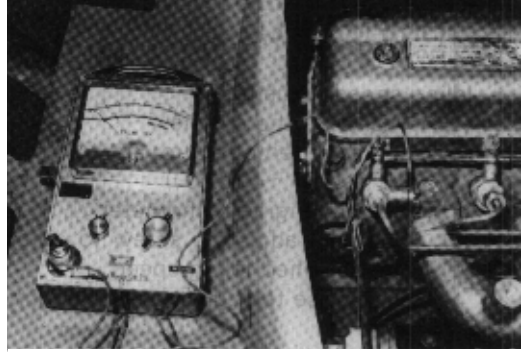

Fig. 1-26 Setting the engine tachometer

- (3) Turn the adjusting screw to obtain the specified idling speed.
Idling speed: 650 ± 50 rpm



Fig. 1-27 Adjusting the idling speed

2. Maximum no-load rpm adjustment
 - (1) Warm up the engine.
 - (2) Set the engine tachometer.
 - (3) Fully depress the accelerator pedal.
 - (4) Turn the adjusting screw to obtain the specified maximum no-load rpm.
Maximum no-load rpm:
2350₀+¹⁰⁰rpm



Fig. 1-28 Adjusting the maximum no-load rpm

3. Operate the material handling levers, and measure the engine rpm for full relief.
Engine rpm down for full relief: Within 250 rpm
If the decrement exceeds 250 rpm, adjust the engine and injection pump.

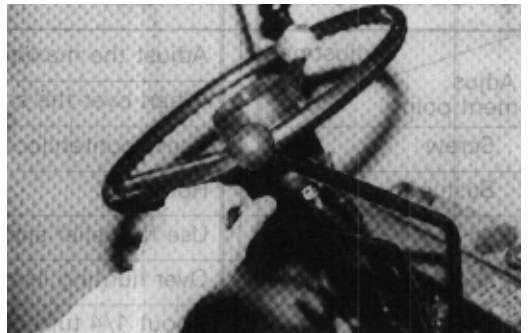

Fig. 1-29 Measuring the engine rpm for full relief

**ENGINE ADJUSTMENT
(GASOLINE MODEL)**

1. Idling speed adjustment
 - (1) Warm up the engine.
(Coolant temperatura: up to 75 ~ 85°C (167 ~ 185°F))
 - (2) Set the engine tachometer.
 - (3) Turn the adjusting screw to obtain the specified idling speed.
Clockwise turn: Increases the idling rpm.
Counterclockwise turn: Decreases the idling rpm.
Idling speed: 650 ± 50 rpm

2. Maximum no-load rpm adjustment
 - (1) Warm up the engine.
 - (2) Set the engine tachometer.
 - (3) Fully depress the accelerator pedal and measure the rpm.
Maximum no-load rpm: 2350 ± 50 rpm
 - (4) Operate the material handling levers, and measure the engine rpm for full relief.
Engine rpm down for full relief:
Within 300 rpm
 - (5) If the measured rpm is not within the specified range, adjust the governor to obtain the most stabilized rpm within the specified range and minimize the decrement for full relief.
Turn the screw with the wrench attached to the cap, and adjust the rpm by turning the bush with the SST.
After adjustment, install and seal the cap.
SST 09010-30150-71

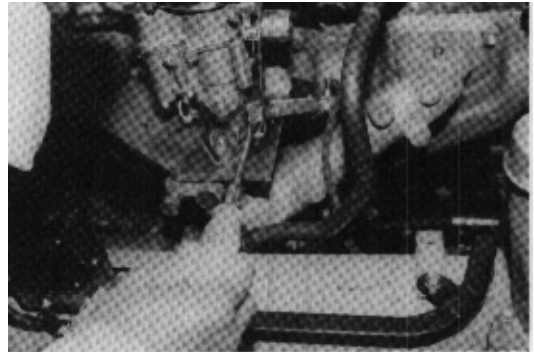

Fig. 1-30 Adjusting the idling speed



Fig. 1-31 Measuring the engine rpm for full relief



Fig. 1-32 Adjusting the air governor

AIR GOVERNOR ADJUSTMENT

Adjustment point	Adjustment	Adjust the maximum no-load rpm to the specified level.	
		When over the specified rpm	When under the specified rpm
Screw		Turn counterclockwise	Hold
Bushing		Hold	Turn counterclockwise
Adjustment location	Adjustment	Use full relief and check for hunting	
		Over hunting level	Under hunting level
Screw		About 1/4 turn clockwise	Turn clockwise
Bushing		Turn counterclockwise	About 1/4 turn clockwise

ACCELERATOR PEDAL

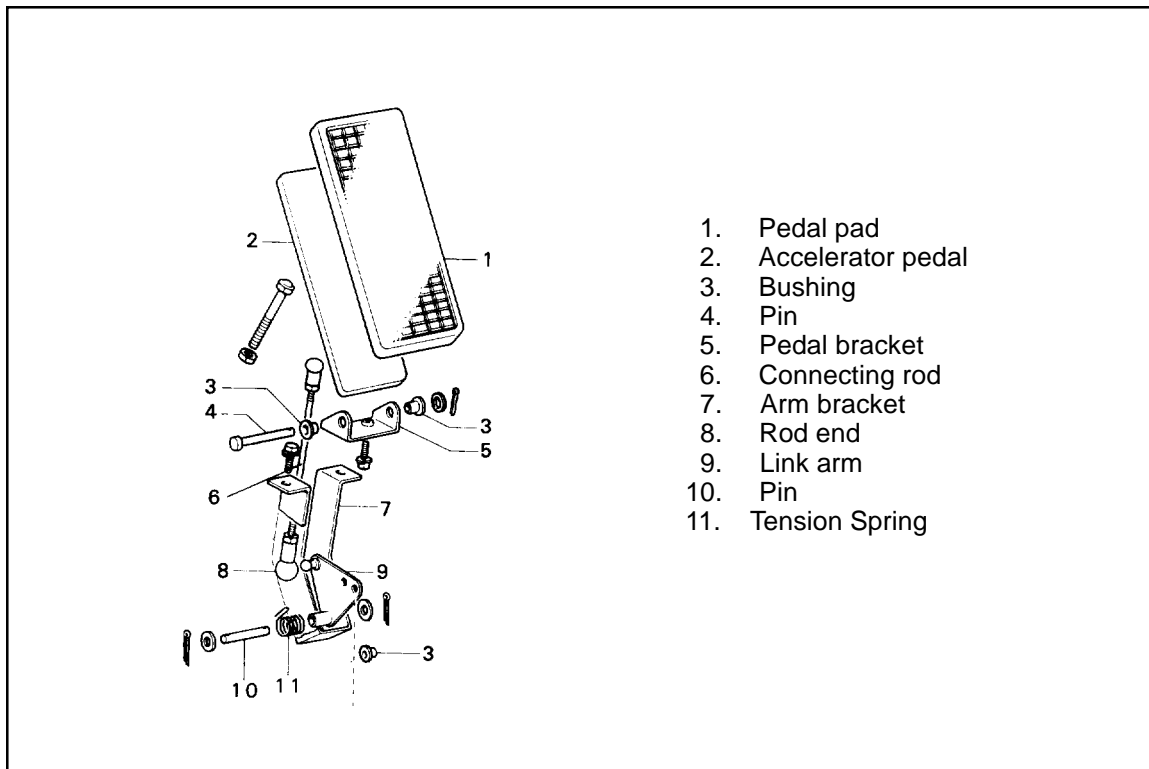

Fig. 1-33 Accelerator pedal components

ACCELERATOR PEDAL ADJUSTMENT

1. Adjust the length of connecting rod (1) to obtain the following height of the accelerator pedal:
 Accelerator pedal height: 128mm (5.0 in.)
 (from the pad top end to the toe board)
2. Adjust the height of stopper bolt (2).
 (1) Gradually depress the accelerator pedal. When the engine side link first comes into contact with the stopper, adjust the clearance between stopper bolt (2) and the pedal (so that excessive wire elongation or link flexure will not occur).
 (2) Lock the lock nut (3).

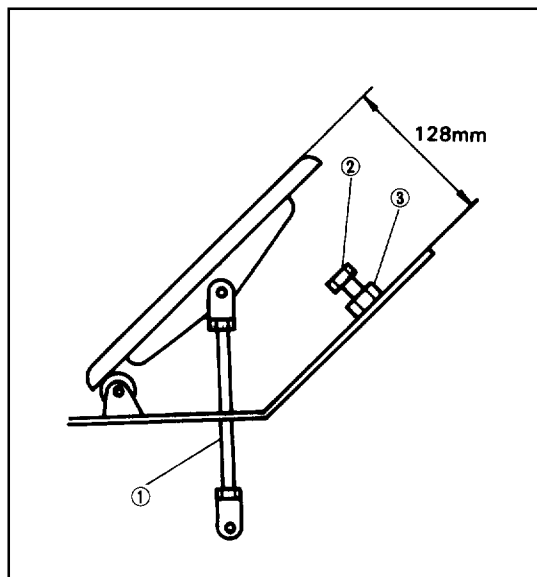

Fig. 1-42 Adjusting the Accelerator pedal height

AIR CLEANER

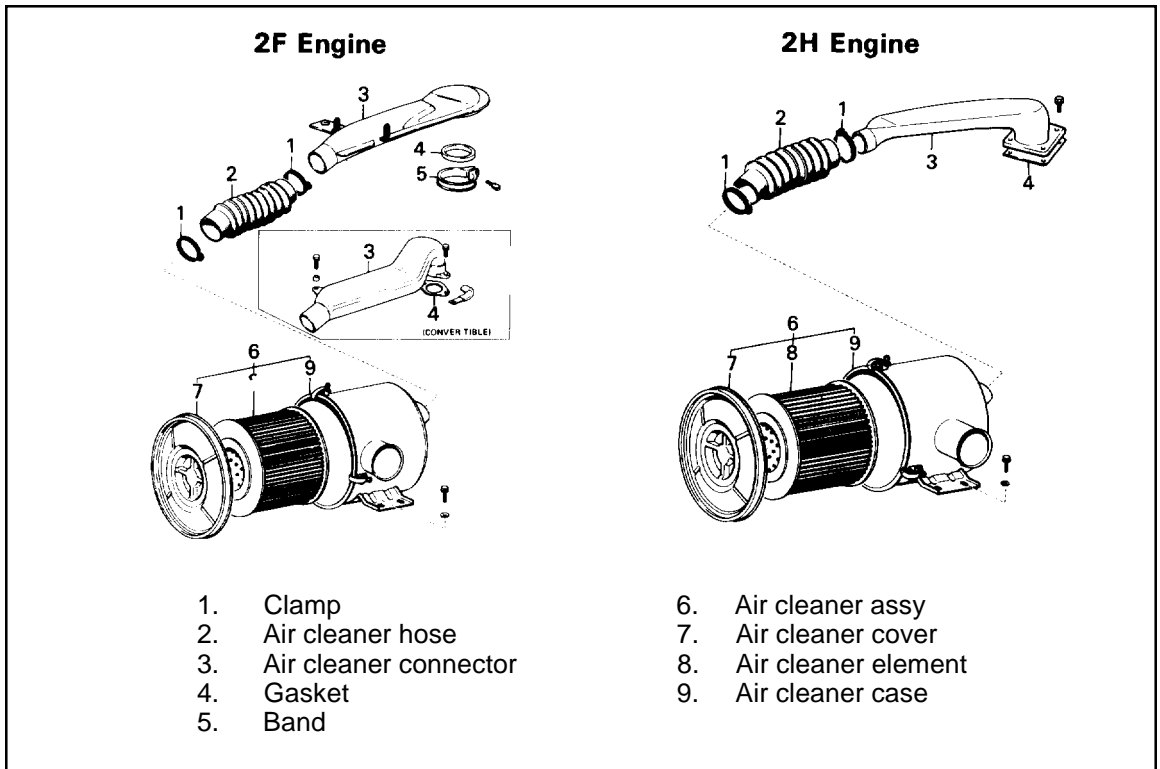

Fig. 1-35 Air cleaner components

INSPECTION AND CLEANING

1. Open the engine hood.
2. Remove the air cleaner cover and take out the element.
3. Inspect and clean the element.
 - (1) Damage and deformation of pleats
 - (2) Clean the element with compressed air.

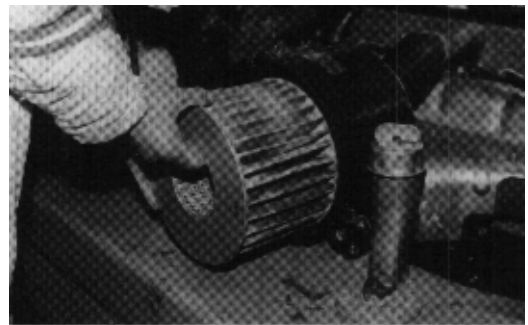

Fig. 1-36 Removing the air cleaner

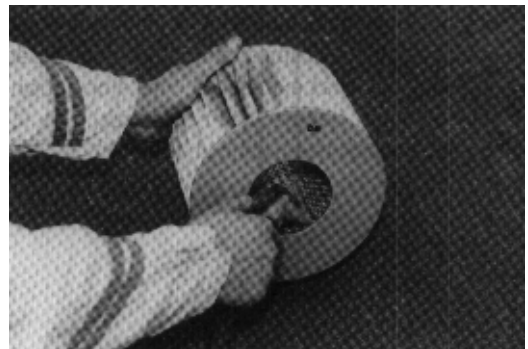
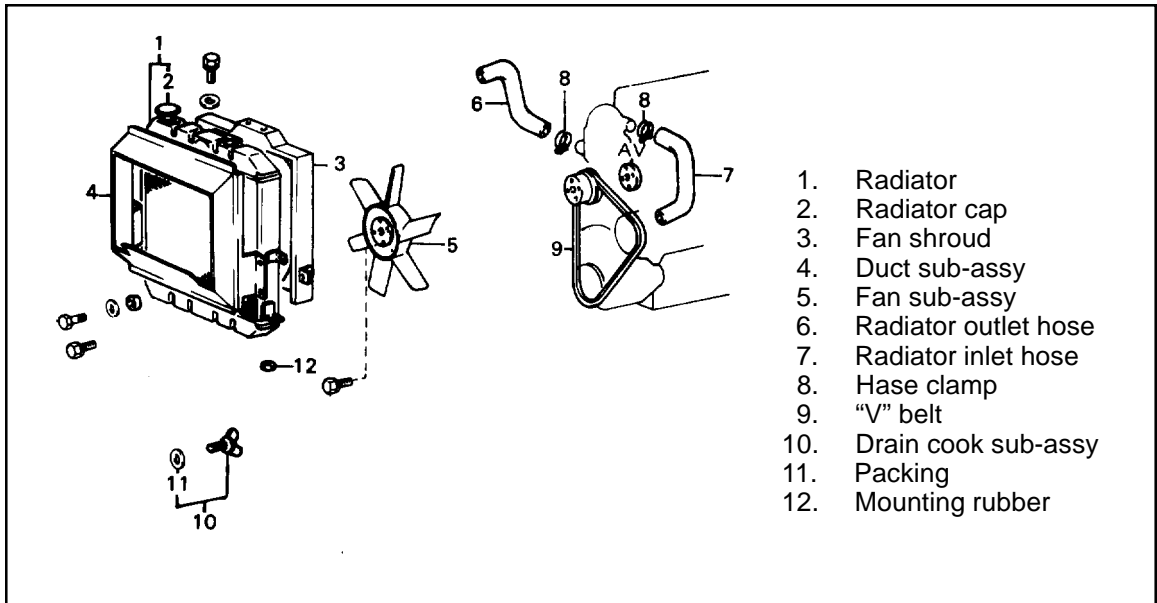

Fig. 1-37 Cleaning the air cleaner

RADIATOR



1. Radiator
2. Radiator cap
3. Fan shroud
4. Duct sub-assy
5. Fan sub-assy
6. Radiator outlet hose
7. Radiator inlet hose
8. Hase clamp
9. "V" belt
10. Drain cook sub-assy
11. Packing
12. Mounting rubber

Fig. 1-38 Radiator components

COOLANT AND ANTIFREEZE VOLUMES

	Radiator capacity	Total coolant volume	25% antifreeze mixing Above -12°C (10°F)	30% antifreeze mixing Above -15°C (5°F)	40% antifreeze mixing Above -24°C (-11°F)	Anti-corro-sive Agent 5%
Diesel model	9ℓ (2.37 US gal)	17.9ℓ (4.73US gal)	4.45ℓ (1.18 US gal)	5.37ℓ (1.42 US gal)	7.16ℓ (1.89 US gal)	0.9ℓ (0.24 US gal)
Gasoline model	9ℓ (2.37 US gal)	18.9ℓ (5.0 US gal)	4.73ℓ (1.25 US gal)	5.67ℓ (1.5 US gal)	7.56ℓ (2.0 US gal)	0.95ℓ (0.25 US gal)

RADIATOR REMOVAL AND INSTALLATION

1. Drain the coolant.
 - (1) Radiator draining
 - (2) Engine draining

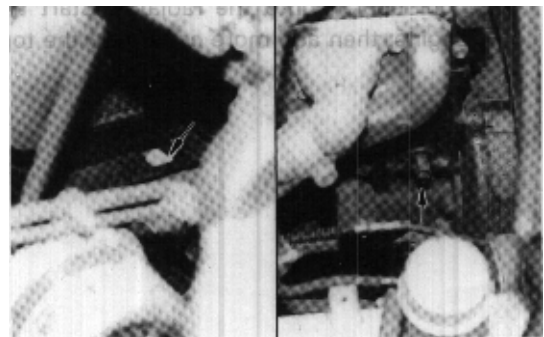

Fig. 1-39 Draining the coolant

Remove the balance weight.

- (1) Put the wire around the balance weight.
- (2) Set bolts (2pcs)
- (3) Balance weight

Reference: Weight of balance weight
FDC/FGC33 series Approx. 1,840kg (4,048 lb)
FDC/FGC35 series Approx. 2,190kg (4,818 lb)
FDC/FGC40 series Approx. 2,510kg (5,522 lb)
FDC/FGC45 series Approx. 2,890kg (6,358 lb)

Remove the muffler assembly.

- (1) Exhaust pipe connector
- (2) Muffler set bolts
- (3) Muffler assembly

Remove the radiator assembly.

- (1) Disconnect the inlet and outlet hoses.
- (2) Disconnect the torque converter cooler hoses. (2 pcs)
- (3) Set bolts
- (4) Radiator assembly

Cautions.

Remove the radiator carefully to avoid damage to the fins.

NOTE:

Pour coolant into the radiator. Start the engine, then add more coolant to the top.

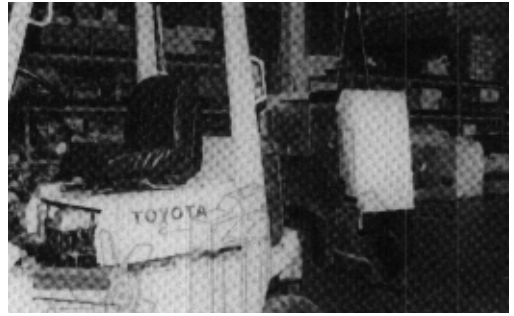

Fig. 1-40 Removing the balance weight

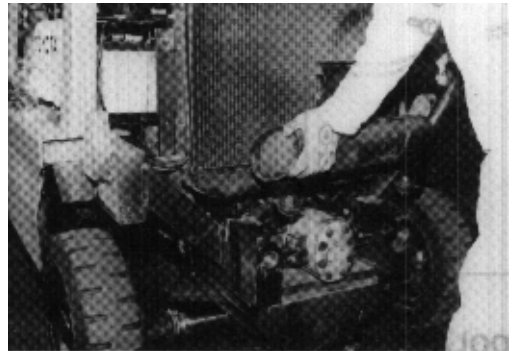

Fig. 1-41 Removint the muffler assembly



Fig. 1-42 Removing the radiator assembly



Suggest:

For more complete manuals. Please go to the home page.

<https://www.ebooklibonline.com>

If the above button click is invalid. Please download this document first, and then click the above link to download the complete manual.

Thank you so much for reading

MUFFLER

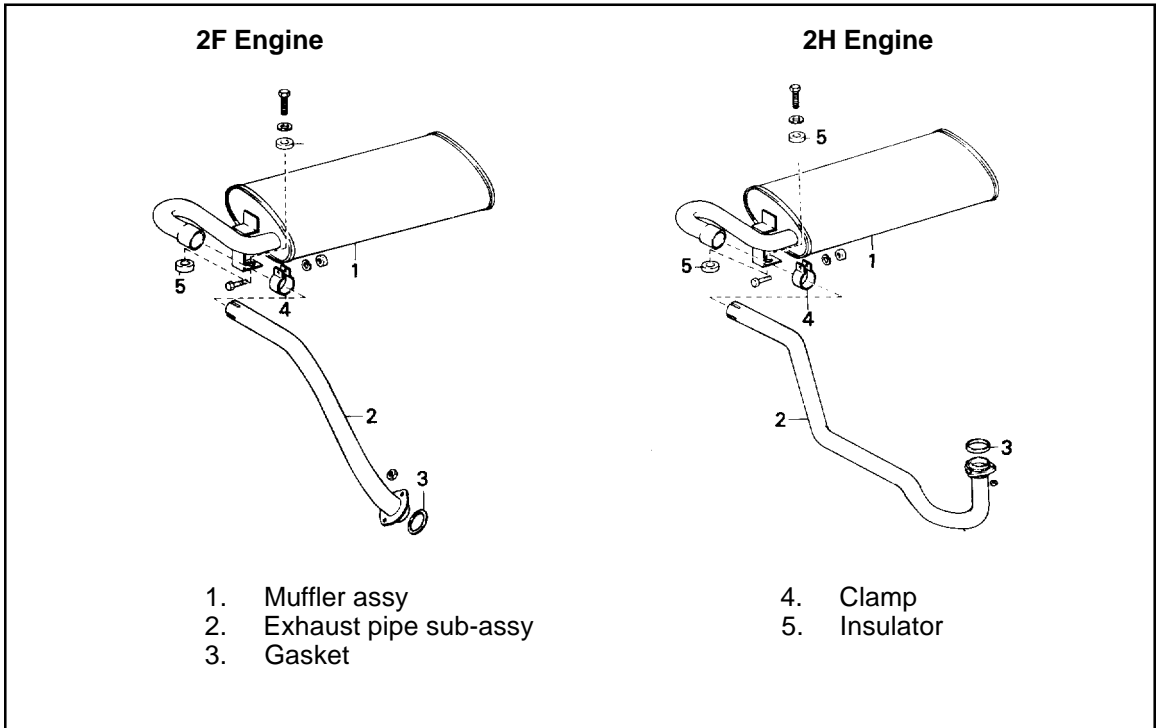

Fig. 1-43 Muffler components

MUFFLER REMOVAL AND INSTALLATION

Remove the balance weight.

- (1) Put the wire around the balance weight.
- (2) Set bolts (2pcs)
- (3) Balance weight

Reference: Weight of balance weight

FDC/FGC33 series Approx. 1,840kg (4,048 lb)

FDC/FGC35 series Approx. 2,190kg (4,818 lb)

FDC/FGC40 series Approx. 2,510kg (5,522 lb)

FDC/FGC45 series Approx. 2,890kg (6,358 lb)

Remove the muffler assembly.

- (1) Exhaust pipe connector
- (2) Muffler set bolts
- (3) Muffler assembly

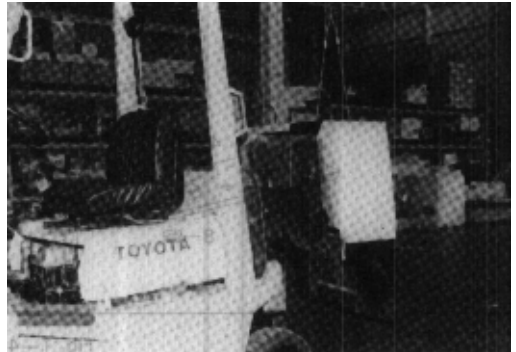
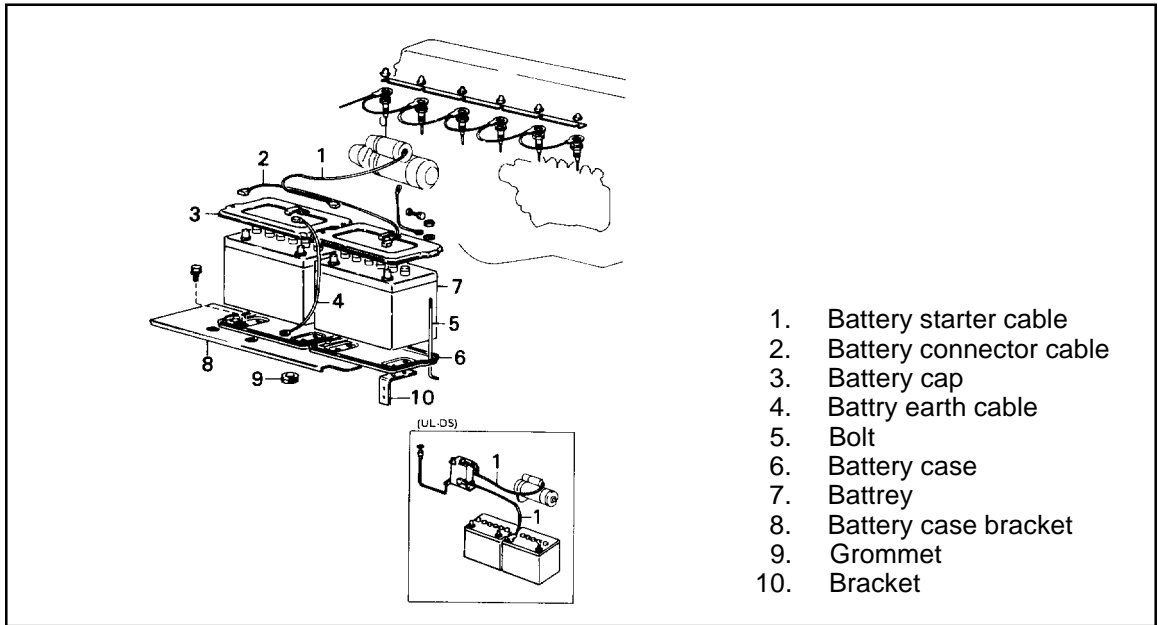

Fig. 1-44 Removing the balance weight



Fig. 1-45 Removing the muffler assembly

BATTERY



- 1. Battery starter cable
- 2. Battery connector cable
- 3. Battery cap
- 4. Battery earth cable
- 5. Bolt
- 6. Battery case
- 7. Battery
- 8. Battery case bracket
- 9. Grommet
- 10. Bracket

Fig. 1-46 Battery components (2H)

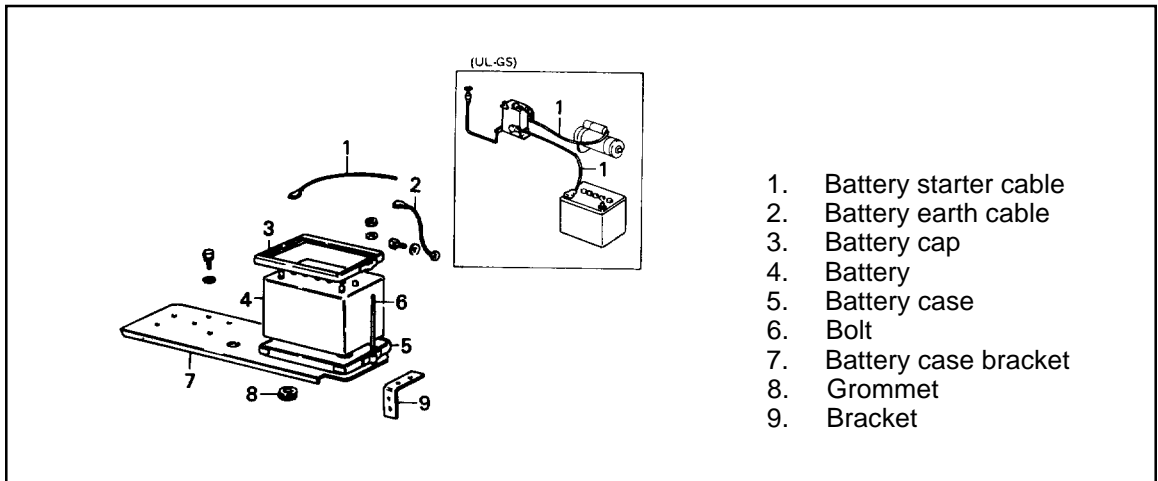

- 1. Battery starter cable
- 2. Battery earth cable
- 3. Battery cap
- 4. Battery
- 5. Battery case
- 6. Bolt
- 7. Battery case bracket
- 8. Grommet
- 9. Bracket

Fig. 1-47 Battery components (2F)

SPECIFICATION

	2H engine vehicle	2F engine vehicle
Battery type	N70Z (2 pcs.)	N50Z (1 pc.)
Voltage and capacity	12V, 70 AH x 2	12V, 60 AH

INSPECTION

- 1. Battery fluid level
- 2. Battery fluid specific gravity
1.260 (at 20°C at full charge)(68°F)
- 3. Battery terminal staining
- 4. Loosening of cable connections

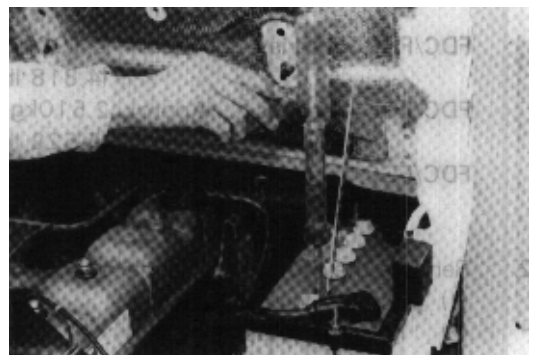

Fig. 1-48 Inspecting the battery

<https://www.ebooklibonline.com>

Hello dear friend!

Thank you very much for reading.

Enter the link into your browser.

The full manual is available for immediate download.

<https://www.ebooklibonline.com>