

FOREWORD

This Manual contains maintenance, specifications and repair procedures for the chassis, body and material handling system of the TOYOTA ELECTRIC POWERED TOWING TRACTOR CBT4,6 · CBTY4.

Please use these manuals for providing quick, correct servicing of the corresponding towing tractor.

This manual deals with the above models as of September 2003. Please understand that disagreement can take place between the descriptions in the manual and actual vehicles due to change in design and specifications. Any change or modifications thereafter will be informed by Toyota Industrial Equipment Parts & Service News.

TOYOTA Material Handling Company

A Division of TOYOTA INDUSTRIES CORPORATION

SECTION INDEX

NAME	SECTION
GENERAL	0
BATTERY	1
CONTROLLER	2
ELECTRICAL SYSTEM TROUBLESHOOTING	3
MOTOR	4
DRIVE UNIT	5
FRONT AXLE	6
REAR AXLE	7
STEERING	8
BRAKE	9
BODY•FRAME	10
APPENDIX	11

GENERAL

	Page		Page
VEHICLE EXTERIOR VIEW	0-2	PERIODIC MAINTENANCE	0-18
Vehicle models	0-3	PERIODIC REPLACEMENT OF PARTS AND LUBRICANTS	0-21
FRAME NUMBER	0-4	NEW MODEL FEATURES	0-22
HOW TO USE THIS MANUAL ..	0-5	DEVELOPMENT OBJECTIVES	0-22
EXPLANATION METHOD	0-5	SELLING POINTS	0-22
TERMINOLOGY	0-6	OUTLINE OF MAJOR FUNCTIONS	0-23
ABBREVIATIONS	0-6	PERFORMANCES	0-25
OPERATING TIPS	0-7	VEHICLE SPECIFICATIONS	0-26
GENERAL INSTRUCTIONS	0-7		
JACK-UP POINT	0-8		
HOISTING THE VEHICLE	0-9		
WIRE ROPE SUSPENSION			
ANGLE LIST	0-10		
SAFE LOAD FOR EACH WIRE			
ROPE SUSPENSION ANGLE	0-10		
MEMBER WEIGHTS	0-11		
TOWING THE VEHICLE	0-11		
ELECTRICAL PARTS			
INSPECTION	0-12		
STANDARD BOLT & NUT			
TIGHTENING TORQUES	0-13		
BOLT STRENGTH CLASS			
IDENTIFICATION METHOD	0-13		
TIGHTENING TORQUE TABLE	0-14		
PRECOATED BOLTS	0-15		
HIGH PRESSURE HOSE FITTING			
TIGHTENING TORQUE	0-15		
RECOMMENDED LUBRICANT			
QUANTITY AND TYPES	0-16		
LUBRICATION CHART	0-17		

<https://www.ebooklibonline.com>

Hello dear friend!

Thank you very much for reading.

Enter the link into your browser.

The full manual is available for immediate download.

<https://www.ebooklibonline.com>

VEHICLE EXTERIOR VIEW

CBT4-6

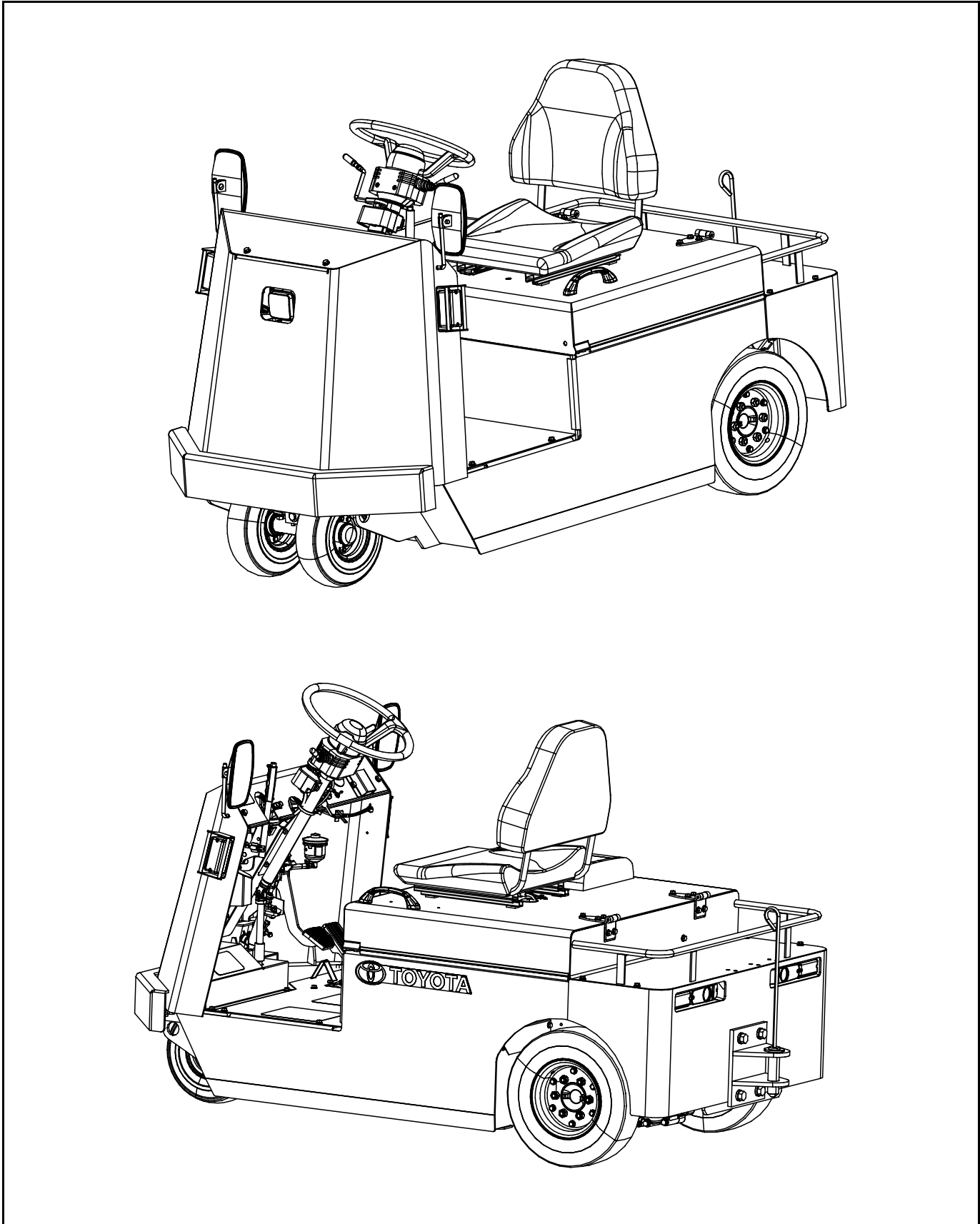

CBTY4

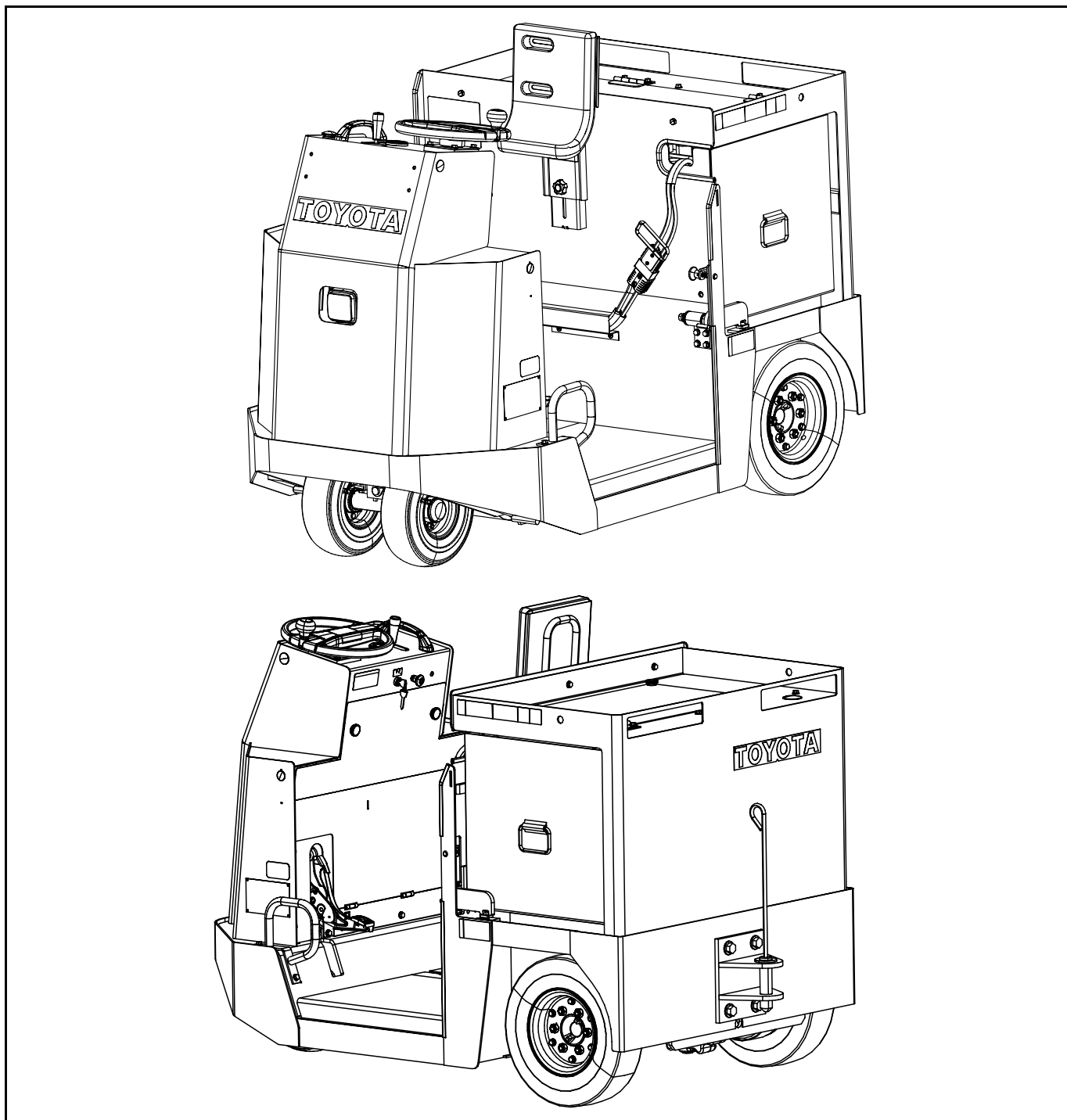

0

VEHICLE MODELS

Type	Model	Control method
4.0 t	CBT4	Transistor chopper
	CBTY4	↑
6.0 t	CBT6	↑

FRAME NUMBER

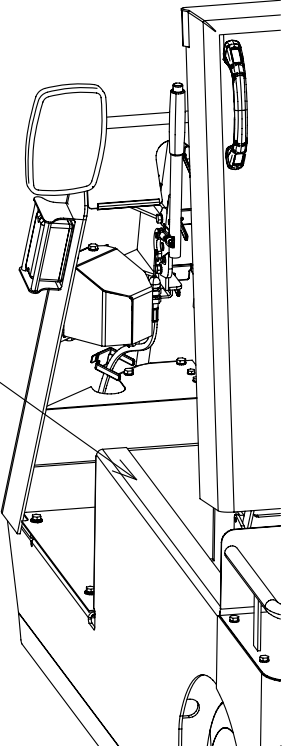
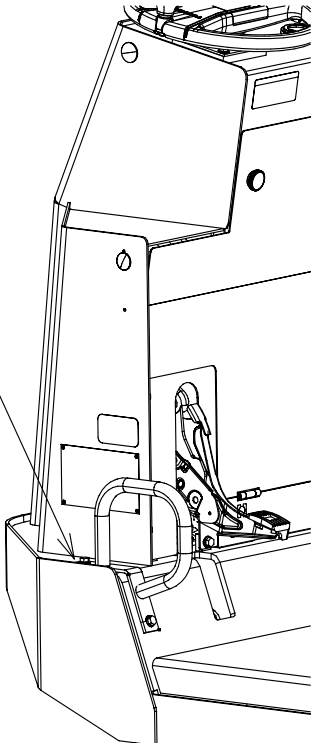
Vehicle model	CBT4	CBTY4	CBT6
Punching format	CBT4-10011	CBTY4-10011	CBT6-10011
Punching position	<p>CBT4•6</p>  <p>Left-hand frame side plate top</p>		
	<p>CBTY4</p>  <p>Left-hand front protector frame top</p>		

HOW TO USE THIS MANUAL

EXPLANATION METHOD

1. Operating procedure

(1) Operating procedures are described using either pattern A or pattern B.

Pattern A: Each step of the operation is explained with its own illustration.

Pattern B: The entire operation is indicated by step numbers in one illustration, followed by cautions, notes, and point operations.

Example of pattern B

DISASSEMBLY•INSPECTION•REASSEMBLY

Tightening torque unit $T=N\cdot m$ (kg·m) [ft·lbf]

- Some step numbers may be omitted in some illustrations.
- When a part requiring tightening torque instruction is not indicated in the illustration, the part name is described in the illustration frame.

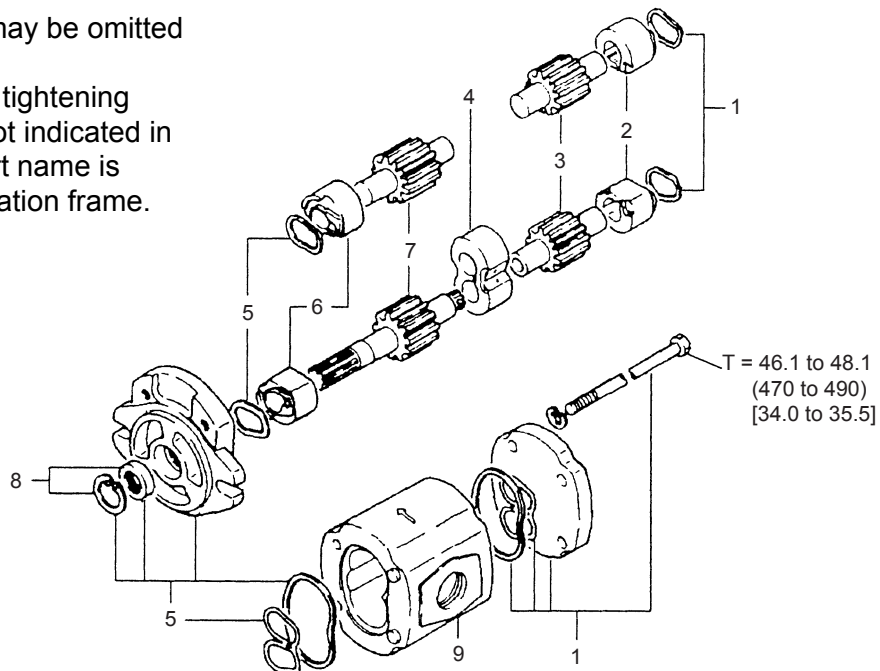

Disassembly Procedure

- 1 Remove the cover. **[Point 1]**
- 2 Remove the bushing. **[Point 2]**
- 3 Remove the gear.

← Operation to be explained

Point Operations

[Point 1]

Disassembly:

Make match marks before removing the pump cover.

↙ Explanation of operation point with illustration

[Point 2]

Inspection:

Measure the bushing inside diameter.

Limit 19.12 mm (0.7528 in)

2. How to read component figures

- (1) The component figures use the illustration in the parts catalog for the vehicle model. Please refer to the catalog to check the part name.

3. Matters omitted from this manual

- (1) This manual omits descriptions of the following jobs, but perform them in actual operation:
- (a) Cleaning and washing of removed parts as required
 - (b) Visual inspection (partially described)

(Example)

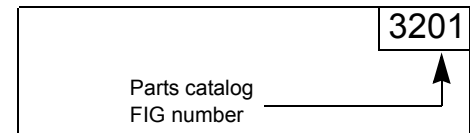

TERMINOLOGY

Caution:

Important matters, negligence of which may cause accidents. Be sure to observe them.

Note:

Important items, negligence of which may cause accidents, or matters in operating procedure which require special attention.

Standard: Value showing the allowable range in inspection or adjustment.

Limit: The maximum or minimum value allowed in inspection or adjustment.

ABBREVIATIONS

Abbreviation	Meaning	Abbreviation	Meaning
ASSY	Assembly	SAE	Society of Automotive Engineers (USA)
LH	Left hand	SST	Special service tool
L/	Less	STD	Standard
OPT	Option	T=	Tightening torque
O/S	Oversize	OOT	Number of teeth (OOT)
PS	Power steering	U/S	Undersize
RH	Right hand	W/	With

OPERATING TIPS

GENERAL INSTRUCTIONS

1. Safe operation

- (1) After jacking up, always support with wooden blocks or rigid stands.
- (2) When hoisting the vehicle or its heavy component, use wire rope(s) with a sufficient reserve in load capacity.
- (3) Always disconnect the battery plug before the inspection or servicing of electrical parts.

2. Skillful operation

- (1) Prepare the tools, necessary measuring instruments (circuit tester, megohmmeter, oil pressure gauge, etc.) and SSTs before starting operation.
- (2) Check the cable color and wiring state before disconnecting any wiring.
- (3) When overhauling functional parts, complicated sections or related mechanisms, arrange the parts neatly to prevent confusion.
- (4) When disassembling and inspecting a precision part such as a control valve, use clean tools and operate in a clean location.
- (5) Follow the specified procedures for disassembly, inspection and reassembly.
- (6) Always replace gaskets, packings, O-rings, self-locking nuts and cotter pins with new ones each time they are disassembled.
- (7) Use genuine Toyota parts for replacement.
- (8) Use specified bolts and nuts and observe the specified tightening torque when reassembling. (Tighten to the medium value of the specified tightening torque range.) If no tightening torque is specified, use the value given in the "standard tightening torque table".

3. Protection of functional parts (battery operated vehicles)

- (1) Before connecting the battery plug after vehicle inspection or maintenance, thoroughly check each connector for any faulty or imperfect connection.
Faulty or imperfect connection of connectors related to controllers, especially, may damage elements inside the controllers.

4. Defect status check

Do not start disassembly and/or replacement immediately, but first check that disassembly and/or replacement is necessary for the defect.

5. Waste fluid disposal

Always use a proper container when draining waste fluid from the vehicle.

Careless discharge of oil, fuel, coolant, oil filter, battery or other harmful substance may adversely affect human health and the environment. Always collect and sort well, and ask specialized companies for appropriate disposal.

JACK-UP POINT

Always observe the following instructions when jacking up the vehicle:

- Park the vehicle on a flat surface. Be sure to avoid an inclined or rough surface.
- Use a jack with ample capacity and jack up the vehicle at the specified jack-up point. Jacking up at any other point is dangerous.
- Always support the load of jacked-up vehicle with wooden blocks at specified points. Supporting the vehicle with the jack only is very dangerous.
- Never, under any circumstances, put any part of the body (including hands and feet) under the jacked-up vehicle.

CBT4-6

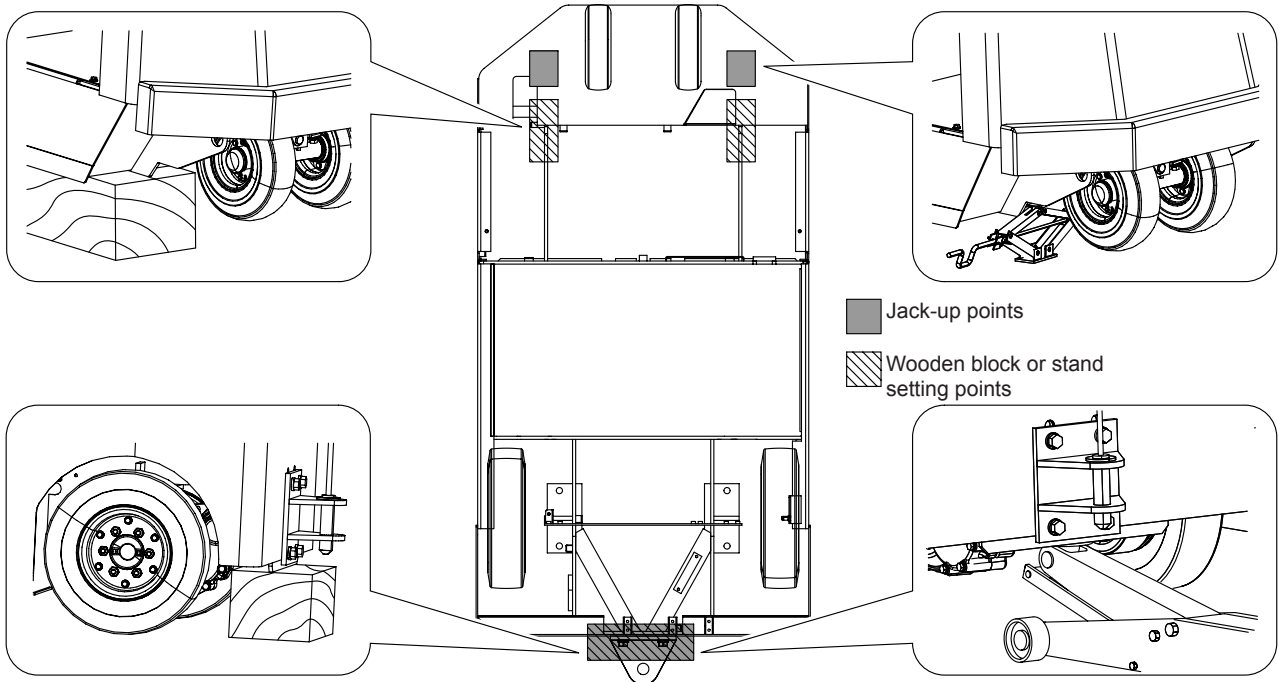

CBTY4

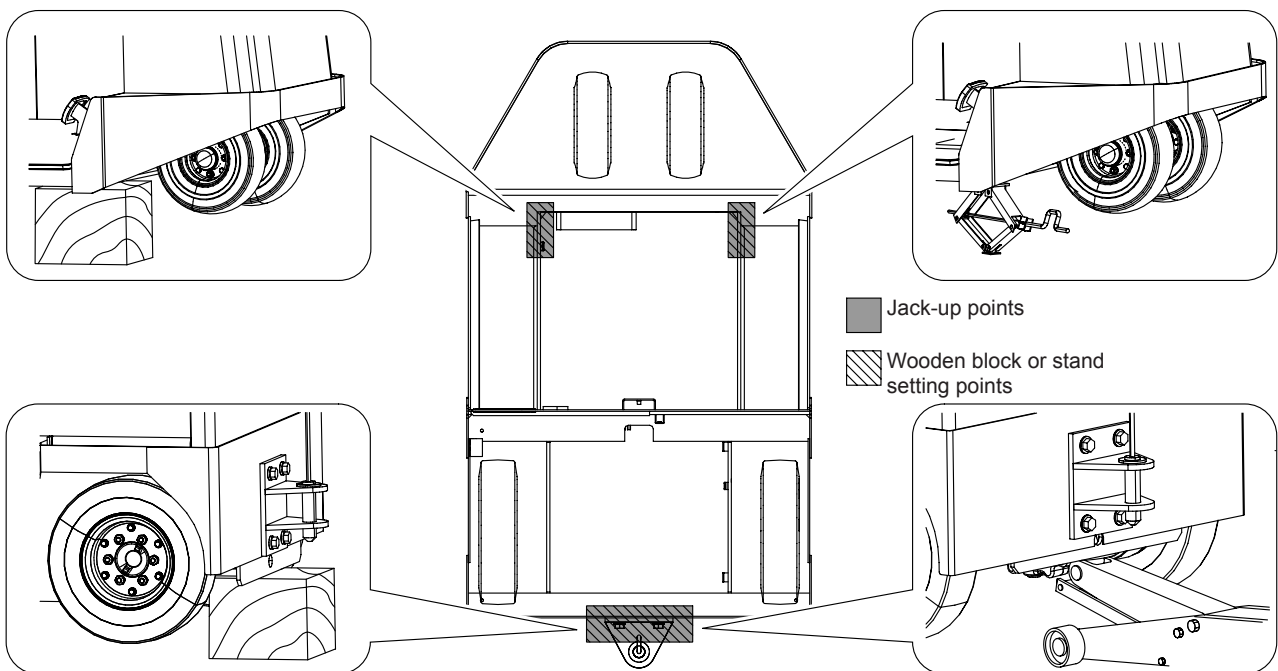

HOISTING THE VEHICLE

When hoisting the vehicle, always observe the specified hoist attachment section and method. Never hoist by any other attachment section as it is very dangerous.

CBT4-6

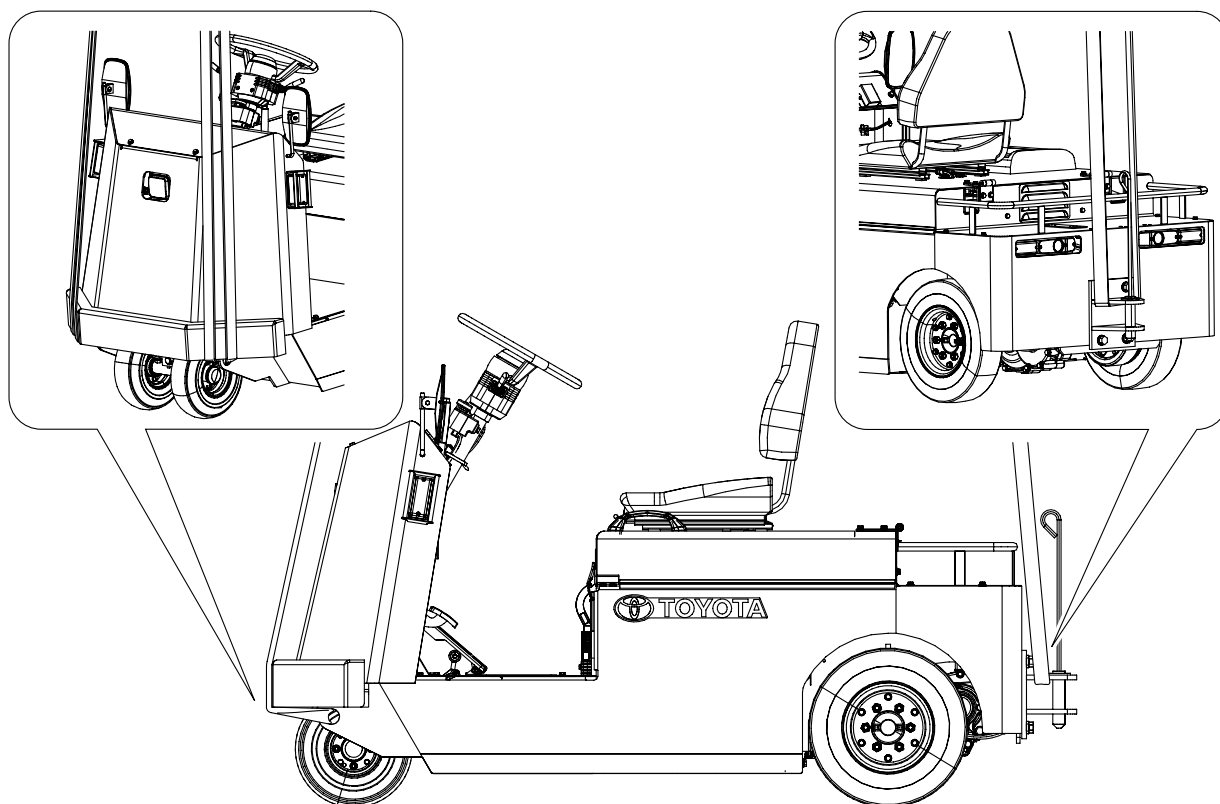

CBTY4

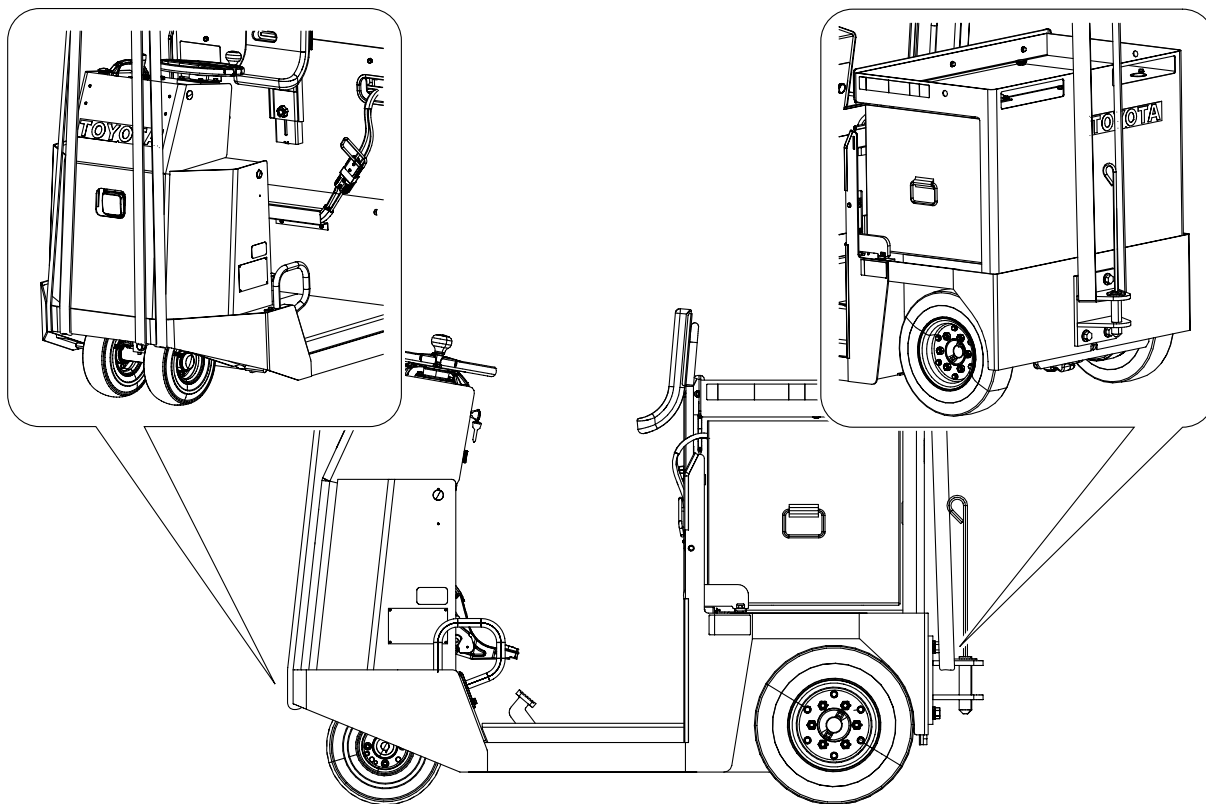

WIRE ROPE SUSPENSION ANGLE LIST

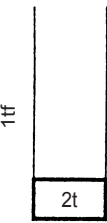
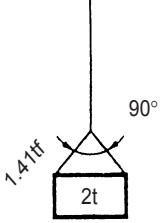
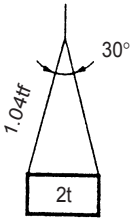
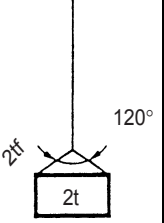
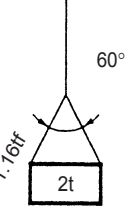
Suspension angle	Tension	Compression	Suspension method	Suspension angle	Tension	Compression	Suspension method
0°	1.00 time	0 time		90°	1.41 time	1.00 time	
30°	1.04 time	0.27 time		120°	2.00 time	1.73 time	
60°	1.16 time	0.58 time					

SAFE LOAD FOR EACH WIRE ROPE SUSPENSION ANGLE

Unit: N (tf) [lbf]

Rope diameter	Cutting load	Single-rope suspension	Two-rope suspension				Four-rope suspension			
		0°	0°	30°	60°	90°	0°	30°	60°	90°
6 mm (0.24 in)	21380 (2.18) [4807]	3040 (0.31) [683.6]	6080 (0.62) [1367]	5880 (0.60) [1323]	5200 (0.53) [1169]	4310 (0.44) [970]	12160 (1.24) [2734]	11770 (1.20) [2646]	10400 (1.06) [2337]	8630 (0.88) [1940]
8 mm (0.32 in)	31480 (3.21) [7078]	4410 (0.45) [992.3]	8830 (0.90) [1985]	8530 (0.87) [1918]	7650 (0.78) [1720]	6280 (0.64) [1411]	17650 (1.80) [3969]	17060 (1.74) [3937]	15300 (1.56) [3440]	12550 (1.28) [2822]
10 mm (0.4 in)	49230 (5.02) [11690]	6960 (0.71) [1565.6]	14020 (1.43) [3153]	13440 (1.37) [3021]	11770 (1.20) [2646]	9810 (1.00) [2205]	27460 (2.80) [6174]	26480 (2.70) [5954]	23540 (2.40) [5292]	19610 (2.00) [4410]
12.5 mm (0.5 in)	76880 (7.84) [17387]	10980 (1.12) [2469.5]	21570 (2.20) [4851]	21280 (2.10) [4631]	18630 (1.90) [4190]	14710 (1.50) [3308]	43150 (4.40) [9702]	41190 (4.20) [9261]	37270 (3.80) [8379]	29420 (3.00) [6615]
14 mm (0.56 in)	96400 (9.83) [21675]	13730 (1.40) [3087]	27460 (2.80) [6174]	26480 (2.70) [5954]	23540 (2.40) [5292]	18630 (1.90) [4190]	54920 (5.60) [12348]	52960 (5.40) [11907]	47070 (4.80) [10584]	37270 (3.80) [8379]

MEMBER WEIGHTS

unit: kg (lbs)

Member	Vehicle model	Weight
Battery ASSY	See page 1-2	
Drive motor ASSY	CBT4•CBTY4	Approx. 27 (60)
	CBT6	Approx. 45 (99)
Rear axle and drive unit ASSY W/drive motor	CBT4•CBTY4	Approx. 96 (112)
	CBT6	Approx. 117 (258)
Front axle ASSY (W/LH and RH front wheels)	All models	Approx. 15 (33)
Battery hood	CBTY4	Approx. 90 (200)
Vehicle weight	CBT4	980 (2160)
	CBTY4	975 (2150)
	CBT6	1055 (2325)

TOWING THE VEHICLE

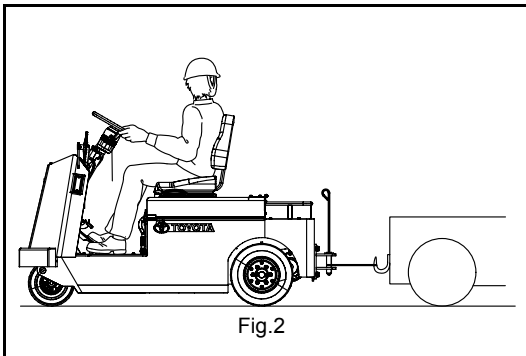
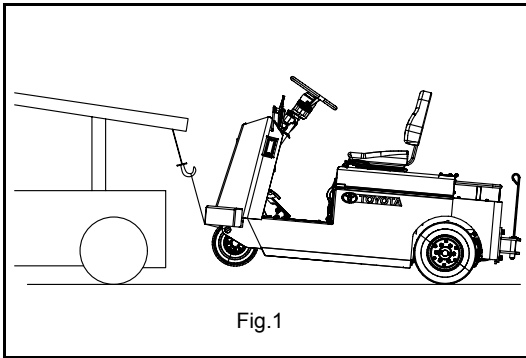

Note the cautions below when towing the vehicle.

- There are two towing methods:
 - Lift the front wheels (Fig. 1)
 - Not lift the front wheels (Fig. 2)
Steering operation is necessary.
- The traveling speed when towing must not exceed the maximum traveling speed of the vehicle.
- Before starting towing, always set the key switch to OFF and the direction switch to the neutral position.

CBTY4:EEC

- Disconnect the parking brake cable. (See PARKING BRAKE in Section 9 for the disconnection procedures.)
- There are two towing methods:
 - Lift the front wheels (Fig. 1)
 - Not lift the front wheels (Fig. 2)
Steering operation is necessary.
- The traveling speed when towing must not exceed the maximum traveling speed of the vehicle.
- Before starting towing, always set the key switch to OFF and the direction switch to the neutral position.

ELECTRICAL PARTS INSPECTION

1. Always disconnect the battery plug before inspecting or servicing electrical parts.
2. Pay sufficient attention when handling electronic parts.

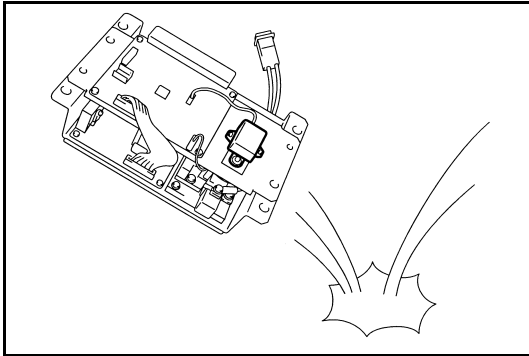

- (1) Never subject electronic parts, such as computers and relays, to impact.
- (2) Never expose electronic parts to high temperature or moisture.
- (3) Do not touch connector terminals, as they may be deformed or damaged due to static electricity.

3. Use a circuit tester that matches the object and purpose of measurement.

Analog type: This type is convenient for observing movement during operation and the operating condition. Measured value should be used for reference only.

Digital type: A fairly accurate reading is possible. However, it is difficult to observe operation or movement.

- (1) Difference between results of measurement with analog and digital types
 - * The results of measurements using the analog type and the digital type may be different. Differences between the polarities of the analog type and the digital type are described below.

1) Analog circuit tester

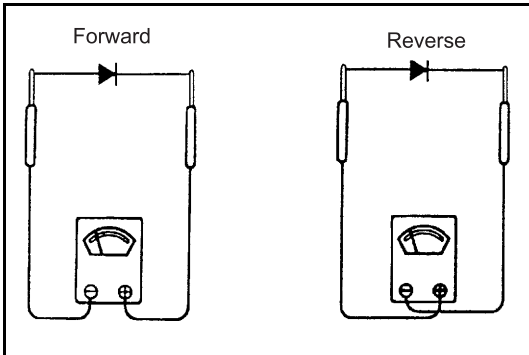

Example of measurement result
Tester range: kΩ range

	Analog type
Forward	Continuity
	11 kΩ
Reverse	No continuity
	∞

2) Digital circuit tester

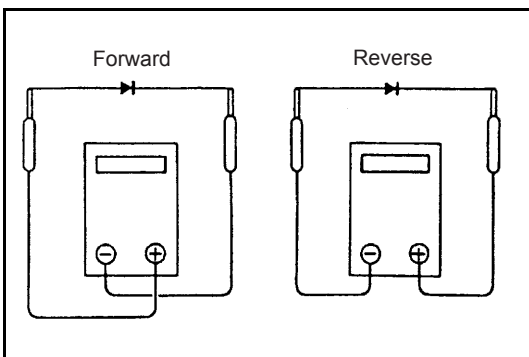

Example of measurement result
Tester range: 2 MΩ range

	Digital type
Forward	No continuity
	1
Reverse	Continuity
	2 MΩ









STANDARD BOLT & NUT TIGHTENING TORQUES

Tightening torques for standard bolts and nuts are not indicated throughout the manual. Use the charts and table below to judge the standard tightening torque.

1. Find the class of the bolt strength in the table below and then find the bolt tightening torque in the tightening torque table.
2. The nut tightening torque can be judged from its corresponding bolt type.

BOLT STRENGTH CLASS IDENTIFICATION METHOD

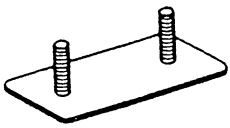
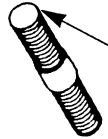
Identification by bolt shape

	Shape and class	Class
Hexagon head bolt	 Bolt with raised or etched numeral on head	4 = 4T
Hexagon bolt		5 = 5T
(standard)	 No mark	6 = 6T
		7 = 7T
		8 = 8T
Hexagon flange bolt	 No mark	4T
Hexagon head bolt (standard)	 Bolt with two raised lines on head	5T
Hexagon flange bolt	 Bolt with two raised lines on head	6T
Hexagon head bolt (standard)	 Bolt with three raised lines on head	7T
Hexagon head bolt (standard)	 Bolt with four raised lines on head	8T
Welded bolt		4T
Stud bolt	 No mark	4T
	 2 mm groove(s) on one/both edge(s)	6T

Identification by part No.

Hexagon head bolt

Part No. 91611-40625

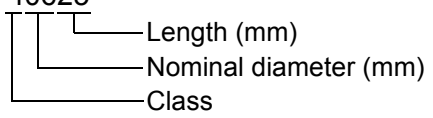

Length (mm)
Nominal diameter (mm)
Class

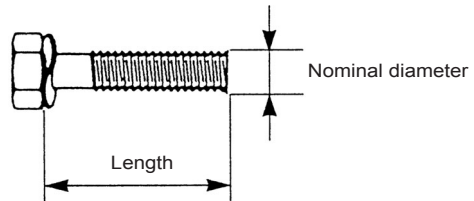

Stud bolt

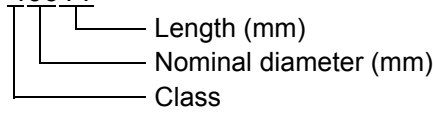

Part No. 92132-40614

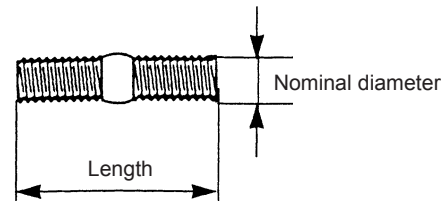

Length (mm)
Nominal diameter (mm)
Class

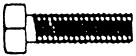

TIGHTENING TORQUE TABLE

Class	Nominal diameter mm	Pitch mm	Standard tightening torque					
			Hexagon head bolt 			Hexagon flange bolt 		
			N•m	kgf•cm	ft•lbf	N•m	kgf•cm	ft•lbf
4T	6	1.0	5.4	55	48 in•lbf	5.9	60	52 in•lbf
	8	1.25	13	130	9	14	145	10
	10	1.25	25	260	19	28	290	21
	12	1.25	47	480	35	53	540	39
	14	1.5	75	760	55	83	850	61
	16	1.5	113	1150	83	—	—	—
5T	6	1.0	6.4	65	56 in•lbf	7.5	75	65 in•lbf
	8	1.25	16	160	12	18	175	13
	10	1.25	32	330	24	36	360	26
	12	1.25	59	600	43	65	670	48
	14	1.5	91	930	67	100	1050	76
	16	1.5	137	1400	101	157	1600	116
6T	6	1.0	7.8	80	69 in•lbf	8.8	90	78 in•lbf
	8	1.25	19	195	14	21	215	16
	10	1.25	38	400	29	43	440	32
	12	1.25	72	730	53	79	810	59
	14	1.5	110	1100	80	123	1250	90
	16	1.5	170	1750	127	191	1950	141
7T	6	1.0	11	110	8	12	120	9
	8	1.25	25	260	19	28	290	21
	10	1.25	52	530	38	58	590	43
	12	1.25	95	970	70	103	1050	76
	14	1.5	147	1500	108	167	1700	123
	16	1.5	226	2300	166	—	—	—
8T	6	1.0	12	125	9	14	145	9
	8	1.25	29	300	22	32	330	24
	10	1.25	61	620	45	68	690	50
	12	1.25	108	1100	80	123	1250	90
	14	1.5	172	1750	127	196	2000	145
	16	1.5	265	2700	195	299	3050	221

PRECOATED BOLTS

(Bolts with seal lock agent coating on threads)

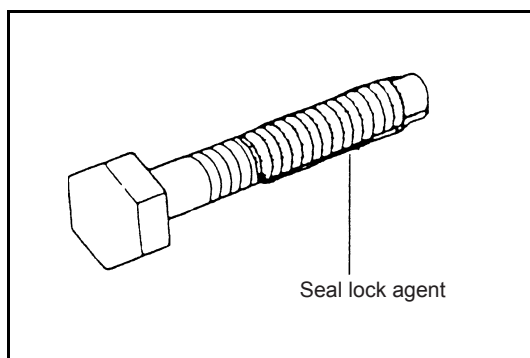

1. Do not use a pre-coated bolt as it is in either of the following cases:
 - (1) After it has been removed.
 - (2) When it has been moved by tightness check, etc. (loosened or tightened)

Note:

For torque check, tighten the bolt to the lower limit of the allowable tightening torque range; if the bolt moves, retighten it according to the steps below.

2. How to reuse pre-coated bolts
 - (1) Wash the bolt and threaded hole.
(The threaded hole must be washed even when replacing the bolt with a new one)
 - (2) Completely dry the washed parts by blowing with air.
 - (3) Apply a specified seal lock agent to the threaded portion of the bolt.

HIGH PRESSURE HOSE FITTING TIGHTENING TORQUE

1. When connecting a high pressure hose, wipe the hose fitting and corresponding nipple contact surfaces with a clean cloth to remove foreign matter and dirt. Also check that there are no dents or other damage on the contact surfaces before installation.
2. When connecting the high pressure hose, hold the hose to align the fitting with the nipple and tighten the fitting.
3. The maximum tightening torque must not exceed twice the standard tightening torque.

Nominal diameter of screw	Tightening torque standard N·m (kgf·cm) [ft·lbf]		Inside diameter of hose mm (in)
	Standard	Tightening range	
7/16-20UNF	25 (50) [18.1]	24 to 26 (240 to 270) [17.4 to 19.5]	6 (0.24)
9/16-18UNF	49 (500) [36.2]	47 to 52 (480 to 530) [34.7 to 38.3]	9 (0.35)
3/4-16UNF	59 (600) [43.4]	56 to 62 (570 to 630) [41.2 to 45.6]	12(0.47)
7/8-14UNF	59 (600) [43.4]	56 to 62 (570 to 630) [41.2 to 45.6]	12 (0.47)
7/8-14UNF	78 (800) [57.9]	74 to 82 (740 to 840) [53.5 to 60.8]	15 (0.59)
1•1/16-12UNF	118 (1200) [86.8]	112 to 123 (1140 to 1250) [82.5 to 90.4]	19 (0.75)
1•5/16-12UNF	137 (1400) [101.3]	130 to 144 (1330 to 1470) [96.2 to 106.4]	25 (0.98)
PF1/4	25 (250) [18.1]	24 to 26 (240 to 270) [17.4 to 19.5]	6 (0.24)
PF3/8	49 (500) [36.2]	47 to 52 (480 to 530) [34.7 to 38.3]	9 (0.35)
PF1/2	59 (600) [43.4]	56 to 62 (570 to 630) [41.2 to 45.6]	12 (0.47)
PF3/4	118 (1200) [86.8]	112 to 123 (1140 to 1250) [82.5 to 90.4]	19 (0.75)
PF1	137 (1400) [101.3]	130 to 144 (1330 to 1470) [96.2 to 106.4]	25 (0.98)



Suggest:

For more complete manuals. Please go to the home page.

<https://www.ebooklibonline.com>

If the above button click is invalid. Please download this document first, and then click the above link to download the complete manual.

Thank you so much for reading

RECOMMENDED LUBRICANT QUANTITY AND TYPES

Applicable portion	Type	Quantity
Drive unit	Hypoid gear oil SAE 75W-80	1.25 Liter (0.33 US gal) The oil level shall be within a range of 9 to 11 mm (0.354 to 0.433 in) from the bottom of the filler port. The above value is for reference
Brake line	SAE J-1703, DOT-3	Appropriate amount
Steering chains	Molybdenum disulfide grease	Appropriate amount
Chassis parts	MP Grease	Appropriate amount
Battery	Distilled water	Appropriate amount

LUBRICATION CHART

CBT4•6

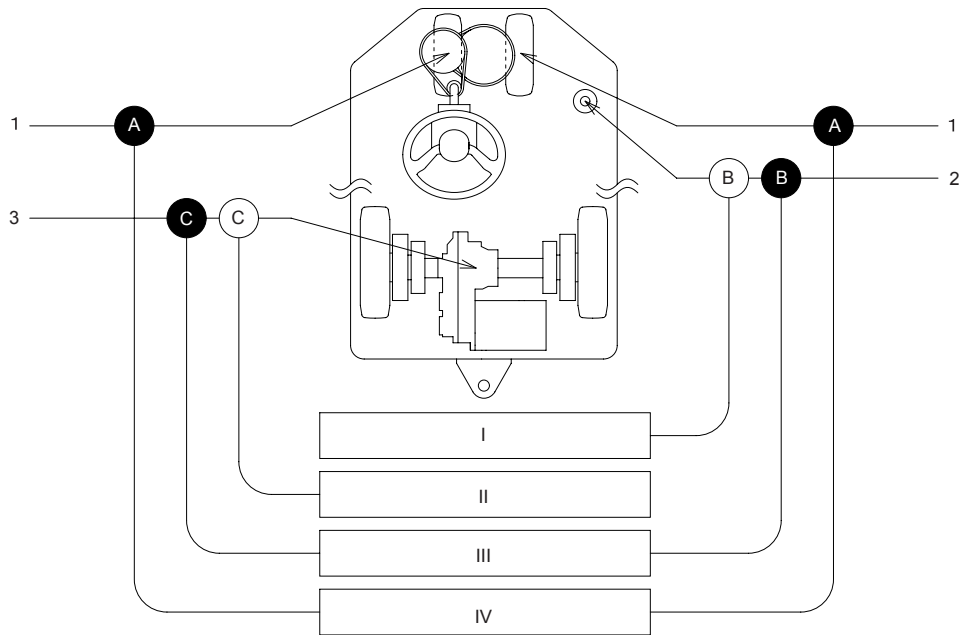

CBTY4

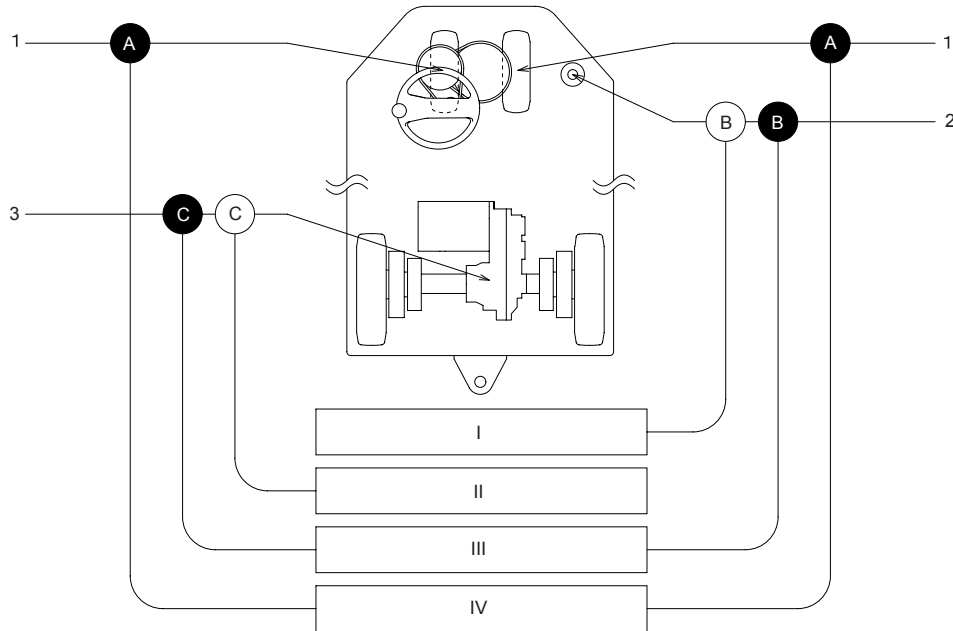

○: Inspection and addition

●: Replacement

A: MP grease

B: Brake fluid (SAE J-1703, DOT-3)

C: Gear oil (SAE 75W-80)

I. Inspection every 8 hours (daily)

II. Inspection every 250 hours (6 weekly)

III. Inspection every 1000 hours (6 monthly)

IV. Inspection every 2000 hours (annual)

1. Front wheel bearing

2. Brake fluid reservoir tank

3. Differential and drive unit

Note:

In case of a hand operating condition, the service interval of 170 hours or 1 month is recommendable.

<https://www.ebooklibonline.com>

Hello dear friend!

Thank you very much for reading.

Enter the link into your browser.

The full manual is available for immediate download.

<https://www.ebooklibonline.com>