



# D REPAIR

# M MANUAL

8FBET15, 16, 18, 20  
8FBEKT16, 18  
8FBMT15, 16, 18, 20

Pub. No. CE345-1

# FOREWORD

This manual covers the service procedures of the TOYOTA FORKLIFT 8FBET15~20/8FBEKT16,18/8FBMT15~20 series. Please use this manual for providing quick, correct servicing of the corresponding forklift models.

This manual deals with the above models as of November 2010. Please understand that disagreement can take place between the descriptions in the manual and actual vehicles due to change in design and specifications. Any change or modifications thereafter will be informed by Toyota Industrial Equipment Parts & Service News.

(Reference)

Repair manuals related to this manual are as follows:

TOYOTA INDUSTRIAL EQUIPMENT 8FBET15~20/8FBEKT16,18/  
8FBMT15~20 REPAIR MANUAL (No. CE345)

TOYOTA INDUSTRIAL EQUIPMENT 8FBET15~20/8FBEKT16,18/  
8FBMT15~20 NEW MODEL FEATURES (No. PE318)

**TOYOTA Material Handling Company**

A Division of TOYOTA INDUSTRIES CORPORATION

# SECTION INDEX

NAME	SECTION
<b>GENERAL</b>	<b>0</b>
<b>BATTERY</b>	<b>1</b>
<b>CONTROL SYSTEM</b>	<b>2</b>
<b>MULTI-FUNCTION DISPLAY</b>	<b>3</b>
<b>TROUBLESHOOTING</b>	<b>4</b>
<b>MOTOR</b>	<b>5</b>
<b>DRIVE UNIT &amp; FRONT AXLE</b>	<b>6</b>
<b>REAR AXLE</b>	<b>7</b>
<b>STEERING</b>	<b>8</b>
<b>BRAKE</b>	<b>9</b>
<b>BODY</b>	<b>10</b>
<b>MATERIAL HANDLING SYSTEM</b>	<b>11</b>
<b>MAST</b>	<b>12</b>
<b>CYLINDER</b>	<b>13</b>
<b>OIL PUMP</b>	<b>14</b>
<b>OIL CONTROL VALVE</b>	<b>15</b>
<b>SAS FUNCTIONS</b>	<b>16</b>
<b>MAIN OPTIONS</b>	<b>17</b>
<b>APPENDIX</b>	<b>18</b>

**<https://www.ebooklibonline.com>**

Hello dear friend!

Thank you very much for reading.

Enter the link into your browser.

The full manual is available for immediate download.

**<https://www.ebooklibonline.com>**

## GENERAL

	Page		Page
VEHICLE EXTERIOR VIEW ....	0-2	PERIODIC MAINTENANCE ..	0-22
VEHICLE MODELS .....	0-4	PERIODIC REPLACEMENT	
FRAME NUMBER.....	0-4	OF PARTS AND	
HOW TO USE THIS		LUBRICANTS.....	0-26
MANUAL.....	0-5		
EXPLANATION METHOD.....	0-5		
TERMINOLOGY .....	0-6		
ABBREVIATIONS.....	0-6		
SI UNITS .....	0-7		
OPERATING TIPS .....	0-8		
JACK-UP POINT .....	0-9		
HOISTING THE VEHICLE.....	0-10		
WIRE ROPE SUSPENSION			
ANGLE LIST .....	0-11		
SAFE LOAD FOR EACH			
WIRE ROPE SUSPENSION			
ANGLE.....	0-11		
COMPONENT WEIGHT.....	0-12		
TOWING THE VEHICLE.....	0-13		
ELECTRICAL PARTS			
INSPECTION .....	0-14		
STANDARD BOLT & NUT			
TIGHTENING TORQUE .....	0-15		
BOLT STRENGTH CLASS			
IDENTIFICATION METHOD ....	0-15		
PRECOAT BOLTS .....	0-18		
HIGH PRESSURE HOSE			
FITTING TIGHTENING			
TORQUE .....	0-18		
RECOMMENDED LUBRICANT			
QUANTITY AND TYPES .....	0-19		
LUBRICATION CHART .....	0-20		

## VEHICLE EXTERIOR VIEW

**8FBET15 - 20**

**8FBEKT16,18**

\* This illustration is  
Battery Roll-out  
(OPT) model.

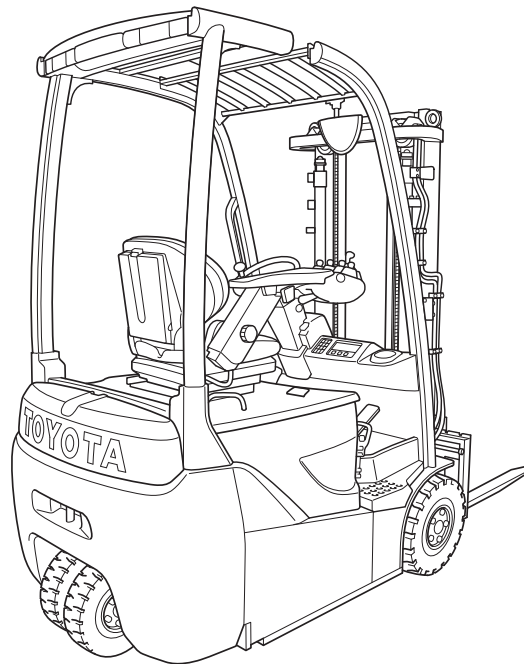
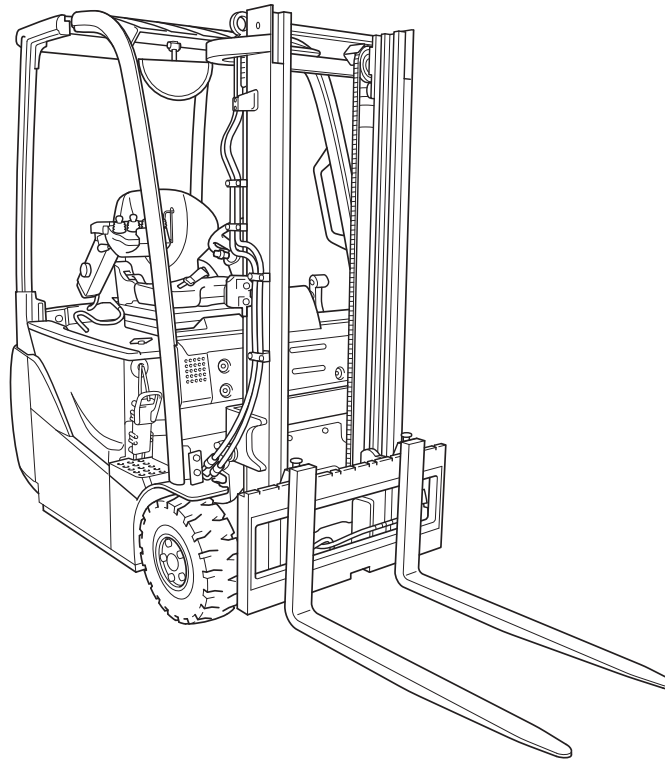

8FBMT15 - 20

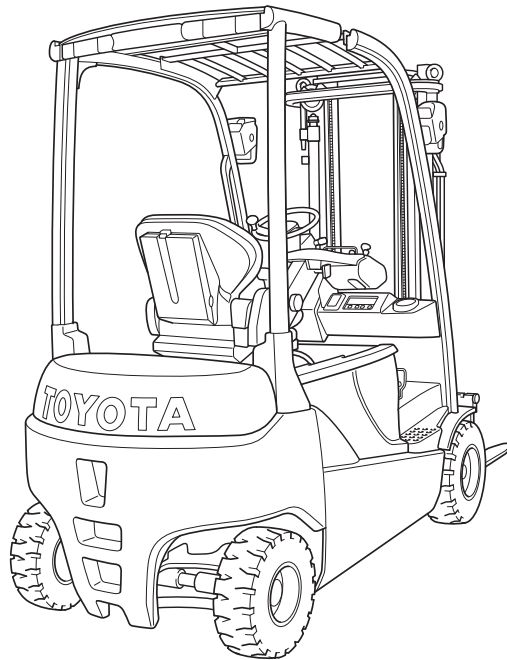
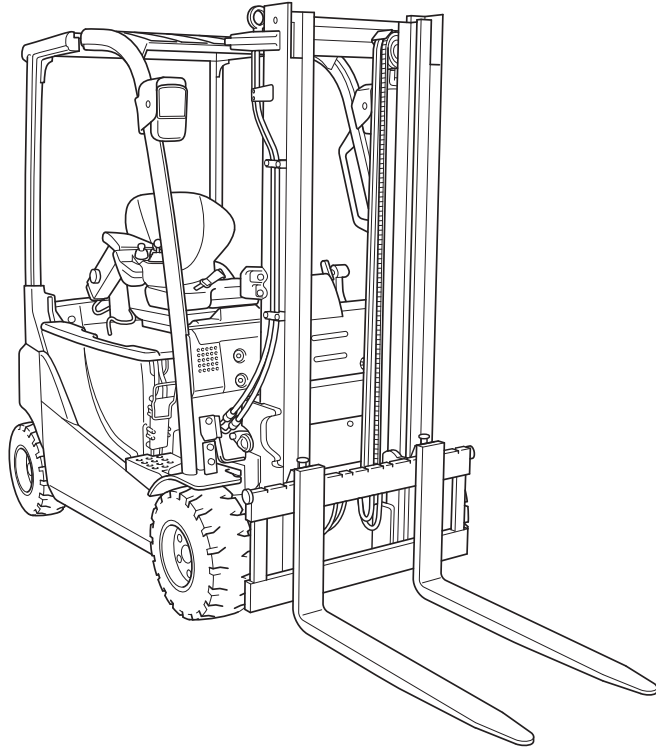

## VEHICLE MODELS

### 3-Wheel Models

Vehicle Model	Load Capacity	Control Method	Voltage (V)
8FBET15	1.5 ton	AC Microcomputer controller	48
8FBET16 8FBEKT16	1.6 ton	↑	↑
8FBET18 8FBEKT18	1.8 ton	↑	↑
8FBET20	2.0 ton	↑	↑

### 4-Wheel Models

Vehicle Model	Load Capacity	Control Method	Voltage (V)
8FBMT15	1.5 ton	AC Microcomputer controller	48
8FBMT16	1.6 ton	↑	↑
8FBMT18	1.8 ton	↑	↑
8FBMT20	2.0 ton	↑	↑

## FRAME NUMBER

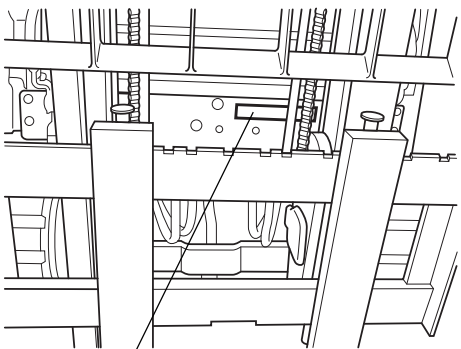
Vehicle model	Punching format	Punching position
8FBET15	8FBET15 ⑩ 10011	 <p>Punching Position</p>
8FBEKT16	8FBEKT16 ⑩ 10011	
8FBEKT18	8FBEKT18 ⑩ 10011	
8FBET16	8FBET16 ⑩ 10011	
8FBET18	8FBET18 ⑩ 10011	
8FBET20	8FBET20 ⑩ 10011	
8FBMT15	8FBMT15 ⑩ 10011	
8FBMT16	8FBMT16 ⑩ 10011	
8FBMT18	8FBMT18 ⑩ 10011	
8FBMT20	8FBMT20 ⑩ 10011	

## HOW TO USE THIS MANUAL

### EXPLANATION METHOD

#### 1. Operation procedure

- (1) The operation procedure is described in either pattern A or pattern B below.

Pattern A: Explanation of each operation step with illustration.

Pattern B: Explanation of operation procedure by indicating step numbers in one illustration, followed by explanation of cautions and notes summarized as point operations.

Example of description in pattern B

### DISASSEMBLY-INSPECTION-REASSEMBLY

Tightening torque unit T = N·m (kgf·cm) [ft·lbf]

- Step Nos. are partially sometimes omitted in illustrations.
- When a part requiring tightening torque instruction is not indicated in the illustration, the part name is described in the illustration frame.

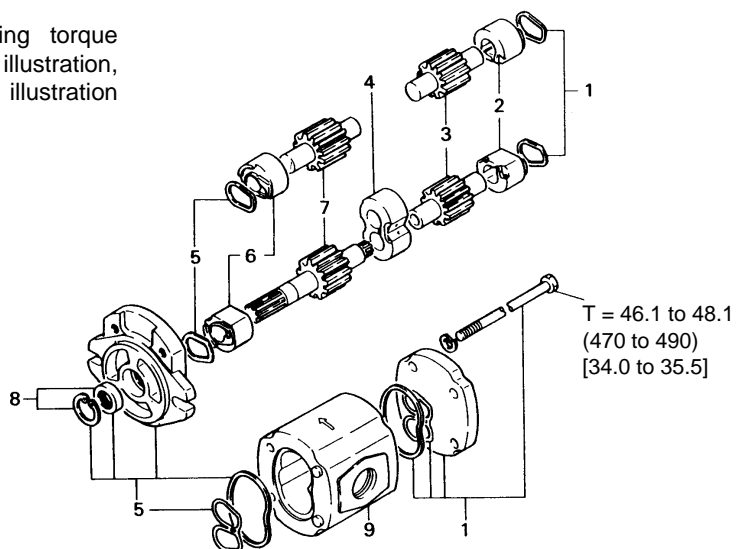

#### Disassembly Procedure

- 1 Remove the cover. **[Point 1]**
- 2 Remove the bushing. **[Point 2]** ← Operation explained later
- 3 Remove the gear.

#### Point Operations

**[Point 1]** Explanation of key point for operation with an illustration

Disassembly: ↙

Put a match mark when removing the pump cover.

#### **[Point 2]**

Inspection:

Measure the bush inside diameter.

**Limit: 19.12 mm (0.7528 in)**

2. How to read component figures

- (1) The component figures use the illustration in the parts catalog for the vehicle model. Please refer to the catalog to check the part name.

(Example)

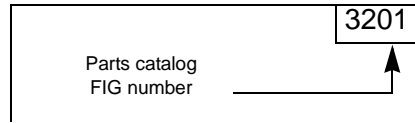

3. Matters omitted from this manual

- (1) This manual omits descriptions of the following jobs, but perform them in actual operation:
  - (a) Cleaning and washing of removed parts as required
  - (b) Visual inspection (partially described)

## TERMINOLOGY

**Caution:**

Important matters, negligence of which may cause accidents. Be sure to observe them.

**Note:**

Important items, negligence of which may cause accidents, or matters in operating procedure which require special attention.

**Standard:** Value showing the allowable range in inspection or adjustment

**Limit:** The maximum or minimum value allowed in inspection or adjustment.

## ABBREVIATIONS

Abbreviation	Meaning	Abbreviation	Meaning
ASSY	Assembly	SAE	Society of Automotive Engineers (USA)
ATT	Attachment	SAS	System of active stability
LH	Left hand	SST	Special service tool
L/	Less	STD	Standard
OPT	Option	T=	Tightening torque
O/S	Oversize	OOT	Number of teeth (OOT)
PS	Power steering	U/S	Undersize
RH	Right hand	W/	With

**GENERAL**

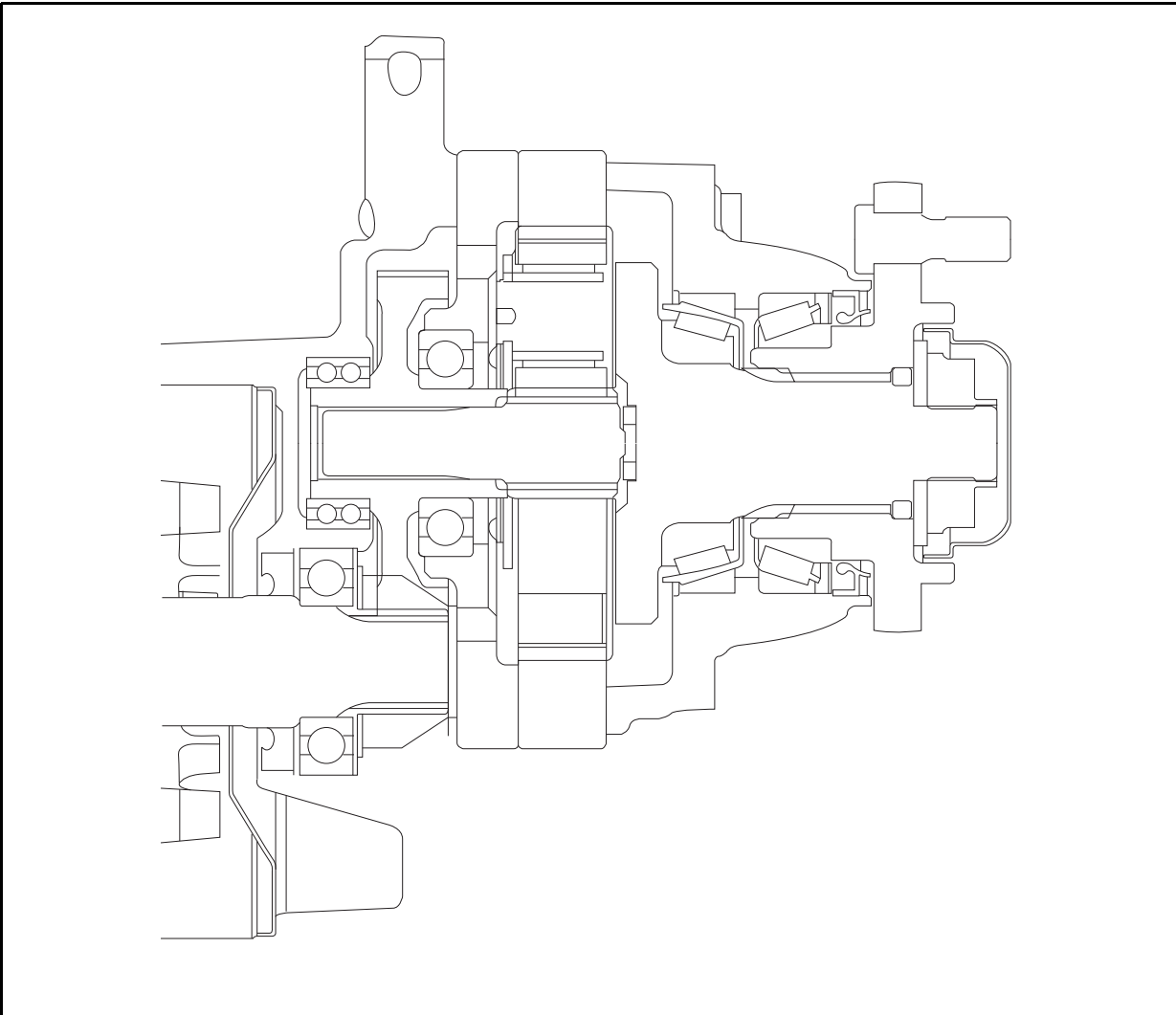

## SPECIFICATIONS

3W:

Vehicle models Item	8FBET15				8FBEKT16			
	STD	S/D	CABIN	S/D+CABIN	STD	S/D	CABIN	S/D+CABIN
Front tire size	18x7-8	←	←	←	18x7-8	←	←	←
Rim size	4.33R-8	←	←	←	4.33R-8	←	←	←
Rim type	SIT	←	←	←	SIT	←	←	←

Vehicle models Item	8FBET16				8FBEKT18			
	STD	S/D	CABIN	S/D+CABIN	STD	S/D	CABIN	S/D+CABIN
Front tire size	18x7-8	←	←	←	18x7-8	205/50-10	←	←
Rim size	4.33R-8	←	←	←	4.33R-8	6.50F-10	←	←
Rim type	SIT	←	←	←	SIT	←	←	←

Vehicle models Item	8FBET18				8FBET20			
	STD	S/D	CABIN	S/D+CABIN	STD	S/D	CABIN	S/D+CABIN
Front tire size	205/50-10	←	←	←	205/50-10	←	←	←
Rim size	6.50F-10	←	←	←	6.50F-10	←	←	←
Rim type	SIT	←	←	←	SIT	←	←	←

4W:

Vehicle models Item	8FBMT15				8FBMT16			
	STD	S/D	CABIN	S/D+CABIN	STD	S/D	CABIN	S/D+CABIN
Front tire size	18x7-8	←	←	←	18x7-8	←	←	←
Rim size	4.33R-8	←	←	←	4.33R-8	←	←	←
Rim type	SIT	←	←	←	SIT	←	←	←

Vehicle models Item	8FBMT18				8FBMT20			
	STD	S/D	CABIN	S/D+CABIN	STD	S/D	CABIN	S/D+CABIN
Front tire size	205/50-10	←	←	←	205/50-10	←	←	←
Rim size	6.50F-10	←	←	←	6.50F-10	←	←	←
Rim type	SIT	←	←	←	SIT	←	←	←



## DRIVE UNIT ASSY

### REMOVAL-INSTALLATION

T=N·m (kgf·cm) [ft·lbf]

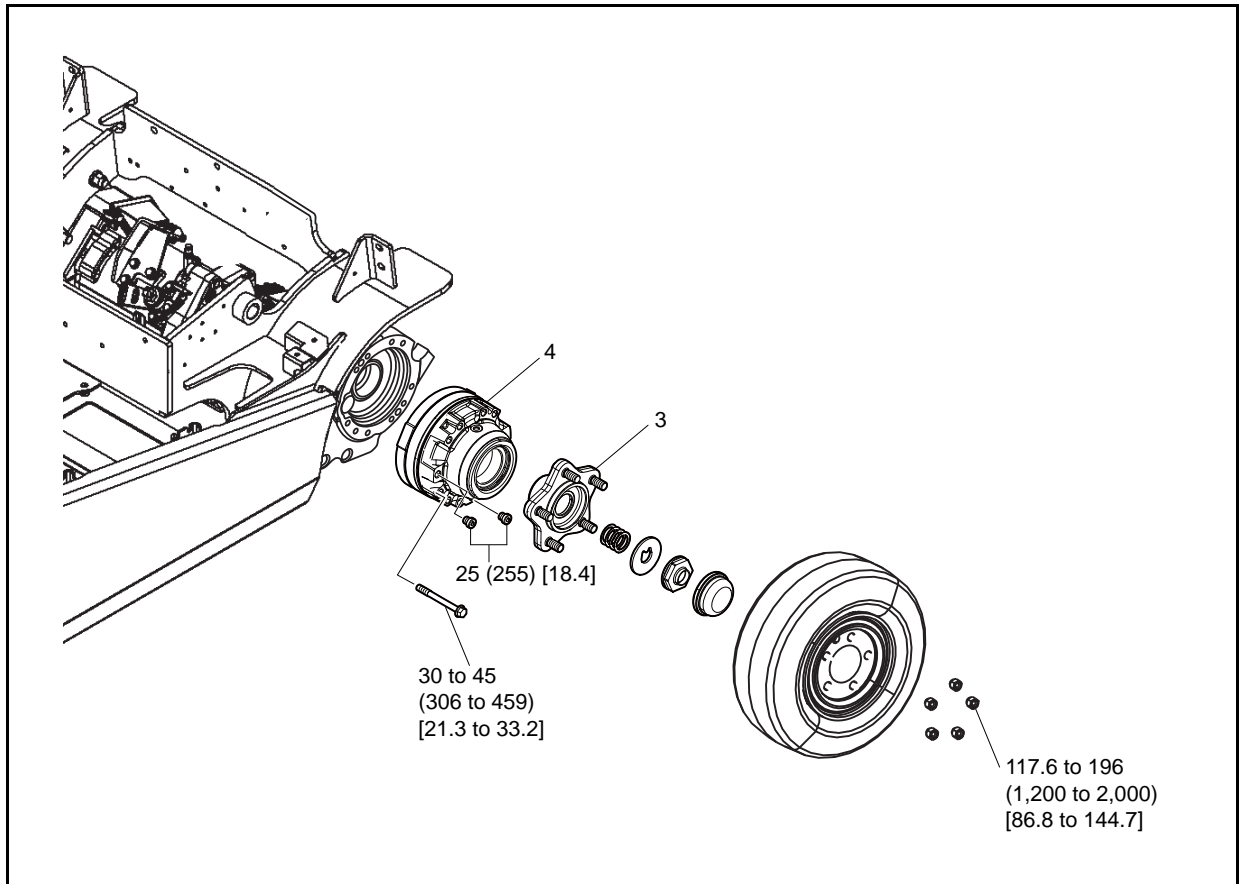

6

#### Removal Procedure

1. Jack up the vehicle and remove the front wheels. **[Point 1]**
2. Drain the gear oil. **[Point 2]**
3. Remove the front axle hub. **[Point 3]**
4. Remove the drive unit ASSY.

#### Installation Procedure

The installation procedure is the reverse of the removal procedure.

##### Type and quantity of gear oil:

Type	STD	ATF type T-4
	Cold storage type	
Quantity	0.43 ℓ (0.11 US gal)	

##### Type of grease:

STD	MP grease
Cold storage type	

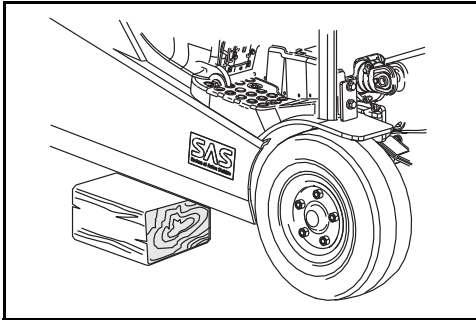

**Point Operations**

**[Point 1]**

Removal:

Always jack up the vehicle at the jack-up point. Jacking up the vehicle at other location is very dangerous.  
Always support the load of jacked-up vehicle with wooden blocks at specified points.

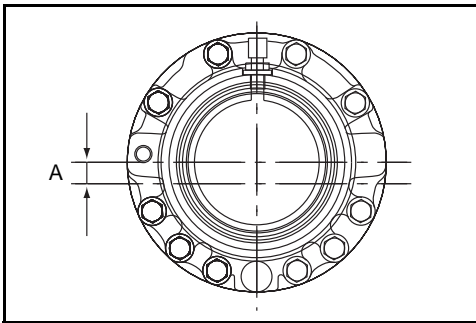

**[Point 2]**

Installation:

After installation, fill hypoid gear oil till the specified level.

**A=10 mm (0.39 in) or less**

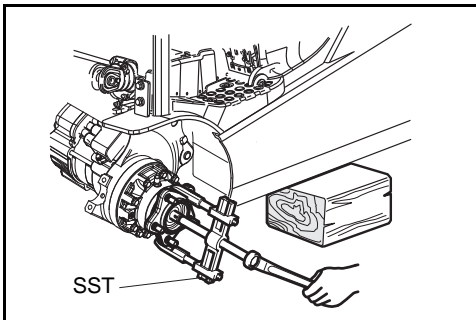

**[Point 3]**

Removal:

SST 09950-76014-71 (09950-40011)

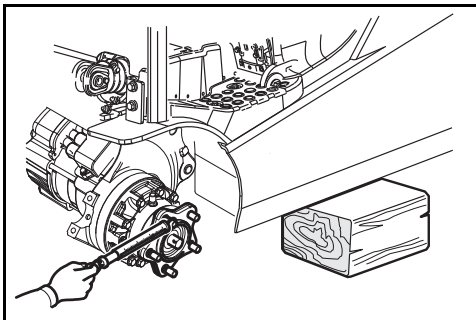

Inspection:

Measure the front axle hub starting force.

Models	Standard
8FBET, 8FBMT	27.2 to 62.9 (2.8 to 6.4) [6.0 to 14.1]

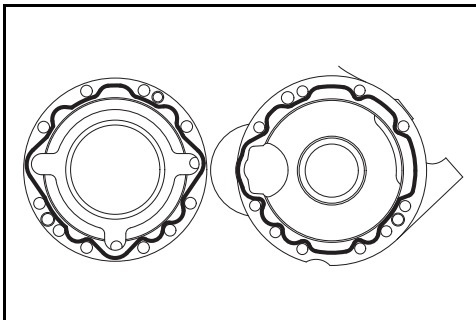

**[Point 4]**

Installation:

For installation, apply gasket sealant to the mating face with the drive unit. Be sure to remove the grease on the face.

Selant: 08826-76002-71 (08826-00080)

## DISASSEMBLY-INSPECTION-REASSEMBLY

T=N·m (kgf·cm) [ft·lbf]

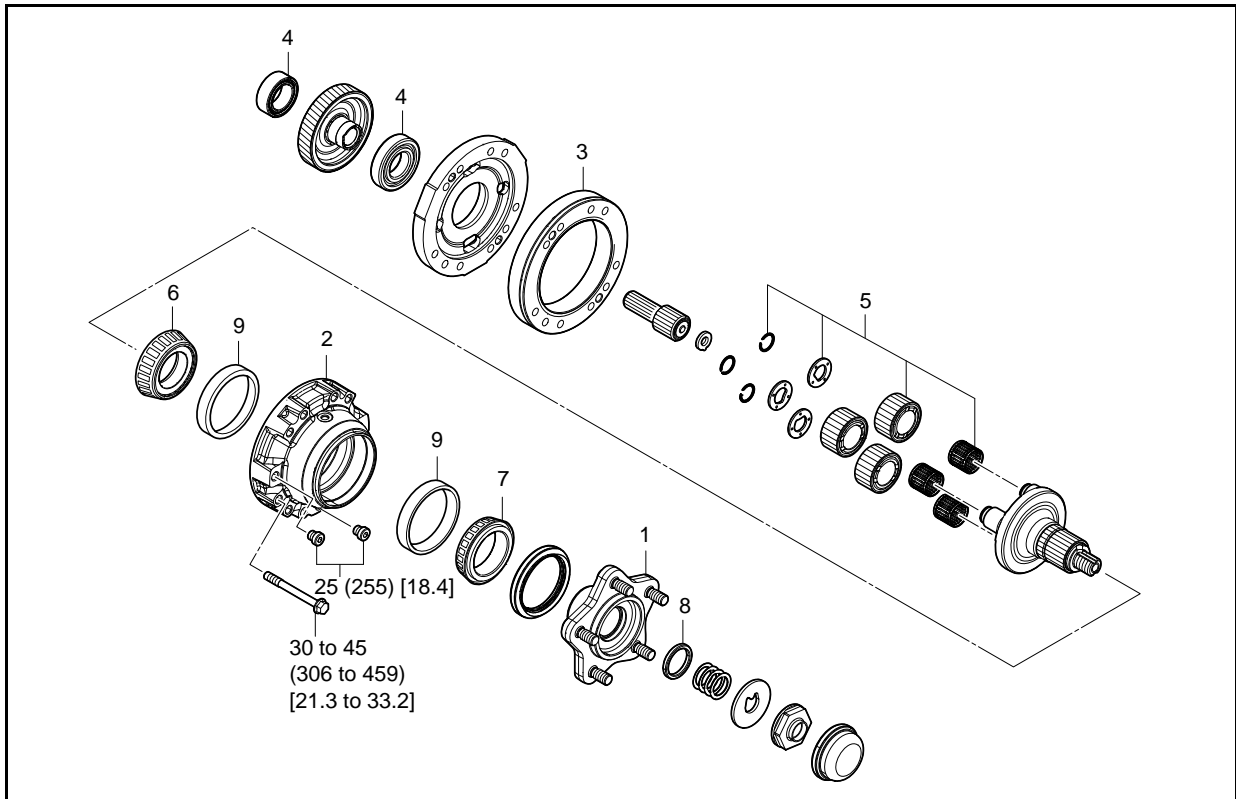
**Disassembly Procedure**

1. Remove the front axle hub. (See page 6-5)
2. Remove the mission cover.
3. Remove the internal gear. **[Point 1]**
4. Remove the idle gear bearing. **[Point 2]**
5. Remove the planetary gear. **[Point 3]**
6. Remove the axle shaft bearing. **[Point 4]**
7. Remove the front axle hub bearing. **[Point 5]**
8. Remove the coller. **[Point 6]**
9. Remove the outer race and inner race. **[Point 7]**

**Reassembly Procedure**

1. Install the idle gear bearing. **[Point 8]**
2. Install the planetary gear.
3. Install the axle shaft bearing. **[Point 9]**
4. Install the internal gear.
5. Measure the backlash of planetary gear. **[Point 10]**
6. Install the outer race and inner race. **[Point 11]**
7. Install the outer seal. **[Point 12]**
8. Install the axle hub. **[Point 13]**
9. Install the axle shaft. **[Point 14]**
10. Install the coller. **[Point 15]**
11. Adjustment preload torque of axle hub. **[Point 16]**
12. Staking of axle lock nut. **[Point 17]**
13. Install the axle hub cap. **[Point 18]**
14. Install the drive unit ASSY. (See page 6-5) **[Point 19]**

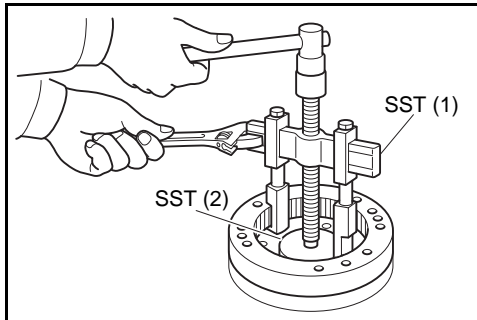

### Point Operations

#### [Point 1]

Disassembly:

Use the SST to remove the internal gear.

- SST 09950-76014-71 (09950-40011) ..... (1)  
 09950-76019-71 (09950-60020) ..... (2)

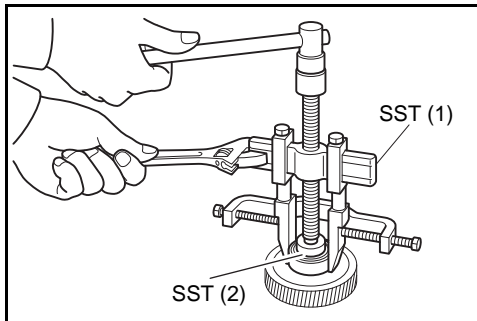

#### [Point 2]

Disassembly:

1. Use the SST to remove the inner bearing.

- SST 09950-76014-71 (09950-40011) ..... (1)  
 09950-76018-71 (09950-60010) ..... (2)

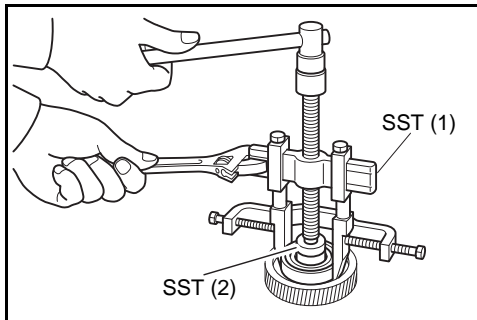

2. Use the SST to remove the outer bearing.

- SST 09950-76014-71 (09950-40011) ..... (1)  
 09950-76018-71 (09950-60010) ..... (2)

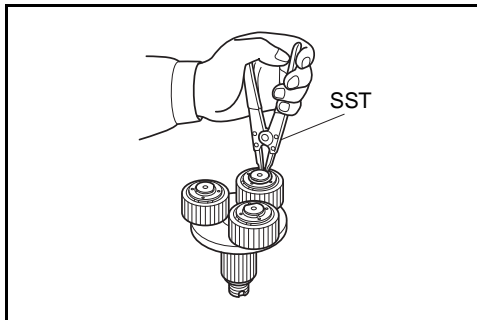

#### [Point 3]

Disassembly:

Use the SST to remove the planetary gear.

- SST 09905-76002-71 (09905-00012)

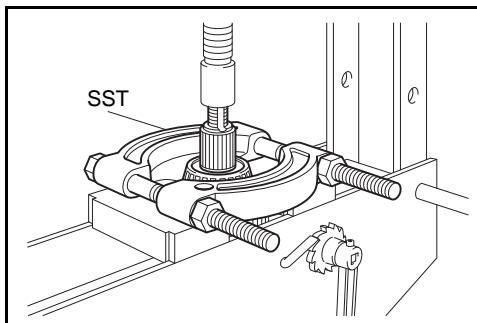

#### [Point 4]

Disassembly:

Use the SST and hand press to remove the axle shaft bearing.

- SST 09420-23002-71

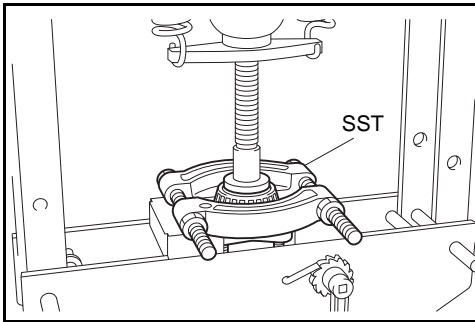
**[Point 5]**

Disassembly:

Use the SST and hand press to remove the axle hub bearing.

SST 09420-23002-71

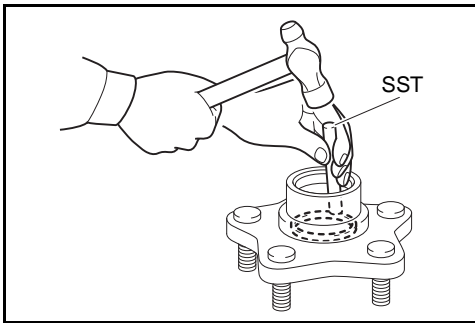
**[Point 6]**

Disassembly:

Use the SST to remove the collar.

SST 09700-30200-71

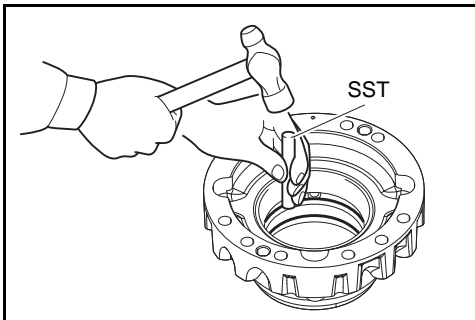
**[Point 7]**

Disassembly:

1. Use the SST to remove the outer race.

SST 09700-30200-71

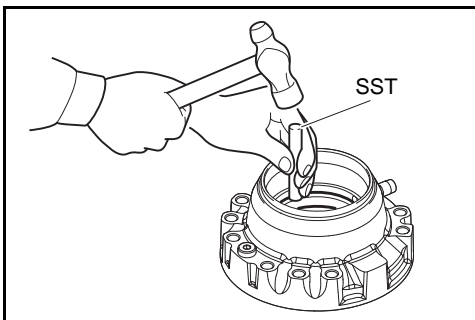

2. Use the SST to remove the inner race.

SST 09700-30200-71

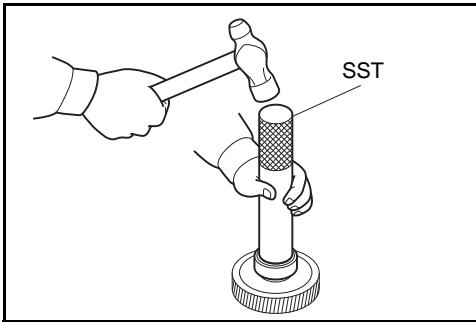

**[Point 8]**

Reassembly:

1. Use the SST to install the inner bearing.  
SST 09411-41800-71

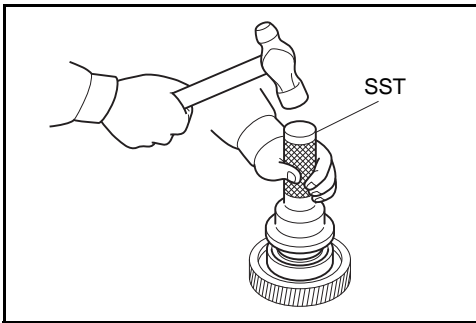

2. Use the SST to install the outer bearing.  
SST 09223-76005-71 (09223-46011)

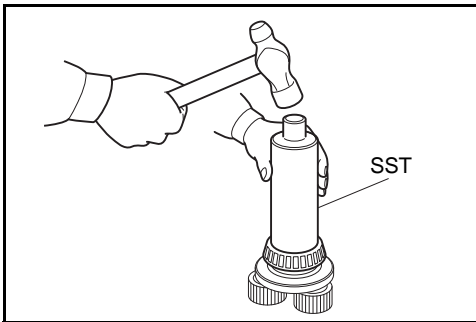

**[Point 9]**

Reassembly:

- Use the SST to install the axle shaft bearing.  
SST 09410-26600-71

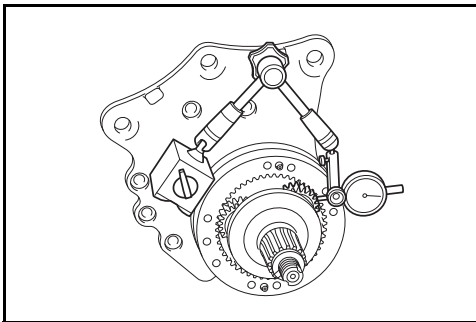

**[Point 10]**

Inspection:

Measure the backlash of the planetary gear, idle gear and ring gear.

**Standard: 0.2mm (0.008 in.) or less**

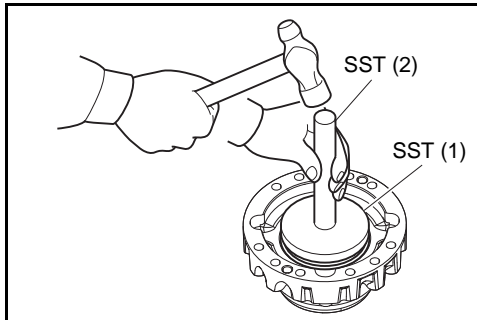
**[Point 11]**

Reassembly:

1. Use the SST to install the inner race.
 

SST 09331-13240-71.....	(1)
09950-76020-71 (09950-70010) .....	(2)

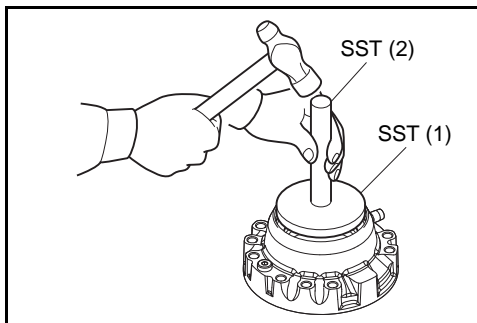

2. Use the SST to install the outer race.
 

SST 09331-13240-71.....	(1)
09950-76020-71 (09950-70010) .....	(2)

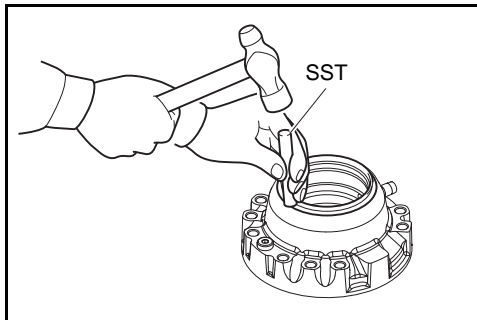
**[Point 12]**

Reassembly:

Use the SST to install the oil seal.

SST 09700-30200-71

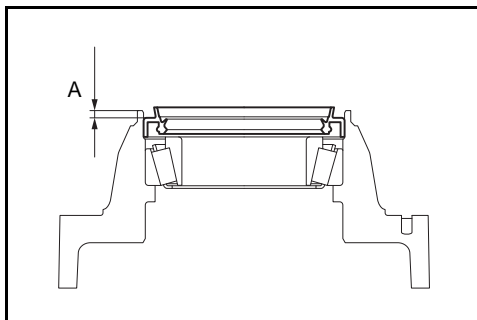
**Note:**

Drive in an oil seal up to the position shown in the figure on the left.

**Standard A: 3.5 ± 0.5 mm (0.14 ± 0.02 in.)**



**Suggest:**

**For more complete manuals. Please go to the home page.**

**<https://www.ebooklibonline.com>**

**If the above button click is invalid. Please download this document first, and then click the above link to download the complete manual.**

**Thank you so much for reading**

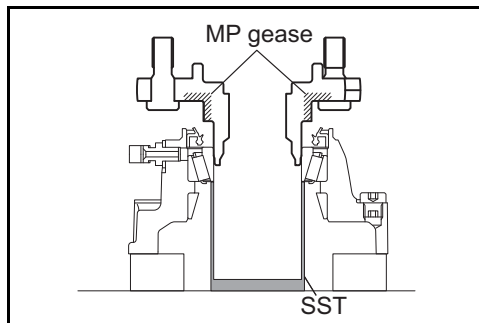

**[Point 13]**

Reassembly:  
Before mounting the axle hub, apply MP grease to the portions shown in the figure.

SST 09420-13130-71

**Note:**

**Be careful not to allow SST to touch the inner or outer race of the bearing.**

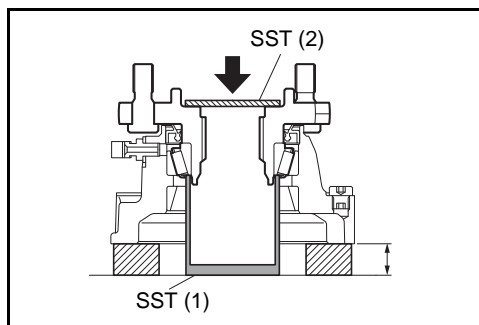

1. Use the SST and hand press to install the axle hub.

SST 09420-13130-71..... (1)  
09950-76019-71 (09950-60020) ..... (2)

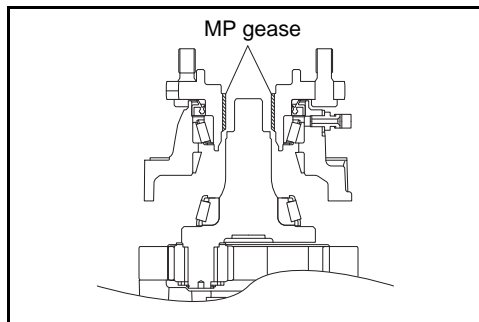

**[Point 14]**

Reassembly:

1. Before mounting the axle hub, apply MP grease to the portions shown in the figure.
2. Install the washer and hub nut.

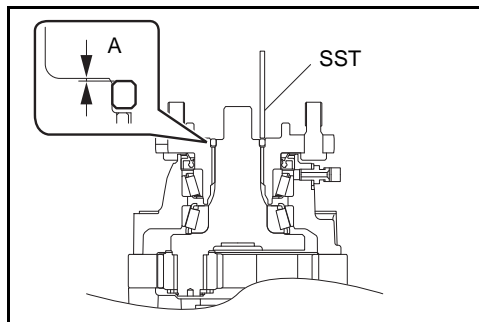

**[Point 15]**

Reassembly:

1. Use the SST to Install the collar.

SST 09700-30200-71

**Standard A: 0.5<sup>+0</sup><sub>-0.5</sub> mm (0.02<sup>+0</sup><sub>-0.02</sub> in.)**

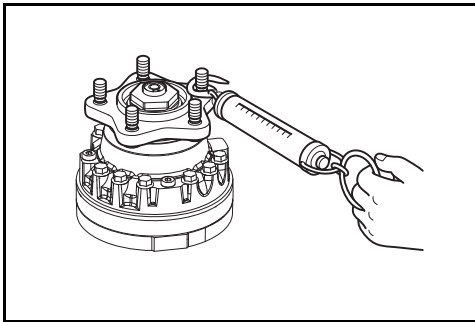
**[Point 16]**

Inspection:

1. Tighten the hub nut to 36.5 N·m (372 kgf·cm) [27 ft·lbf].
2. Turn the hub nut 4 or 5 turns to break in the bearing.
3. Tighten the hub nut to 215 N·m (2,193 kgf·cm) [159ft·bf].
4. Turn the hub nut 4 or 5 turns to break in the bearing.
5. Measure the starting power with a spring scale. Adjust the hub nut to bring the starting power into the standard range.

**Standard: 27.2 to 62.9 N (2.8 to 6.4 kg) [6.17 to 14.1 lbf]**

**Note:**

- Perform these measurements without mounting either the internal gear or the retainer.
- If the starting power is outside the standard range, make an adjustment with a shim.
- When loosening the hub nut, first loose it a little more than necessary by hammering the hub lightly, and then turn it in the tightening direction to adjust the tightness.

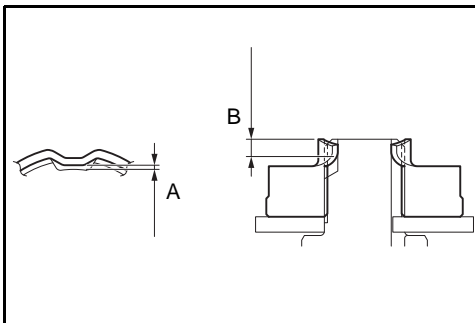
**[Point 17]**

Reassembly:

Caulk the hub nut with a pin punch and a chisel.

**Limit: A: 1 mm (0.04 in.) or less**  
**B: Approx. 5 mm (0.2 in.)**

**Note:**

To avoid cracking, bend the edge carefully around the corner.

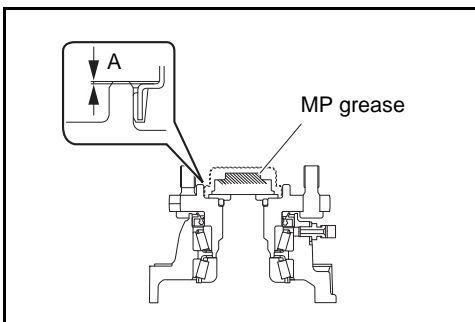
**[Point 18]**

Reassembly:

1. Apply MP grease to the portions shown in the figure.
2. Press-fit the hub cap to the position shown in the figure.

**Limit A: 0.5<sup>+0</sup><sub>-0.5</sub> mm (0.02<sup>+0</sup><sub>-0.02</sub> in.)**

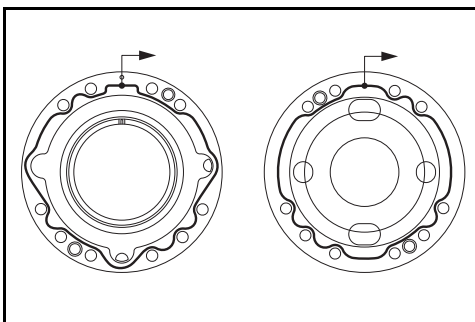
**[Point 19]**

Installation:

For installation, apply gasket sealant to the mating face with the drive unit. Be sure to remove the grease on the face.

Selant: 08826- 76002-71 (08826-00080)

**Note:**

- Be sure to apply grease from the starting point in the direction shown by the arrow.
- Pay attention to not dirty the screws with red paste.

**<https://www.ebooklibonline.com>**

Hello dear friend!

Thank you very much for reading.

Enter the link into your browser.

The full manual is available for immediate download.

**<https://www.ebooklibonline.com>**