



BT Svenska AB

# SERVICE MANUAL

TOYOTA 7FDF/FGF 15-35

INDEX

NAME	SECTION
<b>GENERAL</b>	<b>0</b>
<b>ENGINE</b>	<b>1</b>
<b>TRANSMISSION</b>	<b>2</b>
<b>PROPELLER SHAFT</b>	<b>3</b>
<b>DIFFERENTIAL</b>	<b>4</b>
<b>FRONT AXLE</b>	<b>5</b>
<b>REAR AXLE</b>	<b>6</b>
<b>STEERING</b>	<b>7</b>
<b>BRAKE</b>	<b>8</b>
<b>BODY</b>	<b>9</b>
<b>MATERIAL HANDLING SYSTEM</b>	<b>10</b>
<b>MAST</b>	<b>11</b>
<b>CYLINDER</b>	<b>12</b>
<b>OIL PUMP</b>	<b>13</b>
<b>OIL CONTROL VALVE</b>	<b>14</b>
<b>SAS</b>	<b>15</b>
<b>APPENDIX</b>	<b>16</b>

## GENERAL

**0**

	Page
EXTERIOR VIEWS .....	0-2
VEHICLE MODEL .....	0-3
FRAME NUMBER .....	0-4
HOW TO USE THIS MANUAL .....	0-5
EXPLANATION METHOD .....	0-5
TERMINOLOGY .....	0-6
ABBREVIATIONS .....	0-6
OPERATIONAL TIPS .....	0-7
HOISTING THE VEHICLE .....	0-8
CIRCUIT TESTER.....	0-9
STANDARD BOLT & NUT TIGHTENING	
TORQUE .....	0-11
BOLT STRENGTH TYPE IDENTIFICATION METHOD .....	0-11
TIGHTENING TORQUE TABLE .....	0-12
PRECOAT BOLTS .....	0-13
HIGH PRESSURE HOSE FITTING	
TIGHTENING TORQUE .....	0-13
WIRE ROPE SUSPENSION ANGLE LIST .....	0-14
SAFE LOAD FOR EACH WIRE ROPE	
SUSPENSION ANGLE .....	0-14
COMPONENTS WEIGHT .....	0-15
RECOMMENDED LUBRICANT	
QUANTITY & TYPES .....	0-16
SMÖRJSHEMA .....	0-18
PERIODISKT UNDERHÅLL .....	0-19
UTBYTE AV SMÖRJMEDEL	
OCH DELAR .....	0-25



# EXTERIOR VIEWS

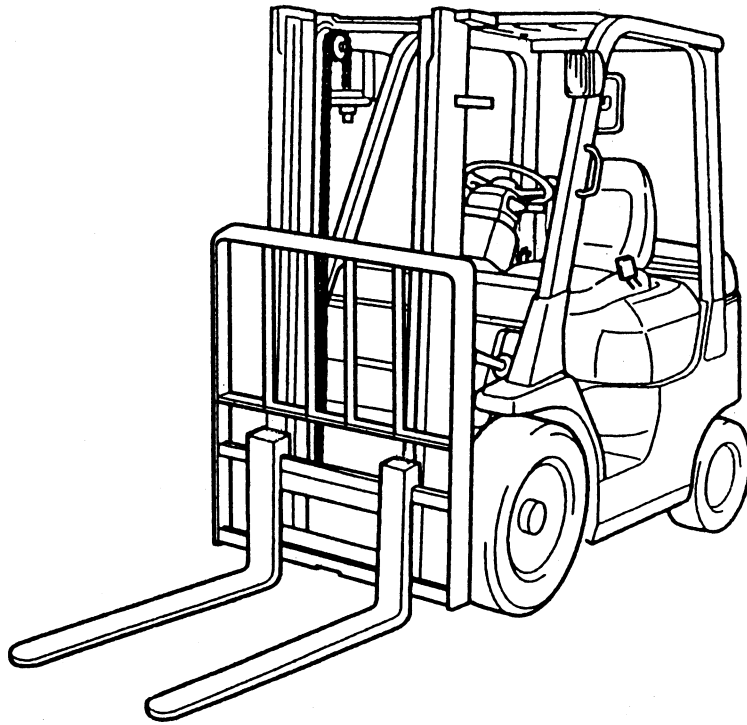

**<https://www.ebooklibonline.com>**

Hello dear friend!

Thank you very much for reading.

Enter the link into your browser.

The full manual is available for immediate download.

**<https://www.ebooklibonline.com>**

## VEHICLE MODEL

Classification		Vehicle Model	Transmission Type	Engine	
Series	Model				
1 ton series	1.5 ton model	42-7FGF15	T/C	4Y	Gasoline
		02-7FDF15	T/C	1DZ-II	Diesel
	1.75 ton model	42-7FGF18	T/C	4Y	Gasoline
		02-7FDF18	T/C	1DZ-II	Diesel
2 ton series	2.0 ton model	42-7FGF20	T/C	4Y	Gasoline
		62-7FDF20	T/C	1DZ-II	Diesel
		02-7FDF20	T/C	2Z	
	2.5 ton model	42-7FGF25	T/C	4Y	Gasoline
		62-7FDF25	T/C	1DZ-II	Diesel
		02-7FDF25	T/C	2Z	
3 ton series	3.0 ton model	02-7FGF30	T/C	4Y	Gasoline
		62-7FDF30	T/C	1DZ-II	Diesel
		02-7FDF30	T/C	2Z	
J3.5 ton series	J3.5 ton model	02-7FGJF35	T/C	4Y	Gasoline
		02-7FDJF35	T/C	2Z	Diesel



## FRAME NUMBER

### Frame No. Punching Position

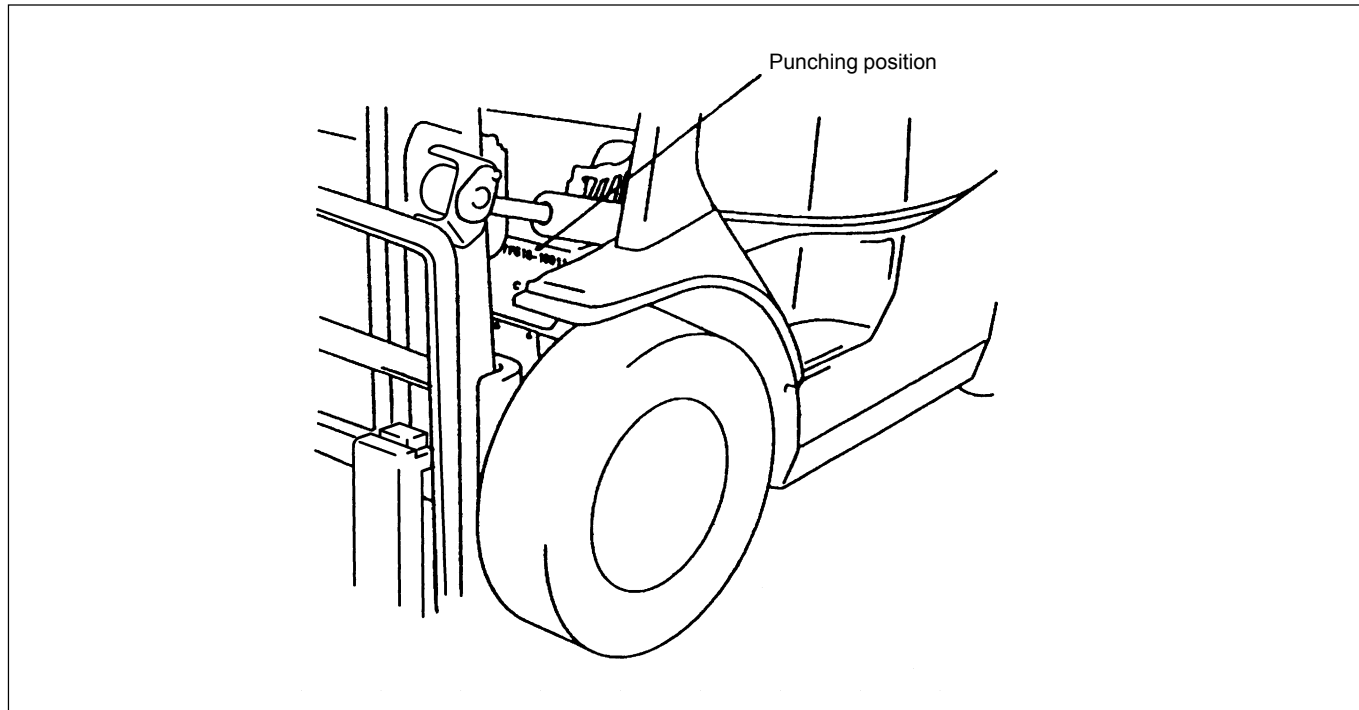

Series	Engine	Vehicle model	Punching format
1 ton series	4Y	42-7FGF15	407FGF18⑩10011
		42-7FGF18	
	1DZ-II	02-7FDF15	7FDF18⑩10011
		02-7FDF18	
2 ton series	4Y	42-7FGF20	407FGF25⑩10011
		42-7FGF25	
	2Z	02-7FDF20	7FDF25⑩10011
		02-7FDF25	
	1DZ-II	62-7FDF20	607FDF25⑩10011
		62-7FDF25	
3 ton, J3.5 ton series	4Y	02-7FGF30	7FGJF35⑩10011
		02-7FGJF35	
	2Z	02-7FDF30	7FDJF35⑩10011
		02-7FDJF35	
	1DZ-II	62-7FDF30	607FDF30⑩10011



## HOW TO USE THIS MANUAL

### EXPLANATION METHOD

#### 1. Operation procedure

(1) The operation procedure is described in either pattern A or pattern B below.

Pattern A: Explanation of each operation step with illustration.

Pattern B: Explanation of operation procedure by indicating step numbers in one illustration, followed by explanation of cautions and notes summarized as point operations.

Example of description in pattern B

### DISASSEMBLY·INSPECTION·REASSEMBLY Tightening torque unit T = N·m (kgf·cm) [ft·lbf]

- Step Nos. are partially sometimes omitted in illustrations.
- When a part requiring tightening torque instruction is not indicated in the illustration, the part name is described in the illustration frame.

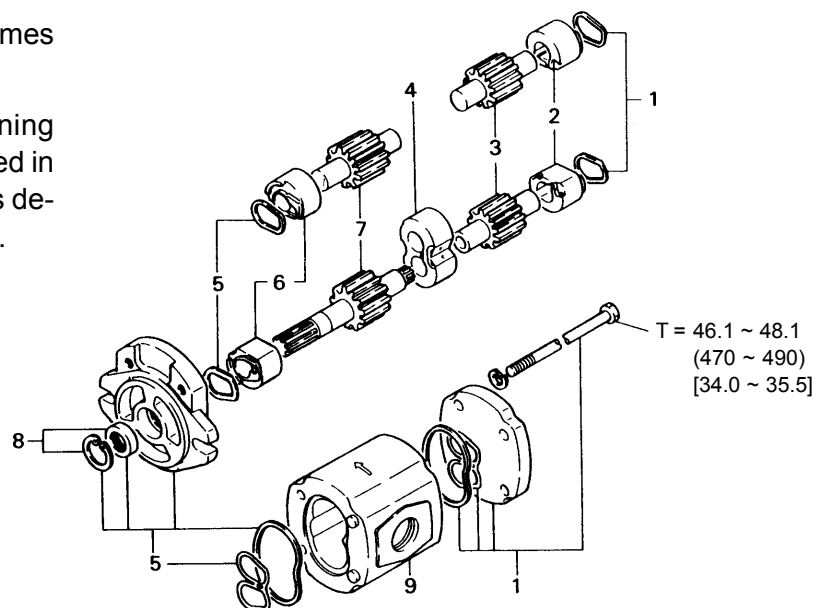

#### Disassembly Procedure

- 1 Remove the cover. **[Point 1]**
- 2 Remove the bushing **[Point 2]** ← Operation explained later
- 3 Remove the gear.

**Point Operations** Explanation of key point for operation with an illustration

#### **[Point 1]**



Disassembly: Put a match mark when removing the pump cover.

#### **[Point 2]**

Inspection: Measure the bush inside diameter.

**Limit: 19.12 mm (0.7528 in)**

## 2. How to read components figures

- (1) The components figure uses the illustration in the parts catalog for the vehicle model. Please refer to the catalog for checking the part name.  
The number at the right shoulder of each components figure indicates the Fig. number in the parts catalog.

(Example)

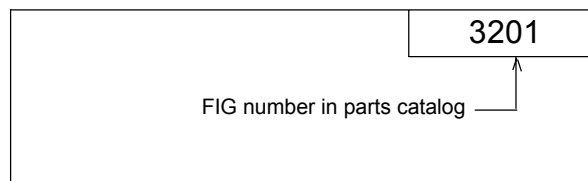

## 3. Matters omitted in this manual

- (1) This manual omits description of the following jobs, but perform them in actual operation:
- ① Cleaning and washing of removed parts as required
  - ② Visual inspection (partially described)

**TERMINOLOGY****Caution:**

**Important matters of which negligence may cause accidents. Be sure to observe them.**

**Note:**

**Important items of which negligence may cause accidents, or matters in operation procedure requiring special attention.**

Standard: Values showing allowable range in inspection and adjustment.

Limit: Maximum or minimum allowable value in inspection or adjustment.

**ABBREVIATIONS**

Abbreviation (code)	Meaning	Abbreviation (code)	Meaning
ASSY	Assembly	SAS	System of active stability
LH	Left hand	SST	Special service tool
LLC	Long life coolant	STD	Standard
M/T	Manual transmission	T =	Tightening torque
NMR	No-load maximum speed	T/C	Torque converter & transmission
OPT	Option	○ ○ T	Number of teeth (○ ○)
O/S	Oversize	U/S	Undersize
PS	Power steering	W/	With
RH	Right hand	L/	Less
SAE	Society of Automotive Engineers (USA)		



# ENGINE ASSY

## REMOVAL·INSTALLATION

T = N·m (kgf·cm) [ft·lbf]

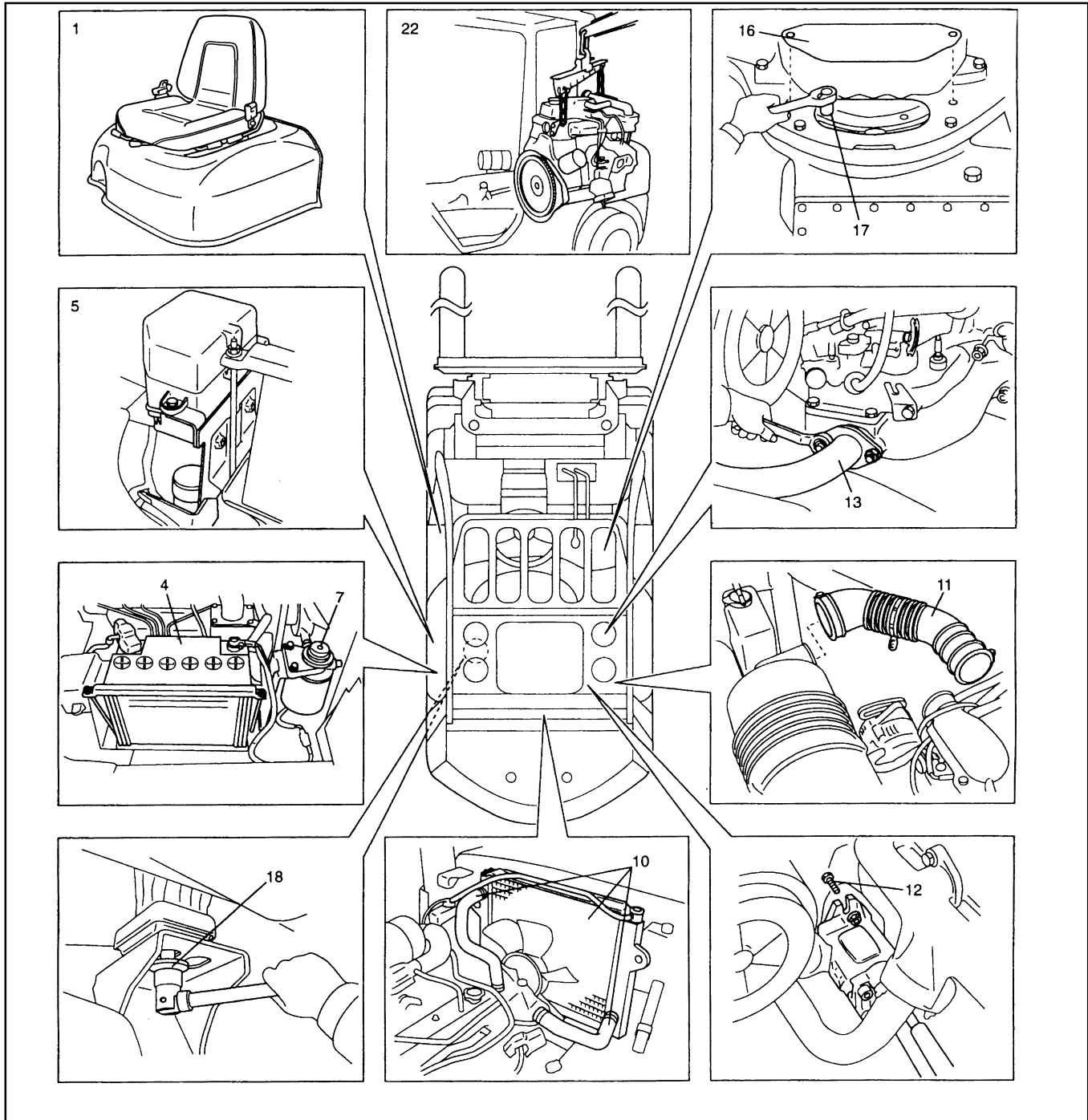

Engine mounting nut	T = 53.9 ~ 99.0 (550 ~ 1010) [39.8 ~ 73.1]
End plate set bolt	T = 49.0 ~ 78.5 (500 ~ 800) [36.2 ~ 57.9]
Drive plate set bolt (for connecting engine crankshaft)	4Y: T = 56.9 ~ 64.7 (580 ~ 660) [42.0 ~ 47.7] 1DZ-II·2Z: T = 76.5 ~ 93.2 (780 ~ 950) [56.4 ~ 68.7]
Drive plate set bolt (for connecting torque converter)	T = 14.7 ~ 21.6 (150 ~ 220) [10.9 ~ 15.9]
Torque converter housing set bolt	T = 29.4 ~ 44.1 (300 ~ 450) [21.7 ~ 32.6]



---

## Removal Procedure

- 1 Remove the engine hood. (See p. 9-5.)
- 2 Remove the toe board.
- 3 Drain coolant.
- 4 Remove the battery and battery tray.
- 5 Remove the relay block and electrical parts plate set bolts to free them.
- 6 Disconnect the accelerator wire and fuel hose. **[Point 1]**
- 7 Diesel Vehicle:  
Remove the sedimenter bracket set bolt to free the bracket.
- 8 Disconnect connectors and wiring harness clamps around the engine.
- 9 Disconnect the torque converter cooler hose. **[Point 2]**
- 10 Remove the radiator.
- 11 Disconnect the air cleaner hose.
- 12 Remove the oil pump set bolts to free the pump.
- 13 Disconnect the exhaust pipe.
- 14 Disconnect the wiring from the starting motor.
- 15 Remove the under cover.
- 16 Remove the cover plate.
- 17 Remove 6 drive plate set bolts.
- 18 Remove the engine ASSY mounting nuts.
- 19 Slightly hoist the engine. **[Point 3]**
- 20 Support the torque converter housing with wooden blocks.
- 21 Separate the torque converter housing and engine. **[Point 4]**
- 22 Remove the engine ASSY with drive plate and torque converter end plate.
- 23 Remove the drive plate.
- 24 Remove the torque converter end plate.
- 25 Remove the starting motor.

## Installation Procedure

The installation procedure is the reverse of the removal procedure.

### Note:

- **Apply sealant (08833-00080) before tightening the drive plate set bolt (for connecting engine crankshaft).**
- **Bleed air from the fuel system after installation of the engine ASSY. (For diesel vehicle) (See p. 1-11.)**



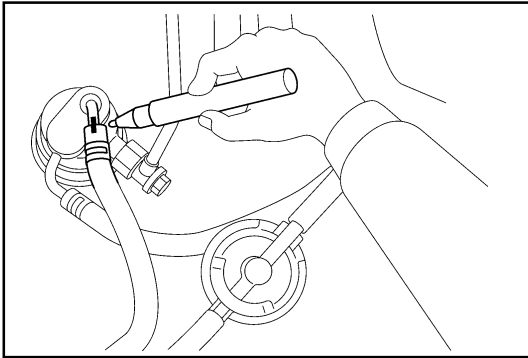

## Point Operations

### [Point 1]

Removal:

Put a match marks on the fuel hose and the coupler.

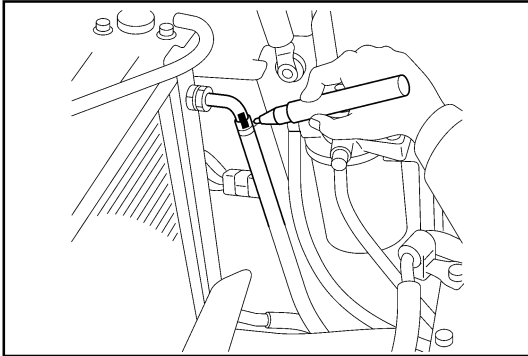

### [Point 2]

Removal:

Put a match mark on the radiator and torque converter cooler hose.

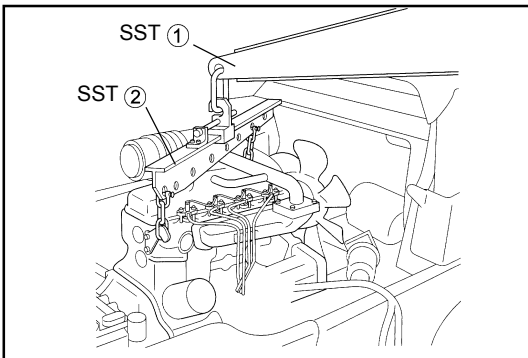

### [Point 3]

Removal·Installation:

SST 09010-20111-71 --- ①

09010-23320-71 --- ②

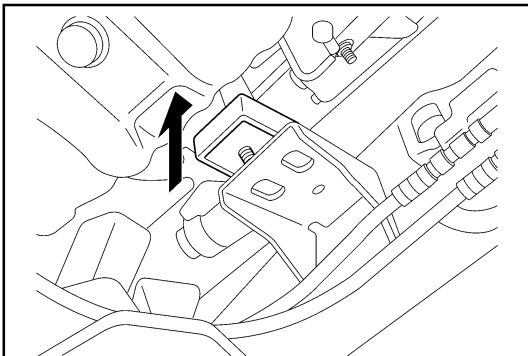

Removal:

Tentatively hoist up until the mounting bolt completely comes out from the hole in the frame.

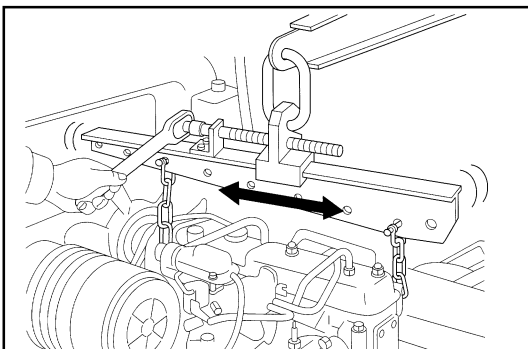

### [Point 4]

Removal:

Use a straight-edge screwdriver for separation. If the fitting is too tight, change the SST hook position and adjust the engine angle for easier separation.

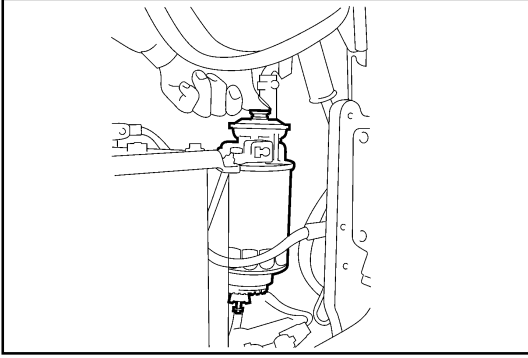

## AIR BLEEDING FROM FUEL SYSTEM (DIESEL VEHICLE)

1. Operate the hand pump of the fuel filter until the pump operating force becomes heavy.

## ENGINE SPEED INSPECTION AND ADJUSTMENT

### Note:

Warm up the engine, set the vehicle to the following conditions, and conduct inspection and adjustment.

Coolant temperature: 80°C (176°F) or more, engine oil: 70°C (158°F) or more, operating oil temperature: 50°C (122°F) or more, auto choke in release state (4Y engine)

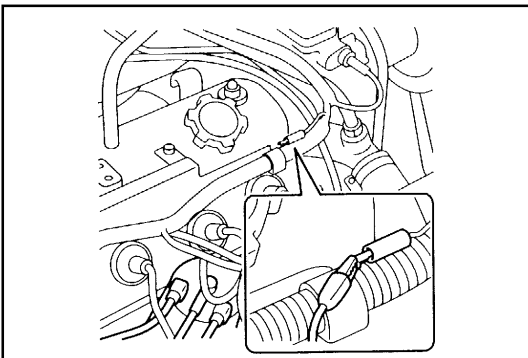

### 4Y ENGINE

#### Idling speed and idle up speed inspection and adjustment

<Gasoline Vehicle>

1. Install the engine speedometer.

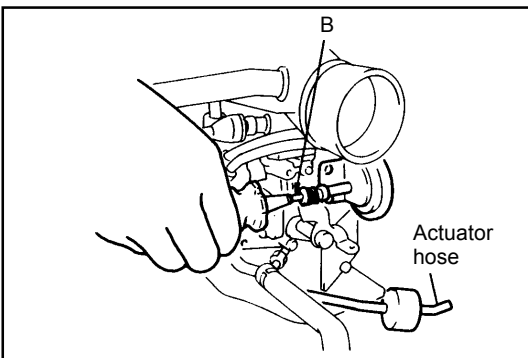

2. Disconnect the idle up actuator and inspect the idle up speed.

**Standard: 1000 ± 30 rpm**

3. If the measured value is out of the specified range, adjust by turning adjusting screw B.
4. Connect the idle up actuator.

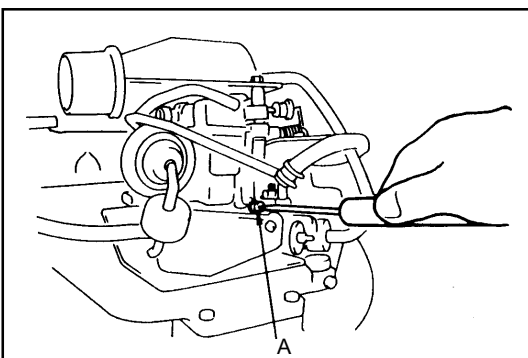

5. Check the idling speed.

**Standard: 750 <sup>+50</sup>/<sub>0</sub> rpm**

6. If the measured value is out of the specified range, adjust by adjusting screw A.
7. If the speed is still higher after adjustment in 3 above, adjust using the following procedure:

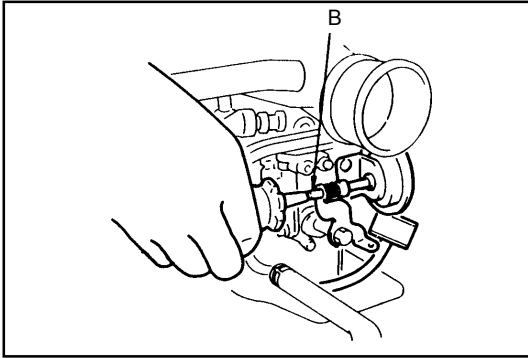

- (1) If the auto choke cam is contacting although the coolant temperature is as specified above, replace the auto choke.
- (2) If the idle up actuator rod and adjusting screw B are in contact with each other, turn adjusting screw B counterclockwise.

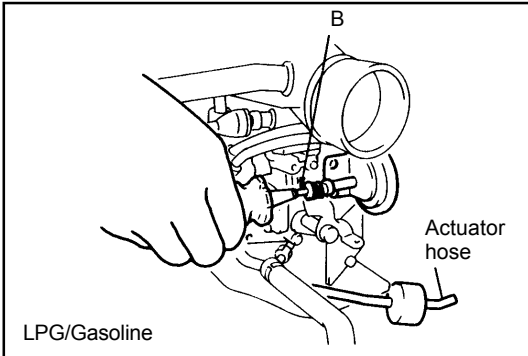

<LPG/Gasoline or LPG>

1. Install the engine speedometer.
2. Disconnect the idle up actuator and inspect the idle up speed.

**Standard:**

**LPG/Gasoline: 1000 ± 30 rpm**

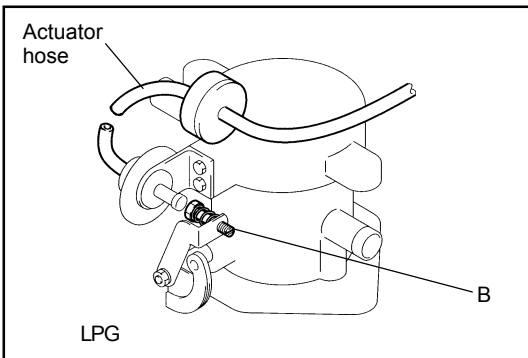

**LPG: 1400 ± 30 rpm**

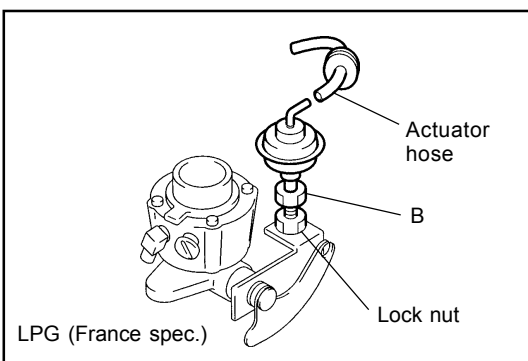

**LPG (France spec.): 1400 ± 30 rpm**

3. If the measured value is out of the specified range, adjust by turning adjusting screw B. Loosen the lock nut before adjustment in case of the LPG engine vehicle (France spec.).
4. Connect the idle up actuator.
5. Check the idling speed.

**Standard:**

**LPG/Gasoline: 750  $\begin{smallmatrix} +50 \\ -0 \end{smallmatrix}$  rpm**

**LPG: 800  $\begin{smallmatrix} +50 \\ -0 \end{smallmatrix}$  rpm**

**LPG (France spec.): 750  $\begin{smallmatrix} +50 \\ -0 \end{smallmatrix}$  rpm**



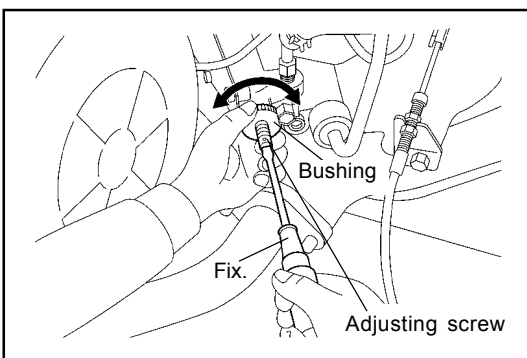
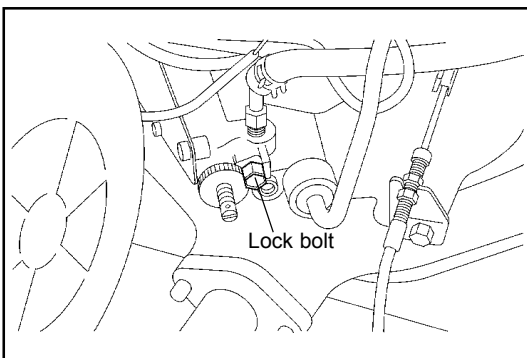
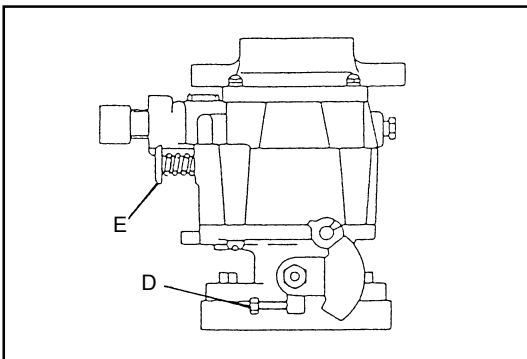
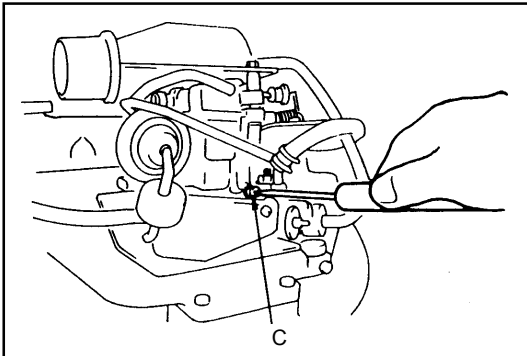
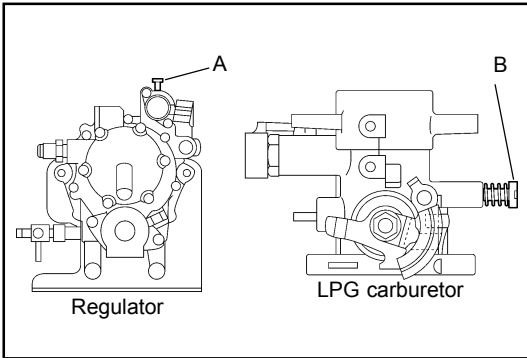

6. If the measured value is out of the specified range, make adjustment according to the following procedure:
  - (1) Make adjustment by turning adjusting screw B (LPG vehicle) or C (LPG/gasoline vehicle). (If less than the standard, turn adjusting screw A counterclockwise beforehand.)
  - (2) Slowly turn adjusting screw A clockwise or counterclockwise until the maximum speed is obtained.
  - (3) Determine the positions of adjusting screws B and C by repeating steps (1) and (2) until the value obtained in step (2) satisfies the standard.
  - (4) Slowly turn adjusting screw A clockwise until the CO concentration becomes 2 to 3%, and then turn it 45 degrees counterclockwise from the position where the speed begins to drop.

LPG (France spec.)

- (1) Make adjustment by turning adjusting screw D (LPG vehicle). (If less than the standard, turn adjusting screw E clockwise beforehand.)
- (2) Determine the position of adjusting screw D by repeating step (1) until the value obtained in step (1) satisfies the standard.
- (3) Slowly turn adjusting screw E counter-clockwise until the CO concentration becomes 2 to 3%, and then turn it 45 degrees counterclockwise from the position where the speed begins to drop.

**No-load Maximum Speed Inspection-Adjustment**  
 <Gasoline, LPG or LPG/Gasoline Vehicle>

1. Install the engine speedometer.
2. Inspect and adjust the no-load static maximum speed.
  - (1) Measure the speed when the accelerator pedal is fully depressed.

**Standard:**

**4Y engine:**

**1-2 ton series: ..... 2600 ± 50 rpm**

**3-J3.5 ton series: ..... 2800 ± 50 rpm**

- (2) If the measured value does not satisfy the standard, make adjustment as follows:
  - ① Remove the seal and loosen the lock bolt.
  - ② Fully depress the accelerator pedal.
  - ③ Turn the bushing for adjustment, while holding the adjusting screw of the air governor immovable with a straight-edge screwdriver.



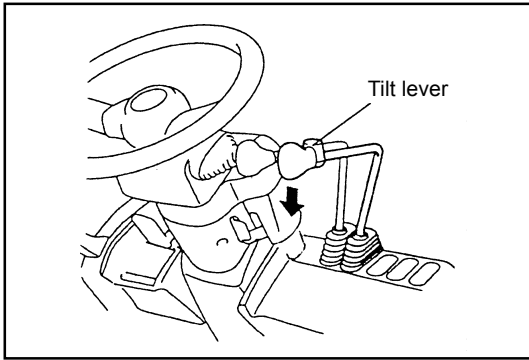

3. Check and adjust relief down.
  - (1) Operate the tilt lever fully backward with the engine running at the maximum speed, and measure the decrease in speed (relief down) upon full relief.

**Standard: Within 300 rpm**

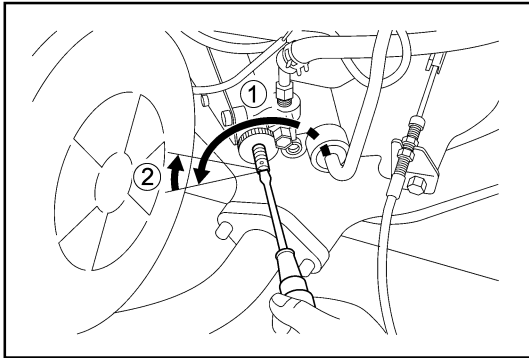

- (2) If the measured value is out of the standard range, make adjustment according to the following procedure:
  - ① Turn the adjusting screw counterclockwise to decrease relief down.
  - ② Return the screw by 1/10 of a turn to eliminate twisting of the spring in the air governor.
  - ③ Adjust the no-load maximum speed.
  - ④ Repeat steps ①, ② and ③ until the measured value satisfies the standard.

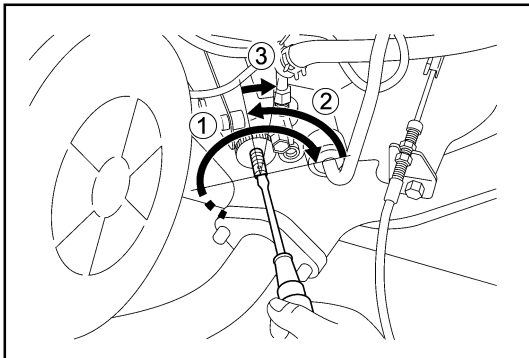

4. Check and adjust hunting.
  - (1) Check for hunting upon tilt relief at the no-load maximum speed.
  - (2) If hunting occurs a few times or more, make adjustment according to the following procedure:
    - ① Turn the adjusting screw clockwise by 1/2 of a turn or more.
    - ② Return the screw counterclockwise by 1/4 of a turn.
    - ③ Finally, turn it by 1/10 of a turn to eliminate twisting of the spring in the air governor.
    - ④ Adjust the no-load maximum speed.
    - ⑤ Repeat steps ① through ④ until hunting occurs no more.
5. Repeat adjustments in steps 2 to 4 until respective standards are satisfied.
6. Seal the lock bolt.

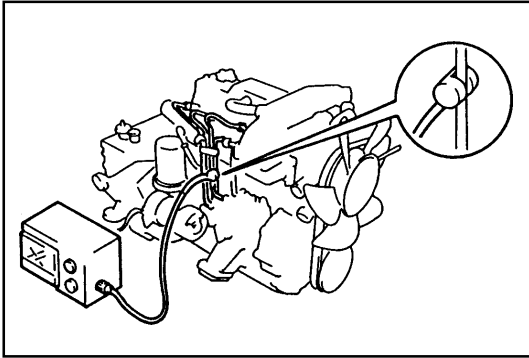

## 1DZ-II·2Z ENGINE

### Idle Speed Inspection·Adjustment

1. Install the engine speedometer.

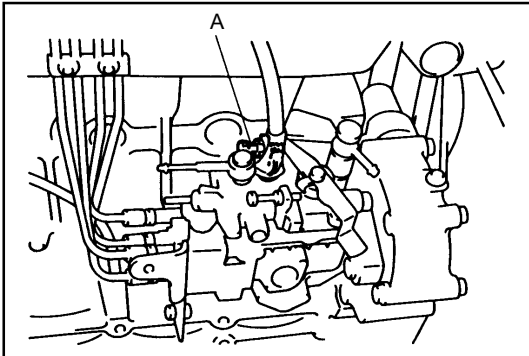

2. Check the idle speed.

**Standard: 750 ± 25 rpm**

3. If the measured value is out of the standard, loosen the lock nut and make adjustment by turning adjusting screw A.

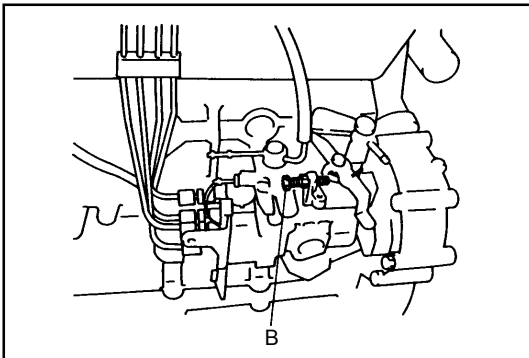

### No-load Maximum Speed Inspection·Adjustment

1. Install the engine speedometer.
2. Inspect and adjust the no-load maximum speed.
  - (1) Measure the speed when the accelerator pedal is fully depressed.

**Standard:**

**1DZ-II engine:**

1 ton series: ..... 2600 ± 50 rpm

**Vehicle speed control**

system spec.: ..... 2600 ± 50 rpm

2·3 ton series: ..... 2800 ± 50 rpm

**2Z engine:** ..... 2400 ± 50 rpm

- (2) If the measured value does not satisfy the standard , make adjustment as follows:

- ① Remove the seal and loosen the lock nut.
- ② Make adjustment by turning adjusting screw B.

3. Check and adjust relief down.

- (1) Operate the tilt lever fully backward with the engine running at the maximum speed and measure the decrease in speed (relief down) upon full relief.

**Standard: Within 200 rpm**

4. Seal the adjusting screws after the end of adjustment.

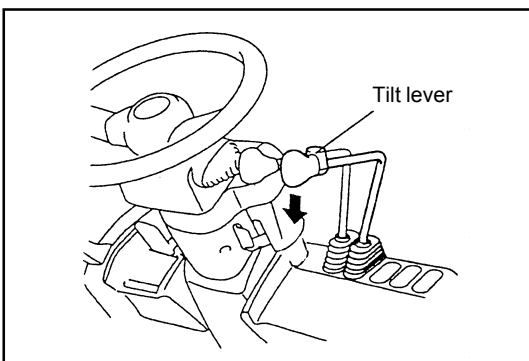

# AIR CLEANER

## SPECIFICATIONS

		Single (STD)	Double (OPT)
Type		Cyclone type	←
Size		7-inch	←
Intake type		Fresh air introduction type	←
Filtering area	cm <sup>2</sup> (in <sup>2</sup> )	14600 (2263)	Outer: 18600 (2883)
			Inner: 510 (79.1)
Others		With evacuator valve	←

## COMPONENTS

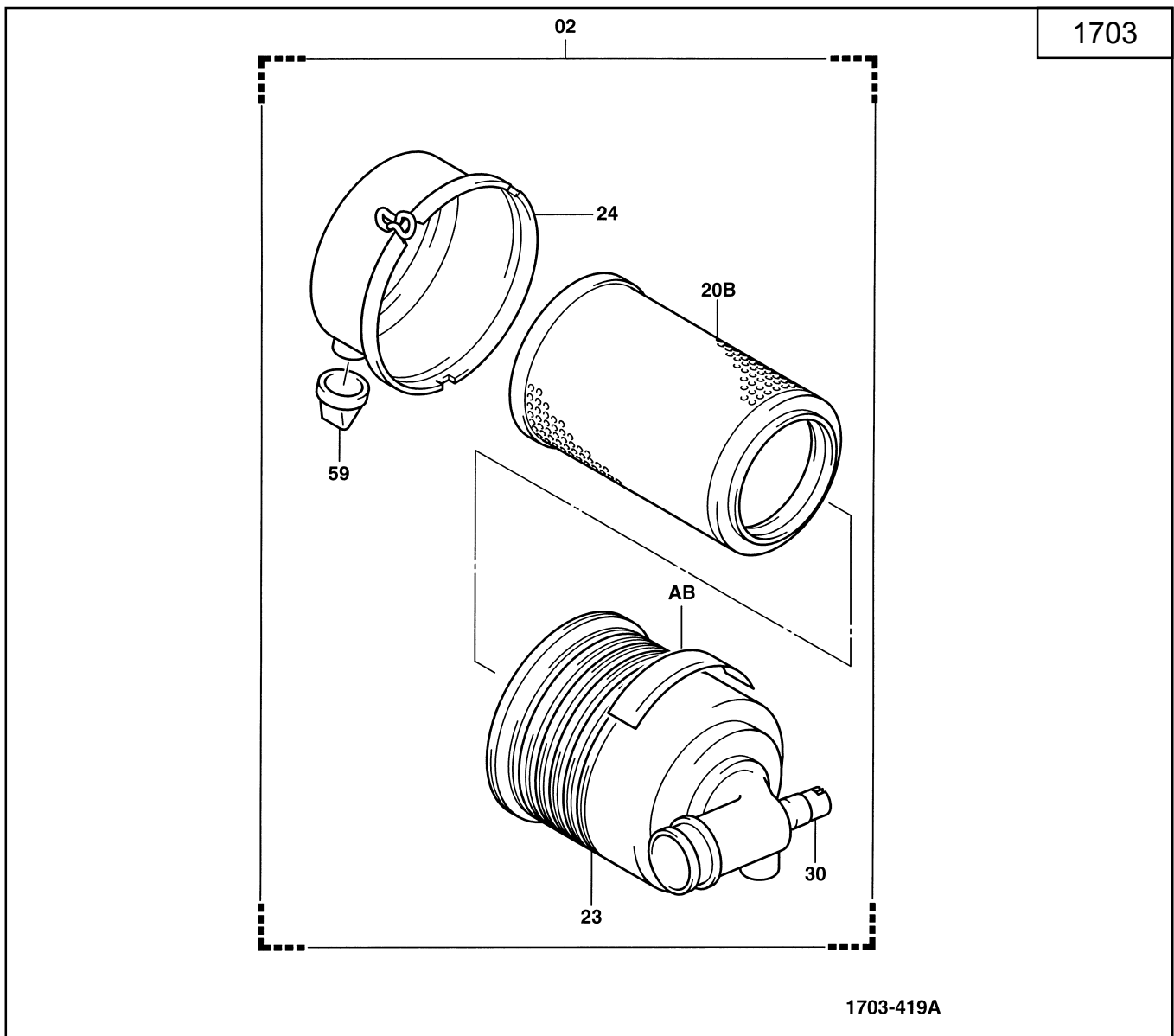

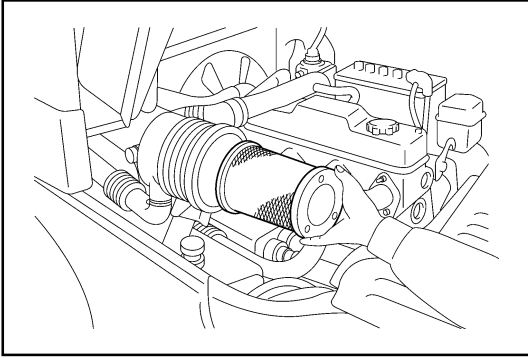

## AIR CLEANER CLEANING-INSPECTION

1. Open the engine hood.
2. Remove the element.

**Note:**

**In case of the double element type (OPT), do not remove the inner element for other than replacement.**

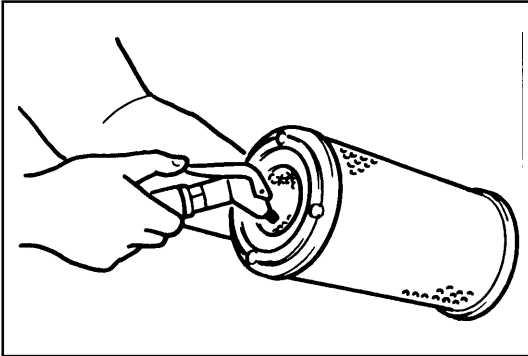

3. Clean the element.
  - (1) For ordinary cleaning, blow with compressed air [690 kPa (7kgf/cm<sup>2</sup>) [100 psi] or less] vertically along the pleats from the inside of the element. If heavily contaminated, washing is possible.
  - (2) Element washing method  
Dissolve neutral detergent in tepid water (approx. 40°C (104°F)) and immerse the element in it for about 30 minutes. Then, rinse the element well with clear water. [Water pressure: 275 kPa (2.8 kgf/cm<sup>2</sup>) [40 psi] or less]  
After washing, naturally dry the element or dry the element with a dryer (cold air).

**Note:**

- Do not damage the element during washing.
  - Never use compressed air or hot air for drying.
4. Clean the evacuator valve (dust discharge valve).
    - (1) Hold the tip end of the evacuator valve and discharge dust and dirt from the inside of the valve.
  5. Inspect the element.
    - (1) After cleaning, place an electric bulb in the element to inspect any damage in the element. If any pinhole, tear or damage is found, replace it with a new element.
  6. Element replacement  
Replace the element after it is washed six times or generally at intervals of 12 months.

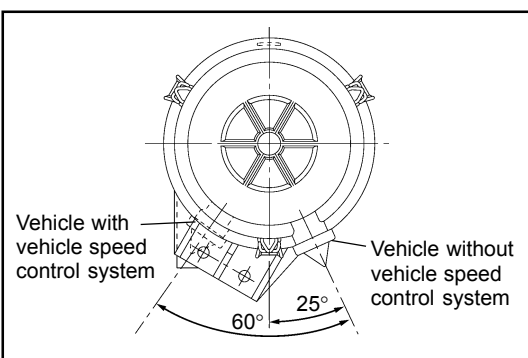
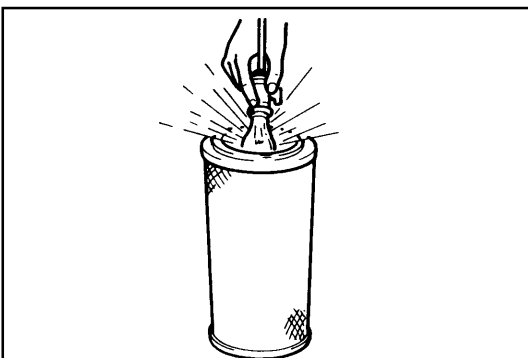
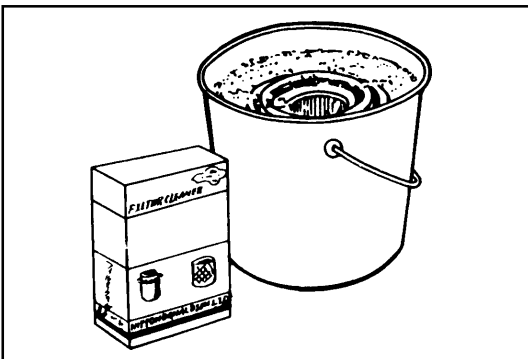

7. Install the element.
  - (1) Install the evacuator valve in the illustrated direction.





## SPECIFICATIONS

Type		Crossflow
Fin type		Corrugated fin
Coolant capacity (in radiator)		See the table below
Cap opening pressure	kPa (kgf/cm <sup>2</sup> ) [psi]	88 ± 14.7 (0.9 ± 0.15) [13 ± 2.1]
Others		Built in torque converter cooler (torque converter model)

## COOLANT CAPACITY AND ANTIFREEZE TABLE

Unit: ℓ (US gal)

		Radiator capacity	Total amount of coolant	LLC mixing ratio at 30% (to - 15°C (5°F))	LLC mixing ratio at 50% (to - 35°C (-31°F))	Antirust mixing at 5%
1 ton series	4Y	2.5 (0.66)	7.4 (1.95)	2.2 (0.58)	3.7 (0.98)	0.4 (0.11)
	1DZ-II	2.5 (0.66)	5.9 (1.56)	1.8 (0.48)	3.0 (0.79)	0.3 (0.08)
2 ton series	4Y	3.7 (0.98)	9.3 (2.46)	2.8 (0.74)	4.7 (1.24)	0.5 (0.13)
	1DZ-II	3.7 (0.98)	8.3 (2.19)	2.5 (0.66)	4.2 (1.11)	0.4 (0.11)
	2Z	3.7 (0.98)	9.0 (2.37)	2.7 (0.71)	4.5 (1.19)	0.5 (0.13)
3 ton series	4Y	3.7 (0.98)	9.5 (2.51)	2.9 (0.77)	4.8 (1.27)	0.5 (0.13)
	1DZ-II	3.7 (0.98)	8.2 (2.16)	2.5 (0.66)	4.1 (1.08)	0.4 (0.11)
	2Z	3.7 (0.98)	8.8 (2.32)	2.6 (0.69)	4.4 (1.16)	0.4 (0.11)
J3.5 ton series	4Y	3.7 (0.98)	9.5 (2.51)	2.9 (0.77)	4.8 (1.27)	0.5 (0.13)
	2Z	3.7 (0.98)	8.8 (2.32)	2.6 (0.69)	4.4 (1.16)	0.4 (0.11)

### Note:

- The total amount of coolant does not include the capacity of the reservoir tank.
- Reservoir tank capacity: 0.6ℓ (0.16 US gal) (at FULL mark position)





**Suggest:**

**For more complete manuals. Please go to the home page.**

**<https://www.ebooklibonline.com>**

**If the above button click is invalid. Please download this document first, and then click the above link to download the complete manual.**

**Thank you so much for reading**

# MUFFLER & EXHAUST PIPE COMPONENTS

1702

Gasoline model

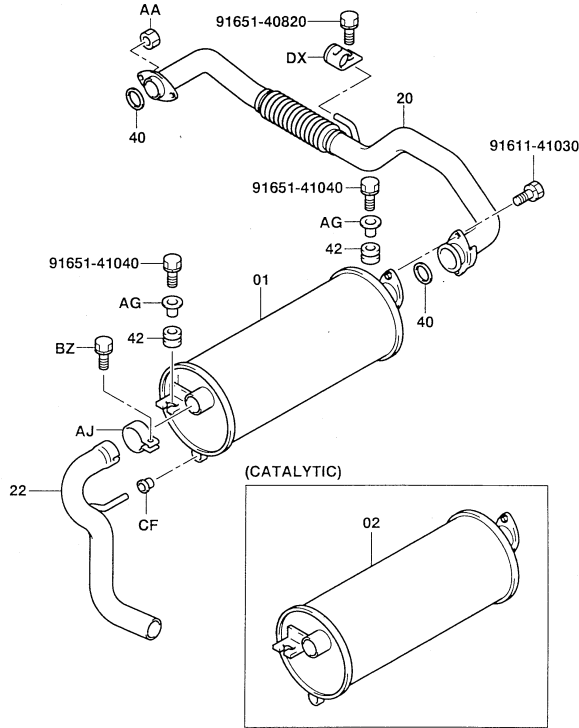

1702-357

Diesel model

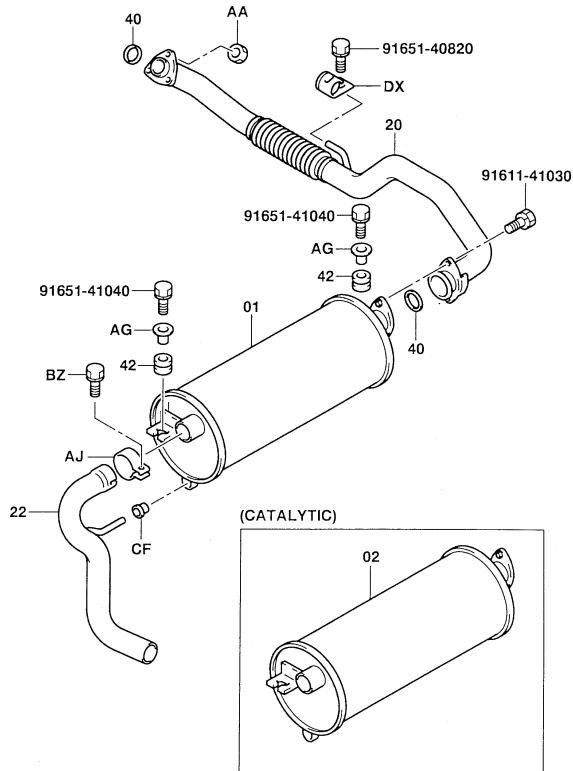

1702-356



## REMOVAL•INSTALLATION

### Note:

The muffler can be removed by either of the two methods shown below.

- ① Remove the muffler after removing the counterweight.
  - ② Remove the muffler after removing the radiator W/counterweight.
- Here, method ① is explained.

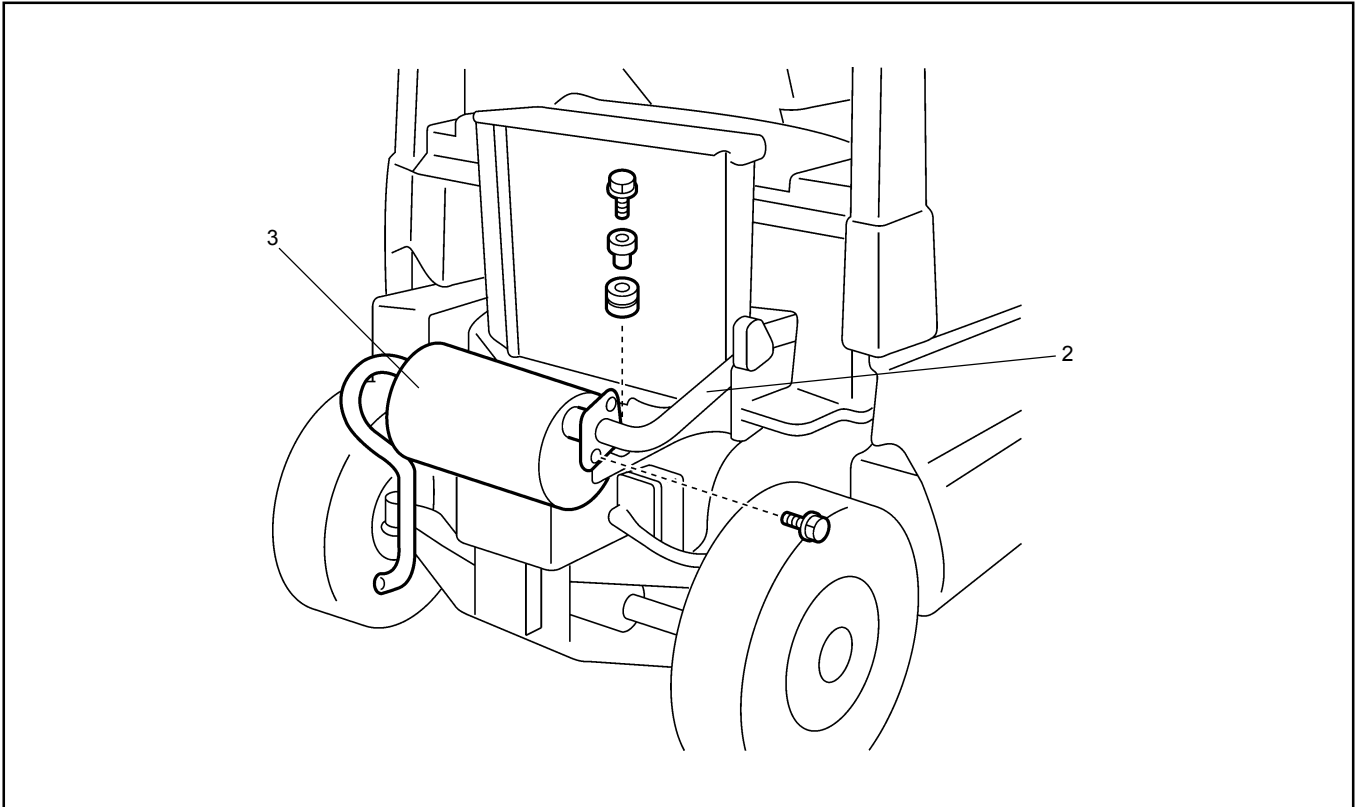

### Removal Procedure

- 1 Remove the counterweight. (See p. 9-6.)
- 2 Disconnect the exhaust pipe.
- 3 Remove the muffler W/tail pipe.
- 4 Disconnect the tail pipe from the muffler.

### Installation Procedure

The installation procedure is the reverse of the removal procedure.

## CATALYTIC MUFFLER MAINTENANCE

Replace the muffler ASSY every year (2000 hours) on either the gasoline or diesel engine vehicle.



**<https://www.ebooklibonline.com>**

Hello dear friend!

Thank you very much for reading.

Enter the link into your browser.

The full manual is available for immediate download.

**<https://www.ebooklibonline.com>**