

FOREWORD

This manual covers the service procedures of the TOYOTA FORKLIFT 5FGC70~15 Series. Please use this manual for providing quick, correct servicing of the corresponding forklift models.

*This manual deals with the above models as of September **7988**. Please understand that disagreement can take place between the descriptions in the manual and actual vehicles due to change in design and specifications. Any change or modifications thereafter will be informed by Toyota *Industrial Vehicles*' Parts & Service News.*

For the service procedures of the mounted engine, read the repair manuals listed below as reference together with this manual.

(Reference)

Repair manuals related to this manual are as follows:

TOYOTA INDUSTRIAL VEHICLE 4Y ENGINE

REPAIR MANUAL (No. CE602)

TOYOTA INDUSTRIAL VEHICLE 4P ENGINE

REPAIR MANUAL (No. CE604)

TOYOTA MOTOR CORPORATION

SECTION INDEX

GROUP INDEX	SECTION
GENERAL	0
ENGINE	1
TORQUE CONVERTER	2
DIFFERENTIAL	3
FRONT AXLE	4
REAR AXLE	5
STEERING	6
BRAKE	7
BODY	8
MATERIAL HANDLING SYSTEM	9
MAST	10
CYLINDER	11
OIL PUMP	12
OIL CONTROL VALVE	13
APPENDIX	14

GENERAL

0

	Page
EXTERIOR VIEWS	0-2
VEHICLE LISTING	0-3
FRAME NUMBER	0-3
ABBREVIATIONS	0-4
OPERATIONAL TIPS	0-4
STANDARD BOLT & NUT TIGHTENING TORQUE	0-5
HIGH PRESSURE HOSE FITTING TIGHTENING TORQUE	0-7
WIRE ROPE SUSPENSION ANGLE LIST	0-8
SAFE LOAD FOR EACH WIRE ROPE SUSPENSION ANGLE	0-8
COMPONENT WEIGHT	0-9
RECOMMENDED LUBRICANT QUANTITY & TYPE	0-10
LUBRICATION CHARTS	0-11
PERIODIC MAINTENANCE	0-12
PERIODIC REPLACEMENT LUBRICANTS AND PARTS	0-18

<https://www.ebooklibonline.com>

Hello dear friend!

Thank you very much for reading.

Enter the link into your browser.

The full manual is available for immediate download.

<https://www.ebooklibonline.com>

EXTERIOR VIEWS



Front View

LAR32-36



Rear View

LAR32-38

VEHICLE LISTING

Payload	Model	Engine model	Engine type	Drive system	Remarks
1.0 ton	5FGC10	4Y	Gasoline	Torque converter	P/S installed as standard
	30-5FGC10	4P	†	†	†
1.25 ton	5FGC13	4Y	†	†	†
	30-5FGC13	4P	†	t	t
1.5 ton	5FGC15	4Y	t	†	†
	30-5FGC15	4P	t	t	†

FRAME NUMBER

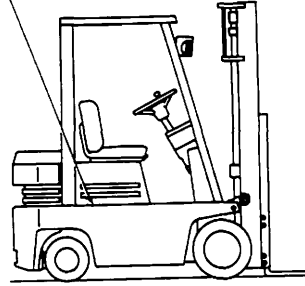
Engine	Vehicle model	Punching	Punching position
4Y	5FGC10	5FGC15-10011	<p>Frame No. punching position</p> 
	5FGC13		
	5FGC15		
4P	30-5FGC10	305FGC15-10011	
	30-5FGC13		
	30-5FGC15		

ABBREVIATIONS

Abbreviations used in this manual are as follows:

Abbreviation (Code)	Meaning	Abbreviation (Code)	Meaning
ABDC	After Bottom Dead Center	P/S	Power Steering
ASSY	Assembly	RH	Right Hand
ATDC	After Top Dead Center	SAE	Society of Automotive Engineers (USA)
ATM	Automatic Transmission	SST	Special Service Tool
BBDC	Before Bottom Dead Center	STD	Standard
LH	Left Hand	SUB-ASSY	Sub-assembly
LLC	Long Life Coolant	T =	Tightening Torque
MTM	Manual Transmission	OOT	Number of Teeth (00)
OHV	Overhead valve	U/S	Undersize
OPT	Option	w/	With
O/S	Oversize		
PS	Horsepower		

OPERATIONAL TIPS

1. Safe operation
 - (1) Make sure that correct size wire is used for hoisting a heavy material.
 - (2) After jacking up, always support with rigid racks or stands.
2. Preparation of SSTs and measuring tools
 - (1) Prepare SSTs and measuring tools before starting operation.
3. Clearing and arrangement
 - (1) Always keep the workshop neat and orderly for easy operation.
 - (2) Disassembly of hydraulic equipment shall always be done in a clean place using clean tools.
4. Genuine Toyota parts

Genuine Toyota parts should be used even in the replacement of packings, gaskets and O-rings.
5. Repairs on electrical system

Before doing any repairs on the electrical system, disconnect the cables from the battery terminals. Be sure to disconnect the negative (-) cable first.
6. Tightening torque for installation

Be sure to observe the tightening torque given in this manual. If not specified, tighten to the torque listed in standard bolt & nut tightening torque.
7. Defect status grasp

Do not start disassembly and replacement as soon as a defect is found, but first grasp whether the defect requires disassembly and replacement. In the case of torque converter for example, do not attempt torque converter disassembly upon a failure in starting the vehicle, but first check such factors as the oil, pressure and rotation status causing the failure.

STANDARD BOLT & NUT TIGHTENING TORQUE

Standard bolt and nut tightening torques are not indicated.





Judge the standard tightening torque as shown below.

1. Find out the straight type of bolt from the list below and then find the bolt tightening torque from the table.
2. The nut tightening torque can be judged from the mating bolt type.

BOLT STRENGTH TYPE IDENTIFICATION METHOD

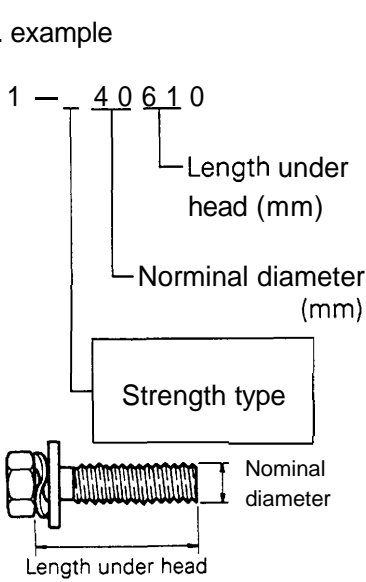
1. Identification by bolt shape

2. Identification by part No.

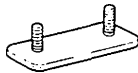
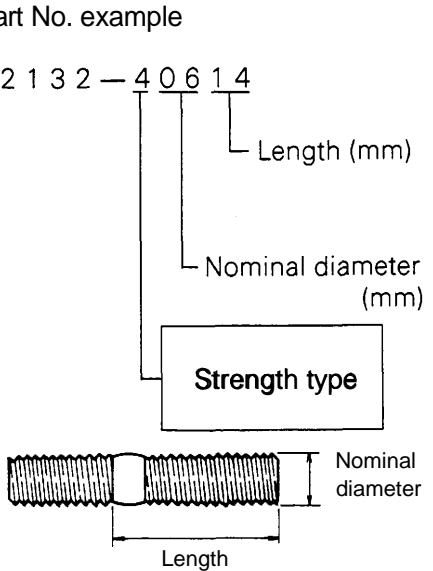
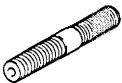
	Shape and identification method		Strength type	Hexagon bolt	
Standard hexagon bolt		Number in relief or hallmark on the head	4 = 4T 5 = 5T 6 = 6T 7 = 7T	Part No. example 9 1 1 1 1 — 4 0 6 1 0 	
		No mark	4T		
Flanged hexagon bolt		No mark	4T		
Standard hexagon bolt		Standard bolt with two relief lines on the head	5T		
Flanged hexagon bolt		Standard bolt with two relief lines on the head	6T		
Standard hexagon bolt		Standard bolt with three relief lines on the head	7T		
Weld bolt			4T		
Stud bolt		No mark	6T		Stud bolt Part No. example 9 2 1 3 2 — 4 0 6 1 4 
		Approximately 2 mm (0.08 in.) hollow on either both ends			

BAHS28

BAHS25

TIGHTENING TORQUE TABLE

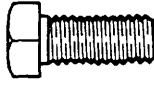
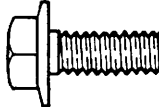
Strength type	Nominal diameter mm	Pitch mm	Standard tightening torque kg-cm (ft-lb)	
			Standard 	Flanged 
4T	6	1.0	55 (4.0)	60 (4.3)
	8	1.25	130 (9.4)	145 (10.5)
	10	1.25	260 (18.8)	290 (20.9)
	12	1.25	480 (34.7)	540 (39.0)
	14	1.5	760 (54.9)	850 (61.4)
	16	1.5	1150 (83.0)	—
5T	6	1.0	65 (4.7)	—
	8	1.25	160 (11.6)	—
	10	1.25	330 (23.8)	—
	12	1.25	600 (43.3)	—
	14	1.5	930 (67.1)	—
	16	1.5	1400 (101.1)	—
6T	6	1.0	80 (5.8)	90 (6.5)
	8	1.25	195 (14.1)	210 (15.2)
	10	1.25	400 (28.9)	440 (31.8)
	12	1.25	730 (52.7)	810 (58.5)
	14	1.5	1100 (79.4)	1250 (90.3)
7T	6	1.0	110 (7.9)	120 (8.7)
	8	1.25	260 (18.8)	290 (20.9)
	10	1.25	530 (38.3)	590 (42.6)
	12	1.25	970 (70.0)	1050 (75.8)
	14	1.5	1500 (108.3)	1700 (122.7)
	16	1.5	2300 (166.1)	—

PRECOAT BOLTS

(Bolts with seal lock agent coating on threads)

1. Do not use the precoat bolt as it is in either of the following cases:
 - (a) After it is removed.
 - (b) When the precoat bolt is moved (loosened or tightened) by tightness check, etc.

Note:

For torque check, use the lower limit of the allowable tightening torque range. If the bolt moves, retighten it according to the steps below.

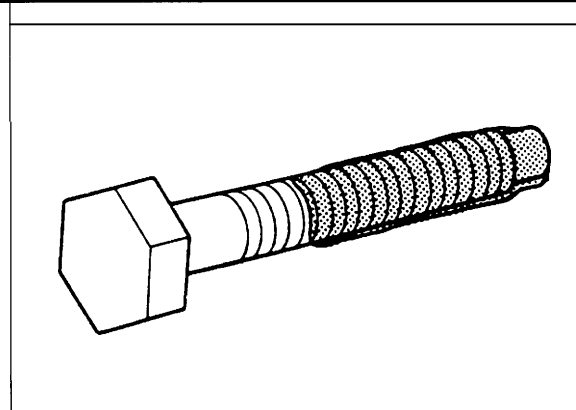

Precoat Bolts

B4460

2. Method for reuse of precoat bolts
 - (1) Wash the bolt and threaded hole. (The threaded hole must be washed even for replacement of the bolt.)
 - (2) Perfectly dry the washed parts by air blowing.
 - (3) Coat the specified seal lock agent to the threaded portion of the bolt.

HIGH PRESSURE HOSE FITTING TIGHTENING TORQUE

1. When connecting a high pressure hose, wipe the hose fitting and mating nipple contact surfaces with clean cloth to remove foreign matters and dirt. Also check for no dent or other damage on the contact surfaces before installation.
2. When connecting a high pressure hose, hold the hose to align the fitting with the nipple and tighten the fitting.
3. The maximum tightening torque must not exceed twice the standard tightening torque.

Nominal diameter of screw	Standard tightening torque kg-m (ft-lb)		Hose inside diameter (mm)
	Standard	Tightening range	
7/16 — 20UNF	2.5 (18.1)	2.4— 2.6 (17.4— 18.8)	6
9/16 — 18UNF	5.0 (36.2)	4.8— 5.3 (34.7— 38.3)	9
3/4 — 16UNF	6.0 (43.4)	5.7— 6.3 (41.2— 45.5)	12
7/8 — 14UNF	6.0 (43.4)	5.7~ 6.3 (41.2— 45.5)	12
1 1/16 — 12UNF	12.0 (86.8)	11.4—12.6 (82.4— 91.1)	19
1 5/16 — 12UNF	14.0 (101.2)	13.3—14.7 (96.2—106.3)	25
PF1/4	5.0 (36.2)	4.8— 5.3 (34.7— 38.3)	9
PF3/8	5.0 (36.2)	4.8— 5.3 (34.7— 38.3)	9
PF1/2	6.0 (43.4)	5.7— 6.3 (41.2— 45.5)	12
PF3/4	12.0 (86.8)	11.4~12.6 (82.4— 91.1)	19
PF1	14.0 (101.2)	13.3—14.7 (96.2—106.3)	25

WIRE ROPE SUSPENSION ANGLE LIST

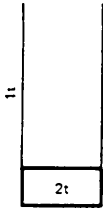
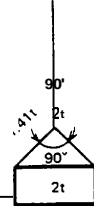
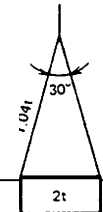
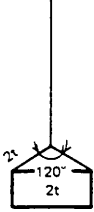
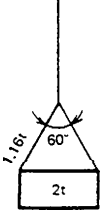
Lifting angle	Tension	Compression	Suspension method	Lifting angle	Tension	Compression	Suspension method
0°	1.00 time	0 time		90°	1.41 time	1.00 time	
30°	1.04 time	0.27 time		120°	2.00 time	1.73 time	
60°	1.16 time	0.58 time					

SAFE LOAD FOR EACH WIRE ROPE SUSPENSION ANGLE

Unit: ton (lb)

Rope diameter	Cutting load	Single-rope suspension	Two-rope suspension				For-rope suspension			
		0°	0°	30°	60°	90°	0°	30°	60°	90°
6 mm (0.24 in.)	2.18 (4807)	0.31 (683.6)	0.62 (1367)	0.6 (1323)	0.53 (1169)	0.44 (970)	1.24 (2734)	1.2 (2646)	1.06 (2337)	0.88 (1940)
8 mm (0.32 in.)	3.21 (7078)	0.45 (992.3)	0.9 (1985)	0.87 (1918)	0.78 (1720)	0.64 (1411)	1.8 (3969)	1.74 (3937)	1.56 (3440)	1.28 (2822)
10 mm (0.4 in.)	5.02 (11069)	0.71 (1565.6)	1.43 (3153)	1.37 (3021)	1.2 (2646)	1.0 (2205)	2.8 (6174)	2.7 (5954)	2.4 (5292)	2.0 (4410)
12.5 mm (0.5 in.)	7.84 (17387)	1.12 (2469.5)	2.2 (4851)	2.1 (4631)	1.9 (4190)	1.5 (3308)	4.4 (9702)	4.2 (9261)	3.8 (8379)	3.0 (6615)
14 mm (0.56 in.)	9.83 (21675)	1.4 (3087)	2.8 (6174)	2.7 (5954)	2.4 (5292)	1.9 (4190)	5.6 (12348)	5.4 (11907)	4.8 (10584)	3.8 (8379)

COMPONENTS WEIGHT

Engine	4Y engine: 134 kg (294.8 lbs) 4P engine: 128 kg (281.6lbs)
Torque converter	Okamura torque converter: 120 kg (264 lbs)
Differential & front axle (w/brake)	210 kg (462 lbs)
Counterweight	1.0 ton: 495 kg (1100 lbs) 1.25 ton: 695 kg (1550 lbs) 1.50 ton: 895 kg (2000 lbs)
V Mast (max. fork height: 3000 mm)	W/Lift bracket: 414 kg (910 lbs) L/Lift bracket: 322 kg (708lbs)

RECOMMENDED LUBRICANT QUANTITY & TYPES

Description	Classification	Type	Application	Capacity
Gasoline	API SD, SE, SF	Motor oil	4P	4.3 ℓ (1.14 US gal)
		SAE30 (SAE20 in cold area) SAE20W-40 (SAE 10W-30 in cold area)	4Y	4.0 ℓ (1.06 US gal)
Torque converter	ATF	GM Dexron® II	OKAMURA make	9.5 ℓ (2.51 US gal)
Differential	API GL-4 GL-5	Hypoid gear oil SAE85W-90		5.0 ℓ (1.32 US gal)
Hydraulic oil	ISO VG32	Hydraulic oil #90		All capacity 24 ℓ (6.34 US gal) Oil tank capacity 19 ℓ (5.0 US gal)
Brake	—	SAE J-1703 DOT-3		Proper quantity Reservoir Tank 0.2 ℓ (0.05 US gal)
Chassis parts		MP Grease	All models	Proper quantity
Coolant	LLC	●*LLC 30-50% mixture (for winter or all-season) @Coolant with rust-inhibitor (for spring, summer and autumn)	11.5 ℓ (3.04 US gal)	
Coolant (Reservoir Tank)	t	t	All models	0.6 ℓ (0.16 US gal)

LUBRICATION CHARTS

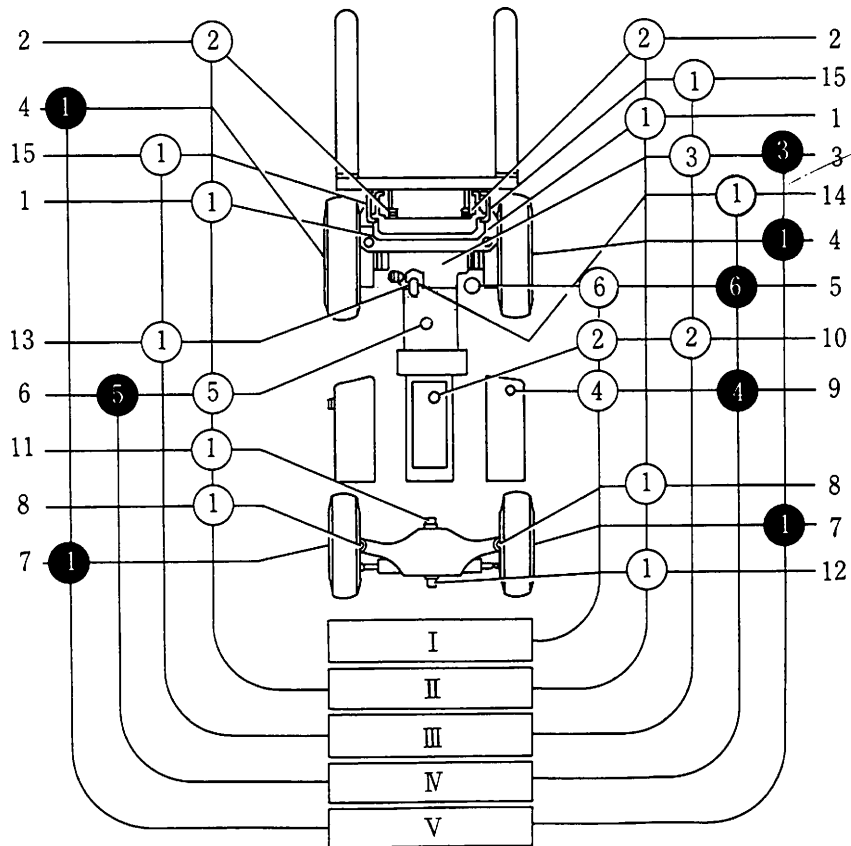

- | | |
|--|--|
| <ul style="list-style-type: none"> 1. Mast support bushing 2. Chain 3. Differential 4. Front wheel bearing 5. Brake master cylinder 6. Torque converter mission 7. Rear wheel bearing 8. Steering knuckle king pin 9. Oil tank 10. Engine crank case 11. Rear axle beam front 12. Rear axle beam rear 13. Tilt steering universal joint 14. Tilt steering locking mechanism 15. Tilt cylinder front pin | <ul style="list-style-type: none"> I Inspect every 8 hours (daily) II Inspect every 40 hours (weekly) III Inspect every 170 hours (monthly) IV Inspect every 1000 hours (6 monthly) V Inspect every 2000 hours (annually) ○ Inspect and service ● Replace |
|--|--|
-
- | |
|--|
| <ul style="list-style-type: none"> 1. MP grease 2. Engine oil 3. Hypoid gear oil 4. Hydraulic oil 5. Automatic transmission fluid 6. Brake fluid |
|--|

Lubrication Chart

LARM81

PERIODIC MAINTENANCE

INSPECTION METHOD

I : Inspection. Repair or replacement if required.

M : Measurement. Repair or adjustment if required.

T : Retightening C : Cleaning L : Lubrication

* : For new vehicle *1 : Soapy water *2 : Detector *3 : Flaw detector

Item		Inspection Period				
		Months	1	3	6	12
		Hours	170	500	1000	2000
ENGINE						
Main body	Proper starting and abnormal noise	I	O	O	O	O
	Rotating condition at idling	M	O	O	O	O
	Rotating condition during acceleration	M	O	O	O	O
	Exhaust gas condition	I	O	O	O	O
	Air cleaner element	C	O	O	O	O
	Valve clearance	M	O*			O
	Compression	M				O
	Cylinder head bolt loosening	T	O*			O
	Muffler rubber mount	I				O
PCV system	Clogging and damage in PCV valve and piping	I	O	O	O	O
Governor	No-load maximum rpm	M	O	O	O	O
Lubrication system	Oil leak	I	O	O	O	O
	Oil level	I	O	O	O	O
	Clogging and dirt of oil filter	I	O	O	O	O
Fuel system	Fuel leak	I	O	O	O	O
	Operation of carburetor link mechanism	I	O	O	O	O
	Dirt and clogging of fuel filter and element	I	O	O	O	O
Cooling system	Coolant level in radiator and leak	I	O	O	O	O
	Rubber hose degradation	I	O	O	O	O
	Radiator cap condition	I	O	O	O	O
	Fan belt tension, looseness and damage	I	O	O	O	O
	Radiator rubber mount	I				O

Item		Inspection Period				
		Months	1	3	6	12
		Hours	170	500	1000	2000
POWER TRANSMISSION SYSTEM						
Differential	Leak	I	O	O	O	O
	Oil level	I	O	O	O	O
	Bolt loosening	T				O
Torque converter and transmission	Leak	I	O	O	O	O
	Fluid level	I	O	O	O	O
	Operating mechanism function and looseness	I	O	O	O	O
	Control valve and clutch functions	I	O	O	O	O
	Inching valve function	I	O	O	O	O
	Stall and hydraulic pressure measurement	M			O	O
DRIVE SYSTEM						
Wheels	Tire cuts, damage and uneven wearing	I	O	O	O	O
	Loose hub nuts	T	O	O	O	O
	tire groove depth	M	O	O	O	O
	metal chips, pebbles and other foreign matter trapped in tire grooves	I	O	O	O	O
	Rim, side bearing and disc wheel damage	I	O	O	O	O
	Abnormal sound and looseness of front wheel bearing	I	O	O	O	O
	Abnormal sound and looseness of rear wheel bearing	I	O	O	O	O
Front axle	Cracks, damage and deformation of housing	I				O
Rear axle	Cracks, damage and deformation of beam	I				O
	Looseness of axle beam in vehicle longitudinal direction	M	O*			O
STEERING SYSTEM						
Steering wheel	Play and looseness	I	O	O	O	O
	Function	I	O	O	O	O
Gear box	Oil leak	I	O	O	O	O
	Looseness of mounting	T	O	O	O	O
Power steering	Oil leak	I	O	O	O	O
	Mounting and linkage looseness	I	O	O	O	O
	Damage of power steering hose	I				O

Item		Inspection Period				
		Months	1	3	6	12
		Hours	170	500	1000	2000
Knuckle	King pin looseness	I	○	○	○	○
	Cracks and deformation	I				○
Steering wheel	Wheel alignment	M				○
	Left and right turning angle	M				○
BRAKING SYSTEM						
Brake pedal	Play and reserve	M	○	○	○	○
	Braking effect	I	○	○	○	○
Parking brake	Operating force	I	○	○	○	○
	Braking effect	I	○	○	○	○
	Rod and cable looseness and damage	I	○	○	○	○
Brake pipe	Leak, damage and mounting condition	I	○	○	○	○
Reservoir tank	Leak and fluid level	I	○	○	○	○
Master cylinder and wheel cylinder	Function, wear, damage, leak and mounting looseness	I				○
Brake drum and brake shoe	Clearance between drum and lining	M	○	○	○	○
	Wear of shoe sliding portion and lining	I				○
	Drum wear and damage	I				○
	Shoe operating condition	I				○
	Anchor pin rusting	I				○
	Return spring fatigue	M				○
	Automatic adjuster function	I				○
Backing plate	Deformation, cracks and damage	I				○
	Loose mounting	T				○
MATERIAL HANDLING SYSTEM						
Forks	Abnormality of fork and stopper pin	I	○	○	○	○
	Misalignment between left and right fork fingers	I	○	○	○	○
	Cracks at fork root and welded part	I*3				○
Mast and fork bracket	Deformation and damage of each part and crack at welded part	I	○	○	○	○
	Mast and lift bracket looseness	I	○	○	○	○
	Wear and damage of mast support bush	I				○
	Wear, damage and rotating condition of rollers	I	○	○	○	○

Item		Inspection Period				
		Months	1	3	6	12
		Hours	170	500	1000	2000
Mast and fork bracket	Wear and damage of roller pins	I				0
	Wear and damage of mast strip	I	0	0	0	0
Chain and chain wheel	Tension, deformation and damage of chain	I	0	0	0	0
	Chain lubrication	I	0	0	0	0
	Abnormality of chain anchor bolt	I	0	0	0	0
	Wear, damage and rotating condition of chain wheel	I	0	0	0	0
Various attachments	Abnormality and mounting condition of each part	I	0	0	0	0
HYDRAULIC SYSTEM						
Cylinder	Loosening and damage of cylinder mounting	I	0	0	0	0
	Deformation and damage of rod, rod screw and rod end	I	0	0	0	0
	Cylinder operation	I	0	0	0	0
	Natural drop and natural forward tilt (hydraulic drift)	M	0	0	0	0
	Oil leak and damage of cylinder mounting	I	0	0	0	0
	Wear and damage of pin and cylinder bearing	I	0	0	0	0
	Lifting speed	M	0	0	0	0
	Uneven movement	I	0	0	0	0
Oil pump	Oil leak and abnormal sound	I	0	0	0	0
Hydraulic oil tank	Oil level and contamination	I	0	0	0	0
	Tank and oil strainer	C			0	0
	Oil leak	I	0	0	0	0
Control lever	Loose linkage	I	0	0	0	0
	Operation	I	0	0	0	0
Oil control valve	Oil leak	I	0	0	0	0
	Relief pressure measurement	M				0
	Relief valve and tilt lock valve functions	I	0	0	0	0
Hydraulic piping	Oil leak	I	0	0	0	0
	Deformation and damage	I	0	0	0	0
	Loose joint	T	0	0	0	0

Item		Inspection Period				
		Months	1	3	6	12
		Hours	170	500	1000	2000
ELECTRICAL SYSTEM						
Ignition timing	Cracks on distributor cap	I	O	O	O	O
	Spark plug burning and gap	I	O	O	O	O
	Distributor side terminal burning	I	O	O	O	O
	Distributor cap center piece wear and damage	I	O	O	O	O
	Plug cord internal discontinuity	I				O
	Ignition timing	M			O	O
Starting motor	Pinion gear meshing status	I	O	O	O	O
Charger	Charging function	I	O	O	O	O
Battery	Battery fluid level	I	O	O	O	O
	Battery fluid specific gravity	M			O	O
Electrical wiring	Damage of wiring harness	I	O	O	O	O
	Fuses	I	O	O	O	O
SAFETY DEVICES, ETC.						
Head guard	Cracks at welded portion	I	O	O	O	O
	Deformation and damage	I	O	O	O	O
Back-rest	Loosening of mounting	T	O	O	O	O
	Deformation, crack and damage	I	O	O	O	O
Lighting system	Function and mounting condition	I	O	O	O	O
Horn	Function and mounting condition	I	O	O	O	O
Direction indicator	Function and mounting condition	I	O	O	O	O
Instruments	Functions	I	O	O	O	O
Backup buzzer	Function and mounting condition	I	O	O	O	O
Rear-view mirror	Dirt. damage	I	O	O	O	O
	Rear reflection status	I	O	O	O	O
Seat	Loosening and damage of mounting	I	O	O	O	O

Item		Inspection Period				
		Months	1	3	6	12
		Hours	170	500	1000	2000
Body	Damage and cracks of frame, cross members, etc.	I				O
	Bolt looseness	T				O
Others	Grease up	L	O	O	O	O

PERIODIC REPLACEMENT LUBRICANTS AND PARTS

● : Replacement

Interval	1 month	3 months	6 months	12 months
	170 hours	500 hours	1000 hours	2000 hours
Engine	●	●	●	●
Engine oil filter		●	●	●
Engine coolant (every 2 years for LLC)		●	●	●
Fuel filter			●	●
Torque converter oil			●	●
Torque converter oil filter				●
Differential oil				●
Hydraulic oil			●	●
Hydraulic oil filter	●*1		●	●
Wheel bearing grease				●
Spark plugs			●	●
Cyclone air cleaner element				●
Brake master cylinder rubber parts				●
Cups and seals for master and wheel cylinders				●
Brake fluid			●	●
Power steering hoses				●*2
Power steering rubbers parts				●*2
Hydraulic hoses				●*2
Reservoir tank tube				●*2
Fuel hoses				●*2
Torque converter rubber hoses				●*2
Chains				●*3

*1 : for new vehicle *2 : Every 2 years *3 : Every 3 years

Replacement shall be made upon arrival of the operation hours or months, whichever is earlier.

ENGINE

	Page
GENERAL	1-2
ENGINE PERFORMANCE CURVES	
ENGINE ASSEMBLY REMOVAL & INSTALLATION	1-6
ENGINE TUNE-UP	1-9
AIR CLEANER	1-11
SPECIFICATIONS	1-11
COMPONENTS	1-12
INSPECTION	1-13
RADIATOR	1-15
GENERAL	1-15
COMPONENTS	1-15
REMOVAL	1-16
INSPECTION	1-17
INSTALLATION	1-18
MUFFLER & EXHAUST PIPE	1-19
GENERAL	1-19
COMPONENTS	1-19
REMOVAL	1-20
INSPECTION	1-21
INSTALLATION	1-21
BATTERY	1-22
COMPONENTS	1-22
SPECIFICATIONS	1-22
INSPECTION	1-23
REMOVAL	1-23
INSTALLATION	1-23
STARTING MOTOR	1-24
REMOVAL	1-24
INSTALLATION	1-24
ALTERNATOR	1-25
REMOVAL	1-25
INSTALLATION	1-26
ACCELERATOR PEDAL	1-27
ADJUSTMENT	1-27
COMPONENTS	1-28



Suggest:

For more complete manuals. Please go to the home page.

<https://www.ebooklibonline.com>

If the above button click is invalid. Please download this document first, and then click the above link to download the complete manual.

Thank you so much for reading

GENERAL

Engine performances	
Piston displacement (cc)	2237
No-load static maximum speed (rpm)	2450 ± 50
Rated output (PS/rpm)	45/2100
Maximum torque (kg-m/rpm)	16.5/1800

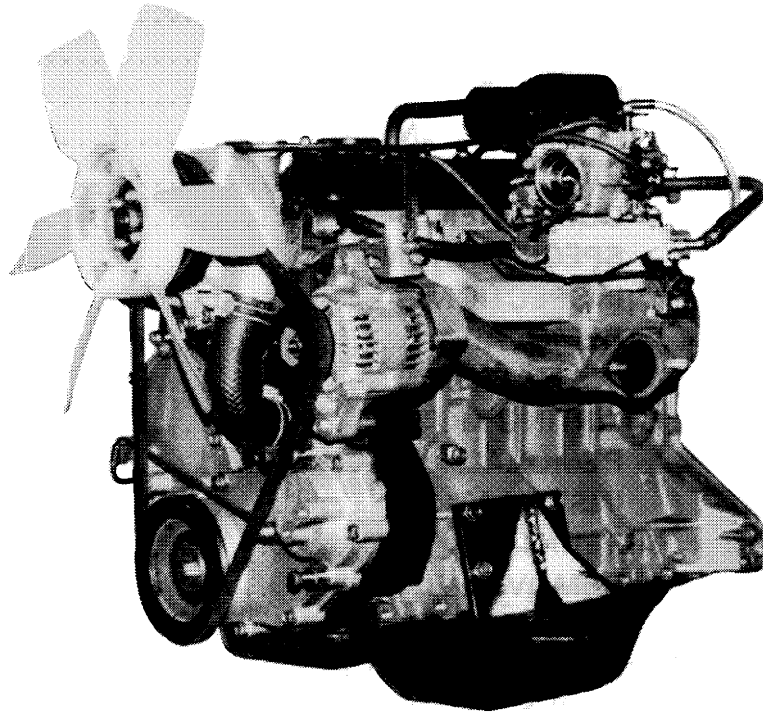
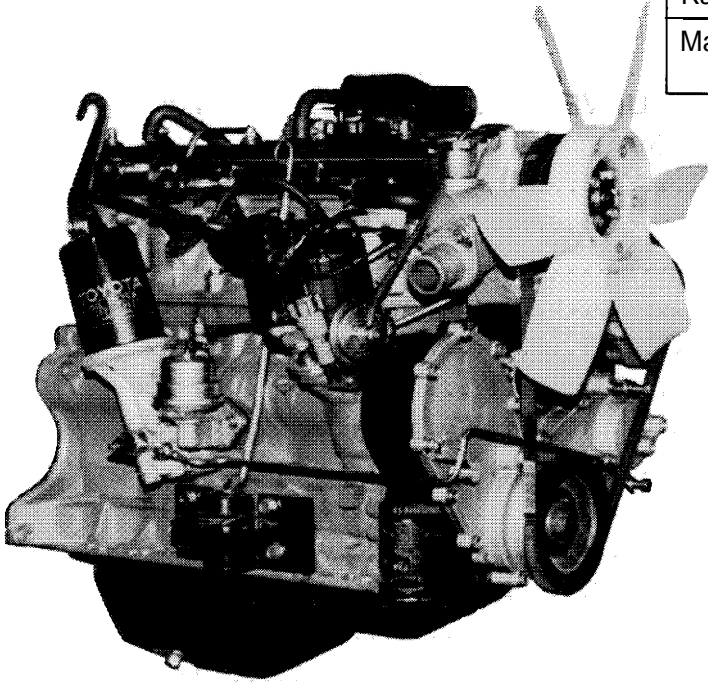

4Y Engine Exterior View

KAJ14-2.6

Engine performances	
Piston displacement (cc)	1493
No-load static maximum speed (rpm)	2900 ± 50
Rated output (PS/rpm)	33/2650
Maximum torque (kg-m/rpm)	10.5/1800

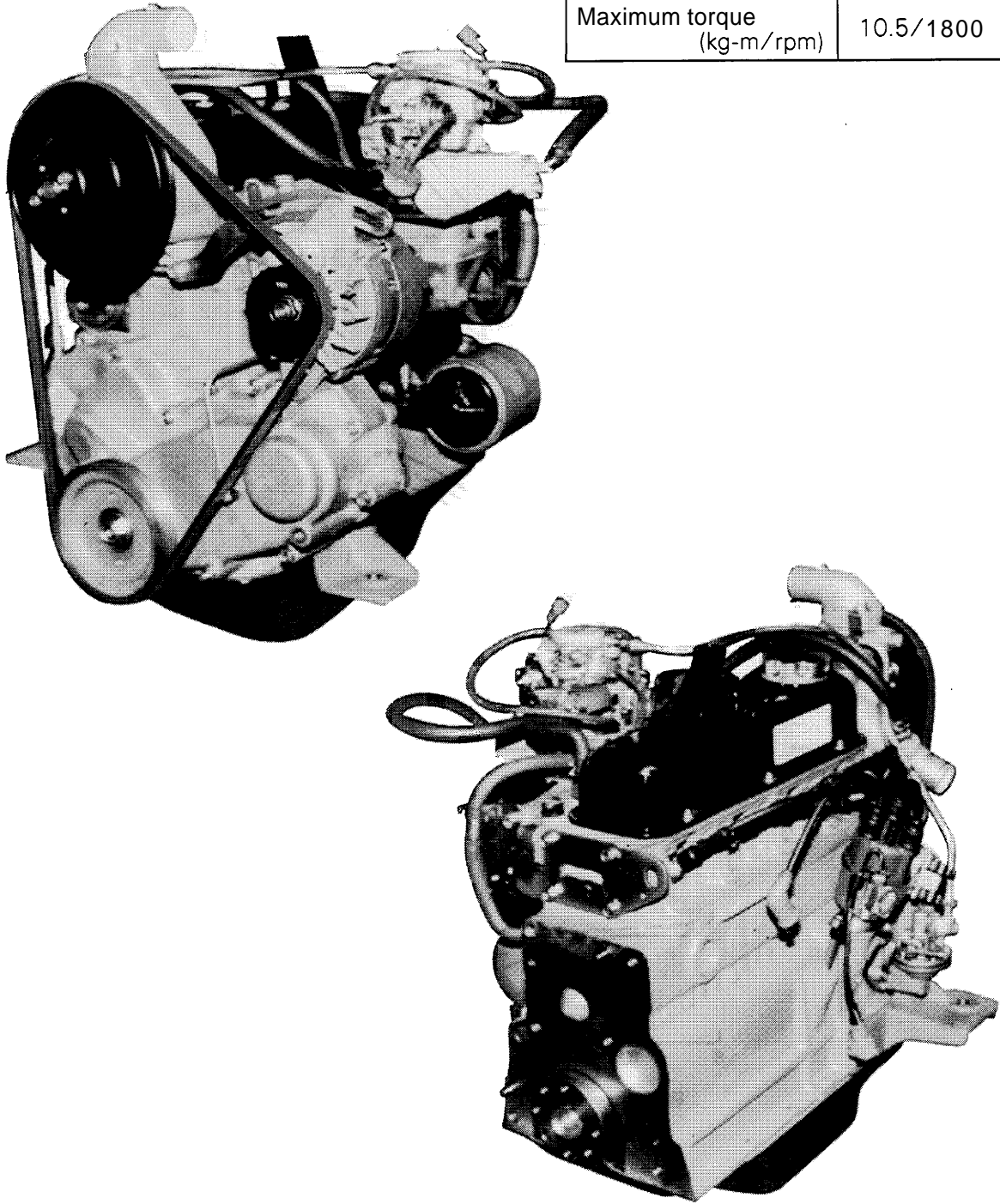

4P Engine Exterior View

KAF1-1.6

<https://www.ebooklibonline.com>

Hello dear friend!

Thank you very much for reading.

Enter the link into your browser.

The full manual is available for immediate download.

<https://www.ebooklibonline.com>