

5FBC13-30

RETURN TO: MAIN INDEX

RETURN TO: SERVICE MANUAL INDEX

GENERAL

BATTERY

CONTROL CIRCUIT

MULTIDISPLAY FUNCTIONS

ELECTRICAL SYSTEM TROUBLESHOOTING

MOTOR

DRIVE UNIT

FRONT AXLE

REAR AXLE

STEERING

BRAKE

BODY AND FRAME

MATERIAL HANDLING SYSTEM

MAST

CYLINDER

OIL PUMP

OIL CONTROL VALVE

APPENDIX

FOREWORD

This manual covers the service procedures of the TOYOTA BATTERY FORKLIFT 5FBC13 - 30 Series. Please use this manual for providing quick, correct servicing of the corresponding forklift models.

This manual deals with the above models as of November 1991. Please understand that disagreement can take place between the descriptions in the manual and actual vehicles due to change in design and specifications. Any change or modifications thereafter will be informed by Toyota Industrial Vehicles' Parts & Service News.

TOYOTA MOTOR CORPORATION

SECTION INDEX

NAME	SECTION
GENERAL	0
BATTERY	1
CONTROL CIRCUIT	2
MULTIDISPLAY FUNCTIONS	3
ELECTRICAL SYSTEM TROUBLESHOOTING	4
DRIVE UNIT	•
FRONT AXLE	7
REAR AXLE	8
STEERING	9
BRAKE	0
BODY & FRAME	11
MATERIAL HANDLING SYSTEM	12
MAST	13
CYLINDER	14
OIL PUMP	15
OIL CONTROL VALVE	16
APPENDIX	17

<https://www.ebooklibonline.com>

Hello dear friend!

Thank you very much for reading.

Enter the link into your browser.

The full manual is available for immediate download.

<https://www.ebooklibonline.com>

GENERAL

	Page
EXTERIOR VIEWS	0-2
VEHICLE MODEL	0-3
FRAME NUMBER	0-4
HOW TO READ THIS MANUAL	0-5
EXPLANATION METHOD	0-5
TERMINOLOGY	0-6
ABBREVIATIONS	0-6
LIST OF ABBREVIATIONS AND SYMBOLS	0-7
OPERATIONAL TIPS	0-8
CIRCUIT TESTER	0-9
STANDARD BOLT & NUT TIGHTENING TORQUE	0-11
BOLT STRENGTH TYPE IDENTIFICATION METHOD	0-11
TIGHTENING TORQUE TABLE	0-12
PRECOAT BOLTS	0-13
HIGH PRESSURE HOSE FITTING TIGHTENING TORQUE	0-13
WIRE ROPE SUSPENSION ANGLE LIST	0-14
SAFE LOAD FOR EACH WIRE ROPE SUSPENSION ANGLE	0-14
COMPONENTS WEIGHT	0-15
RECOMMENDED LUBRICANTS AND CAPACITIES	0-16
LUBRICATION CHART	0-17
PERIODIC MAINTENANCE	0-18
PERIODIC REPLACEMENT OF PARTS AND LUBRICANTS	0-23

EXTERIOR VIEWS

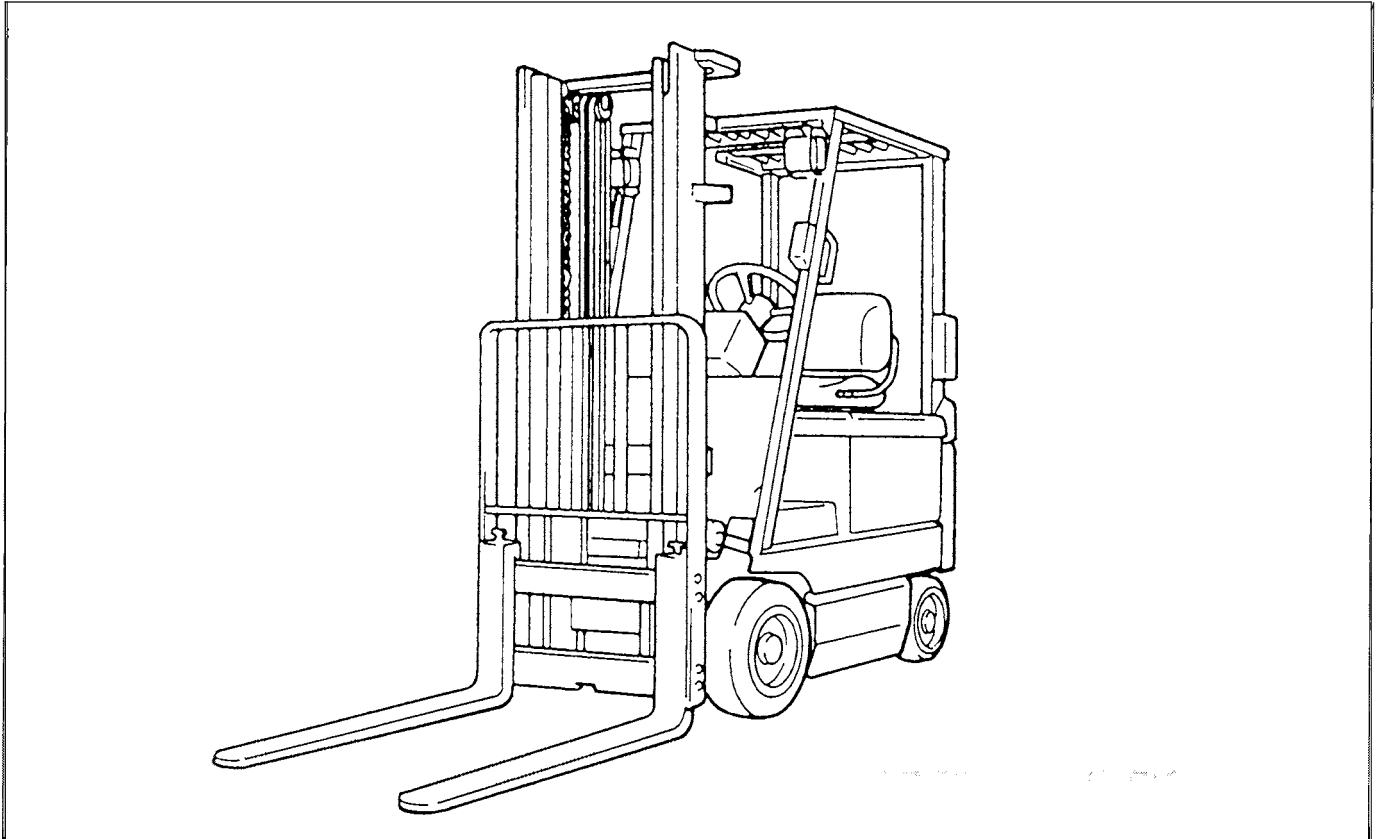

Front View

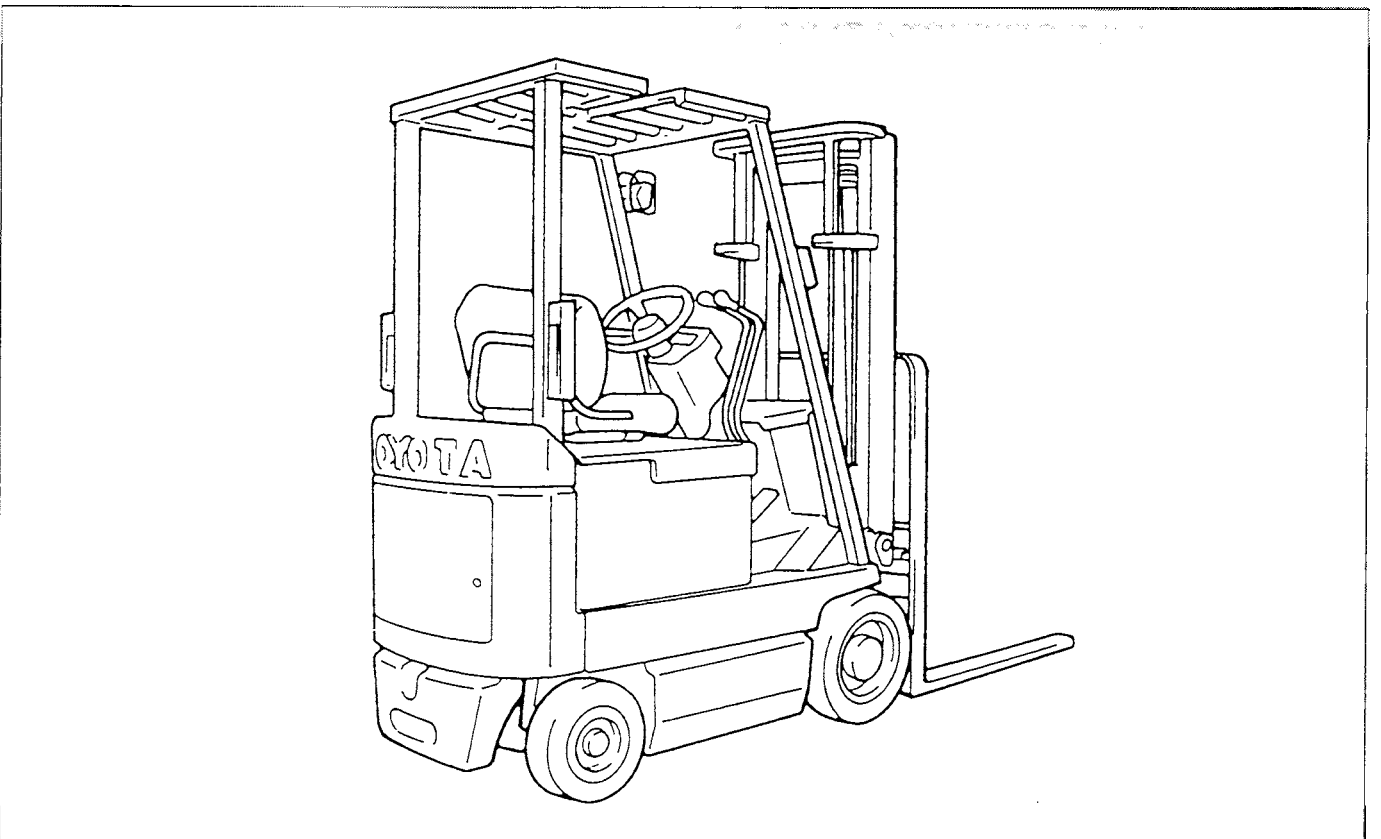

Rear View

VEHICLE MODEL

		Model		Voltage V	Control Circuit	
I ton series	1.25 ton	5FBC13	Standard	36 or 48	MCS-III	
		30-5FBC13	Dustproof	↑	↑	
	1.5 ton	5FBC15	Standard	↑	↑	
		30-5FBC15	Dustproof	↑	↑	
2 ton series	1.75 ton	5FBC18	Standard	↑	↑	
		30-5FBC18	Dustproof	↑	↑	
	2.0 ton	5FBC20	Standard	↑	↑	
		30-5FBC20	Dustproof	↑	↑	
		5FBCH20	Standard	↑	↑	
		30-5FBCH20	Dustproof	↑	↑	
	2.5 ton	5FBC25	Standard	↑	↑	
		30-5FBC25	Dustproof	↑	↑	
		5FBCH25	Standard	↑	↑	
		30-5FBCH25	Dustproof	↑	↑	
	3 ton series	2.75 ton	5FBC28	Standard	↑	↑
			30-5FBC28	Dustproof	↑	↑
3.0 ton		5FBC30	Standard	↑	↑	
		30-5FBC30	Dustproof	↑	↑	

FRAME NUMBER

Punching position

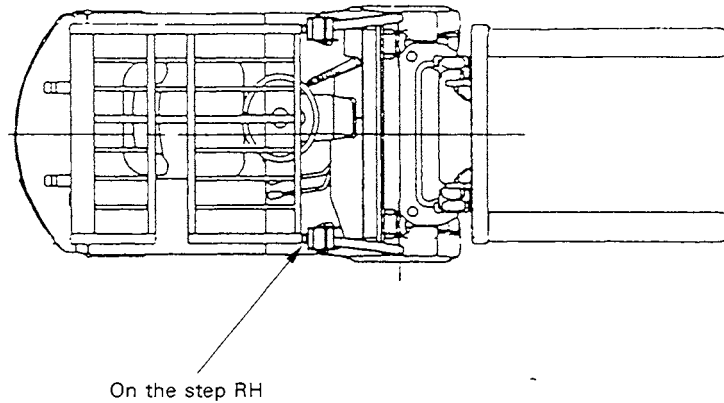

	Vehicle model	Punching format	
			EEC spec. (1992. 11 ~)
1 ton series	5FBC13	5FBC15-10011	5FBC15E10011
	5FBC15		
2 ton series	5FBC18	5FBC25-10011	5FBC25E10011
	5FBC20		
	5FBC25		
	5FBCH20	5FBCH25-10011	5FBCH25E10011
5FBCH25			
3 ton series	5FBC28	5FBC30-10011	5FBC30E10011
	5FBC30		
1 ton series	30-5FBC13	305FBC15-10011	305FBC15E10011
	30-5FBC15		
2 ton series	30-5FBC18	305FBC25-10011	305FBC25E10011
	30-5FBC20		
	30-5FBC25		
	30-5FBCH20	305FBCH25-10011	305FBCH25E10011
	30-5FBCH25		
3 ton series	30-5FBC28	305FBC30-10011	305FBC30E10011
	30-5FBC30		

HOW TO READ THIS MANUAL

EXPLANATION METHOD

1. Operation procedure

(1) The operation procedure is described in either pattern A or pattern B below.

Pattern A: Explanation of each operation step with a photo or illustration.

Pattern B: Explanation of operation procedure by indicating step numbers in one illustration, followed by explanation of cautions and notes summarized as point operations.

Example of description in pattern B

DISASSEMBLY·INSPECTION·REASSEMBLY

Tightening torque unit T = N·m (kg-cm)[ft-lb]

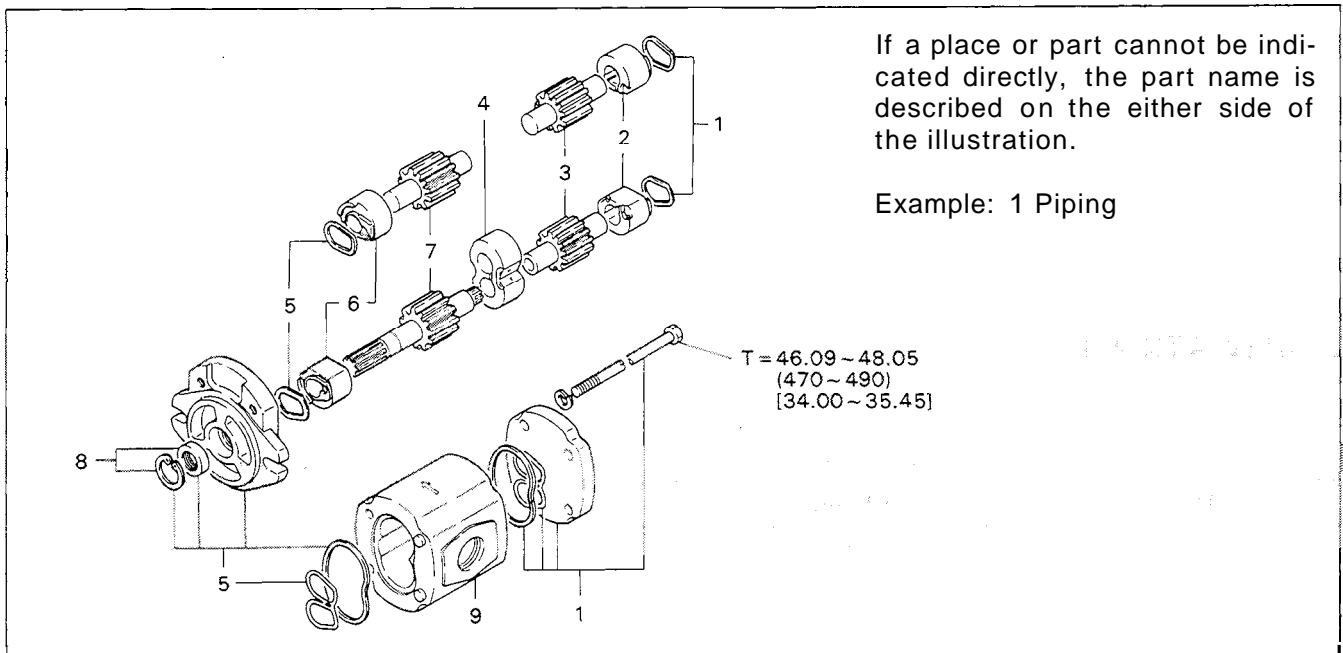

If a place or part cannot be indicated directly, the part name is described on the either side of the illustration.

Example: 1 Piping

Oil Pump Disassembly Procedure

Disassembly Procedure

- 1 Remove the cover. **[Point 1]**
- 2 Remove the bush **[Point 2]** ← Operation explained on a later page
- 3 Remove the gear.

Point operations Explanation of key point for operation with an illustration

[Point 1]

Disassembly: Put a match mark when removing the pump cover.

[Point 2]

Inspection: Measure the bush inside diameter.

Bush inside diameter limit: 19.12 mm (0.7528 in)

2. How to read components figures

- (1) The components figure use the illustration in the parts catalog for the vehicle model. Please refer to the catalog for checking the part name.
The number at the right shoulder of each components figure indicates the Fig. number in the parts catalog.

(Example)

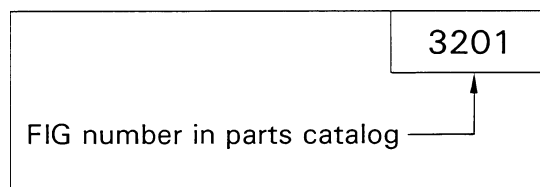

3. Matters omitted in this manual

- (1) This manual omits description of the following jobs, but perform them in actual operation:
 - ① Cleaning and washing of removed parts as required
 - ② visual inspection (Partially described)

TERMINOLOGY

Caution:

Important matters of which negligence may cause accidents. Be sure to observe them.

Note:

Important items of which negligence may cause accidents or matters in operation procedure requiring special attention.

Standard: Values showing allowable range in inspection and adjustment.

Limit: Maximum or minimum allowable value in inspection or adjustment.

ABBREVIATIONS

Abbreviation (code)	Meaning	Abbreviation (code)	Meaning
ASSY	Assembly	SST	Special service Tool
LH	Left hand	STD	Standard
OPT	Option	T =	Tightening torque
O/S	Oversize	○○T	Number of teeth (○○)
PS	Power steering	U/S	Undersize
RH	Right hand	W/	With
SAE	Society of Automotive Engineers (USA)		

LIST OF ABBREVIATIONS AND SYMBOLS

Symbol	Name	Symbol	Name	Symbol	Name
BATT	Battery	FR _Y	Flasher Relay	MS _{CH}	Charger Magnet Switch
B _Z	Buzzer	H	Horn	MW	Field Weakning Contactor
CAD/P	Drive/Pump Absorber Capacitor	L _{BU-L}	Back-up Lamp, LH	PB _{CPU}	Computer Print Board
CH	Charger	L _{BU-R}	Back-up Lamp, RH	PB _{SPS}	SPS Print Board
CHI	Forward Chime	L _{C-L}	Clearance Lamp, LH	R _L	Working Pilot Lamp
CHI _R	Reverse Chime	L _{F-L}	Clearance Lamp, RH	RF	Fan Resistor
CSD/P	Drive/Pump Current Sensor	L _{F-L}	Flasher Lamp, LH	RFW	Field Weakning Resistor
CS _{PS}	Power Steering Current Sensor	L _{F-LR}	Flasher Lamp, LH (Rear)	RG	Regenerative Resistor
D _{CH}	Charger Diode	L _{F-R}	Flasher Lamp, RH	RAD/P	Drive/Pump Absorber Resistor
DC-SDD	DC-DC Converter & Source Drive (Drive)	L _{F-RR}	Flasher Lamp, RH (Rear)	SA	Surge Absorber
DC-SDP	DC-DC Converter & Source Drive (Pump)	L _{H-L}	Head Lamp, LH	SDD	Drive SIT Driver
DF1/2	FLY-WHEEL Diode, No.1/2	L _{H-R}	Head Lamp, RH	SDP	Pump SIT Driver
DF3/4	FLY-WHEEL Diode No.3/4	L _{R-F}	Rotaly Forward Lamp	SLL	Lequid Level Sensor
DG	Regenerative Diode	L _{R-R}	Rotaly Reverse Lamp	SN1	Snubber No. 1
DISP	Display	LS _{ATT1/2}	Attachment Limit Switch No.1/2	SSP	Speed Sensor
DM _{D/P}	Drive/Pump Motor	LS _B	Brake Limit Switch	ST	Steering Torque Sensor
DM _{PS}	Power Steering Motor	LS _D	Dead Man Limit Switch	STH	Thermo Sensor
DS _{BU}	Back-Up Direction Switch	LS _{L 1/2}	Lift Limit Switch No.1/2	SW _{AC}	Accel Switch
DS _F	Forward Direction Switch	LS _{PB}	Parking Brake Limit Switch	SW _F	Flasher Switch
DS _{FO}	Forward Optional Direction Switch	LS _{ST}	Stop lamp limit Switch	SW _H	Horn Switch
DS _R	Reverse Direction Switch	L _{ST-L}	Stop Lamp, LH	SW _{KY}	Key Switch
F1	Drive Fuse	L _{ST-R}	Stop Lamp, RH	SW _L	Light Switch
F2	Pump Fuse	LS _T	Tilt Limit Switch	SW _{SC}	Speed Control Switch
F3	Power Steering Fuse	L _{T-L}	Tail Lamp, LH	TF	Transformer
F4	Lamp Fuse	L _{T-R}	Tail Lamp, RH	TG	Regenerative Transistor
F5	Control Circuit Fuse	L _W	Working Lamp	THR	Thermal Relay
F _{CH}	Charger Fuse	MF	Forward Contactor	TM	Main Transistor
		MG	Regenerative Contactor	TMP	Main Pump Transistor
		MP	Pump Contactor	TM _{PS}	Main Power Steering Transistor
		M _{PS}	Power Steering Contactor	TU	Timer Unit
		MR	Reverse Contactor	VRAD	Accel Drive Vari-Ohm
		MS	Short Contactor		

OPERATIONAL TIPS

1. Safe operation

- (1) After jacking up, always support with rigid stands.
- (2) When hoisting the vehicle or its heavy component, use wire rope(s) with a sufficient reserve in load capacity.
- (3) Always disconnect the battery plugs before the inspection or servicing of electrical parts.

2. Tactful operation

- (1) Prepare the mechanic tools, necessary measuring instruments (circuit tester, megger, oil pressure gauge, etc.) and SSTs before starting operation.
- (2) Before disconnecting wiring, always check the cable color and wiring state.
- (3) When overhauling functional parts, complicated portions or related mechanisms, arrange the parts neatly to prevent confusion.
- (4) When disassembling and inspecting such a precision part as the control valve, use clean tools and operate in a clean location.
- (5) Follow the described procedures for disassembly, inspection and reassembly.
- (6) Replace, gaskets, packings and O-rings with new ones each time of disassembly.
- (7) Use genuine Toyota parts for replacement.
- (8) Use specified bolt and nuts. Observe the specified tightening torque at the time of reassembly. If no tightening torque is specified, tighten the bolt or nut according to the standard tightening torque table.

3. Grasping the trouble state

When a trouble occurs, do not attempt immediate disassembly or replacement but first check if the trouble requires disassembly or replacement for remedying.

CIRCUIT TESTER

Circuit testers are available in both the analog and digital types. They should be used selectively according to the purpose of measurement.

Analog type: This type is convenient for observing movement during operation, but the measured value should only be used for reference or rough judgement.

Digital type: Fairly accurate reading is possible, but it is difficult to observe the variation or movement.

1. Difference in measurement results with the digital type and analog type
 - * The result may be different between measurements with the analog type and digital type. Always use a circuit tester according to its operation manual. Cautions when the polarities are different between the analog type and digital type are described below.

Circuit tester range: Analog type → kohm range Digital type → 2 Mohm range

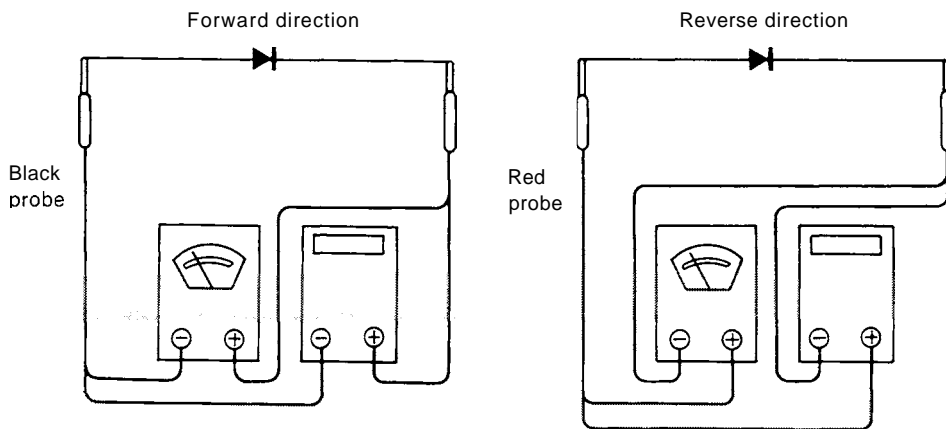

Measurement result example

	Analog type	Digital type
Forward	Continuity shall exist	No continuity
	11 KΩ	1
Reverse	No continuity	Continuity shall exist
	∞	2 MΩ

As seen from the example above, the measurement results with the analog and digital types are reverse. In measurement with a digital type circuit tester, therefore, use the tester probes as shown below.

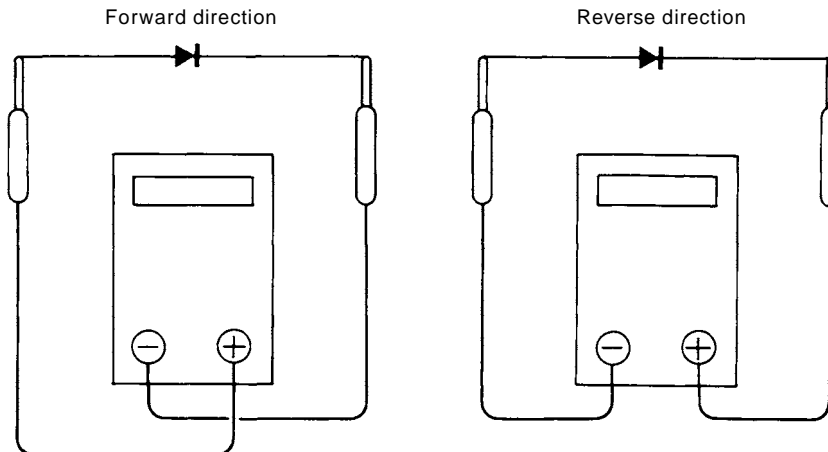

2. Difference in result of measurement with circuit tester

The circuit tester power supply voltage depends on the tester type. 1.5V, 3.0V or 6.0V is used. The resistance of a semiconductor such as a diode varies with the circuit tester power supply voltage.

The diode characteristics are shown in the figure below.

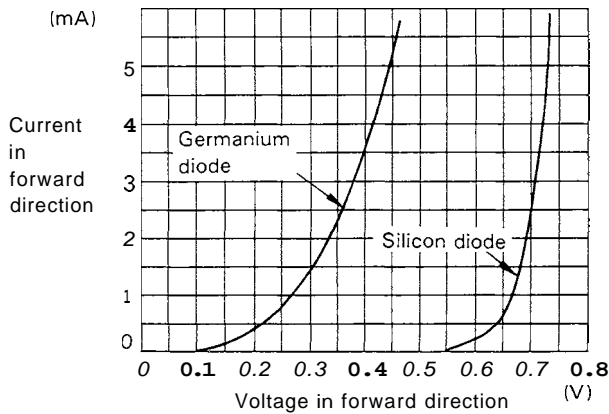

The resistance values of the same semiconductor measured with two types of circuit testers having different power supply voltages are different.

This manual describes the results of measurement with a circuit tester whose power supply voltage is 3.0 V.

3. Difference in measurement result by measurement range (analog type)

In the analog type circuit tester, changing the measurement range switches over the internal circuit to vary the circuit resistance. Even when the same diode is measured, the measurement result varies with the measurement range.

Always use the range described in the repair manual for measurement.

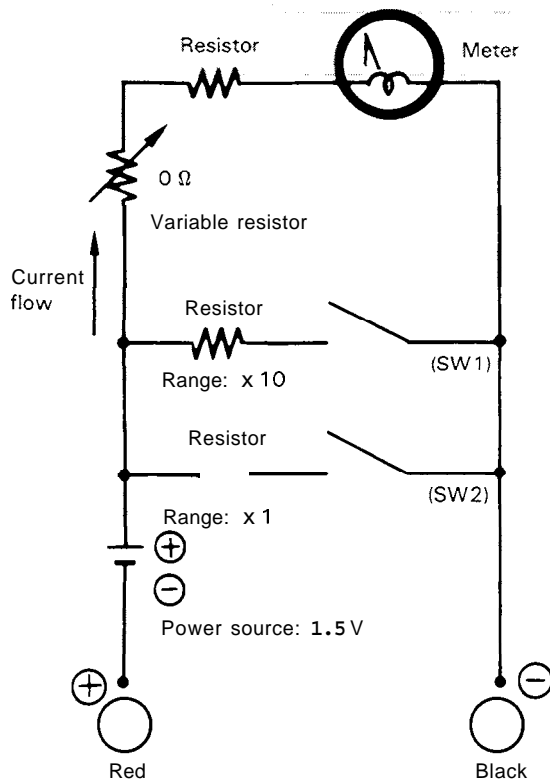







STANDARD BOLT & NUT TIGHTENING TORQUE

Standard bolt and tightening torques are not indicated.
Judge the standard tightening torque as shown below.

1. Find out the type of the bolt from the list below and then find the bolt tightening torque from the table.
2. The nut tightening torque can be judged from the mating bolt type.

BOLT STRENGTH TYPE IDENTIFICATION METHOD

1. Identification by bolt shape

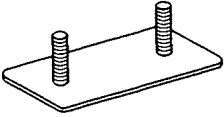
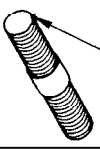
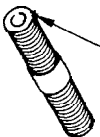
	Shape and class	Class
Hexagon head bolt	 Bolt head No.	4 = 4T 5 = 5T 6 = 6T 7 = 7T
	 No mark	4T
Hexagon flange bolt	 No mark	4T
Hexagon head bolt	 Two protruding lines	5T
Hexagon flange bolt	 Two protruding lines	6T
Hexagon head bolt	 Three protruding lines	7T
Welded bolt		4T
Stud bolt	 No mark	4T
	 Grooved	6T

2. Identification by part No.

Hexagon head bolt

Parts No. 91611-40625

Length (mm)
Diameter (mm)
Class

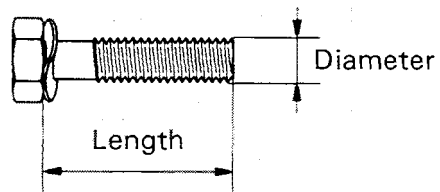



Stud bolt

Parts No. 92132-40614

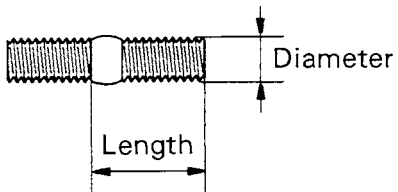
Length (mm)
Diameter (mm)
Class



TIGHTENING TORQUE TABLE

Class	Diameter mm	Pitch mm	Specified torque					
			Hexagon head bolt 			Hexagon flange bolt 		
			N·m	kg-cm	ft-lb	N·m	kg-cm	ft-lb
4T	6	1.0	5.4	55	48 in-lb	5.9	60	52 in-lb
	8	1.25	13	130	9	14	145	10
	10	1.25	25	260	19	28	290	21
	12	1.25	47	480	35	53	540	39
	14	1.5	75	760	55	83	850	61
	16	1.5	113	1150	83	—	—	—
5T	6	1.0	6.4	65	56 in-lb			
	8	1.25	16	160	12			
	10	1.25	32	330	24	—	—	—
	12	1.25	59	600	43			
	14	1.5	91	930	67			
	16	1.5	137	1400	101			
6T	6	1.0	7.8	80	69 in-lb	8.8	90	78 in-lb
	8	1.25	19	195	14	21	215	16
	10	1.25	39	400	29	43	440	32
	12	1.25	72	730	53	79	810	59
	14	1.5	—	—	—	123	1250	90
7T	6	1.0	11	110	8	12	120	9
	8	1.25	25	260	19	28	290	21
	10	1.25	52	530	38	58	590	43
	12	1.25	95	970	70	103	1050	76
	14	1.5	147	1500	108	167	1700	123
	16	1.5	226	2300	166	—	—	—

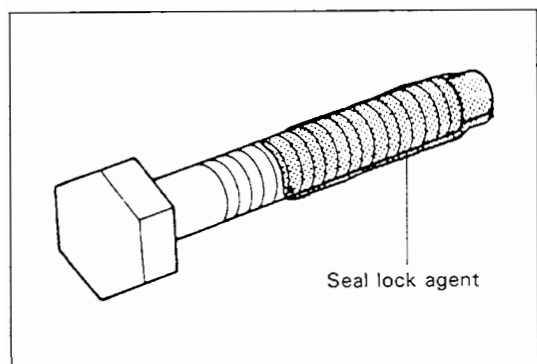

PRECOAT BOLTS

(Bolts with seal lock agent coating on threads)

1. Do not use the precoat bolt as it is in either of the following cases.
 - (a) After is removed.
 - (b) When the precoat bolt is moved (loosened or tightened) by tightness check, etc.

Note:

For torque check, use the lower limit of the allowable tightening torque range. If the bolt moves, retighten it according to the steps below.

2. Method for reuse of precoat bolts
 - (1) Wash the bolt and threaded hole. (The threaded hole must be washed even for replacement of the bolt.)
 - (2) Perfectly dry the washed parts by air blowing.
 - (3) Coat the specified seal lock agent to the threaded portion of the bolt.

HIGH PRESSURE HOSE FITTING TIGHTENING TORQUE

1. When connecting a high pressure hose, wipe the hose fitting and mating nipple contact surfaces with clean cloth to remove foreign matters and dirt. Also check no dent or other damage on the contact surfaces before installation.
2. When connecting a high pressure hose, hold the hose to align the fitting with the nipple and tighten the fitting.
3. The maximum tightening torque must not exceed twice the standard tightening torque.

Nominal diameter of screw	Standard tightening torque N·m (kgf·cm) [ft·lbf]		Hose inside diameter mm (in)
	Standard	Tightening range	
7/16 – 20UNF	25 (250) [18.11	24 – 26 (240 – 270) [17.4 ~ 19.5]	6 (0.24)
9/16 – 18UNF	49 (500) [36.21	47 – 52 (480 – 530) [34.7 ~ 38.3]	9 (0.35)
3/4 – 16UNF	59 (600) [43.41	56 – 62 (570 – 630) [41.2 ~ 45.6]	12 (0.47)
7/8 – 14UNF	59 (600) [43.41	56 – 62 (570 – 630) [41.2 – 45.61	12 (0.47), 15 (0.59)
1-1/16 – 12UNF	118 (1200) [86.81	112 ~ 123 (1140 ~ 1250) [82.5 ~ 90.41	19 (0.75)
1-5/16 – 12UNF	137 (1400) [101.3]	130 – 144 (1330 – 1470) [96.2 ~ 106.4]	25 (0.98)
PF1/4	25 (250) [18.11	24 – 26 (240 – 270) 117.4 ~ 19.51	6 (0.24)
PF3/8	49 (500) [36.2]	47 – 52 (480 – 530) [34.7 ~ 38.31	9 (0.35)
PF1/2	59 (600) [43.41	56 – 62 (570 – 630) [41.2 ~ 45.61	12 (0.47)
PF3/4	118 (1200) [86.81	112 – 123 (1140 – 1250) [82.5 ~ 90.41	19 (0.75)
PF1	137 (1400) [101.3]	130 – 144 (1330 ~ 1470) 196.2 ~ 106.41	25 (0.98)

WIRE ROPE SUSPENSION ANGLE LIST

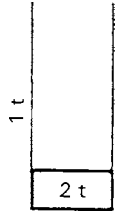
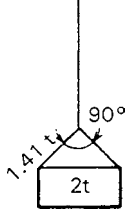
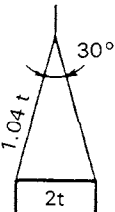
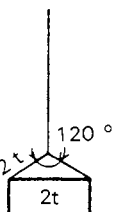
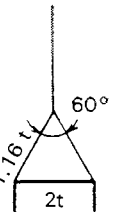
Lifting angle	Tension	Compression	Suspension method	Lifting angle	Tension	Compression	Suspension method
0°	1.00 time	0 time		90°	1.41 time	1.00 time	
30°	1.04 time	0.27 time		120°	2.00 time	1.73 time	
60°	1.16 time	0.58 time					

SAFE LOAD FOR EACH WIRE ROPE SUSPENSION ANGLE

Unit: N (ton)[lb]

Rope diameter	Cutting load	Single-rope suspension	Two-rope suspension					Four-rope suspension			
			0°	0°	30°	60°	90°	0°	30°	60°	90°
6 mm (0.24 in)	21380 (2.18) [4807]	3040 (0.31) [683.6]	6080 (0.62) [1367]	5880 (0.6) [1323]	5200 (0.53) [11691]	4310 (0.44) [970]	12160 (1.24) [2734]	11770 (1.2) [2646]	10400 (1.06) [2337]	8630 (0.88) [19401]	
8 mm (0.32 in)	31480 (3.21) [7078]	4410 (0.45) [992.3]	8830 (0.9) [1985]	8530 (0.87) [1918]	7650 (0.78) [1720]	6280 (0.64) [1411]	17650 (1.8) [3969]	17060 (1.74) [3937]	15300 (1.56) [3440]	12550 (1.28) [2322]	
10 mm (0.4 in)	49230 (5.02) [11.691]	6960 (0.71) [1565.6]	14020 (1.43) [3153]	13440 (1.37) [3021]	11770 (1.2) [2646]	9810 (1.0) [2205]	27460 (2.8) [6174]	26480 (2.7) [5954]	23540 (2.4) [5292]	19610 (2.0) [4410]	
12.5 mm (0.5 in)	76880 (7.84) [17387]	10980 (1.12) [2469.5]	21570 (2.2) [4851]	21280 (2.1) [4631]	18630 (1.9) [4190]	14710 (1.5) [3308]	43150 (4.4) [9702]	41190 (4.2) [9261]	37270 (3.8) [8379]	29420 (3.0) [6615]	
14 mm (0.56 in)	96400 (9.83) [21675]	13730 (1.4) [3087]	27460 (2.8) [6174]	26480 (2.7) [5954]	23540 (2.4) [5292]	18630 (1.9) [4190]	54920 (5.6) [123481]	52960 (5.4) [119071]	47070 (4.8) [105841]	37270 (3.8) [8379]	

COMPONENTS WEIGHT

Item		Model	Weight N (kg) [lb]
Motor	Drive	1 ton series	Approx. 735 (75) [165] Only dustproof model: Approx. 834 (85) [187]
		2 ton series	Approx. 1079 (110) [243]
		3 ton series	Approx. 1079 (110) [243]
	Material handling	1 ton series	Approx. 441 (45) [99]
		2 ton series	Approx. 637 (65) [143]
		3 ton series	Approx. 637 (65) [143]
Balance weight		5FBC13	Approx. 2746 (280) [617]
		5FBC15	Approx. 4315 (440) [670]
		5FBC18	Approx. 4021 (410) [904]
		5FBC20	Approx. 4707 (480) [1058]
		5FBC25	Approx. 8090 (825) [1819]
		5FBC28	Approx. 6816 (695) [1532]
		5FBC30	Approx. 8090 (825) [1819]
		5FBH20	Approx. 4021 (410) [904]
		5FBH25	Approx. 4707 (480) [1058]
Mast W/ lift bracket (with lift cylinder, less back rest and fork) [max. fork height = 3000 mm (118 in)]		1 ton series	Approx. 3825 (390) [860]
		2 ton series	Approx. 4511 (460) [1014]
		3 ton series	Approx. 5884 (600) [1323]

RECOMMENDED LUBRICANTS AND CAPACITIES

Application	Type	Capacity	
Differential & transmission	STD: Hypoid gear oil SAE85W-90 (API GL-4)	1 ton series	7.0 l (1.85 US gal.)
	45S: Hypoid gear oil w (API GL-4)	2 - 3 ton series	7.5 l (1.98 US gal.)
Hydraulic (total)	STD: Hydraulic oil ISO VG32	1 ton series	* 16 l (4.2 US gal.) ** 21 l (5.5 US gal.)
	45S: MIL-H-5606-D	2 - 3 ton series	" 20 l (5.3 US gal.) " 26 l (6.9 US gal.)
Brake line	STD: SAE J-1703 DOT-3 45S: Brake fluid artic S	Proper quantity	
Chassis part	STD: MP grease No.2 45S: Esso beacon 325	Proper quantity	

45S: Refrigerator specification vehicle

*: For 3000 mm (118 in) maximum fork height

** : For 6000 mm (236 in) maximum fork height

LUBRICATION CHART

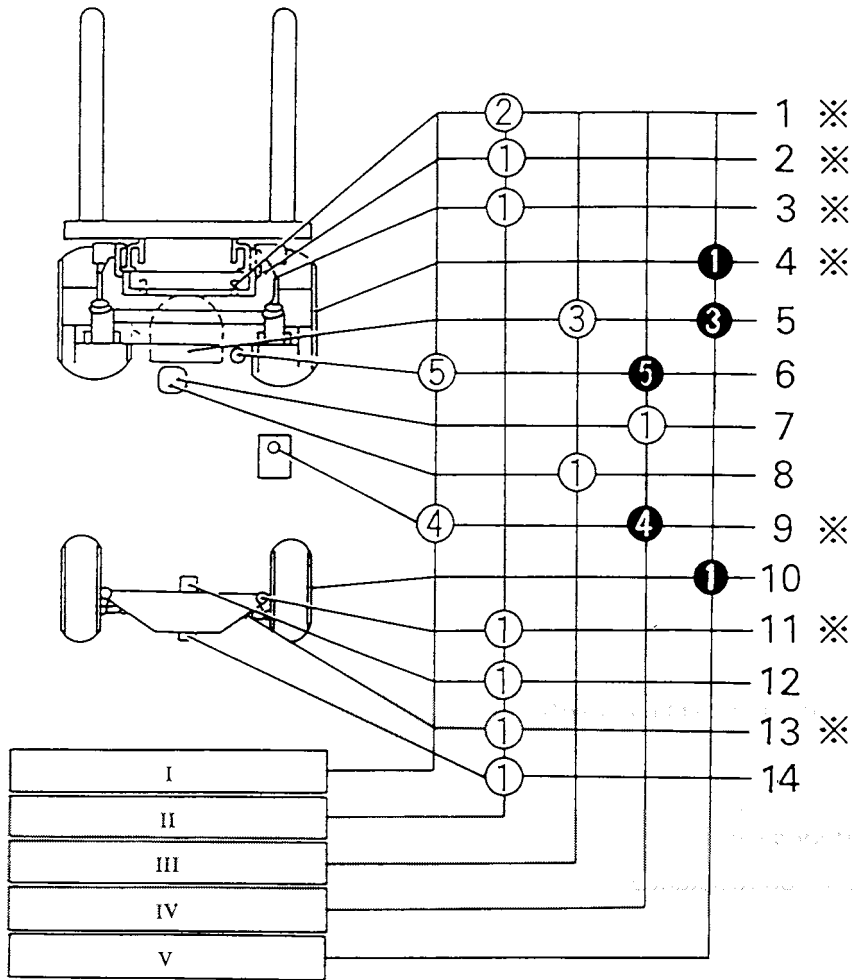

- 1. Chain
- 2. Mast support bushing
- 3. Tilt cylinder front pin
- 4. Front wheel bearing
- 5. Differential & transmission
- 6. Brake fluid reservoir tank
- 7. Tilt steering locking mechanism
- 8. Tilt steering universal joint
- 9. Oil tank
- 10. Rear wheel bearing
- 11. Steering knuckle king pin
- 12. Rear axle beam front
- 13. Rear axle cylinder rod joint (1 ton series)
- 14. Rear axle beam rear

* Located on right and left sides

- I Inspect every 8 hours (daily)
- II Inspect every 40 hours (weekly)
- III Inspect every 170 hours (monthly)
- IV Inspect every 1000 hours (6 monthly)
- V Inspect every 2000 hours (annually)

- Inspect and service
- Replace

- 1. MP grease
- 2. Engine oil
- 3. Hypoid gear oil
- 4. Hydraulic oil
- 5. Brake fluid

PERIODIC MAINTENANCE

INSPECTION METHOD

I: Inspection. Repair or replacement if required.
 M: Measurement. Repair or adjustment if required.
 T : Retightening C: Cleaning L: Lubrication
 * : For new vehicle * 1: Flaw detector

Item	Inspection Period	Months	1	3	6	12
		Hours	170	500	1000	2000
ELECTRICAL SYSTEM						
Motor	Abnormal sound during revolution	I	○	○	○	○
	Loose terminal	T	○	○	○	○
	Insulation resistance	M		○	○	○
	Brush wear and sliding contact status	I			○	○
	Commutator fouling and damage	I			○	○
	Brush spring fatigue	M				○
Battery	Charge	I	○	○	○	○
	Battery fluid level	I	○	○	○	○
	Battery fluid specific gravity	M	○	○	○	○
	Loose terminal	I	○	○	○	○
	Abnormality at top of battery and battery case	I	○	○	○	○
	Insulation resistance	M		○	○	○
	Cell voltage measurement after charging	M				○
Charger	Timer operation	I	○	○	○	○
	Terminal loosening	I	○	○	○	○
	Operating voltage measurement	M		○	○	○
	Magnet switch function, contact fouling and roughening	I				○
Magnet contactor	Loose contact, damage and wear	I	○	○	○	○
	Auxiliary contact function, fouling and wear	I	○	○	○	○
	Arc chute installation status	I				○
	Timing and functioning	I				○
	Loose coil installation	I				○
	Loose main circuit lead installation	I				○
Microswitch	Timing and operating function	I	○	○	○	○
	Damage and loose installation	I	○	○	○	○

Item		Inspection Period		1	3	6	12
		Months	Hours	170	500	1000	2000
Direction lever	Operating conditions and damage	I		○	○	○	○
Controller	Operation	I		○	○	○	○
	Inside fouling and damage	C		○	○	○	○
	Overcurrent limit valve	M					○
Fuse	Loosening	I		○	○	○	○
Wiring (including charging cord)	Damage of wiring harness and loose clamp	I		○	○	○	○
	Loose connection and taping status	I		○	○	○	○
	Battery connector damage and connection status	I		○	○	○	○
Accelerator	Operating and damage	I		○	○	○	○
POWER TRAIN							
Differential, Transmission	Oil leak	I		○	○	○	○
	Oil level	I		○	○	○	○
	Loosening of nuts and bolts	T					○
TRAVELING EQUIPMENT							
Wheels	Tire cuts, damage and uneven wearing	I		○	○	○	○
	Loose rim and hub nuts	T		○	○	○	○
	Tire groove depth	M		○	○	○	○
	Metal chips, pebbles and other foreign matter trapped in tire grooves	I		○	○	○	○
	Rim and disc wheel damage	I		○	○	○	○
	Abnormal sound and looseness of front wheel bearing	I		○	○	○	○
	Abnormal sound and looseness of rear wheel bearing	I		○	○	○	○
Front axle	Cracks, damage and deformation of housing	I					○
Rear axle	Cracks, damage and deformation of beam	I					○
	Looseness of axle beam in vehicle longitudinal direction	M		○*			○

Item		Inspection Period				
		Months	1	3	6	12
		Hours	170	500	1000	2000
STEERING SYSTEM						
Steering wheel	Play and looseness	I	○	○	○	○
	Function	I	○	○	○	○
Gear box	Oil leak	I	○	○	○	○
	Looseness of mounting	T	○	○	○	○
Power steering	Oil leak	I	○	○	○	○
	Damage of power steering hose	I				○
Knuckle	King pin looseness	I	○	○	○	○
	Cracks and deformation	I				○
Steering shaft	Wheel alignment	M				○
	Left and right turning angle	M				○
BRAKING SYSTEM						
Brake pedal	Play and reserve	M	○	○	○	○
	Braking effect	I	○	○	○	○
Parking brake	Pull margin	I	○	○	○	○
	Braking effect	I	○	○	○	○
	Rod and cable looseness and damage	I	○	○	○	○
	Ratchet wear and damage	I				○
Brake pipe and hose	Leakage, damage and mounting status	I	○	○	○	○
Brake fluid	Fluid level	I	○	○	○	○
Master cylinder or brake valve and wheel cylinder	Function, wear, damage, leak and mounting looseness	I				○
Brake drum and brake shoe	Clearance between drum and lining	M	○	○	○	○
	Wear of shoe sliding portion and lining	I				○
	Drum wear and damage	I				○
	Shoe operation condition	I				○
	Anchor pin rusting	I				○
	Return spring fatigue	M				○
	Automatic adjuster function	I				○
Backing plate	Deformation, cracks and damage	I				○
	Loose mounting	T				○

Item		Inspection Period		Months	1	3	6	12
		Hours	170	500	1000	2000		
MATERIAL HANDLING SYSTEM								
Forks	Abnormality of fork and stopper pin	I	○	○	○	○	○	○
	Misalignment between left and right fork fingers	I	○	○	○	○	○	○
	Cracks at fork root and welded part	I* ¹						○
Mast and fork bracket	Deformation and damage of each part and crack at welded part	I	○	○	○	○	○	○
	Mast and lift bracket looseness	I	○	○	○	○	○	○
	Wear and damage of mast support bush	I						○
	Wear, damage and rotating condition of rollers	I	○	○	○	○	○	○
	Wear and damage of roller pins	I						○
	Wear and damage of mast strip	I	○	○	○	○	○	○
Chain and chain wheel	Tension, deformation and damage of chain	I	○	○	○	○	○	○
	Chain lubrication	I	○	○	○	○	○	○
	Abnormality of chain anchor bolt	I	○	○	○	○	○	○
	Wear, damage and rotating condition of chain wheel	I	○	○	○	○	○	○
Various attachments	Abnormality and mounting condition of each part	I	○	○	○	○	○	
HYDRAULIC SYSTEM								
Cylinder	Loosening and damage of cylinder mounting	I	○	○	○	○	○	○
	Deformation and damage of rod, rod screw and rod end	I	○	○	○	○	○	○
	Cylinder operation	I	○	○	○	○	○	○
	Natural drop and natural forward tilt (hydraulic drift)	I	○	○	○	○	○	○
Cylinder	Oil leak and damage	I	○	○	○	○	○	○
	Wear and damage of pin and cylinder bearing	I	○	○	○	○	○	○
	Lifting speed	M	○	○	○	○	○	○
	Uneven movement	I	○	○	○	○	○	○
Oil pump	Oil leak and abnormal sound	I	○	○	○	○	○	
Hydraulic oil tank	Oil level and contamination	I	○	○	○	○	○	○
	Tank and oil strainer	C			○	○	○	
	Oil leak	I	○	○	○	○	○	

Item		Inspection Period		1	3	6	12
		Months	Hours	170	500	1000	2000
Control lever	Loose linkage	I		○	○	○	○
	Operation	I		○	○	○	○
Oil control valve	Oil leak	I		○	○	○	○
	Relief pressure measurement	M					○
	Relief valve and tilt lock valve functions	I		○	○	○	○
Hydraulic piping	Oil leak	I		○	○	○	○
	Deformation and damage	I		○	○	○	○
	Loose joint	T		○	○	○	○
	Hoise tension and twisting	I		○	○	○	○
SAFETY DEVICES, ETC.							
Head guard	Cracks at welded portion	I		○	○	○	○
	Deformation and damage	I		○	○	○	○
Back-rest	Loosening of mounting	T		○	○	○	○
	Deformation, crack and damage	I		○	○	○	○
Lighting system	Function and mounting condition	I		○	○	○	○
Horn	Function and mounting condition	I		○	○	○	○
Direction indicator	Function and mounting condition	I		○	○	○	○
Instrunenrs	Functions	I		○	○	○	○
Back up buzzer	Function and mounting condition	I		○	○	○	○
Rear-view mirror	Dirt, damage	I		○	○	○	○
	Rear reflection status	I		○	○	○	○
Seat	Loosening and damage of mounting	I		○	○	○	○
Body	Damage and cracks of frame, cross members, etc.	I					○
	Bolt looseness	T					○
Other	Grease up	L		○	○	○	○



Suggest:

For more complete manuals. Please go to the home page.

<https://www.ebooklibonline.com>

If the above button click is invalid. Please download this document first, and then click the above link to download the complete manual.

Thank you so much for reading

PERIODIC REPLACEMENT OF PARTS AND LUBRICANTS

Inspection (operating hours or months, whichever is earlier)	Months	1	3	6	12
	Hours	170	500	1000	2000
Brake fluid				●	●
Hydraulic oil				●	●
Hydraulic oil return filter		a (New vehicle)		a	a
Differential and transmission oil					●
Wheel bearing grease					●
Master cylinder rubber parts					●
Wheel cylinder rubber parts					●
Reserve tank hose					● (Every 2 years)
Power steering hose					● (Every 2 years)
Internal rubber parts of power steering system					● (Every 2 years)
Material handling hose					● (Every 2 years)
Chain					● (Every 3 years)

BATTERY

	Page
SERVICE STANDARDS	1-2
DISPLAY INDICATION	1-2
OVERDISCHARGE ALARM FUNCTION	1-2
BATTERY COMPARTMENT & MINIMUM WEIGHT REQUIRED	1-3
TROUBLESHOOTING	1-4
BATTERY ASSY	1-5
REMOVAL-INSTALLATION	1-5
INSPECTION	1-6

<https://www.ebooklibonline.com>

Hello dear friend!

Thank you very much for reading.

Enter the link into your browser.

The full manual is available for immediate download.

<https://www.ebooklibonline.com>