

FOREWORD

This repair manual covers the inspection, adjustment and repair procedures for the overhaul of the engine, chassis and materials handling system of the TOYOTA SKID STEER LOADER 2SGK6, 2SDK6, 2SDK7 and 2SDK8.

You are encouraged to become thoroughly familiar with this manual so as to make the most of the outstanding performance and durability features of these loaders and to perform the proper servicing to maintain them in tip-top running condition.

This repair manual contains the latest information available as of March, 1986. For any changes thereafter, you are asked to consult the Parts & Service News. Toyota reserves the right to make changes in specifications without incurring any obligation and without previous notice.

For your reference, we herewith indicate the titles of relevant manuals.

TOYOTA 4P ENGINE REPAIR MANUAL (No. 95721)

TOYOTA 2J, 2J-T ENGINE REPAIR MANUAL (No. 95727)

TOYOTA 3T84H ENGINE REPAIR MANUAL (No. 95731)

TOYOTA MOTOR CORPORATION

SECTION INDEX

	SECTION
GENERAL	0
ENGINE	1
HYDROSTATIC TRANSMISSION	2
FINAL REDUCTION GEAR	3
STEERING	4
AXLE	5
BRAKES	6
BODY FRAME	7
LIFT ARMS & BUCKET BRACKET	8
CYLINDERS	9
OIL PUMP	10
OIL CONTROL VALVE	11
HYDRAULIC SYSTEM	12
SST LIST	13

GENERAL

	Page
VEHICLE EXTERIOR VIEWS	0-2
VEHICLE MODELS	0-3
ABBREVIATION	0-3
TIPS ON OPERATION	0-4
RIGHT ORDER OF OPERATION	0-4
STANDARD BOLT & NUT TIGHTENING TORQUE ..	0-5
STANDARD HIGH-PRESSURE HOSE FITTING TIGHTENING TORQUE	0-7
FRAME SERIAL NUMBER	0-7
VEHICLE DIMENSIONS	0-8
GENERAL SPECIFICATIONS	0-12
RECOMMENDED LUBRICANTS & CAPACITIES	0-14
PERIODIC MAINTENANCE	0-15
LUBRICATION	0-20

0

<https://www.ebooklibonline.com>

Hello dear friend!

Thank you very much for reading.

Enter the link into your browser.

The full manual is available for immediate download.

<https://www.ebooklibonline.com>

VEHICLE MODELS

Model	Engine	Operating Load	Bucket Capacity	Machine Weight
2SGK6	TOYOTA 4P	460 kg (1000 lbs)	0.28 m ³ (10.0 ft ³)	2100 kg (4630 lbs)
2SDK6	YANMAR 3T84H	460 kg (1000 lbs)	0.28 m ³ (10.0 ft ³)	2100 kg (4630 lbs)
2SDK7	TOYOTA 2J	520 kg (1150 lbs)	0.31 m ³ (11.0 ft ³)	2200 kg (4850 lbs)
2SDK8	TOYOTA 2J	600 kg (1320 lbs)	0.34 m ³ (12.0 ft ³)	2490 kg (5490 lbs)

ABBREVIATION

Abbreviation (Code)	Measuring
ABDC	After bottom dead center
ASSY	Assembly
ATDC	After top dead center
BBDC	Before bottom dead center
BTDC	Before top dead center
CCA	Cold cranking amperes
HST	Hydrostatic transmission
LH	Left hand
OHV	Over head valve
OPT	Option
OR	Off road
PR	Ply rating
RH	Right hand
SAE	Society of Automotive Engineers (USA)
SST	Special service tool
SUB-ASSY	Sub-assembly
T =	Tightening torque
OT	No gear teeth

TIPS ON OPERATION

1. Safe operations
 - (1) Carry out inspections and servicing with the lift arm lowered and the bucket on the ground. If such work must be performed with the lift arm in the air, support it with the lift arm lock pin, or use the safety block or safety pillar to prevent the arm from lowering.
 - (2) Always use rigid racks or stands when jacking up the vehicle.
 - (3) When lifting with a wire rope, make sure the rope is sufficiently strong.
2. SST & measuring tools
Have the mechanic tools, SST and measuring tools on hand.
3. Order & arrangement
 - (1) Always arrange things in an orderly manner for easy operations.
 - (2) Disassembly of the hydraulics should be done with clean tools in a clean area.
4. Troubleshooting
Do not immediately disassemble when trouble occurs; first determine whether or not disassembly is necessary. For example, with the HST, the pump should not be immediately turn down simply because there is trouble with the travel system. Troubleshoot the cause in the steering levers, the final reduction gear, the change oil pressure, the hydraulic oil and so on.

RIGHT ORDER OF OPERATION

1. Disassembly
Mark or punch mating marks in a feasible location so as to facilitate disassembly of a complex unit. Also, if you are repairing electricals, be sure to disconnect the cables from the battery terminals. Always start with (-) terminal without fail when disconnecting cables from the battery terminals.
2. Inspections during disassembly
In removing each and every part, check for the installed condition, deformation, breakage, roughness or damage.
3. Assembly and installation
 - (1) Always adhere to the tightening torques listed. If none are given, follow the "Standard Tightening Torques."
 - (2) When reassembling after disassembly, use Toyota Genuine Parts to replace packings, gaskets and O-rings.
 - (3) Apply a seal packing in terms of the gasket position, and coat the sliding surfaces at the specified locations with the recommended oil; apply the recommended grease and also coat oil seal lips with MP grease, when assembling.









STANDARD BOLT & NUT TIGHTENING TORQUE

Standard bolt and nut tightening torques are not indicated; therefore tightening torque must be judged as below:

1. Find out the type of the bolt from the list below.
Then, find the bolt tightening torque from the table.
2. The nut tightening torque can be judged from the bolt type. (See the table.)

List of Bolt Types and Strength

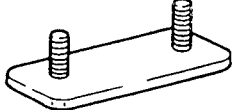
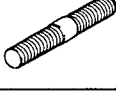
1. Judging by part

Shape and description		Type
Hexagon bolt	 Number in relief or hallmark on the head	4 = 4T 5 = 5T 6 = 6T 7 = 7T
Standard bottom surface	 No mark	4T
Hexagon bolt (Collared bottom)	 No mark	4T
Hexagon bolt (Standard bottom surface)	 Two relief lines on the head	5T
Hexagon bolt (Collared bottom)	 Two relief lines on the head	6T
Hexagon bolt	 Three relief lines on the head	7T
Welded bolt		4T
Welding bolt	 No mark	4T
Stud bolt	 Approximately 2 mm (0.08") hollow on either or both ends	6T

2. Judging by part No.

Hexagon bolt

Sample number
91111-40610

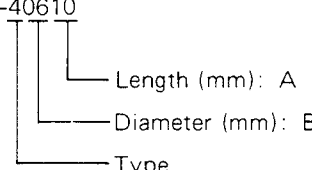

Length (mm): A
Diameter (mm): B
Type

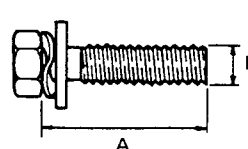

Stud bolt

Sample number
92132-40614

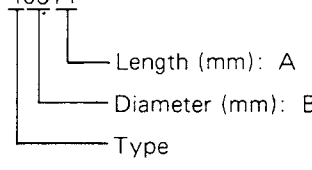

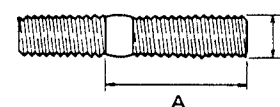

Length (mm): A
Diameter (mm): B
Type



BAHS28

BAHS25

Standard Bolt Tightening Torque

Type	Diameter mm	Pitch mm	Standard tightening torque kg-cm (ft-lb)	
			Standard seat 	Seat with flange 
4 T	6	1.0	55 (4.0)	60 (4.3)
	8	1.25	130 (9.4)	140 (10.5)
	10	1.25	260 (18.8)	290 (20.9)
	12	1.25	480 (34.7)	540 (39.0)
	14	1.5	760 (54.9)	850 (61.4)
	16	1.5	1,150 (83.0)	—
5 T	6	1.0	65 (4.7)	—
	8	1.25	160 (11.6)	—
	10	1.25	330 (23.8)	—
	12	1.25	600 (43.3)	—
	14	1.5	930 (67.1)	—
	16	1.5	1,400 (101.1)	—
6 T	6	1.0	80 (5.8)	90 (6.5)
	8	1.25	195 (14.1)	210 (15.2)
	10	1.25	400 (28.9)	440 (31.8)
	12	1.25	730 (52.7)	810 (58.5)
	14	1.5	1,100 (79.4)	1,250 (90.3)
7 T	6	1.0	110 (7.9)	120 (8.7)
	8	1.25	260 (18.8)	290 (20.9)
	10	1.25	530 (38.3)	590 (42.6)
	12	1.25	970 (70.0)	1,050 (75.8)
	14	1.5	1,500 (108.3)	1,700 (122.7)
	16	1.5	2,300 (166.1)	—

BAHS26

STANDARD HIGH-PRESSURE HOSE FITTING TIGHTENING TORQUE

1. When connecting a high-pressure hose, always clean the hose fitting and the opposing nipple with a clean cloth. Check that there are no dents in the contacting surfaces.
2. When connecting a high-pressure hose, always tighten so that the hose fitting and nipple lie in a straight line and not off-center.

Nominal screw diameter	Standard tightening torque kg-m (ft-lb)		Hose inside diameter
	Standard torque	Torque range	
7/16 – 20 UNF	1.65 (11.9)	1.6 ~ 1.7 (11.6 ~ 12.3)	6
9/16 – 18 UNF	3.30 (23.8)	3.1 ~ 3.5 (22.4 ~ 25.3)	9
3/4 – 16 UNF	5.50 (39.7)	5.2 ~ 5.8 (37.5 ~ 41.9)	12
7/8 – 14 UNF	7.80 (56.3)	7.5 ~ 8.1 (54.2 ~ 58.5)	12
1-1/16 – 12 UNF	11.00 (79.4)	10.5 ~ 11.5 (75.8 ~ 83.0)	19
1-5/16 – 12 UNF	15.00 (108.3)	13.9 ~ 16.1 (100.4 ~ 116.2)	25
PF 1/4	3.30 (23.8)	3.1 ~ 3.5 (22.4 ~ 25.3)	9
PF 3/8	5.50 (39.7)	5.2 ~ 5.8 (37.5 ~ 41.9)	9
PF 1/2	7.80 (56.3)	7.5 ~ 8.1 (54.2 ~ 58.5)	12
PF 3/4	11.00 (79.4)	10.5 ~ 11.5 (75.8 ~ 83.0)	19
PF 1	15.00 (108.3)	13.9 ~ 16.1 (100.4 ~ 116.2)	25

FRAME SERIAL NUMBER

1. Frame Serial Number Location

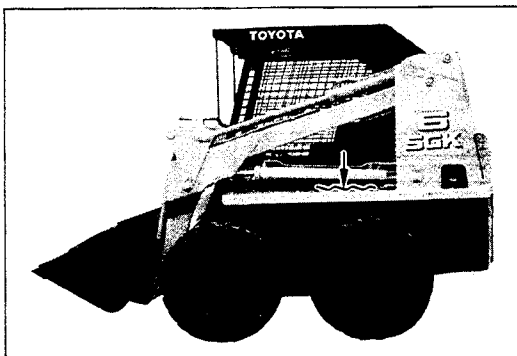

Frame Serial Number Location

SAE45-13

2. Frame Numbering System

Vehicle model	Serial number
2SGK6	2SGK6-10011
2SDK6	2SDK6-10011
2SDK7	2SDK7-10011
2SDK8	2SDK8-10011

VEHICLE DIMENSIONS

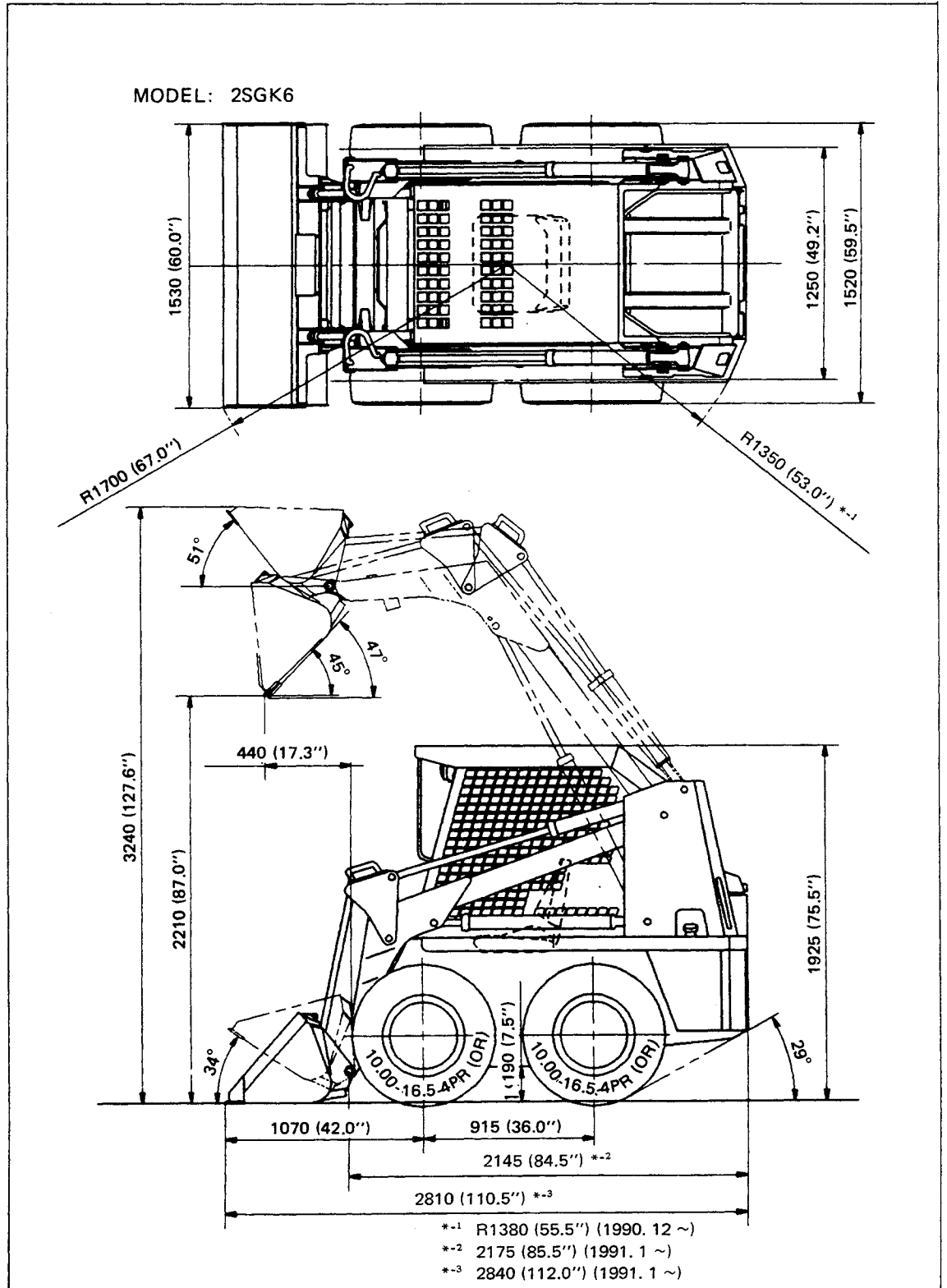

Vehicle Dimensions (2SGK6)

SAEM1

MODEL: 2SDK6

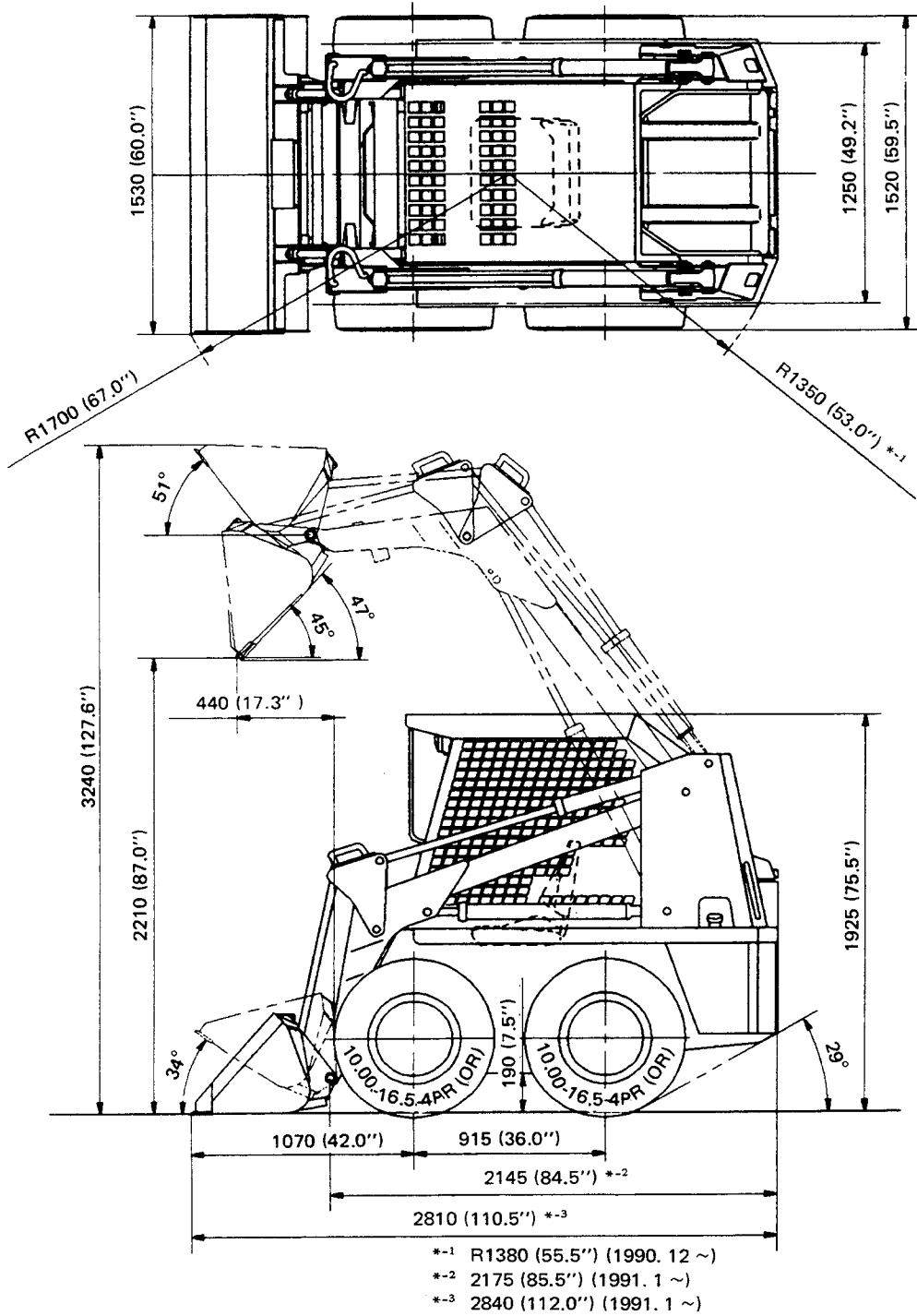

Vehicle Dimensions (2SDK6)

SAEM2

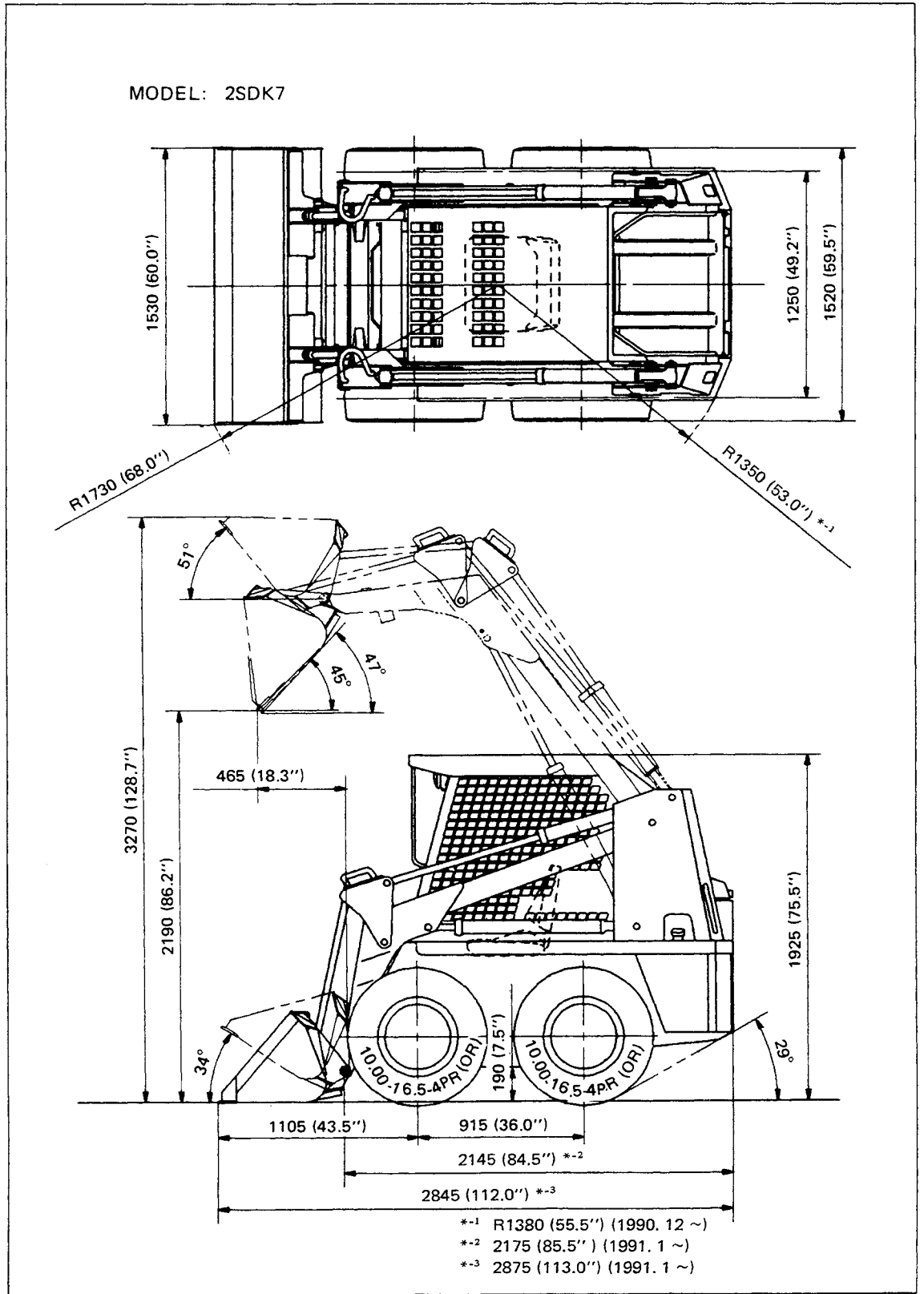

Vehicle Dimensions (2SDK7)

SAEM3

GENERAL SPECIFICATIONS

Item		Vehicle			
		2SGK6	2SDK6	2SDK7	2SDK8
Performance					
Tipping load (SAE)	kg (lbs)	920 (2000)	←	1040 (2290)	1200 (2640)
Operating load (SAE)	kg (lbs)	460 (1000)	←	520 (1150)	600 (1320)
Bucket capacity	m ³ (cu-ft)	0.28 (10.0)	←	0.31 (11.0)	0.34 (12.0)
Dump height (at 45°)	mm (in)	2210 (87.0)	←	2190 (86.2)	2160 (85.0)
Reach-fully raised (at 45°)	mm (in)	440 (17.3)	←	465 (18.3)	490 (19.3)
Dump angle (max)	deg	47	←	←	←
Raising time (Full load)	sec	4.0	←	←	←
Lowering time (No load)	sec	2.5	←	←	←
Dump time (Full load)	sec	2.5	←	←	←
Travel speed km/h (mph)	Forward	10 (6.2)	←	←	←
	Reverse	10 (6.2)	←	←	←
Clearance circle (Bucket)	mm (in)	1700 (67.0)	←	1730 (68.0)	1750 (69.0)
Traction (Full load)	kg (lbs)	2000 (4400)	←	2100 (4650)	2400 (5300)
Gradeability %	Forward	30	←	←	←
	Reverse	58	←	←	←
Engine					
Model		TOYOTA 4P	YANMAR 3T84H	TOYOTA 2J	←
Cylinder	Bore mm (in)	76.6 (3.02)	84 (3.31)	88 (3.46)	←
	Stroke mm (in)	81.0 (3.19)	85 (3.35)	102 (4.02)	←
Piston displacement	cc (cu-in)	1493 (91)	1413 (86)	2481 (151)	←
Rated horsepower	PS/rpm	30/2400	28/2500	40/2500	50/2500
	HP/rpm	38/2600 Gross	27/2500 Net	38/2500 Net	47/2500 Net
Rated torque	kg-m/rpm	10.5/1800	8.5/2000	12.0/2200	14.5/2200
	ft-lbs/rpm	77/2600 Gross	59/2000 Net	83/2200 Net	100/2200 Net
Dimensions					
Overall length (with bucket)	mm (in)	2810 (110.5) ^{*-1}	← ^{*-2}	2845 (112.0) ^{*-3}	2880 (113.5) ^{*-4}
Overall width (without bucket)	mm (in)	1520 (59.5)	←	←	←

Item		Vehicle	2SGK6	2SDK6	2SDK7	2SDK8
Bucket width	mm (in)		1530 (60.0)	←	←	←
Overall height (operator guard)	mm (in)		1925 (75.5)	←	←	←
Wheel base	mm (in)		915 (36.0)	←	←	←
Tread	mm (in)	Front	1250 (49.2)	←	←	←
		Rear	1250 (49.2)	←	←	←
Ground clearance	mm (in)		190 (7.5)	←	←	←
		Center	300 (11.8)	←	←	←
Machine weight (include a full fuel tank and bucket)	kg (lbs)	**5	2100 (4630)	**6 ←	**7 2200 (4850)	**8 2490 (5490)
Controls — Hydrostatic						
Steering	Forward, Reverse, Variable Travel Speed and Steering Controlled by Two Hand Lever					
Drive	Two Hydrostatic Transmission with Infinity Variable Speed					
Fuel System						
Fuel tank capacity	ℓ (US/UK gal)		52 (14/11)	←	←	←
Brake						
Foot brake (OPT) **9			Mechanical	←	←	←
Hand brake			Mechanical	←	←	←
Battery						
Voltage/Capacity	V/AH		12/35	12/80	←	←
	CCA		332	622	←	←
Tires						
Tire size	Front		10.00-16.5-4PR (OR)	←	←	←
	Rear		10.00-16.5-4PR (OR)	←	←	←

* Specifications and design are subject to change without notice.

- **1 2840 (112.0) (1991. 1 ~)
- **2 2840 (112.0) (1991. 1 ~)
- **3 2875 (113.0) (1991. 1 ~)
- **4 2910 (114.5) (1991. 1 ~)
- **5 2130 (4690) (1991. 4 ~)
- **6 2130 (4690) (1991. 4 ~)
- **7 2230 (4920) (1991. 4 ~)
- **8 2520 (5550) (1991. 4 ~)

PERIODIC MAINTENANCE

INSPECTION METHOD

I : Inspect and correct and replace as required. T : Tighten C : Clean
L : Lubricate M ; Measure and correct and adjust as required.

INSPECTION PERIOD

Carry out according to operating hours or months, whichever is soonest.

Inspection Period		Every	1	3	6	12	Months
		Every	170	500	1000	2000	Hours
ENGINE							
Basic components	Starting condition and unusual noise	I	←	←	←		
	Rotating condition during idling	M	←	←	←		
	Rotating condition during acceleration	M	←	←	←		
	Exhaust condition	I	←	←	←		
	Air cleaner element	C	←	←	←		
	Valve clearance	M*				M	
	Compression					M	
Blow by gas Reduction Device	Clogging and damage of PCV valve and piping	I	←	←	←		
Governor	Maximum no-load speed	M	←	←	←		
Lubrication system	Oil leakage	I	←	←	←		
	Oil level	I	←	←	←		
	Clogging and fouling of oil filter	I	←	←	←		
Fuel system	Fuel leakage	I	←	←	←		
	Carburetor link mechanism operation	I	←	←	←		
	Fouling and damage of fuel filter element	I	←	←	←		
	Clogging of feed pump stainer	C	←	←	←		
	Injection timing				M	←	
	Injection nozzle injection pressure and condition					M	
Cooling system	Radiator cooling water level and leakage	I	←	←	←		
	Rubber hose deterioration	I	←	←	←		
	Radiator cap condition	I	←	←	←		
	Fan belt tension and damage	I	←	←	←		

*: For new vehicle

Item		Inspection Period				Months	
		Every	1	3	6	12	
		Every	170	500	1000	2000	Hours
POWER TRANSMISSION SYSTEM							
HST pump and motor	Oil leak	I	←	←	←		
	HST pump and motor operation, abnormal sound	I	←	←	←		
	HST charge pressure measurement		M	←	←		
	HST working pressure measurement		M	←	←		
Reduction gear unit	Oil leak	I	←	←	←		
	Oil level	I	←	←	←		
	Reduction gear operation, abnormal sound	I	←	←	←		
	Chain bush engaged portion deformation		I	←	←		
	Sprocket deformation, damage		I	←	←		
RUNNING EQUIPMENT							
Wheels	Tire air pressure	M	←	←	←		
	Tire cuts, damage and uneven treads	I	←	←	←		
	Loose hub bolts and hub nuts	T	←	←	←		
	Tread depth	M	←	←	←		
	Metal fragments, stones or other foreign objects in tires	I	←	←	←		
	Rim, side ring and disc wheel damage	I	←	←	←		
	Wheel bearing unusual noise and looseness	I	←	←	←		
Axle	Deformation, crack and damage				I		
STEERING SYSTEM							
Steering control lever	Looseness	I	←	←	←		
	Operation condition	I	←	←	←		
Link rod	Bending and damage	I	←	←	←		
	Installed portion looseness	I	←	←	←		
BRAKE SYSTEM							
Brake pedal	Play and reserve	M	←	←	←		
	Braking effect	I	←	←	←		
Parking brake	Pull margin	I	←	←	←		
	Braking effect	I	←	←	←		
	Rod and cable looseness and damage	I	←	←	←		
	Ratchet wear and damage					I	
Disk brake	Brake disk and pad wear and damage				M		



Suggest:

For more complete manuals. Please go to the home page.

<https://www.ebooklibonline.com>

If the above button click is invalid. Please download this document first, and then click the above link to download the complete manual.

Thank you so much for reading

Inspection Period		Every	1	3	6	12	Months
		Every	170	500	1000	2000	Hours
MATERIALS HANDLING EQUIPMENT							
Bucket	Bucket edge damage, wear	I	←	←	←		
	Bucket deformation, damage and crack	I	←	←	←		
	Bucket welded portion crack					I	
Lift arm and link	Lift arm and link deformation, damage and crack	I	←	←	←		
	Lift arm welded portion crack					I	
Bucket bracket	Stop lever, link and pin damage	I	←	←	←		
	Bucket bracket deformation, damage and crack	I	←	←	←		
	Bucket bracket welded portion crack					I	
Various kinds of attachments	Any abnormality and installed state of each part	I	←	←	←		
HYDRAULIC EQUIPMENT							
Cylinder	Cylinder installed portion looseness	T	←	←	←		
	Cylinder and piston rod damage	I	←	←	←		
	Rising speed, dumping speed	M	←	←	←		
	Cylinder operating condition, natural drop, natural forward tilt	M	←	←	←		
	Cylinder oil leak	I	←	←	←		
	Pin and cylinder bearing wear damage	I	←	←	←		
Oil pump	Oil leak, abnormal sound	I	←	←	←		
Hydraulic oil tank	Oil amount and dirt	I	←	←	←		
	Oil leak	I	←	←	←		
	Tank and strainer		C	←	←		
Operating pedal	Each connecting portion looseness	I	←	←	←		
	Pedal function	I	←	←	←		
	Pedal lock function	I	←	←	←		
Oil control valve	Oil leak	I	←	←	←		
	Safety valve function	I	←	←	←		
	Relief pressure measurement					M	
Hose, piping	Oil leak, looseness measurement	I	←	←	←		
ELECTRIC EQUIPMENT							
Ignition system	Distributor cap cracking	I	←	←	←		
	Damage of contact breaker arm and point	I	←	←	←		

Item		Inspection Period					Months
		Every	1	3	6	12	
		Every	170	500	1000	2000	Hours
Ignition system	Contact breaker point gap		M	←	←	←	
	Spark plug burning and gap		I	←	←	←	
	Ignition timing				M	←	
	Distributor side terminal burning		I	←	←	←	
	Wear and damage of distributor cap center terminal		I	←	←	←	
	Plug cord internal disconnection						I
Starter	Pinion gear meshing		I	←	←	←	
Charger	Charging function		I	←	←	←	
Electric wiring	Wire harness damage and connector looseness		I	←	←	←	
	Fuses		I	←	←	←	
Pre-heater	Glow plug heat coil breakage				I	←	
	Thermo-start plug function				I	←	
Battery	Specific gravity				M	←	
SAFETY DEVICE AND OTHERS							
Operator guard and side guard	Installed portion looseness		T	←	←	←	
	Deformation, crank, damage		I	←	←	←	
Direction indicator	Operation and installed state		I	←	←	←	
Alarm unit	Operation and installed state		I	←	←	←	
Lamp unit	Operation and installed state		I	←	←	←	
Reverse alarm	Operation and installed state		J	←	←	←	
Back mirror	Dirt and damage		I	←	←	←	
	Back reflection state		I	←	←	←	
Instruments	Each instrument operation		I	←	←	←	
Seat	Looseness, damage		I	←	←	←	
Seat Belt	Slackness, damage		I	←	←	←	
Body	Frame, cross member, etc. damage, crack					I	
	Bolt looseness					T	
Others	Each part grease up		L	←	←	←	

<https://www.ebooklibonline.com>

Hello dear friend!

Thank you very much for reading.

Enter the link into your browser.

The full manual is available for immediate download.

<https://www.ebooklibonline.com>