



Service Manual

Reelmaster® 5300-D

Preface

The purpose of this publication is to provide the service technician with information for troubleshooting, testing, and repair of major systems and components on the Reelmaster 5300-D

REFER TO THE REELMASTER 5300-D TRACTION UNIT AND CUTTING UNIT OPERATOR'S MANUALS FOR OPERATING, MAINTENANCE AND ADJUSTMENT INSTRUCTIONS. Space is provided in Chapter 2 of this book to insert the Operator's Manuals and Parts Catalogs for your machine. Replacement Operator's Manuals are available by sending complete Model and Serial Number of traction unit and cutting unit to:



This safety symbol means DANGER, WARNING, or CAUTION, PERSONAL SAFETY INSTRUCTION. When you see this symbol, carefully read the instructions that follow. Failure to obey the instructions may result in personal injury.

NOTE: A NOTE will give general information about the correct operation, maintenance, service, testing or repair of the machine.

IMPORTANT: The IMPORTANT notice will give important instructions which must be followed to prevent damage to systems or components on the machine.



Table Of Contents

Chapter 1 - Safety

Safety Instructions 1 - 1

Chapter 2 - Product Records and Manuals

Product Records 2 - 1
Equivalents and Conversions 2 - 2
Torque Specifications 2 - 3
Maintenance Interval Charts 2 - 4
Equipment Operation
and Service History Report 2 - 5

Chapter 3 - Mitsubishi S3L2 Diesel Engine

Introduction 3 - 2
Specifications 3 - 3
Special Tools 3 - 4
Adjustments 3 - 6
Repairs 3 - 7
MITSUBISHI SL-SERIES SERVICE MANUAL

Chapter 4 - Hydraulic System

Specifications 4 - 2
General Information 4 - 3
Hydraulic Schematic 4 - 6
Hydraulic Flow Diagrams 4 - 7
Special Tools 4 - 12
Troubleshooting 4 - 15
Testing 4 - 25
Adjustments 4 - 33
Transmission Repairs 4 - 35
Mowing Circuit Repairs 4 - 54
Hydraulic Reservoir and Filter 4 - 68

Chapter 5 - Electrical System

Wiring Schematics and Diagrams 5 - 3
Special Tools 5 - 5
Troubleshooting 5 - 7
Testing 5 - 18
Repairs 5 - 28

Chapter 6 - Differential Axle

Introduction 6 - 1
Torque Specifications 6 - 2
Repairs 6 - 3

Chapter 7 - Steering and Brakes

Introduction 7 - 2
Schematics 7 - 3
Specifications 7 - 4
Special Tools 7 - 4
Troubleshooting 7 - 5
Testing 7 - 7
Adjustments 7 - 9
Repairs 7 - 11

Chapter 8 - Cutting Units

Specifications 8 - 2
Special Tools 8 - 3
Troubleshooting 8 - 5
Set-up and Adjustments 8 - 7
Repairs 8 - 15

Chapter 9 - 4WD Rear Axle

Specifications 9 - 2
General Information 9 - 3
Adjustments 9 - 4
Repairs 9 - 5



Table of Contents

SAFETY INSTRUCTIONS	1	While Doing Maintenance, Troubleshooting,	
Before Operating	1	Testing, Adjustments or Repairs	3
While Operating	2		

Safety Instructions

The Reelmaster 5300-D was tested and certified by TORO for compliance with the B71.4-1990 specifications of the American National Standards Institute's safety standards for riding mowers when 65 lbs. of ballast is added to rear wheels and a rear weight kit, part no. 75-6690 is installed. Although hazard control and accident prevention partially are dependent upon the design and configuration of the machine, these factors are also dependent upon the awareness, concern, and proper training of the personnel involved in the operation, transport, maintenance, and storage of the machine.



CAUTION

Improper operation, maintenance, troubleshooting, testing, adjustments or repairs of the machine can result in injury or death. To reduce the potential for injury or death, comply with the following safety instructions.

<https://www.ebooklibonline.com>

Hello dear friend!

Thank you very much for reading.

Enter the link into your browser.

The full manual is available for immediate download.

<https://www.ebooklibonline.com>

8. Since diesel fuel is highly flammable, handle it carefully:

- A. Use an approved fuel container.
- B. Do not remove fuel tank cap while engine is hot or running.

C. Do not smoke while handling fuel.

D. Fill fuel tank outdoors and only to within an inch of the top of the tank, not the filler neck. Do not overfill.

E. Wipe up any spilled fuel.

While Operating

9. Sit on the seat when starting and operating the machine.

10. Before starting the engine:

- A. Engage the parking brake.
- B. Make sure traction pedal is in NEUTRAL and the ENABLE / DISABLE switch is in DISABLE.
- C. After engine is started, release parking brake and keep foot off traction pedal. Machine must not move. If movement is evident, the neutral return mechanism is adjusted incorrectly; therefore, shut engine off and adjust until machine does not move when traction pedal is released.

11. Seating capacity is one person. Therefore, never carry passengers.

12. Do not run engine in a confined area without adequate ventilation. Exhaust fumes are hazardous and could possibly be deadly.

13. Check interlock switches daily for proper operation. If a switch fails, replace it before operation the machine. The interlock system is for your protection, so do not bypass it. Replace all interlock switches every two years.

14. Using the machine demands attention. To prevent loss of control:

- A. Operate only in daylight or when there is good artificial light.
- B. Drive slowly.
- C. Watch for holes or other hidden hazards.
- D. Look behind machine before backing up.
- E. Do not drive close to a sand trap, ditch, creek or other hazard.
- F. Reduce speed when making sharp turns and turning on a hillside.

G. Avoid sudden stops and starts.

15. Traverse slopes carefully. Do not start or stop suddenly when traveling uphill.

16. Operator must be skilled and trained in how to drive on hillsides. Failure to use caution on slopes or hills may cause loss of control and vehicle to tip or roll possibly resulting in personal injury or death. On 4 wheel drive models, always use the seat belt and ROPS together.

17. If engine stalls or loses headway and cannot make it to the top of a slope, do not turn machine around. Always back slowly straight down the slope.

18. DON'T TAKE AN INJURY RISK! When a person or pet appears unexpectedly in or near the mowing area, STOP MOWING. Careless operation, combined with terrain angles, ricochets, or improperly positioned guards can lead to thrown object injuries. Do not resume mowing until area is cleared.

19. Do not touch engine, muffler or exhaust pipe while engine is running or soon after is stopped. These areas could be hot enough to cause burns.

20. If cutting unit strikes a solid object or vibrates abnormally, stop immediately, turn engine off, set parking brake and wait for all motion to stop. Inspect for damage. If reel or bedknife is damaged, repair or replace it before operating. Do not attempt to free blocked cutting unit by reversing its reel direction. Damage to the reel may result.

21. Before getting off the seat:

- A. Move traction pedal to neutral.
- B. Set parking brake.
- C. Disengage cutting units and wait for reels to stop.
- D. Stop engine and remove key from switch.
- E. Do not park on slopes unless wheels are chocked or blocked.

While Doing Maintenance, Troubleshooting, Testing, Adjustments or Repairs

22. Before servicing or making adjustments, stop the engine and remove the key from the ignition switch.
23. Make sure machine is in safe operating condition by keeping all nuts, bolts and screws tight.
24. Frequently inspect all hydraulic line connectors and fittings. Make sure all hydraulic hoses and lines are in good condition before applying pressure to the system.
25. Keep body and hands away from pin hole leaks or nozzles that eject high pressure hydraulic fluid. Use cardboard or paper to find hydraulic leaks. Hydraulic fluid escaping under pressure can penetrate the skin and cause injury. Fluid accidentally injected into the skin must be surgically removed within a few hours by a doctor or gangrene may occur.
26. Before disconnecting, or performing any work on the hydraulic system, lower the cutting units to the ground and stop the engine so all pressure is relieved.
27. Be sure you understand a service procedure before working on the machine. Unauthorized modifications to the machine may impair the function, safety and life of the machine. If major repairs are ever needed, or assistance is desired, contact your TORO Distributor.
28. To reduce potential fire hazard, keep engine area free of excessive grease, grass, leaves and dirt. Clean protective screen on front of engine frequently. Do not use flammable solvents for cleaning parts. Do not use diesel fuel, kerosene or gasoline.
29. If the engine must be running to perform an inspection or procedure, use extreme caution. Always use two people, with the operator at the controls able to see the person doing the inspection or procedure. Keep hands, feet, clothing, and body away from cutting units and other moving parts.
30. Do not overspeed the engine by changing governor setting.
31. Shut engine off before checking or adding oil to the engine crankcase.
32. Disconnect the cables from the battery before servicing the machine. If battery voltage is required for troubleshooting or test procedures, temporarily connect the battery.
33. Do not charge a frozen battery because it can explode and cause injury. Let the battery warm to 60° F (15.5° C) before connecting to a charger. Charge the battery in a well-ventilated place so that gases produced while charging can dissipate. Since the gases are explosive, keep open flame and electrical spark away from the battery; do not smoke. Nausea may result if the gases are inhaled. Unplug the charger from the electrical outlet before connecting or disconnecting the charger leads from the battery posts.
34. Wear safety glasses, goggles or a face shield to prevent possible eye injury when using compressed air for cleaning or drying components.
35. Failure to follow proper procedures when mounting a tire on a wheel or rim can produce an explosion which may result in serious injury. Do not attempt to mount a tire unless you have the proper equipment and experience to perform the job. Have it done by your Toro Distributor or a qualified tire service.
36. When changing attachments or performing other service, use the correct blocks and hoists. Always use jackstands to safely support the machine when it is raised by a jack or hoist.
37. Do not use your hand to prevent cutting unit reel from turning while servicing; this can result in personal injury. Use a 1-1/2 in. thick x 4 in. wide x 8 in. long piece of hardwood inserted into front of cutting unit between reel blades.
38. For optimum performance and safety, use genuine Toro replacement parts and accessories. Replacement parts and accessories made by other manufacturers may result in non-conformance with the safety standards, and the warranty may be voided.



Product Records and Manuals

Product Records
and Manuals

Table of Contents

PRODUCT RECORDS	1	TORQUE SPECIFICATIONS	3
EQUIVALENTS AND CONVERSIONS	2	Capscrew Markings and Torque Values - U.S. . . .	3
Decimal and Millimeter Equivalents	2	Capscrew Markings and Torque Values - Metric . . .	3
U.S. to Metric Conversions	2	MAINTENANCE INTERVAL CHART	4
		OPERATION AND SERVICE HISTORY REPORT	

Product Records

Record information about your Reelmaster 5300-D on the OPERATION AND SERVICE HISTORY REPORT form. Use this information when referring to your machine.

Insert Operator's Manuals and Parts Manuals for your Reelmaster 5300-D at the end of this section.

Equivalents and Conversions

Decimal and Millimeter Equivalents

Fractions	Decimals	mm	Fractions	Decimals	mm	
	1/64	0.015625	— 0.397	33/64	0.515625	— 13.097
1/32	—	0.03125	— 0.794	17/32	0.53125	— 13.494
	3/64	0.046875	— 1.191	35/64	0.546875	— 13.891
1/16	—	0.0625	— 1.588	9/16	0.5625	— 14.288
	5/64	0.078125	— 1.984	37/64	0.578125	— 14.684
	3/32	0.09375	— 2.381	19/32	0.59375	— 15.081
	7/64	0.109275	— 2.778	39/64	0.609375	— 15.478
1/8	—	0.1250	— 3.175	5/8	0.6250	— 15.875
	9/64	0.140625	— 3.572	41/64	0.640625	— 16.272
	5/32	0.15625	— 3.969	21/32	0.65625	— 16.669
	11/64	0.171875	— 4.366	43/64	0.671875	— 17.066
3/16	—	0.1875	— 4.762	11/16	0.6875	— 17.462
	13/64	0.203125	— 5.159	45/64	0.703125	— 17.859
	7/32	0.21875	— 5.556	23/32	0.71875	— 18.256
	15/64	0.234375	— 5.953	47/64	0.734375	— 18.653
1/4	—	0.2500	— 6.350	3/4	0.7500	— 19.050
	17/64	0.265625	— 6.747	49/64	0.765625	— 19.447
	9/32	0.28125	— 7.144	25/32	0.78125	— 19.844
	19/64	0.296875	— 7.541	51/64	0.796875	— 20.241
5/16	—	0.3125	— 7.938	13/16	0.8125	— 20.638
	21/64	0.328125	— 8.334	53/64	0.828125	— 21.034
	11/32	0.34375	— 8.731	27/32	0.84375	— 21.431
	23/64	0.359375	— 9.128	55/64	0.859375	— 21.828
3/8	—	0.3750	— 9.525	7/8	0.8750	— 22.225
	25/64	0.390625	— 9.922	57/64	0.890625	— 22.622
	13/32	0.40625	— 10.319	29/32	0.90625	— 23.019
	27/64	0.421875	— 10.716	59/64	0.921875	— 23.416
7/16	—	0.4375	— 11.112	15/16	0.9375	— 23.812
	29/64	0.453125	— 11.509	61/64	0.953125	— 24.209
	15/32	0.46875	— 11.906	31/32	0.96875	— 24.606
	31/64	0.484375	— 12.303	63/64	0.984375	— 25.003
1/2	—	0.5000	— 12.700	1	1.000	— 25.400
	1 mm = 0.03937 in.			0.001 in. = 0.0254 mm		

U.S to Metric Conversions



	To Convert	Into	Multiply By
Linear Measurement	Miles	Kilometers	1.609
	Yards	Meters	0.9144
	Feet	Meters	0.3048
	Feet	Centimeters	30.48
	Inches	Meters	0.0254
	Inches	Centimeters	2.54
	Inches	Millimeters	25.4
Area	Square Miles	Square Kilometers	2.59
	Square Feet	Square Meters	0.0929
	Square Inches	Square Centimeters	6.452
	Acre	Hectare	0.4047
Volume	Cubic Yards	Cubic Meters	0.7646
	Cubic Feet	Cubic Meters	0.02832
	Cubic Inches	Cubic Centimeters	16.39
Weight	Tons (Short)	Metric Tons	0.9078
	Pounds	Kilograms	0.4536
	Ounces (Avdp.)	Grams	28.3495
Pressure	Pounds/Sq. In.	Kilopascal	6.895
	Pounds/Sq. In.	Bar	0.069
Work	Foot-pounds	Newton-Meters	1.356
	Foot-pounds	Kilogram-Meters	0.1383
	Inch-pounds	Kilogram-Centimeters	1.152144
Liquid Volume	Quarts	Liters	0.9463
	Gallons	Liters	3.785
Liquid Flow	Gallons/Minute	Liters/Minute	3.785
Temperature	Fahrenheit	Celsius	1. Subtract 32°
			2. Multiply by 5/9

Torque Specifications

Use these torque values when specific torque values are not given. DO NOT use these values in place of

specified values. Torque values listed are for lubricated threads. Plated threads are considered to be lubricated.

Capscrew Markings and Torque Values - U.S. Customary

SAE Grade Number	5				8			
Capscrew Head Markings								
Capscrew Body Size	Capscrew Torque - Grade 5				Capscrew Torque - Grade 8			
	Cast Iron		Aluminum		Cast Iron		Aluminum	
	ft-lb	Nm	ft-lb	Nm	ft-lb	Nm	ft-lb	Nm
1/4-20 -28	7 9	9 12	6 7	8 9	11 13	15 18	9 10	12 14
5/16-18 -24	15 17	20 23	12 14	16 19	22 24	30 33	18 19	24 25
3/8-16 -24	30 30	40 40	20 25	25 35	40 45	55 60	30 35	40 45
7/16-14 -20	45 50	60 65	35 40	45 55	65 70	90 95	50 55	65 75
1/2-13 -20	70 75	95 100	55 60	75 80	95 110	130 150	75 90	100 120
9/16-12 -18	100 110	135 150	80 85	110 115	140 155	190 210	110 125	150 170
5/8-11 -18	135 155	180 210	110 120	150 160	190 215	255 290	150 170	205 230
3/4-10 -16	240 270	325 365	190 210	255 285	340 380	460 515	270 300	365 410
7/8-9 -14	360 390	490 530	280 310	380 420	550 610	745 825	440 490	600 660
1-8 -14	530 590	720 800	420 480	570 650	820 890	1100 1200	660 710	890 960

Product Records and Manuals

Capscrew Markings and Torque Values – Metric

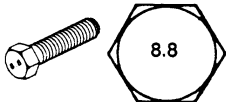
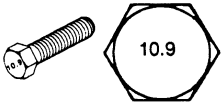
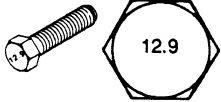
Commercial Steel Class	8.8				10.9				12.9			
Capscrew Head Markings												
Thread Diameter mm	Capscrew Torque - Class 8.8				Capscrew Torque - Class 10.9				Capscrew Torque - Class 12.9			
	Cast Iron		Aluminum		Cast Iron		Aluminum		Cast Iron		Aluminum	
	ft-lb	Nm	ft-lb	Nm	ft-lb	Nm	ft-lb	Nm	ft-lb	Nm	ft-lb	Nm
6	5	9	4	7	9	14	7	11	9	14	7	11
7	9	14	7	11	14	18	11	14	18	23	14	18
8	18	25	14	18	23	32	18	25	27	36	21	28
10	30	40	25	30	45	60	35	45	50	70	40	55
12	55	70	40	55	75	105	60	80	95	125	75	100
14	85	115	65	90	120	160	95	125	145	195	110	150
16	130	180	100	140	175	240	135	190	210	290	165	220
18	170	230	135	180	240	320	185	250	290	400	230	310

Maintenance Interval Chart

REELMASTER 5100-D/5300-D QUICK REFERENCE AID

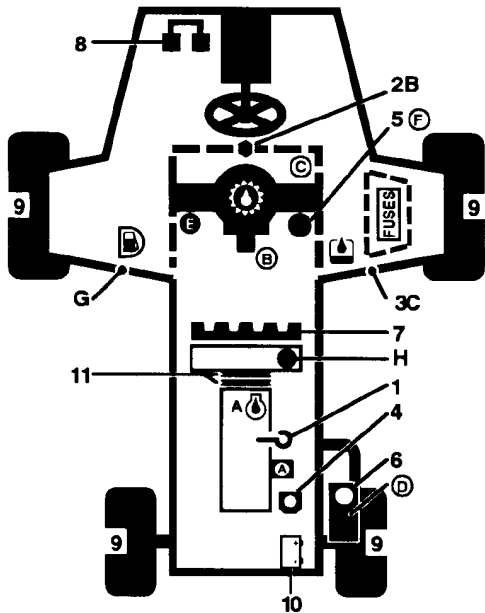

CHECK/SERVICE (daily)

- | | |
|------------------------------|----------------------------------|
| 1. OIL LEVEL, ENGINE | 7. RADIATOR SCREEN |
| 2. OIL LEVEL, TRANSMISSION | 8. BRAKE FUNCTION |
| 3. OIL LEVEL, HYDRAULIC TANK | 9. TIRE PRESSURE |
| 4. COOLANT LEVEL, RADIATOR | 10. BATTERY |
| 5. FUEL /WATER SEPARATOR | 11. BELTS (FAN, ALT.) |
| 6. PRECLEANER - AIR CLEANER | GREASING - SEE OPERATOR'S MANUAL |

FLUID SPECIFICATIONS/CHANGE INTERVALS

SEE OPERATOR'S MANUAL FOR INITIAL CHANGES.	FLUID TYPE	CAPACITY	CHANGE INTERVAL		FILTER PART NO.
			FLUID	FILTER	
A. ENGINE OIL	SAE 10W-30CD	3.9 QTS. † 4.0 QTS. ††	50 HRS.	100 HRS.	67-4330 † 93-4295 ††
B. TRANSMISSION OIL	MOBIL 424	5 QTS.*	800 HRS.	800 HRS.	75-1330
C. HYD. CIRCUIT OIL	MOBIL 424	8.5 GALS.*	800 HRS.	SEE INDICATOR	75-1310
D. AIR CLEANER				400 HRS.	27-7110
E. FUEL PUMP				400 HRS.	43-2550
F. WATER SEPARATOR				400 HRS.	63-8300
G. FUEL TANK	NO. 2-Diesel	10 GALS.	Drain and flush, 2 yrs.		
H. COOLANT	50/50 Ethylene glycol/water	7 QTS. † 9.6 QTS. ††	Drain and flush, 2 yrs.		

* INCLUDING FILTER

† REELMASTER 5100-D
†† REELMASTER 5300-D

93-3601

REELMASTER® 223-D, 5100-D, and 5300-D Maintenance Schedule

Minimum Recommended Maintenance Intervals:

Maintenance Procedure	Maintenance Interval & Service				
Check Battery Fluid Level Check Battery Cable Connections Lubricate All Grease Fittings Change Engine Oil Inspect Air Filter, Dust Cup, and Baffle	Every 50hrs	Every 100hrs	Every 200hrs	Every 400hrs	Every 800hrs
† Check Fan and Alternator Belt Tension					
‡ Replace Engine Oil Filter					<i>B Level Service</i>
Inspect Cooling System Hoses					
Drain Moisture-Hyd. Tank					
Drain Moisture-Fuel Tank					
Check Reel Bearing Preload Adjustment					<i>C Level</i>
† Torque Wheel Lug Nuts					
Service Air Filter					
Replace Electric Fuel Pump Filter					
Replace Fuel/Water Separator Filter					
Inspect Traction Linkage Movement					
‡ Torque Head and Adjust Valves					<i>D Level</i>
‡ Check Engine RPM (idle and full throttle)					
Change Hydraulic Fluid					
Change Transmission Fluid					
† Replace Transmission Filter					
Check Rear Wheel Toe-in					
Rear Axle Service					
- pack Rear Wheel Bearings (2WD)					
- change Rear Axle Lubricant (4WD)					<i>E Level Service</i>
† Initial break in at 10 hours					
‡ Initial break in at 50 hours					
Replace Moving Hoses Replace Safety Switches Coolant System - Flush/Replace Fluid Fuel Tank - Drain/Flush Hydraulic Tank - Drain/Flush					Annual Recommendations: <i>Items listed are recommended every 1600 hours or 2 years whichever occurs first.</i>

(See Operator's and Service Manual for specifications and procedures)

REELMASTER® 223-D, 5100-D and 5300-D Daily Maintenance Check List

Unit Designation: _____

Daily Maintenance:(duplicate this page for routine use)

TORO ID#: _____ - _____

Maintenance Check Item	Daily Maintenance Check For Week Of						
	MON _____ HRS	TUES _____ HRS	WED _____ HRS	THURS _____ HRS	FRI _____ HRS	SAT _____ HRS	SUN _____ HRS
✓ Safety Interlock Operation							
✓ Brake Operation							
✓ Engine Oil & Fuel Level							
✓ Cooling System Fluid Level							
Drain Water/Fuel Separator							
✓ Air Filter/Pre-Cleaner Condition							
✓ Radiator & Screen for Debris							
✓ Unusual Engine Noises ¹							
✓ Unusual Operating Noises							
✓ Transmission Oil Level							
✓ Hydraulic System Oil Level							
✓ Hydraulic Filter Indicator ²							
✓ Hydraulic Hoses for Damage							
✓ Fluid Leaks							
✓ Tire Pressure							
✓ Instrument Operation							
✓ Reel-to-Bedknife Adjustment							
✓ Height-of-Cut Adjustment							
✓ Cutting Units Shear Pin							
Lubricate All Grease Fittings ³							
Touch-up damaged paint							

¹ = Check glow plugs and injector nozzles, if hard starting, excess smoke, or rough running is noted.

² = Check with engine running and oil at operating temperature.

³ = Immediately after every washing, regardless of the interval listed.

Notation for areas of concern: Inspection performed by: _____

Item	Date	Information
1		
2		
3		
4		
5		
6		
7		

(See Operator's and Service Manual for specifications and procedures)

REELMASTER® 223-D, 5100-D, and 5300-D Supervisor Maintenance Work Order

Date: _____

(duplicate this page for routine use)

Unit Designation:	TORO I.D. #: _____ - _____
Hours:	Service to perform (circle): A B C D E Other
Technician:	

Remarks:

A -Service (every 50 hours)

- Check Battery Fluid Level
- Check Battery Cable Connections
- Lubricate All Grease Fittings
- Change Engine Oil
- Inspect Air Filter, Dust Cup, and Baffle
- _____
- _____
- _____
- _____

B -Service (every 100 hours)

- Check Fan and Alternator Belt Tension
- Replace Engine Oil Filter
- Inspect Cooling System Hoses
- A-Service** required
- _____
- _____
- _____
- _____

C -Service (every 200 hours)

- Drain Moisture-Hyd. Tank
- Drain Moisture-Fuel Tank
- Check Reel Bearing Preload
- Torque Wheel Lug Nuts
- A and B Service** required
- _____
- _____
- _____
- _____

D -Service (every 400 hours)

- Service Air Filter
- Replace Electric Fuel Pump Filter
- Replace Fuel/WaterSeparator Filter
- Inspect Traction Linkage Movement
- Torque Head and Adjust Valves
- Check Engine RPM (idle and full throttle)
- A, B, and C Service** required
- _____
- _____

E -Service (every 800 hours)

- Change Hydraulic Fluid
- Change Transmission Fluid
- Replace Transmission Filter
- Check Rear Wheel Toe-in
- Pack Rear Wheel Brgs/Change 4WD Oil
- A, B, C, and D Service** required
- _____
- _____
- _____

Other - Annual Service and Specials

- Replace Moving Hoses
- Replace Safety Switches
- Coolant System - Flush/Replace Fluid
- Fuel Tank - Drain/Flush
- Hydraulic Tank - Drain/Flush
- _____
- _____
- _____
- _____

(See Operator's and Service Manual for specifications and procedures)



Table of Contents

INTRODUCTION	2	REPAIRS	7
SPECIFICATIONS	3	Cooling Fan Belt and	
SPECIAL TOOLS	4	Alternator Belt Replacement	7
ADJUSTMENTS	6	Bleeding the Fuel System	8
Engine Speed Adjustments	6	Bleeding Air From the Injectors	9
Throttle Linkage Adjustment	6	Removing and Installing the Fuel Tank	10
		Replacing and/or Adjusting	
		Engine Stop (ETR) Solenoid	11
		Removing the Engine	12
		Installing the Engine	13

Engine

Introduction

This chapter gives information about specifications, maintenance, troubleshooting, testing and repair of the diesel engine used in the Reelmaster[®] 5300-D mower.

Most repairs and adjustments require tools which are commonly available in many service shops. Special tools are described in the Special Tools section. The use of some specialized test equipment is explained, however, the cost of the test equipment and the specialized nature of some repairs may dictate that the work be done at a qualified diesel engine repair facility.

The engine used in the Reelmaster[®] 5300-D mower is manufactured by Mitsubishi Heavy Industries Limited. Service and repair parts for Mitsubishi engines are supplied through TORO Distributors. Repair parts may be ordered by TORO Part Number. If no parts list is available be sure to provide your dealer or distributor with the TORO Model Number and Serial Number.

Specifications

Item	Specification
Make/Designation	Mitsubishi S3L2, 4 cycle, liquid cooled, vertical overhead valve diesel
Combustion Chamber	Swirl chamber type
Number of Cylinders	3
Bore x Stroke	78 x 92 mm
Total Displacement	1.318 Liter
Compression Ratio	3:1
Firing Order	1 - 3 - 2
Dry Weight (approximate)	125 kg (276 lb.)
Fuel	Diesel
Fuel Injection Pump	Bosch type ND-PFR-NC
Governor	Mechanical centrifugal weight type
Fuel Injector Nozzle	Nippon Denso throttle type
Fuel Injection Pressure	(140 kg/cm ²) 1990 psi
Lubrication System	Forced lubrication
Oil Pump	Gear type
Oil Filter	Paper element filter (full flow type)
Crankcase Oil Capacity: including filter of 0.5 liter (0.6 qt.) capacity	4.1 Liter (3.9 qt.)
Cooling System	Forced circulation, water cooling
Water Pump	Centrifugal type
Cooling System Capacity Total System (approximate)	10.1 Liter (9.6 qt.)
Starter	Solenoid shift type 1.6 kW (12 volt)
Alternator	AC type 12 volt 50A
Glow Plug	Quick heat sheathed type

Engine

Special Tools

Order special tools from *TORO SPECIAL TOOLS AND APPLICATIONS GUIDE (Commercial Products)*. Some tools may be available from a local supplier.

Filter Cleaner

Filter cleaner (Fig. 1). Mix with water and use solution to wash the Donaldson air cleaner element.

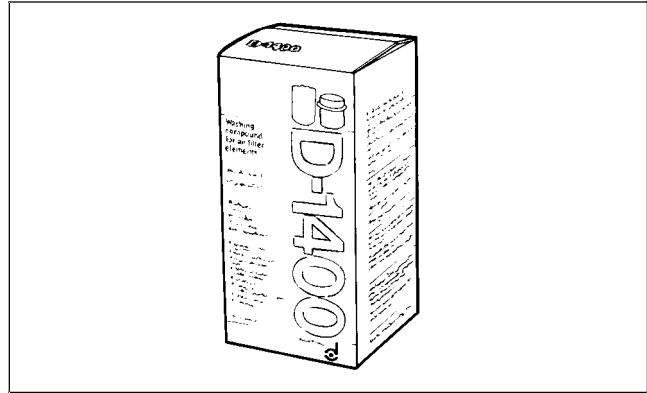

Figure 1

Diesel Engine Compression Test Kit

Diesel engine compression test kit (Fig. 2). 0-1000 PSI Gauge allows testing of diesel engines to check general operating condition of engine. Includes case, gauge with hose, glow plug hole adapters and instructions.

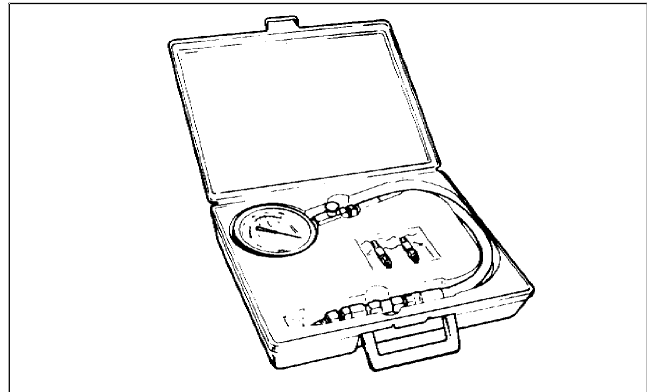

Figure 2

Piston Pin Tool

Piston pin tool (Fig. 3) is used to remove and install the wrist pin without distorting the piston. Includes an adapter for use with Mitsubishi and most other engines.

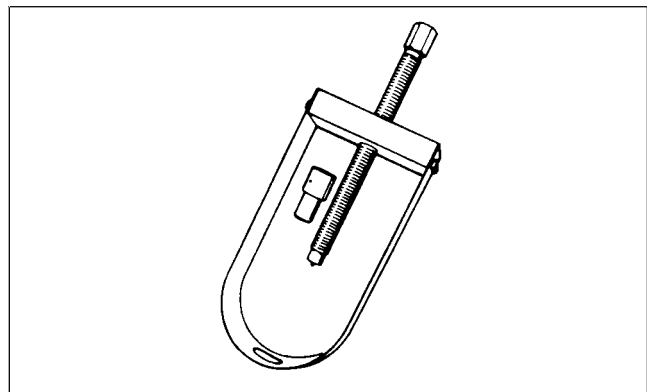

Figure 3

Nozzle Tester

Nozzle tester (Fig. 4). Tests condition and opening pressure of fuel injector nozzles.

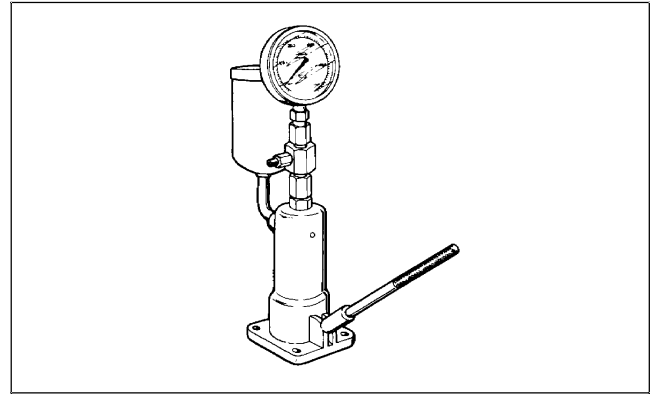

Figure 4

Nozzle Tester Adapter

Nozzle tester adapter (Fig.5) is required to test the fuel injection nozzles.

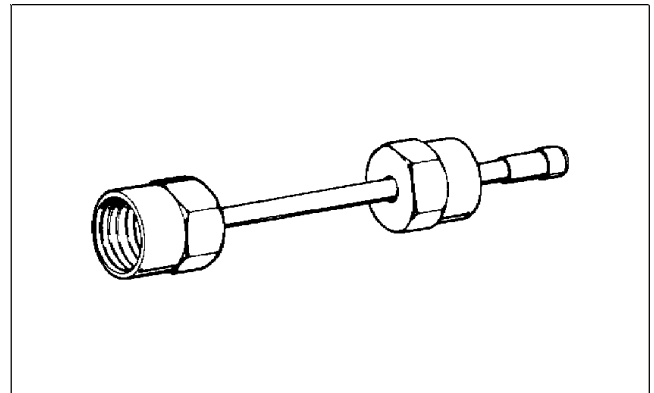

Figure 5

Engine

Adjustments

Engine Speed Adjustments

Adjustments to the engine speed settings are not normally necessary unless the throttle linkage, injection pump, or governor mechanism have been repaired, rebuilt, replaced or are not operating correctly.

The high speed set bolt has been set properly and sealed at the factory. Never tamper with the seal unless necessary.

Idle Speed (no load):	1700 $^{+50}_{-0}$ rpm
Maximum engine speed (no load):	3200 $^{+50}_{-0}$ rpm

See Engine Service Manual for Engine Speed Adjustment procedure.

Throttle Linkage Adjustment

1. Push the throttle lever forward until it stops against the slot in the seat base (Fig. 6).

2. Loosen the throttle cable connector on the lever arm at the injection pump (Fig. 7).

3. Hold the injection pump lever arm against the high idle stop and tighten the cable connector.

NOTE: When tightened, the cable connector must be free to swivel.

4. Make sure the throttle cable conduit does not interfere with the full range of motion of the throttle lever or governor lever.

5. Tighten locknut on throttle lever pivot to 40 - 55 in-lb (Fig. 6). The maximum force required to operate the throttle lever should be 20 lb.

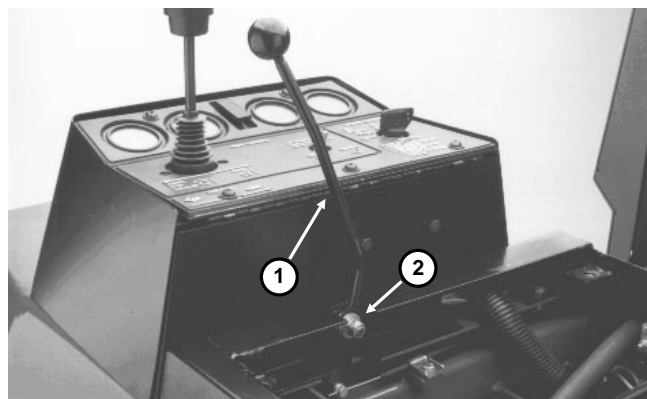

Figure 6

1. Throttle lever

2. Locknut



Figure 7

1. Injection pump lever arm

Repairs

Fan Belt and Alternator Belt Replacement

1. Put machine on a level surface, engage parking brake, stop engine and remove key from ignition switch. Open hood.

2. Loosen locknut on belt tensioner lever (Fig. 8). If replacing alternator belt, loosen bolt securing alternator brace to engine and bolt securing alternator to brace (Fig. 9).

3. Remove three capscrews securing transmission drive shaft coupler to engine crankshaft pulley (Fig. 10). Do not disconnect drive shaft from transmission.

4. Move drive shaft out of the way so the belt(s) can be removed.

5. Install new belt(s).

6. Connect drive shaft coupler to engine crankshaft pulley with two capscrews and lockwashers.

7. Adjust belt tension:

Alternator belt: Insert pry bar between alternator and engine and carefully pry alternator out until proper tension is achieved. Belt should deflect $\frac{3}{8}$ to $\frac{1}{2}$ in. when 22 lb. of force is applied to belt midway between crankshaft pulley and alternator pulley. Tighten alternator and brace bolts to secure adjustment.

Cooling fan belt: Apply 5 - 10 lb. of force at end of lever. Tighten lock nut to secure adjustment.

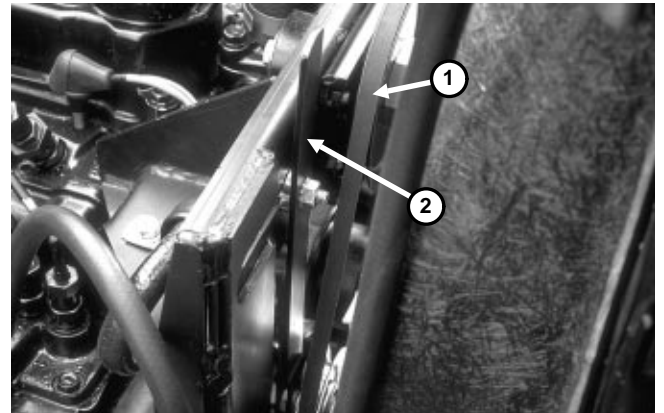

Figure 8

1. Fan belt

2. Tensioner lever

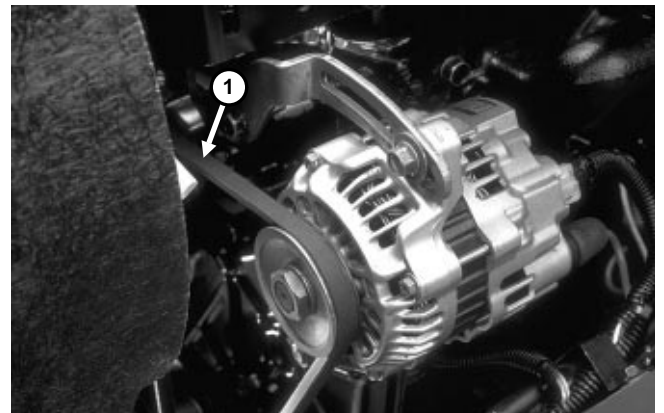

Figure 9

1. Alternator belt

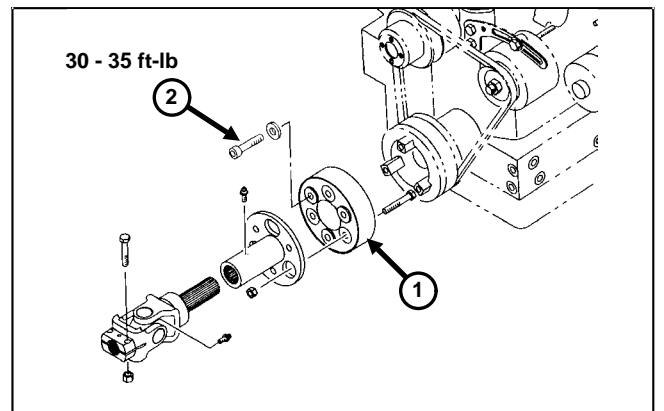

Figure 10

1. Drive shaft coupling

2. Capscrew & lockwasher (3)

Bleeding the Fuel System

1. Stop the engine and engage the parking brake. Open the hood.

2. Loosen the air bleed screw on the fuel filter / water separator (Fig. 11).

3. Turn the ignition key switch to the ON position. The electric fuel pump will begin to operate and force fuel out around the screw loosened in step 2. Fuel will fill the filter bowl and then flow out around the screw. When a solid stream of fuel flows out around the screw, tighten the screw and turn the key switch OFF.

4. Open the air vent screw on the fuel injection pump (Fig. 12).

5. Turn the ignition key switch to the ON position. The electric fuel pump will begin to operate and force fuel out around the injection pump air vent screw. When a solid stream of fuel flows out around the screw, tighten the screw and turn the key switch OFF.

NOTE: Normally the engine should start after this procedure. If the engine does not start, air may be trapped between the injection pump and injectors (See Bleeding Air From the Injectors).

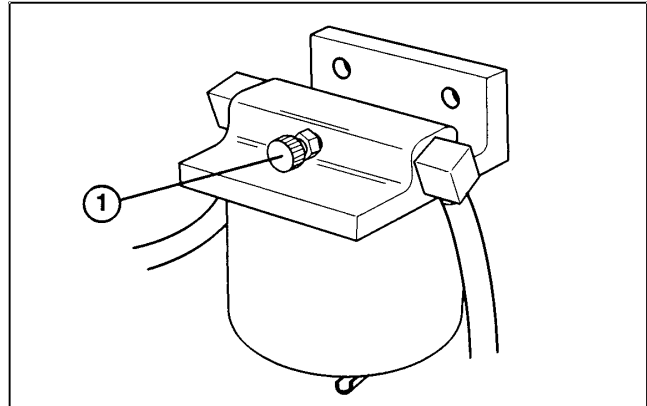

Figure 11

1. Bleed screw

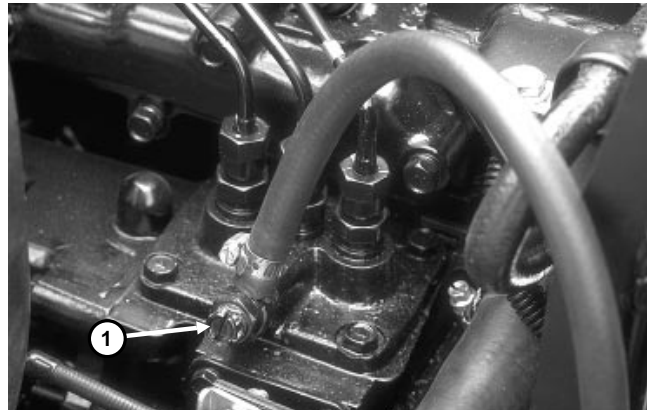

Figure 12

1. Fuel injection pump air vent screw

Bleeding Air From the Injectors

This procedure should only be used if the fuel system has been purged of air. (See Bleeding the Fuel System in this section of the book.)

1. Loosen the pipe connection at the number one nozzle and holder assembly on the cylinder head (Fig. 13).

2. Move the throttle control to the FAST position.

3. Turn the ignition key to the START position to crank the engine and pump fuel to the nozzles. Turn the ignition key to the OFF position when a steady stream of fuel flows out of the loose pipe connection.

4. Tighten the pipe connector.

5. Repeat steps 1 - 4 for the No. 2 and No. 3 injector nozzle and holder.



Figure 13

1. Fuel injector nozzle and holder (3)

Removing and Installing the Fuel Tank

1. Put machine on a level surface, lower the cutting units, stop the engine, engage the parking brakes and remove the key from the ignition switch.
2. Open drain fitting on bottom of fuel tank and drain fuel into a suitable container (Fig. 14).
3. Remove six capscrews securing the fender to the frame and remove the fender.
4. Disconnect fuel lines from fittings on top of fuel tank.
5. Disconnect electrical wire from fuel gauge sender.
6. Remove three capscrews, flat washers and lock-washers securing fuel tank to frame and remove fuel tank.
7. Reverse steps 2 - 6 to install the fuel tank and tank base. When installing the tank to the frame, tighten the screws to a torque of 30 - 60 in-lb (Fig. 15). Do not overtighten.

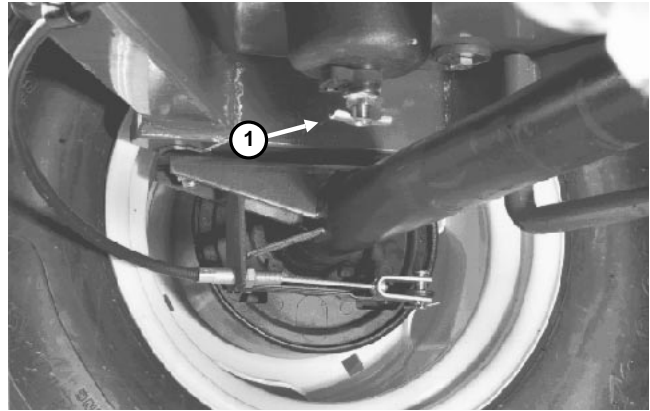

Figure 14

1. Fuel tank drain fitting

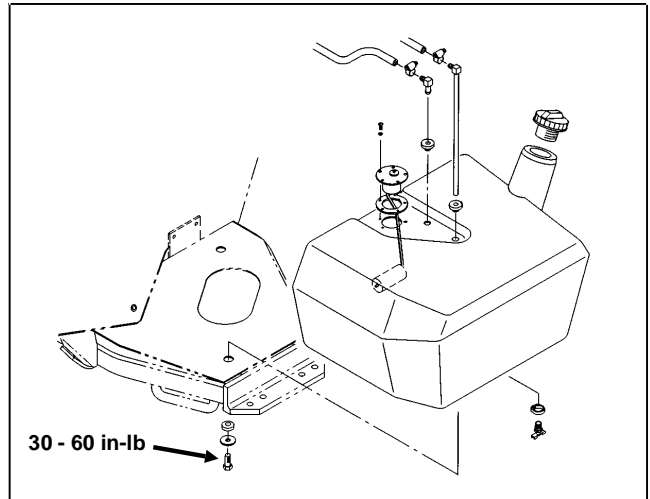

Figure 15

Replacing and/or Adjusting Engine Stop (ETR) Solenoid

See Chapter 5 - Electrical System for information about testing the engine stop solenoid.

An improperly adjusted stop solenoid can result in failure of the engine to stop when the key switch is turned off or could cause injection pump damage or malfunction.

Removing the Stop Solenoid

1. Stop the engine. If the engine will not stop when the ignition key switch is turned off, manually push the stop lever toward the rear of the machine until the engine stops.
2. Disconnect the solenoid electrical connector.
3. Loosen the nut securing the solenoid to the engine and unscrew the solenoid.
4. If you will be installing a new solenoid, remove the gasket and nut from the old solenoid and install them on the new solenoid. Thread the nut completely on the new solenoid.

Installing and/or Adjusting the Stop Solenoid

1. Remove the governor tie rod cover (Fig. 16).
2. Apply thread sealant to the solenoid threads.
3. Thread the solenoid into the engine.
4. Thread the solenoid into the engine while moving the tie rod back and forth (Fig. 17). Stop screwing the solenoid into the engine when there is no free play in the tie rod.
5. Turn the solenoid outward (counterclockwise) 1/4 to 1/2 turn. There should be a small amount of free play in the injector pump control rack 0.01 - 0.03 in. (0.3 - 0.7 mm).

IMPORTANT: No free play in the control rack with the solenoid de-energized (plunger out) may cause injection pump damage or malfunction. Excess free play 0.04 in. (1 mm) or more will prevent the engine from stopping when the solenoid is de-energized.

6. Hold the solenoid body to prevent it from turning and tighten the nut against the engine to secure the adjustment. Do not over tighten the nut. If the nut is over tightened, the solenoid may become distorted and will not operate correctly.

7. Connect the solenoid electrical connector.
8. Install the governor tie rod cover.

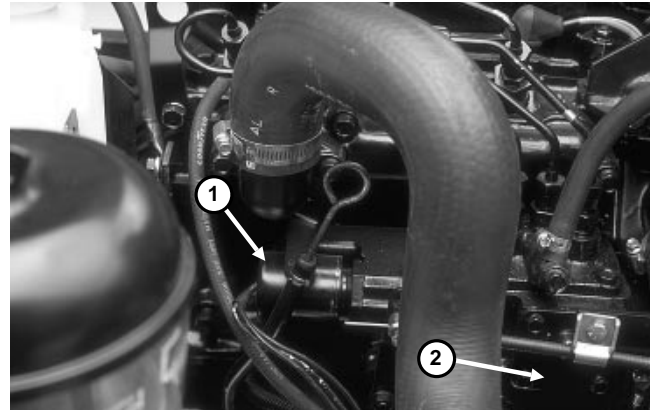

Figure 16

1. Fuel stop (ETR) solenoid
2. Governor tie rod cover

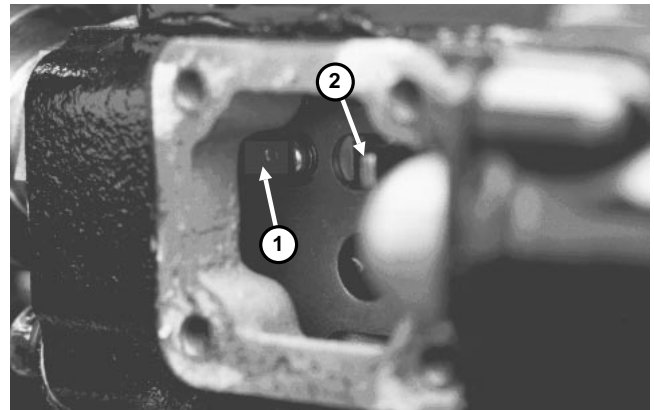

Figure 17

1. Solenoid plunger
2. Tie rod



Suggest:

For more complete manuals. Please go to the home page.

<https://www.ebooklibonline.com>

If the above button click is invalid. Please download this document first, and then click the above link to download the complete manual.

Thank you so much for reading

Removing and Installing the Engine

Removing the Engine



Figure 18

1. Put machine on a level surface, lower the cutting units, stop the engine, engage the parking brakes and remove key from ignition switch. Allow engine and radiator to cool.

2. Open hood. Disconnect hood stop cable from frame. Lower hood. Remove left and right hinge plates. Lift hood off chassis.

3. Disconnect positive (+) and negative (-) battery cables from battery. Loosen battery securing bolt and remove battery.

4. Remove rear lift arm down pressure springs (see Chapter 8 - Cutting Units).

5. Open radiator cap. Put a drain pan under left side of radiator. Open radiator drain valve and allow coolant to drain into drain pan.

 **CAUTION**

DO NOT open radiator cap or drain coolant if engine or radiator is hot. Pressurized, hot coolant can escape and cause burns.

Ethylene-glycol antifreeze is poisonous. Dispose of it properly or store in a properly labeled container away from children or pets.

6. Loosen hose clamps and disconnect upper and lower radiator hoses from engine and radiator. Lift coolant expansion tank off of bracket.

7. Remove plug from right side cylinder block to drain coolant from engine.

8. Loosen hose clamps and disconnect air intake hose from engine and air cleaner.

9. Remove muffler. Keep muffler bracket on engine.

10. Loosen hose clamp and remove fuel hose from injector pump. Plug end of fuel line to prevent fuel leakage. Loosen hose clamp and remove fuel return hose from rear fuel injector on engine.

11. Disconnect and tag wires that attach to engine or engine components:

- Alternator
- Starter motor and solenoid
- Ground cables
- Oil pressure switch
- Temperature gauge sender
- Thermoswitch
- Engine stop solenoid
- Glow indicator

12. Remove two (2) capscrews and lockwashers to disconnect drive shaft coupler from engine crankshaft pulley.

13. Remove four (4) capscrews, washers and locknuts to remove fan shroud from radiator.

14. Loosen cap screw and nut to disconnect throttle cable from governor lever on engine. Loosen clamp and remove throttle cable and from fan bracket.

15. Remove locknut, flat washer, bolt and rebound washer securing engine to each of four (4) rubber engine mounts.

16. Attach a short section of chain between lifting holes in fan bracket and muffler bracket. Connect hoist or block and tackle chain at center of short section of chain. One person should operate hoist or block and tackle and the other person should help guide engine out of chassis. Remove engine from chassis. Be careful when removing engine to prevent damage to engine, radiator, fan or other parts. Mount engine in an engine rebuilding stand.

17. Remove fan, brackets and accessories from engine as necessary. Drain oil from engine and remove engine oil filter.

Installing the Engine

1. To install the engine, perform steps 2 - 17 of Removing the Engine in reverse order.

2. Install a new engine oil filter. Fill engine with the correct oil. Fill the cooling system with a 50/50 solution

of ethylene glycol antifreeze and clean, soft water. Check for oil and coolant leaks and repair as necessary.

3. Adjust throttle linkage (See Throttle Linkage Adjustment in the Adjustments section of this chapter).

<https://www.ebooklibonline.com>

Hello dear friend!

Thank you very much for reading.

Enter the link into your browser.

The full manual is available for immediate download.

<https://www.ebooklibonline.com>