



Service Manual

Groundsmaster[®] 4500-D/4700-D



This safety symbol means **DANGER, WARNING, or CAUTION, PERSONAL SAFETY INSTRUCTION**. When you see this symbol, carefully read the instructions that follow. Failure to obey the instructions may result in personal injury.

NOTE: A **NOTE** will give general information about the correct operation, maintenance, service, testing, or repair of the machine.

IMPORTANT: The **IMPORTANT** notice will give important instructions which must be followed to prevent damage to systems or components on the machine.



Table Of Contents

Chapter 1 - Safety

General Safety Instructions	1 - 2
Jacking Instructions	1 - 4
Safety and Instruction Decals	1 - 5

Chapter 2 - Product Records and Maintenance

Product Records	2 - 1
Maintenance	2 - 1
Equivalents and Conversions	2 - 2
Torque Specifications	2 - 3

Chapter 3 - Kubota Diesel Engine

General Information	3 - 2
Specifications	3 - 3
Adjustments	3 - 4
Service and Repairs	3 - 5
KUBOTA WORKSHOP MANUAL, DIESEL ENGINE, V2003-T SERIES	

Chapter 4 - Hydraulic System

Specifications	4 - 2
General Information	4 - 3
Hydraulic Schematics	4 - 6
Hydraulic Flow Diagrams	4 - 8
Special Tools	4 - 20
Troubleshooting	4 - 22
Testing	4 - 25
Service and Repairs	4 - 52

Chapter 5 - Electrical System

Electrical Schematics and Electrical Harness and Connectors Drawings	5 - 2
Special Tools	5 - 2
Troubleshooting	5 - 3
Electrical System Quick Checks	5 - 6
Component Testing	5 - 7
Service and Repairs	5 - 27

Chapter 6 - Axles, Planetaries, and Brakes

Specifications	6 - 2
Adjustments	6 - 3
Service and Repairs	6 - 4

Chapter 7 - Chassis

General Information	7 - 1
Service and Repairs	7 - 2

Chapter 8 - Cutting Units

Specifications	8 - 2
Troubleshooting	8 - 3
Special Tools	8 - 4
Adjustments	8 - 5
Service and Repairs	8 - 8

Chapter 9 - Electrical Diagrams

Electrical Schematics	9 - 3
Circuit Diagrams	9 - 9
Wire Harness Drawings	9 - 14

Safety

Product Records
and Maintenance

Kubota
Diesel Engine

Hydraulic
System

Electrical
System

Axles, Planetaries,
and Brakes

Chassis

Cutting Units

Electrical
Diagrams



Table of Contents

GENERAL SAFETY INSTRUCTIONS	2	JACKING INSTRUCTIONS	4
Before Operating	2	SAFETY AND INSTRUCTION DECALS	5
While Operating	2		
Maintenance and Service	3		

<https://www.ebooklibonline.com>

Hello dear friend!

Thank you very much for reading.

Enter the link into your browser.

The full manual is available for immediate download.

<https://www.ebooklibonline.com>

General Safety Instructions

The GROUNDSMASTER 4500-D/4700-D was tested and certified by TORO for compliance with the B71.4-1999 specifications of the American National Standards Institute. Although hazard control and accident prevention partially are dependent upon the design and configuration of the machine, these factors are also dependent upon the awareness, concern, and proper training of the personnel involved in the operation, transport, maintenance, and storage of the machine. Improper use or maintenance of the machine can result in injury

or death. To reduce the potential for injury or death, comply with the following safety instructions.



While Operating

1. Sit on the seat when starting and operating the machine.
2. Before starting the engine:
 - A. Engage the parking brake.
 - B. Make sure traction pedal is in neutral and the PTO switch is OFF (disengaged).
 - C. After engine is started, release parking brake and keep foot off traction pedal. Machine must not move. If movement is evident, the traction pedal linkage is adjusted incorrectly; therefore, shut engine off and adjust traction pedal linkage until machine does not move when traction pedal is released.
3. Do not run engine in a confined area without adequate ventilation. Exhaust fumes are hazardous and could possibly be deadly.
4. Do not touch engine, muffler or exhaust pipe while engine is running or soon after it is stopped. These areas could be hot enough to cause burns.
5. Before getting off the seat:
 - A. Ensure that traction pedal is in neutral.
 - B. Set parking brake.
 - C. Disengage cutting units and wait for blades to stop.
 - D. Stop engine and remove key from switch.
 - E. Toro recommends that anytime the machine is parked (short or long term), the cutting units should be lowered to the ground. This relieves pressure from the lift circuit and eliminates the risk of cutting units accidentally lowering to the ground.
 - F. Do not park on slopes unless wheels are chocked or blocked.

Maintenance and Service

1. Before servicing or making adjustments, lower decks, stop engine, set parking brake, and remove key from the switch.
2. Make sure machine is in safe operating condition by keeping all nuts, bolts and screws tight.
3. Never store the machine or fuel container inside where there is an open flame, such as near a water heater or furnace.
4. Make sure all hydraulic line connectors are tight, and all hydraulic hoses and lines are in good condition before applying pressure to the system.
5. Keep body and hands away from pin hole leaks in hydraulic lines that eject high pressure hydraulic fluid. Use cardboard or paper to find hydraulic leaks. Hydraulic fluid escaping under pressure can penetrate skin and cause injury. Fluid accidentally injected into the skin must be surgically removed within a few hours by a doctor familiar with this form of injury or gangrene may result.
6. Before disconnecting or performing any work on the hydraulic system, all pressure in system must be relieved by stopping engine and lowering cutting units to the ground.
7. If major repairs are ever needed or assistance is desired, contact an Authorized Toro Distributor.
8. To reduce potential fire hazard, keep engine area free of excessive grease, grass, leaves and dirt. Clean protective screen on machine frequently.
9. If engine must be running to perform maintenance or an adjustment, keep hands, feet, clothing, and other parts of the body away from cutting units and other moving parts. Keep bystanders away.
10. Do not overspeed the engine by changing governor setting. To assure safety and accuracy, check maximum engine speed.
11. Shut engine off before checking or adding oil to the crankcase.
12. Disconnect battery before servicing the machine. Disconnect negative battery cable first and positive cable last. If battery voltage is required for troubleshooting or test procedures, temporarily connect the battery. Reconnect positive cable first and negative cable last.
13. Battery acid is poisonous and can cause burns. Avoid contact with skin, eyes, and clothing. Protect your face, eyes, and clothing when working with a battery.
14. Battery gases can explode. Keep cigarettes, sparks, and flames away from the battery.
15. At the time of manufacture, the machine conformed to the safety standards for riding mowers. To assure optimum performance and continued safety certification of the machine, use genuine Toro replacement parts and accessories. Replacement parts and accessories made by other manufacturers may result in non-conformance with the safety standards, and the warranty may be voided.
16. When changing attachments, tires, or performing other service, use correct blocks, hoists, and jacks. Make sure machine is parked on a solid level floor such as a concrete floor. Prior to raising the machine, remove any attachments that may interfere with the safe and proper raising of the machine. Always chock or block wheels. Use jack stands or solid wood blocks to support the raised machine. If the machine is not properly supported by blocks or jack stands, the machine may move or fall, which may result in personal injury (see Jacking Instructions).

Jacking Instructions



CAUTION

When changing attachments, tires, or performing other service, use correct blocks, hoists, and jacks. Make sure machine is parked on a solid level surface such as a concrete floor. Prior to raising machine, remove any attachments that may interfere with the safe and proper raising of the machine. Always chock or block wheels. Use jack stands or solid wood blocks to support the raised machine. If the machine is not properly supported by blocks or jack stands, the machine may move or fall, which may result in personal injury.

Jacking the Front End (Fig. 1)

1. Set parking brake and chock both rear tires to prevent the machine from moving.

IMPORTANT: Do not place jack, jack stands, or blocks under the wheel motors. Wheel motors can be damaged if used for jacking or support points.

2. Position jack securely under the frame, just to the inside of the front tire.

3. Jack front of machine off the ground.

4. Position jack stands or hardwood blocks under the frame as close to the wheels as possible to support the machine.

Jacking the Rear End (Fig. 2)

1. Set parking brake and chock both front tires to prevent the machine from moving.

2. Place jack securely under the center of rear axle.

3. Jack rear of machine off the ground.

4. Position jack stands or hardwood blocks under the rear axle to support the machine.

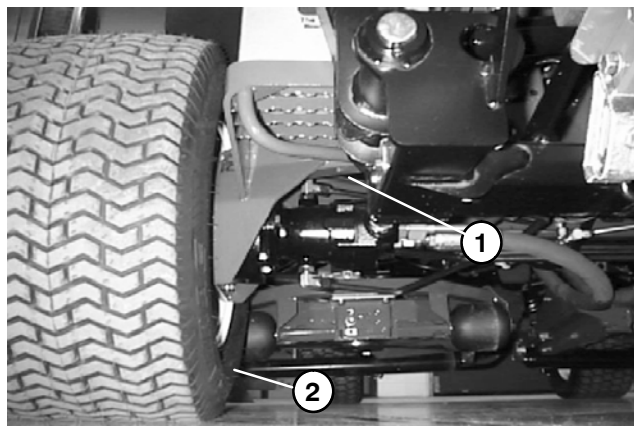

Figure 1

1. Frame

2. Front tire (RH shown)

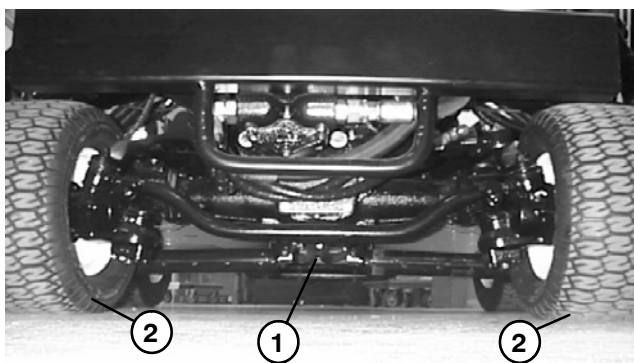

Figure 2

1. Rear axle

2. Rear tire

Safety and Instruction Decals

Numerous safety and instruction decals are affixed to the Groundsmaster 4500-D/4700-D. If any decal becomes illegible or damaged, install a new decal. Decal part numbers are listed in your Parts Catalog.



Product Records and Maintenance

Product Records and Maintenance

Table of Contents

PRODUCT RECORDS	1	Standard Torque for Dry, Zinc Plated, and Steel Fasteners (Inch Series)	4
MAINTENANCE	1	Standard Torque for Dry, Zinc Plated, and Steel Fasteners (Metric Fasteners)	5
EQUIVALENTS AND CONVERSIONS	2	Other Torque Specifications	6
Decimal and Millimeter Equivalents	2	Conversion Factors	6
U.S. to Metric Conversions	2		
TORQUE SPECIFICATIONS	3		
Fastener Identification	3		

Product Records

Insert Operator's Manual and Parts Catalog for your Groundsmaster 4500-D/4700-D at the end of this chapter. Additionally, if any optional equipment or accessories have been installed to your machine, insert the Installation Instructions, Operator's Manuals and Parts Catalogs for those options at the end of this chapter.

Maintenance

Maintenance procedures and recommended service intervals for the Groundsmaster 4500-D/4700-D are covered in the Operator's Manual. Refer to that publication when performing regular equipment maintenance.

Equivalents and Conversions

Decimal and Millimeter Equivalents

Fractions	Decimals	mm	Fractions	Decimals	mm		
	1/64	0.015625	— 0.397	33/64	0.515625	— 13.097	
	1/32	0.03125	— 0.794	17/32	0.53125	— 13.494	
	3/64	0.046875	— 1.191	35/64	0.546875	— 13.891	
1/16	—	0.0625	— 1.588	9/16	—	0.5625	— 14.288
	5/64	0.078125	— 1.984	37/64	0.578125	— 14.684	
	3/32	0.09375	— 2.381	19/32	—	0.59375	— 15.081
	7/64	0.109275	— 2.778	39/64	0.609375	— 15.478	
1/8	—	0.1250	— 3.175	5/8	—	0.6250	— 15.875
	9/64	0.140625	— 3.572	41/64	0.640625	— 16.272	
	5/32	0.15625	— 3.969	21/32	—	0.65625	— 16.669
	11/64	0.171875	— 4.366	43/64	0.671875	— 17.066	
3/16	—	0.1875	— 4.762	11/16	—	0.6875	— 17.462
	13/64	0.203125	— 5.159	45/64	0.703125	— 17.859	
	7/32	0.21875	— 5.556	23/32	—	0.71875	— 18.256
	15/64	0.234375	— 5.953	47/64	0.734375	— 18.653	
1/4	—	0.2500	— 6.350	3/4	—	0.7500	— 19.050
	17/64	0.265625	— 6.747	49/64	0.765625	— 19.447	
	9/32	0.28125	— 7.144	25/32	—	0.78125	— 19.844
	19/64	0.296875	— 7.541	51/64	0.796875	— 20.241	
5/16	—	0.3125	— 7.938	13/16	—	0.8125	— 20.638
	21/64	0.328125	— 8.334	53/64	0.828125	— 21.034	
	11/32	0.34375	— 8.731	27/32	—	0.84375	— 21.431
	23/64	0.359375	— 9.128	55/64	0.859375	— 21.828	
3/8	—	0.3750	— 9.525	7/8	—	0.8750	— 22.225
	25/64	0.390625	— 9.922	57/64	0.890625	— 22.622	
	13/32	0.40625	— 10.319	29/32	—	0.90625	— 23.019
	27/64	0.421875	— 10.716	59/64	0.921875	— 23.416	
7/16	—	0.4375	— 11.112	15/16	—	0.9375	— 23.812
	29/64	0.453125	— 11.509	61/64	0.953125	— 24.209	
	15/32	0.46875	— 11.906	31/32	—	0.96875	— 24.606
	31/64	0.484375	— 12.303	63/64	0.984375	— 25.003	
1/2	—	0.5000	— 12.700	1	—	1.000	— 25.400
	1 mm = 0.03937 in.			0.001 in. = 0.0254 mm			

U.S. to Metric Conversions

	To Convert	Into	Multiply By
Linear Measurement	Miles	Kilometers	1.609
	Yards	Meters	0.9144
	Feet	Meters	0.3048
	Feet	Centimeters	30.48
	Inches	Meters	0.0254
	Inches	Centimeters	2.54
	Inches	Millimeters	25.4
Area	Square Miles	Square Kilometers	2.59
	Square Feet	Square Meters	0.0929
	Square Inches	Square Centimeters	6.452
	Acre	Hectare	0.4047
Volume	Cubic Yards	Cubic Meters	0.7646
	Cubic Feet	Cubic Meters	0.02832
	Cubic Inches	Cubic Centimeters	16.39
Weight	Tons (Short)	Metric Tons	0.9078
	Pounds	Kilograms	0.4536
	Ounces (Avdp.)	Grams	28.3495
Pressure	Pounds/Sq. In.	Kilopascal	6.895
	Pounds/Sq. In.	Bar	0.069
Work	Foot-pounds	Newton-Meters	1.356
	Foot-pounds	Kilogram-Meters	0.1383
	Inch-pounds	Kilogram-Centimeters	1.152144
Liquid Volume	Quarts	Liters	0.9463
	Gallons	Liters	3.785
Liquid Flow	Gallons/Minute	Liters/Minute	3.785
Temperature	Fahrenheit	Celsius	1. Subtract 32°
			2. Multiply by 5/9

Torque Specifications

Recommended fastener torque values are listed in the following tables. For critical applications, as determined by Toro, either the recommended torque or a torque that is unique to the application is clearly identified and specified in this Service Manual.

These Torque Specifications for the installation and tightening of fasteners shall apply to all fasteners which do not have a specific requirement identified in this Service Manual. The following factors shall be considered when applying torque: cleanliness of the fastener, use of a thread sealant (e.g. Loctite), degree of lubrication on the fastener, presence of a prevailing torque feature, hardness of the surface underneath the fastener's head, or similar condition which affects the installation.

As noted in the following tables, torque values should be **reduced by 25% for lubricated fasteners** to achieve the similar stress as a dry fastener. Torque values may also have to be reduced when the fastener is threaded into aluminum or brass. The specific torque value should be determined based on the aluminum or brass material strength, fastener size, length of thread engagement, etc.

The standard method of verifying torque shall be performed by marking a line on the fastener (head or nut) and mating part, then back off fastener 1/4 of a turn. Measure the torque required to tighten the fastener until the lines match up.

Fastener Identification

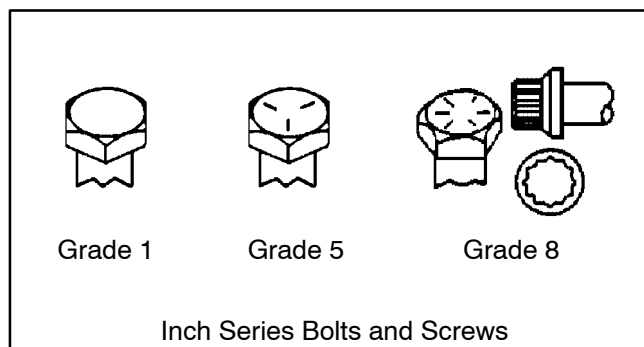

Figure 1

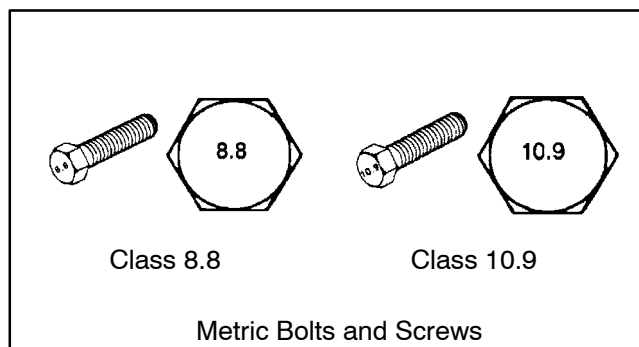

Figure 2



Kubota Diesel Engine

Table of Contents

GENERAL INFORMATION	2	Radiator	10
SPECIFICATIONS	3	Engine	12
ADJUSTMENTS	4	Engine Removal	13
Engine Run Solenoid	4	Engine Installation	14
SERVICE AND REPAIRS	5	Pump Adapter Plate	16
Air Filter System	5	KUBOTA WORKSHOP MANUAL, DIESEL ENGINE,	
Exhaust System	6	V2003-T SERIES	
Fuel System	8		
Check Fuel Lines and Connections	8		
Drain and Clean Fuel Tank	8		
Fuel Tank Removal	9		
Fuel Tank Installation	9		

Kubota
Diesel Engine

General Information

This Chapter gives information about specifications and repair of the diesel engine used in the Groundsmaster 4500-D/4700-D.

General maintenance procedures are described in your Traction Unit Operator's Manual. Information on engine troubleshooting, testing, disassembly and reassembly is identified in the Kubota Workshop Manual, Diesel Engine, V2003-T that is included at the end of this section.

Most repairs and adjustments require tools which are commonly available in many service shops. Special

tools are described in the Kubota Workshop Manual, Diesel Engine, V2003-T. The use of some specialized test equipment is explained. However, the cost of the test equipment and the specialized nature of some repairs may dictate that the work be done at an engine repair facility.

Service and repair parts for Kubota engines are supplied through your Authorized Toro Distributor. If no parts list is available, be prepared to provide your distributor with the Toro model and serial number.

Specifications

Item	Description
Make / Designation	Kubota, 4-Cycle, 4 Cylinder, Water Cooled, Turbocharged, Diesel Engine
Horse Power	58 HP (43.3 kW) @ 2600 RPM
Bore mm (in.)	83.0 (3.27)
Stroke mm (in.)	92.4 (3.64)
Total Displacement cc (cu. in.)	1999 (122.12)
Firing Order	1-3-4-2
Combustion Chamber	Spherical Type
Fuel	No. 2 Diesel Fuel (ASTM D975)
Fuel Capacity liters (U.S. gallons)	79.5 (21.0)
Fuel Injection Pump	Bosch Type Mini Pump (PFR)
Governor	Centrifugal Mechanical
Low Idle (no load)	1300 ± 50 RPM
High Idle (no load)	2800 ± 50 RPM
Direction of Rotation	Counterclockwise (Viewed from Flywheel)
Compression Ratio	22.0:1
Injection Nozzle	Bosch Throttle Type
Engine Oil	SAE 10W30 or 10W40 Detergent (API CD, or higher)
Oil Pump	Trochoid Type
Crankcase Oil Capacity liters (U.S. quarts)	7.6 (8.0) with Filter
Starter	12 VDC, 1.4 kW
Alternator/Regulator	12 VDC, 40 AMP
Coolant Capacity liters (U.S. quarts)	10.4 (11) with 0.9 (1.0) Reservoir
Engine Dry Weight kilograms (U.S. pounds)	184 (406)

Adjustments

Engine Run Solenoid

1. When ignition switch is in the RUN position, the engine run solenoid should energize and position the fuel stop lever to within 1/16" (1.6 mm) of stop on the injection pump.
2. If adjustment is needed, loosen lock nut and rotate the threaded end of the swivel until the lever is properly positioned.
3. Tighten lock nut. Recheck adjustment.

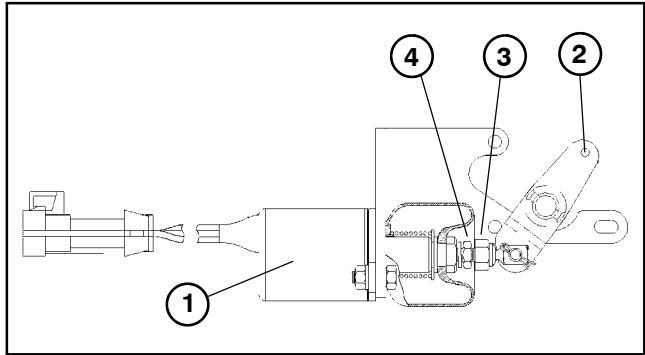

Figure 1

- | | |
|----------------------|-------------|
| 1. Run solenoid (ON) | 3. Swivel |
| 2. Lever | 4. Lock nut |

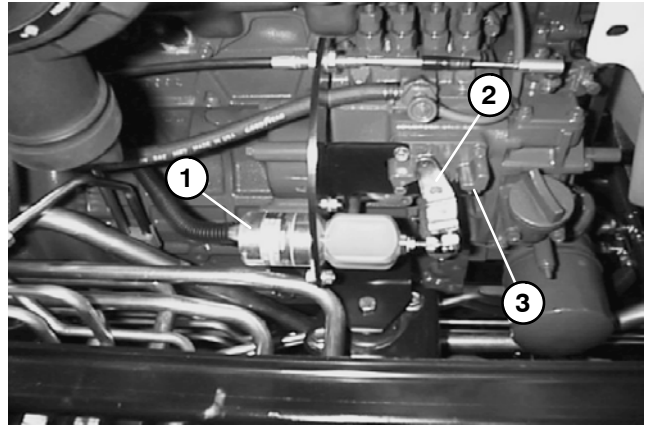

Figure 2

- | | |
|-----------------------|------------------------|
| 1. Run solenoid (OFF) | 3. Injection pump stop |
| 2. Solenoid lever | |

Service and Repairs

Air Filter System

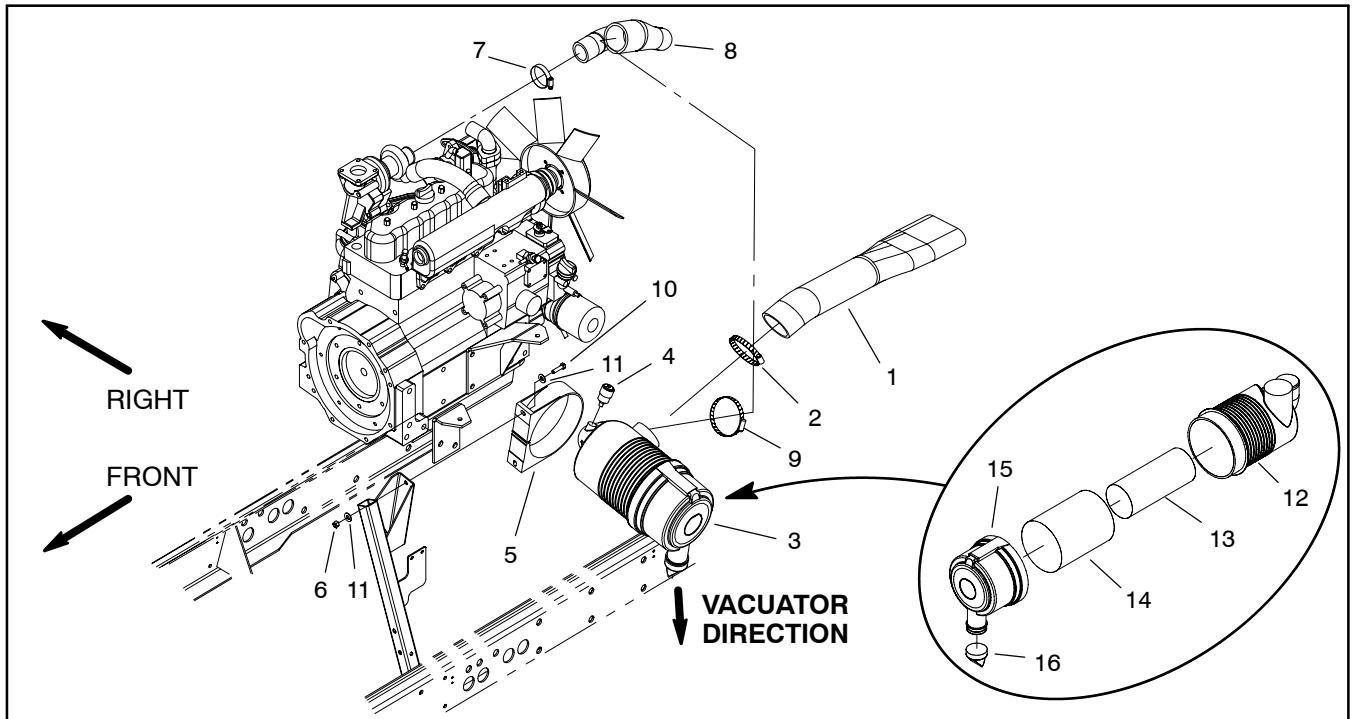

Figure 3

- | | | |
|-------------------------|---------------------|-----------------------|
| 1. Air cleaner hose | 7. Hose clamp | 12. Air cleaner body |
| 2. Hose clamp | 8. Air cleaner hose | 13. Filter element |
| 3. Air cleaner assembly | 9. Hose clamp | 14. Filter element |
| 4. Service indicator | 10. Cap screw | 15. Air cleaner cover |
| 5. Air cleaner strap | 11. Flat washer | 16. Vacuator valve |
| 6. Lock nut | | |

Removal

1. Remove air cleaner components as needed using Figure 3 as a guide.

Installation

IMPORTANT: Any leaks in the air filter system will cause serious engine damage. Make sure daily that all air cleaner components are in good condition and are properly secured during reassembly.

1. Assemble air filter system using Figure 3 as a guide.
2. When installing air cleaner hose (8) between air cleaner and turbo-charger (Fig. 4):
 - A. Make sure that hose does not contact engine valve cover. To modify clearance, move and/or rotate air cleaner body in air cleaner strap. Verify that tabs in strap mesh fully with slots in air cleaner body.
 - B. Position hose to allow 5/16" (7.9 mm) clearance between air cleaner hose and muffler bracket.

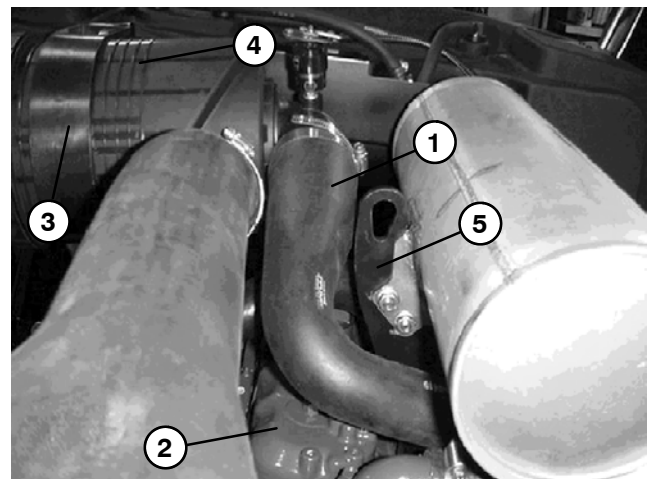

Figure 4

- | | |
|-----------------------|---------------------|
| 1. Air cleaner hose | 4. Air cleaner body |
| 2. Engine valve cover | 5. Muffler bracket |
| 3. Air cleaner strap | |

Kubota Diesel Engine



Suggest:

For more complete manuals. Please go to the home page.

<https://www.ebooklibonline.com>

If the above button click is invalid. Please download this document first, and then click the above link to download the complete manual.

Thank you so much for reading

Exhaust System

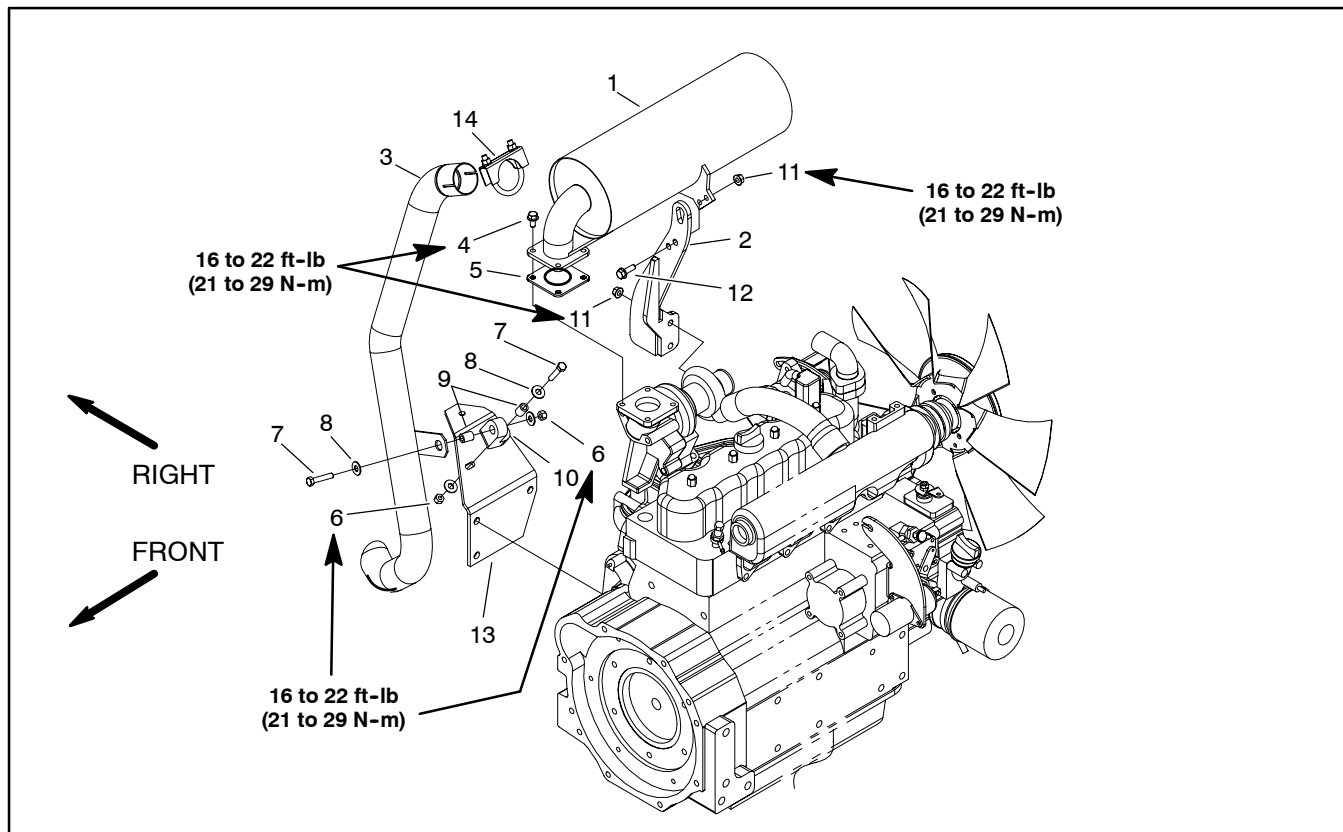

Figure 5

- | | | |
|-----------------------------|-------------------|-----------------------|
| 1. Muffler | 6. Lock nut | 11. Flange nut |
| 2. Muffler bracket/lift tab | 7. Cap screw | 12. Flange head screw |
| 3. Exhaust tailpipe | 8. Flat washer | 13. Engine mount |
| 4. Flange head screw | 9. Spacer | 14. Muffler clamp |
| 5. Exhaust gasket | 10. Rubber hanger | |

Removal



CAUTION

The muffler and exhaust pipe may be hot. To avoid possible burns, allow the engine and exhaust system to cool before working on the muffler.

1. Park machine on a level surface, lower cutting units, stop engine, engage parking brake, and remove key from the ignition switch.
2. Remove muffler and/or muffler bracket from the engine as necessary using Figure 5 as a guide.

Installation

NOTE: Make sure muffler flange and exhaust manifold sealing surfaces are free of debris or damage that may prevent a tight seal.

1. Install **new** gasket if original gasket is damaged or torn.

IMPORTANT: Failure to follow the suggested muffler fastener sequence may result in premature muffler failure.

2. Install muffler and/or muffler bracket to the engine using Figure 5 as a guide. Hand tighten and then torque the following fasteners from 16 to 22 ft-lb (21 to 29 N-m) in the sequence listed (Fig. 6):

- A. Locknuts used on rubber hanger cap screws.
- B. Flange nuts that secure muffler to muffler bracket.
- C. Flange head screws that secure muffler flange to engine.
- D. Flange nuts that secure muffler bracket to engine.

3. Adjust tailpipe so it has equal clearance between frame and engine before tightening muffler clamp.

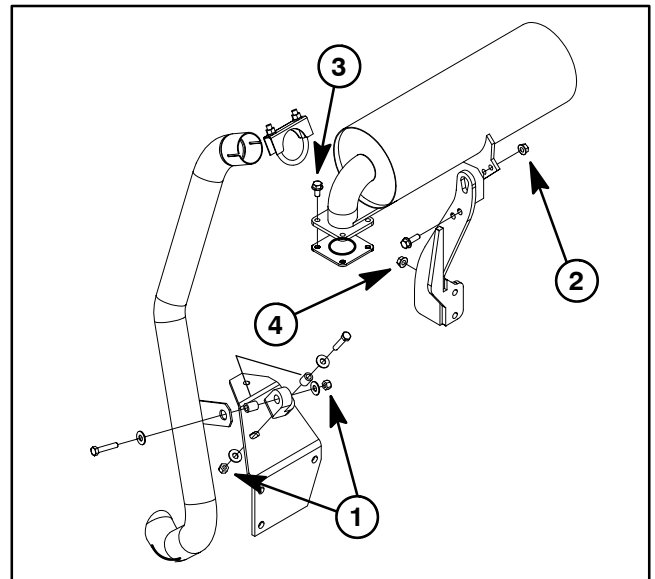

Figure 6

<https://www.ebooklibonline.com>

Hello dear friend!

Thank you very much for reading.

Enter the link into your browser.

The full manual is available for immediate download.

<https://www.ebooklibonline.com>