

SECTION 8 DISASSEMBLY AND ASSEMBLY

Group 1 Precaution	8-1
Group 2 Tightening Torque	8-4
Group 3 Pump Device	8-7
Group 4 Main Control Valve	8-36
Group 5 Swing Device	8-49
Group 6 Travel Device	8-74
Group 7 RCV Lever	8-114
Group 8 Turning Joint	8-128
Group 9 Boom, Arm and Bucket Cylinder	8-133
Group 10 Undercarriage	8-150
Group 11 Work Equipment	8-162

SECTION 8 DISASSEMBLY AND ASSEMBLY

GROUP 1 PRECAUTIONS

1. REMOVAL WORK

- 1) Lower the work equipment completely to the ground.
If the coolant contains antifreeze, dispose of it correctly.
- 2) After disconnecting hoses or tubes, cover them or fit blind plugs to prevent dirt or dust from entering.
- 3) When draining oil, prepare a container of adequate size to catch the oil.
- 4) Confirm the match marks showing the installation position, and make match marks in the necessary places before removal to prevent any mistake when assembling.
- 5) To prevent any excessive force from being applied to the wiring, always hold the connectors when disconnecting the connectors.
- 6) Fit wires and hoses with tags to show their installation position to prevent any mistake when installing.
- 7) Check the number and thickness of the shims, and keep in a safe place.
- 8) When raising components, be sure to use lifting equipment of ample strength.
- 9) When using forcing screws to remove any components, tighten the forcing screws alternately.
- 10) Before removing any unit, clean the surrounding area and fit a cover to prevent any dust or dirt from entering after removal.
- 11) When removing hydraulic equipment, first release the remaining pressure inside the hydraulic tank and the hydraulic piping.
- 12) If the part is not under hydraulic pressure, the following corks can be used.

Nominal number	Dimensions		
	D	d	L
06	6	5	8
08	8	6.5	11
10	10	8.5	12
12	12	10	15
14	14	11.5	18
16	16	13.5	20
18	18	15	22
20	20	17	25
22	22	18.5	28
24	24	20	30
27	27	22.5	34

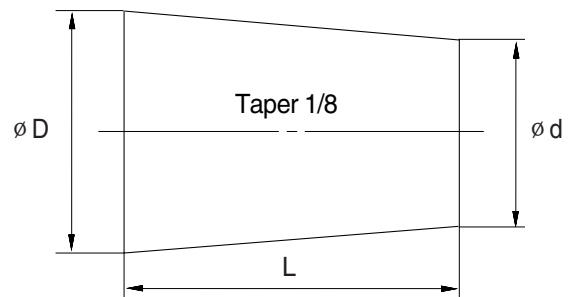

2. INSTALL WORK

- 1) Tighten all bolts and nuts(Sleeve nuts) to the specified torque.
- 2) Install the hoses without twisting or interference.
- 3) Replace all gaskets, O-rings, cotter pins, and lock plates with new parts.
- 4) Bend the cotter pin or lock plate securely.
- 5) When coating with adhesive, clean the part and remove all oil and grease, then coat the threaded portion with 2-3 drops of adhesive.
- 6) When coating with gasket sealant, clean the surface and remove all oil and grease, check that there is no dirt or damage, then coat uniformly with gasket sealant.
- 7) Clean all parts, and correct any damage, dents, burrs, or rust.
- 8) Coat rotating parts and sliding parts with engine oil.
- 9) When press fitting parts, coat the surface with antifriction compound(LM-P).
- 10) After installing snap rings, check that the snap ring is fitted securely in the ring groove(Check that the snap ring moves in the direction of rotation).
- 11) When connecting wiring connectors, clean the connector to remove all oil, dirt, or water, then connect securely.
- 12) When using eyebolts, check that there is no deformation or deterioration, and screw them in fully.
- 13) When tightening split flanges, tighten uniformly in turn to prevent excessive tightening on one side.
- 14) When operating the hydraulic cylinders for the first time after repairing and reassembling the hydraulic cylinders, pumps, or other hydraulic equipment or piping, always bleed the air from the hydraulic cylinders as follows:
 - (1) Start the engine and run at low idling.
 - (2) Operate the control lever and actuate the hydraulic cylinder 4-5 times, stopping 100mm before the end of the stroke.
 - (3) Next, operate the piston rod to the end of its stroke to relieve the circuit. (The air bleed valve is actuated to bleed the air.)
 - (4) After completing this operation, raise the engine speed to the normal operating condition.
 - ※ If the hydraulic cylinder has been replaced, carry out this procedure before assembling the rod to the work equipment.
 - ※ Carry out the same operation on machines that have been in storage for a long time after completion of repairs.

<https://www.ebooklibonline.com>

Hello dear friend!

Thank you very much for reading.

Enter the link into your browser.

The full manual is available for immediate download.

<https://www.ebooklibonline.com>

3. COMPLETING WORK

- 1) If the coolant has been drained, tighten the drain valve, and add water to the specified level. Run the engine to circulate the water through the system. Then check the water level again.
- 2) If the hydraulic equipment has been removed and installed again, add engine oil to the specified level. Run the engine to circulate the oil through the system. Then check the oil level again.
- 3) If the piping or hydraulic equipment, such as hydraulic cylinders, pumps, or motors, have been removed for repair, always bleed the air from the system after reassembling the parts.
- 4) Add the specified amount of grease(Molybdenum disulphied grease) to the work equipment related parts.

GROUP 2 TIGHTENING TORQUE

1. MAJOR COMPONENTS

No.	Descriptions	Bolt size	Torque		
			kgf · m	lbf · ft	
1	Engine	Engine mounting bolt, nut	M20 × 2.5	46.4 ± 4.6	336 ± 33
2		Radiator mounting bolt	M16 × 2.0	29.7 ± 4.5	215 ± 32.5
3		Coupling mounting socket bolt	M10 × 1.5	4.6 ± 1.0	33 ± 7.9
4		Main pump housing mounting bolt	M10 × 1.5	4.6 ± 1.0	33 ± 7.9
5	Hydraulic system	Main pump mounting bolt	M20 × 2.5	4.4 ± 0.6	318 ± 47.7
6		Main control valve mounting nut	M12 × 1.75	12.2 ± 1.3	88.2 ± 9.4
7		Fuel tank mounting bolt	M20 × 2.5	45 ± 5.1	325 ± 36.8
8		Hydraulic oil tank mounting bolt	M20 × 2.5	45 ± 5.1	325 ± 36.8
9		Turning joint mounting bolt, nut	M16 × 2.5	29.7 ± 4.5	215 ± 32.5
10	Power train system	Swing motor mounting bolt	M20 × 2.5	58.4 ± 6.4	422 ± 46.2
11		Swing bearing upper part mounting bolt	M24 × 3.0	94.5 ± 10.5	683 ± 75.9
12		Swing bearing lower part mounting bolt	M24 × 3.0	94.5 ± 10.5	683 ± 75.9
13		Travel motor mounting bolt	M20 × 2.5	57.9 ± 8.7	419 ± 62.9
14		Sprocket mounting bolt	M20 × 2.5	57.9 ± 8.7	419 ± 62.9
15	Under carriage	Carrier roller mounting bolt, nut	M16 × 1.5	31.3 ± 4.7	226 ± 33.9
16		Track roller mounting bolt	M22 × 2.5	83.2 ± 12.5	601 ± 90.4
17		Track tension cylinder mounting bolt	M16 × 2.0	76 ± 8	550 ± 58
18		Track shoe mounting bolt, nut (-#0595)	M22 × 1.5	105 ± 5.0	760 ± 36
19		Track shoe mounting bolt, nut (#0596-)	M24 × 1.5	140 ± 5.0	1012 ± 36
20	Others	Counterweight mounting bolt	M42 × 3.0	390 ± 40	2821 ± 289
		Center frame support & lower track mounting bolt	M33 × 3.5	220 ± 20	88.2 ± 9.4
21		Cab mounting bolt	M12 × 1.75	12.2 ± 1.3	18.1 ± 3.6
22		Operator's seat mounting bolt	M 8 × 1.25	2.5 ± 0.5	1591 ± 145

※ For tightening torque of engine and hydraulic components, see engine maintenance guide and service manual.

2. TORQUE CHART

Use following table for unspecified torque.

1) BOLT AND NUT - Coarse thread

Bolt size	8T		10T	
	kgf · m	lbf · ft	kgf · m	lbf · ft
M 6 × 1.0	0.85 ~ 1.25	6.15 ~ 9.04	1.14 ~ 1.74	8.2 ~ 12.6
M 8 × 1.25	2.0 ~ 3.0	14.5 ~ 21.7	2.7 ~ 4.1	19.5 ~ 29.7
M10 × 1.5	4.0 ~ 6.0	28.9 ~ 43.4	5.5 ~ 8.3	39.8 ~ 60.0
M12 × 1.75	7.4 ~ 11.2	53.5 ~ 81.0	9.8 ~ 15.8	70.9 ~ 114
M14 × 2.0	12.2 ~ 16.6	88.2 ~ 120	16.7 ~ 22.5	121 ~ 163
M16 × 2.0	18.6 ~ 25.2	135 ~ 182	25.2 ~ 34.2	182 ~ 247
M18 × 2.0	25.8 ~ 35.0	187 ~ 253	35.1 ~ 47.5	254 ~ 344
M20 × 2.5	36.2 ~ 49.0	262 ~ 354	49.2 ~ 66.6	356 ~ 482
M22 × 2.5	48.3 ~ 63.3	349 ~ 458	65.8 ~ 98.0	476 ~ 709
M24 × 3.0	62.5 ~ 84.5	452 ~ 611	85.0 ~ 115	615 ~ 832
M30 × 3.0	124 ~ 168	898 ~ 1214	169 ~ 229	1223 ~ 1656
M36 × 4.0	174 ~ 236	1261 ~ 1704	250 ~ 310	1808 ~ 2242

(2) Fine thread

Bolt size	8T		10T	
	kgf · m	lbf · ft	kgf · m	lbf · ft
M 8 × 1.0	2.2 ~ 3.4	15.9 ~ 24.6	3.0 ~ 4.4	21.7 ~ 31.8
M10 × 1.2	4.5 ~ 6.7	32.5 ~ 48.5	5.9 ~ 8.9	42.7 ~ 64.4
M12 × 1.25	7.8 ~ 11.6	56.4 ~ 83.9	10.6 ~ 16.0	76.7 ~ 116
M14 × 1.5	13.3 ~ 18.1	96.2 ~ 131	17.9 ~ 24.1	130 ~ 174
M16 × 1.5	19.9 ~ 26.9	144 ~ 195	26.6 ~ 36.0	192 ~ 260
M18 × 1.5	28.6 ~ 43.6	207 ~ 315	38.4 ~ 52.0	278 ~ 376
M20 × 1.5	40.0 ~ 54.0	289 ~ 391	53.4 ~ 72.2	386 ~ 522
M22 × 1.5	52.7 ~ 71.3	381 ~ 516	70.7 ~ 95.7	511 ~ 692
M24 × 2.0	67.9 ~ 91.9	491 ~ 665	90.9 ~ 123	658 ~ 890
M30 × 2.0	137 ~ 185	990 ~ 1339	182 ~ 248	1314 ~ 1796
M36 × 3.0	192 ~ 260	1390 ~ 1880	262 ~ 354	1894 ~ 2562

2) PIPE AND HOSE

Thread size	Width across flat(mm)	kgf · m	lbf · ft
1/4"	19	3	21.7
3/8"	22	4	28.9
1/2"	27	5	36.2
3/4"	36	12	86.8
1"	41	14	101

3) FITTING

Thread size	Width across flat(mm)	kgf · m	lbf · ft
1/4"	19	4	28.9
3/8"	22	5	36.2
1/2"	27	6	43.4
3/4"	36	13	94.0
1"	41	15	109

GROUP 3 PUMP DEVICE

1. REMOVAL AND INSTALL

1) REMOVAL

(1) Lower the work equipment to the ground and stop the engine.

(2) Loosen the breather slowly to release the pressure inside the hydraulic tank.

▲ Escaping fluid under pressure can penetrate the skin causing serious injury.

(3) Loosen the drain plug under the hydraulic tank and drain the oil from the hydraulic tank.

· Hydraulic tank quantity : 250 l

(4) Remove bolts(16) and disconnect pipe (1,2).

(5) Disconnect pilot line hoses(4, 5, 6, 7, 8, 9, 10, 11, 12, 13, 14).

(6) Remove bolts(15) and disconnect pump suction tube (3).

※ When pump suction tube is disconnected, the oil inside the piping will flow out, so catch it in oil pan.

(7) Sling the pump assembly and remove the pump mounting bolts.

· Weight : 240kg(530lb)

※ Pull out the pump assembly from housing. When removing the pump assembly, check that all the hoses have been disconnected.



13031GE18

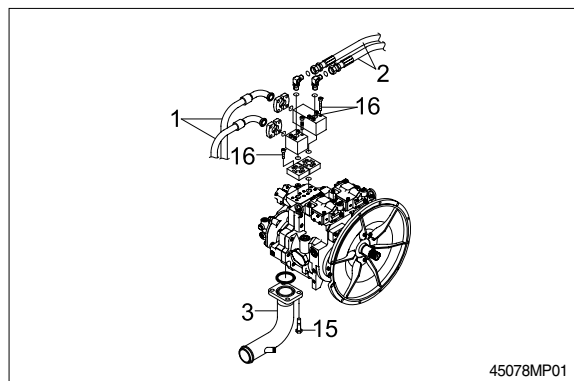

45078MP01

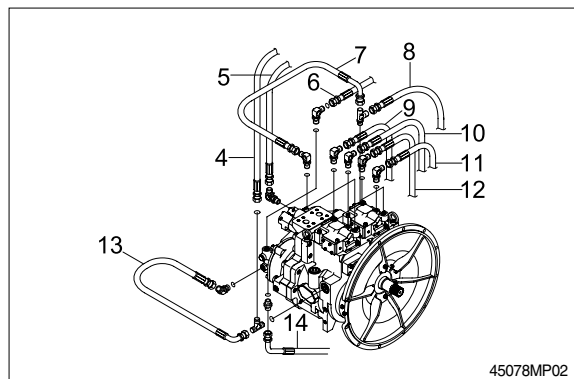

45078MP02

2) INSTALL

- (1) Carry out installation in the reverse order to removal
- (2) Remove the suction strainer and clean it.
- (3) Replace the return filter with a new one.
- (4) Remove breather and clean it.
- (5) After adding oil to the hydraulic tank to the specified level.
- (6) Bleed the air from the hydraulic pump.
 - ① Remove the air vent plug(2EA)
 - ② Tighten plug lightly
 - ③ Start the engine, run at low idling, and check oil come out from plug.
 - ④ Tighten plug.
- (7) Start the engine, run at low idling(3~5 minutes) to circulate the oil through the system.
- (8) Confirmed the hydraulic oil level and check the hydraulic oil leaks or not.

2. MAIN PUMP(1/2)

1) STRUCTURE

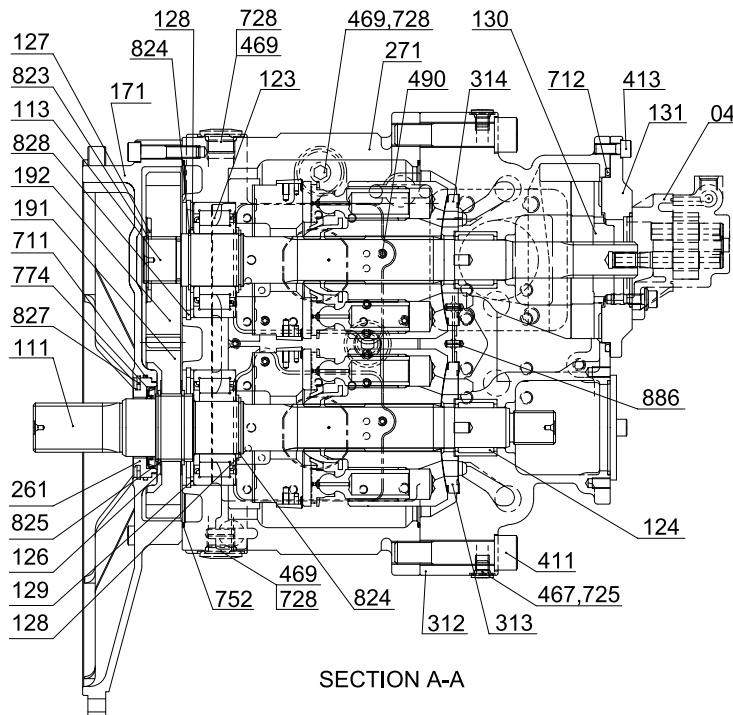
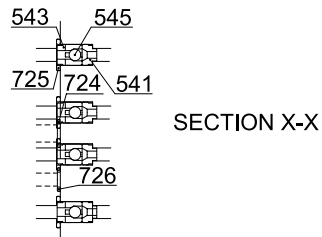
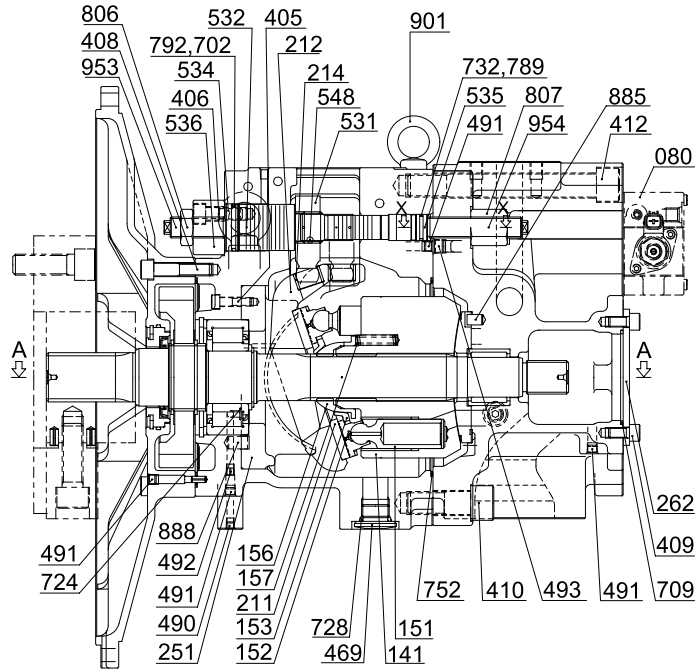

04	Gear pump	262	Cover	548	Feed back pin
080	Proportional reducing valve assy	271	Pump casing	702	O-ring
111	Drive shaft	312	Valve cover	709	O-ring
113	Driven shaft	313	Valve plate(R)	711	O-ring
123	Roller bearing	314	Valve plate(L)	712	O-ring
124	Needle bearing	405	Hexagon socket bolt	724	O-ring
126	Spacer	406	Hexagon socket bolt	725	O-ring
127	Spacer	408	Hexagon socket bolt	726	O-ring
128	Bearing spacer	409	Hexagon socket bolt	728	O-ring
129	Bearing spacer	410	Hexagon socket bolt	732	O-ring
130	Booster	411	Hexagon socket bolt	752	Seat packing
131	Booster cover	412	Hexagon socket bolt	774	Oil seal
141	Cylinder block	413	Hexagon socket bolt	789	Back up ring
151	Piston	467	Plug	792	Back up ring
152	Shoe	469	Plug	806	Nut
153	Plate	490	Plug	807	Nut
156	Bushing	491	Plug	823	Snap ring
157	Cylinder spring	492	Restrictor	824	Snap ring
171	Front casing	493	Plug	825	Snap ring
191	Drive gear	531	Tilting pin	827	Snap ring
192	Driven gear	532	Servo piston	828	Snap ring
211	Shoe plate	534	Stopper(L)	885	Valve plate pin
212	Swash plate	535	Stopper(S)	886	Spring pin
214	Tilting bushing bushing	536	Servo cover	888	Pin
251	Swash plate support	541	Seat	901	Eye bolt
261	Front cover	543	Stopper	953	Set screw
		545	Steel ball	954	Set screw

MAIN PUMP(2/2)

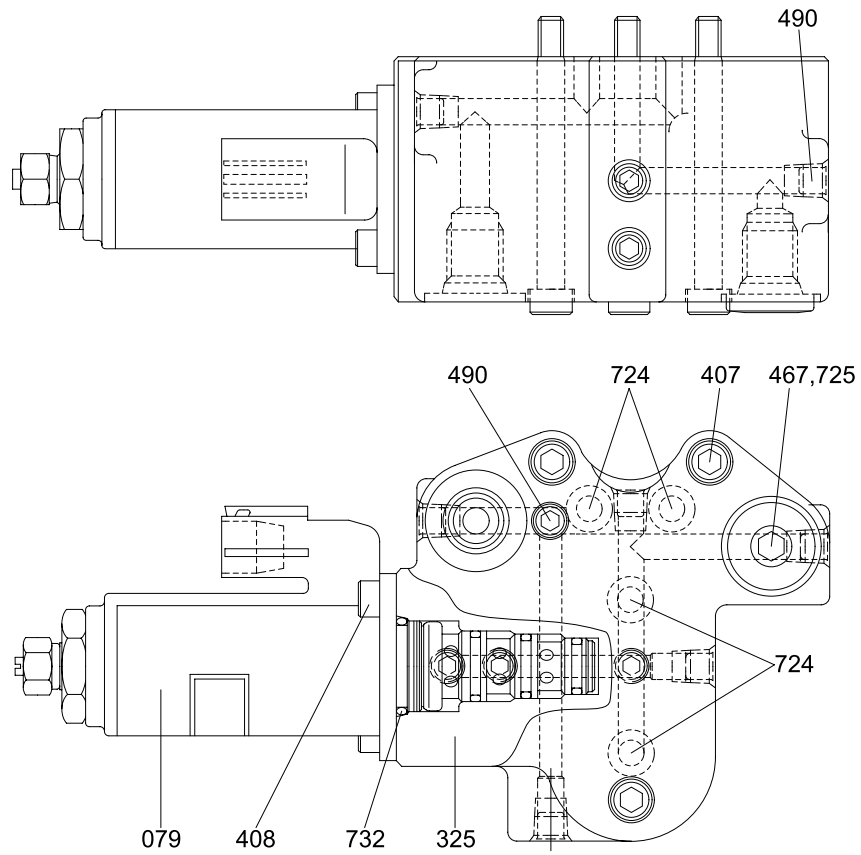



45070MP04

079	Proportional reducing valve	408	Hexagon screw	724	O-ring
325	Valve casing	467	Plug	725	O-ring
407	Hexagon screw	490	Plug	732	O-ring

2) TOOLS AND TIGHTENING TORQUE

(1) Tools

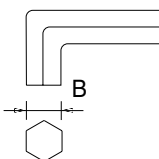
The tools necessary to disassemble/reassemble the pump are shown in the follow list.

Tool name & size		Part name			
Allen wrench 	B	Hexagon socket head cap screw	PT plug (PT thread)	PO plug (PF thread)	Servo piston
	4	M 5	BP-1/16	-	-
	5	M 6	BP-1/ 8	-	-
	6	M 8	BP-1/ 4	PF-1/4	-
	8	M10	BP-3/ 8	PF-3/8	-
	10	M12	BP-1/2	PF-1/2	-
	14	M16, M18	BP-3/4	PF-3/4	-
	17	M20, M22	BP-1	PF-1	M30
Double ring spanner, socket wrench, double(Single) open end spanner 	-	Hexagon head screw	Hexagon nut	Hexagon socket head set screw	
	10	M6	M6	-	
	13	M8	M8	M20	
	30	M20	M20	-	
Adjustable angle wrench	Medium size, 1 set				
Screw driver	Minus type screw driver, Medium size, 2 sets				
Hammer	Plastic hammer, 1 set				
Pliers	For snap ring, TSR-160, TSR200, TRR200				
Steel bar	Steel bar of key material approx. 10×8×200				
Torque wrench	Capable of tightening with the specified torques				
Seal tape	For BP-1/4				

(2) Tightening torque

Part name	Bolt size	Torque		Wrench size	
		kgf · m	lbf · ft	in	mm
Hexagon socket head bolt (Material : SCM435)	M 5	0.7	5.1	0.16	4
	M 6	1.2	8.7	0.20	5
	M 8	3.0	21.7	0.24	6
	M10	5.8	42.0	0.31	8
	M12	10.0	72.3	0.39	10
	M14	16.0	115.7	0.47	12
	M16	24.0	173.6	0.55	14
	M18	34.0	245.9	0.55	14
	M20	44.0	318.3	0.67	17
	M22	64.0	462.9	0.67	17
PT plug(Material : S45C) ※ Wind a seal tape 1 1/2 to 2 turns round the plug	PT 1/16	0.7	5.1	0.16	4
	PT 1/ 8	1.05	7.59	0.20	5
	PT 1/ 4	1.75	12.66	0.24	6
	PT 3/ 8	3.5	25.3	0.31	8
	PT 1/ 2	5.0	36.2	0.39	10
PF plug(Material : S45C)	PF 1/ 4	3.0	21.7	0.24	6
	PF 1/ 2	10.0	72.3	0.39	10
	PF 3/ 4	15.0	108.5	0.55	14
	PF 1	19.0	137.4	0.67	17
	PF 1 1/4	27.0	195.3	0.67	17
	PF 1 1/2	28.0	202.5	0.67	17

3) DISASSEMBLY

- (1) Select place suitable to disassembling.
 - ※ Select clean place.
 - ※ Spread rubber sheet, cloth or so on overhaul workbench top to prevent parts from being damaged.
 - ※ Fix pump casing(271) by using thread 2-M10 × 16 in disassembling.



45078MP28

- (2) Remove dust, rust, etc, from pump surfaces with cleaning oil or so on.
- (3) Remove outlet port plug(469, lower part of pump casing) and let the oil out of pump casing.
 - ※ In order to be let the oil out of pump casing easily, remove oil filling port plug(469, upper part of pump casing).

- (4) Remove hexagon socket head cap screws(412, 413) and remove regulators.
 - ※ In order to avoid mixing up regulator of drive shaft side with that of driven shaft side, mark each of them.



45078MP29

- (5) Remove gear pump, booster cover(131), booster(130), and cover(262).

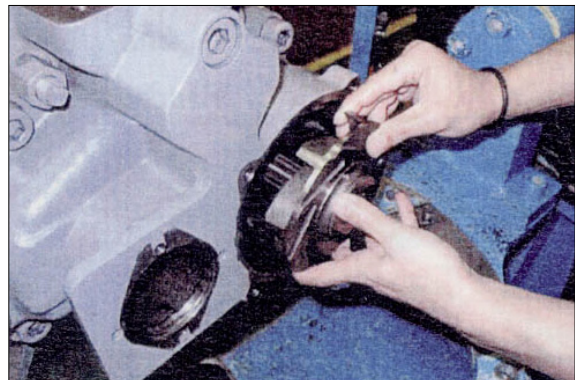

45078MP23



Suggest:

For more complete manuals. Please go to the home page.

<https://www.ebooklibonline.com>

If the above button click is invalid. Please download this document first, and then click the above link to download the complete manual.

Thank you so much for reading

(6) Loosen hexagon socket head cap screws(410, 411, 412) which tighten valve cover(312).

※ Remove regulators before starting this work.

(7) Place pump horizontally on workbench and separate pump casing(271) and valve cover(312).

※ Crane valve cover(312) at this work because it is heavy(about 60kgf).

※ There are two spring pins for fixing position between pump casing(271) and valve cover(312). Since they have a tight fit, remove valve cover(312) upright with respect to drive shaft(111) and driven shaft(113), while lightly tapping the valve cover(312) with a plastic hammer.

※ Take care not to damage fitting surfaces between pump casing(271) and valve cover(312). Take care not to drop valve plates(313, 314), check valve subassemblies(541, 543, 545), O-rings (724, 725, 726) and seat packing(752) in removing valve cover(312).



45078MP03

(8) If necessary, remove needle bearings (124) from valve cover(312).

※ Do not remove needle bearings as far as possible, except when it is considered to be out of its life span.

※ Do not loosen hexagon nut(807) of the valve cover. If loosened, flow setting will be changed.

(9) Pull cylinders out of pump casing(271) straightly over drive shaft(111) and driven shaft(113). Pull out also pistons(151), set plate(153), spherical bush(156) and cylinder springs(157) simultaneously.

- ※ Take care not to damage sliding surfaces of cylinder, spherical bush, shoes, swash plate, and so on.



45078MP04

(10) Remove shoe plate(211) and swash plate(212) from pump casing(271).



45078MP05

(11) If necessary, remove stopper(L, 534), stopper(S, 535), servo piston(532), tilting pin(531), and servo cover(536), from pump casing(271).

- ※ In removing tilting pin, use a protector to prevent pin head from being damaged.
- ※ Since adhesive(No.1305N of threebond make) is applied to fitting areas of tilting pin and servo piston, take care not to damage servo piston.
- ※ Do not loosen hexagon nut(806) on servo cover(536). If loosened, flow setting will be changed.

<https://www.ebooklibonline.com>

Hello dear friend!

Thank you very much for reading.

Enter the link into your browser.

The full manual is available for immediate download.

<https://www.ebooklibonline.com>