

Page Number	Page Title	Page Reference
01-000-TOC	ENGINE, FUEL AND EXHAUST SYSTEM	01-000-TOC
02-000-TOC	AXLES	02-000-TOC
03-000-TOC	DRIVE TRAIN SYSTEM	03-000-TOC
04-000-TOC	HYDRAULIC SYSTEM	04-000-TOC
05-000-TOC	ELECTRICAL SYSTEM	05-000-TOC
06-000-TOC	CAB	06-000-TOC
07-000-TOC	CHASSIS	07-000-TOC
08-000-TOC	WHEELS	08-000-TOC
09-000-TOC	IMPLEMENT DRIVE SYSTEM	09-000-TOC
10-000-TOC	LINKAGE	10-000-TOC
11-000-TOC	ACCESSORIES	11-000-TOC
12-000-TOC	GENERAL INFORMATION	12-000-TOC

MF 7614 TRACTOR (DYNA 4)
CYLINDER-BLOCK

1-WH01-023-A

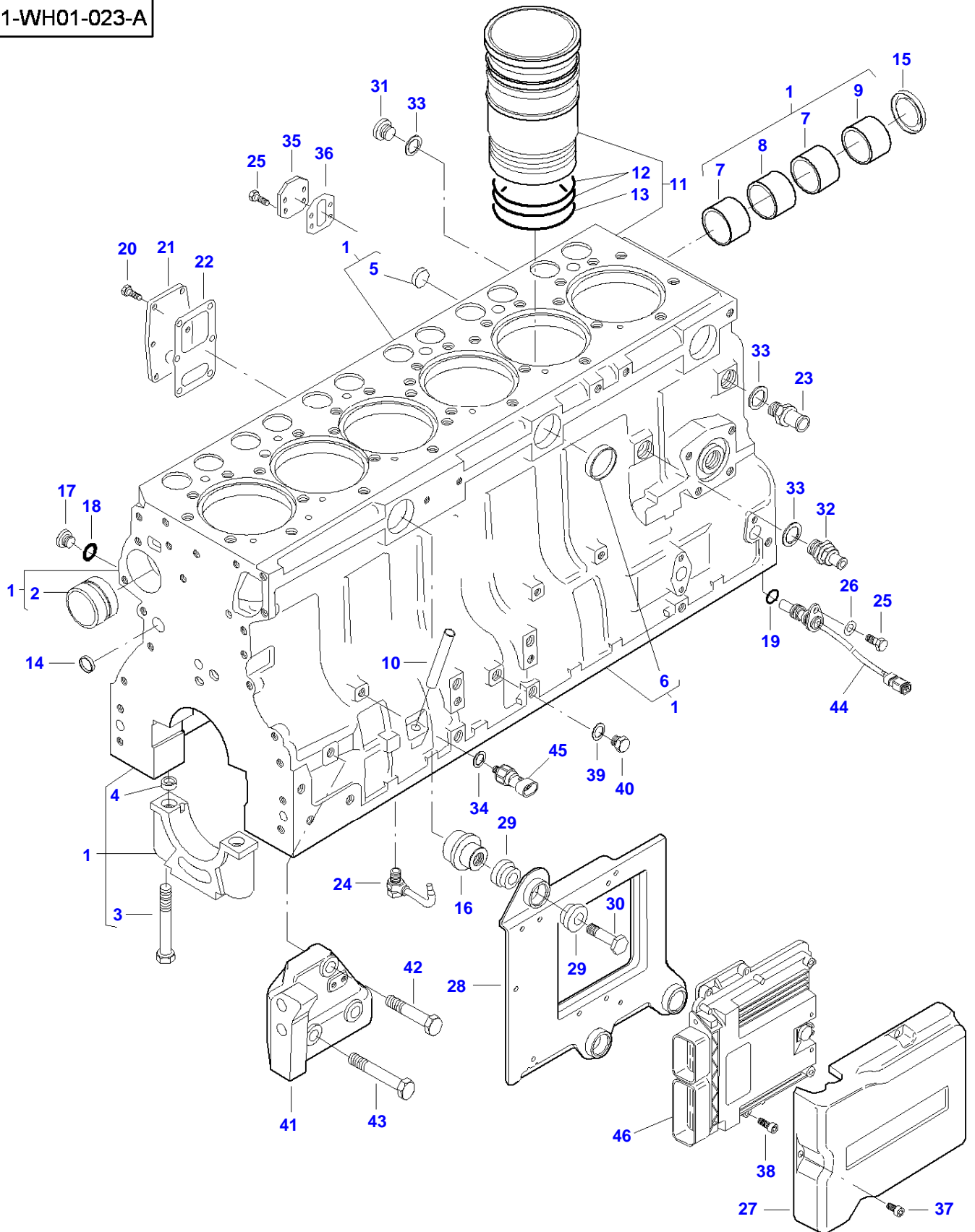

Item	Part Number	Qty	Description Comments
1	V837070103	1	CYLINDER BLOCK
2	V836866069	1	CAMSHAFT BEARING BUSHING (1)
	V836866036	X	CAMSHAFT BEARING BUSHING THICKNESS + 0.4 MM
3	V835329030	14	HEX CAP SCREW (1)
4	V836214478	24	GUIDE SLEEVE (1)
5	V640016018	1	PLUG (1)
6	V640016040	2	PLUG (1)
7	V836852460	2	CAMSHAFT BEARING BUSHING (1)
8	V836852459	1	CAMSHAFT BEARING BUSHING (1)
9	V836852461	1	CAMSHAFT BEARING BUSHING (1)
10	V836666910	1	OIL DIPSTICK GUIDE PIPE
11	V836673191	6	LINER
	V836647933	X	LINER THICKNESS 9.08 MM
	V836647934	X	LINER THICKNESS 9.13 MM
	V836647935	X	LINER THICKNESS 9.23 MM
12	V836647502	12	CYLINDER LINER O-RING (11) [A]
13	V836647503	6	CYLINDER LINER O-RING (11) [A]
14	V640016016	4	PLUG [A]
15	V836852744	1	PLUG
16	V837069057	1	PLUG
17	V640325110	4	PLUG
18	V615871014	4	SEALING WASHER [A]
19	V614601524	1	O-RING
20	V528801380	6	HEX CAP SCREW M8 X 20
21	V836847994	1	FLANGE
22	V836322852	1	GASKET [A]
23	V836119837	1	HOSE COUPLER
24	V837074224	6	PISTON COOLING JET
25	V528801362	5	HEX CAP SCREW
26	V500050840	1	FLAT WASHER
27	V837073901	1	COVER
28	V837073900	1	ECU BRACKET
29	V837074327	6	RUBBER BUSHING
	V837084129	6	DAMPER [B]
30	V837069056	3	SCREW
31	V640325018	1	PLUG
32	V836664377	1	COCK
33	V615881824	3	SEALING WASHER [A]
34	V615871016	1	SEALING WASHER [A]
35	V836866957	1	COVER
36	V836866958	1	GASKET [A]
37	V581804182	3	HEX SOCKET SCREW M6 X 16

<https://www.ebooklibonline.com>

Hello dear friend!

Thank you very much for reading.

Enter the link into your browser.

The full manual is available for immediate download.

<https://www.ebooklibonline.com>

Item	Part Number	Qty	Description Comments
38	V581804202	4	HEX SOCKET SCREW M6 X 20
39	V615881216	1	SEALING WASHER [A]
40	V640045112	1	PLUG
41	V836867635	1	ENGINE MOUNT LEFT HAND
41	V836867636	1	ENGINE MOUNT RIGHT HAND
42	V529902680	4	HEX CAP SCREW M14 X 65
43	V529902720	4	HEX CAP SCREW M14 X 85
44		1	SPEED SENSOR SEE PAGE 01-0025
45		1	OIL PRESS SWITCH SEE PAGE 01-0025
46		1	CONTROL UNIT SEE PAGE 01-0025 [A] INCLUDED IN GASKET SET FOR ENGINE [B] TIER2 ENGINE

MF 7614 TRACTOR (DYNA 4)
TIMING GEAR HOUSING

1-WH20-016-A

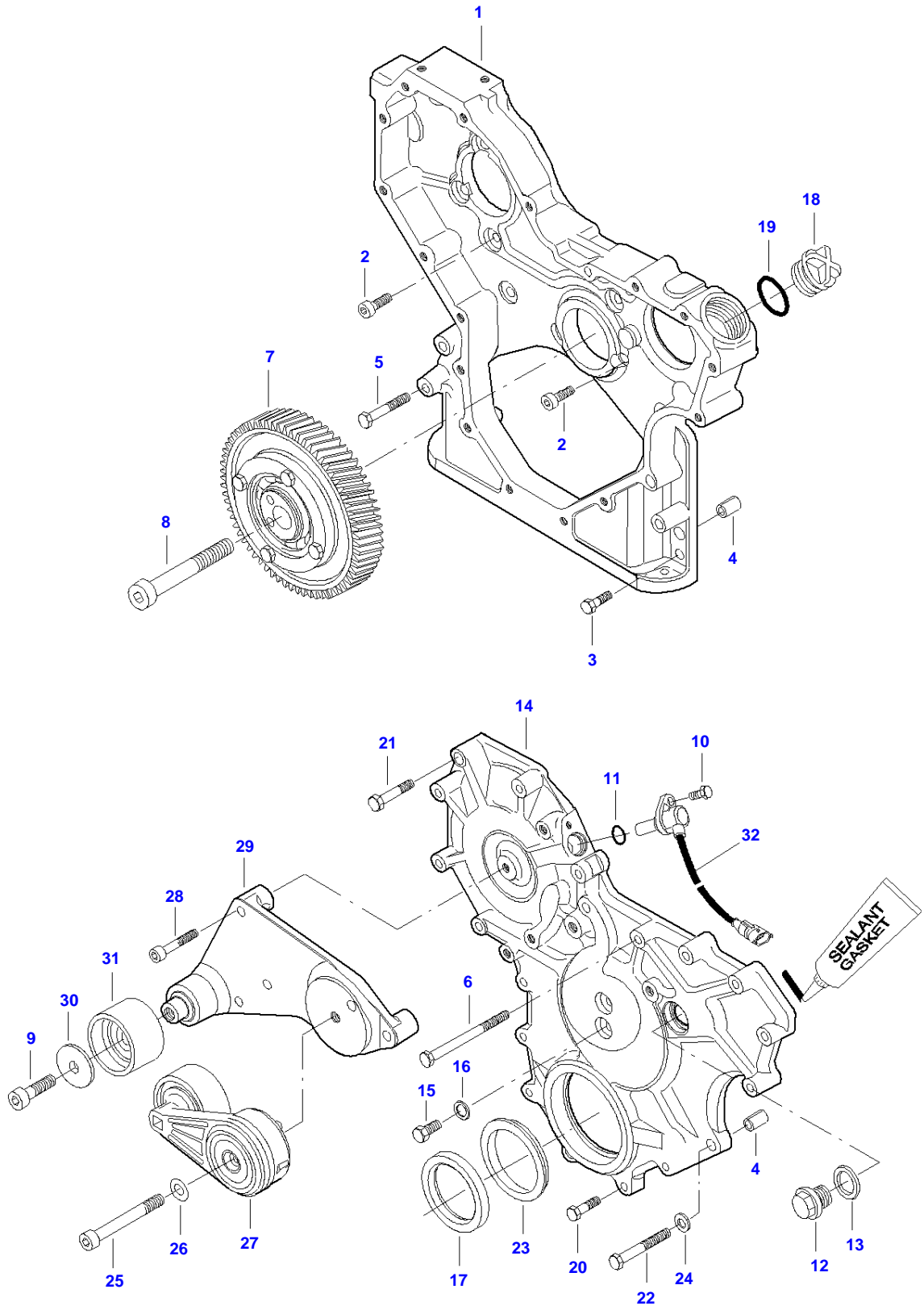

Item	Part Number	Qty	Description Comments
1	V837073565	1	TIMING GEAR CASE
2	V581804600	10	HEX SOCKET SCREW M8 X 20
3	V528801400	2	HEX CAP SCREW M8 X 25
4	V598359850	3	PIN
5	V529801470	3	HEX CAP SCREW M8 X 60
6	V529801540	1	HEX CAP SCREW M8 X 95
7	V837073583	1	IDLER GEAR
8	V581705910	1	HEX SOCKET SCREW M14 X 70
9	V581705430	1	HEX SOCKET SCREW M12 X 30
10	V528801062	1	HEX CAP SCREW M6 X 16
11	V614601718	1	O-RING
12	V640045022	1	PLUG
13	V615882227	1	SEALING WASHER [A]
14	V837073566	1	GEAR HOUSING FRONT COVER
15	V528801380	2	HEX CAP SCREW M8 X 20
16	V615870814	2	SEALING WASHER [A]
17	V836840883	1	CRANKSHAFT SEAL [A]
	V836873100	X	SPACER THICKNESS 3.00 MM
18	V836017927	1	CAP
19	V614603540	1	O-RING [A]
20	V528801410	6	HEX CAP SCREW M8 X 30
21	V529801440	9	HEX CAP SCREW M8 X 45
22	V529801520	1	HEX CAP SCREW M8 X 85
23	V836855636	1	SHIELD
24	V836120989	1	WASHER
25	V581705130	1	HEX SOCKET SCREW M10 X 80
26	V500951000	1	SPRING WASHER
27	V837073101	1	BELT TENSIONER
28	V581804650	4	HEX SOCKET SCREW M8 X 40
29	V837074489	1	RETAINING PLATE
30	V836866312	1	FLANGE
31	V836866321	1	ROLLER
	V837074402	1	PULLEY, IDLER [B]
32		1	SPEED SENSOR SEE PAGE 01-0025 [A] INCLUDED IN GASKET SET FOR ENGINE [B] TIER2 ENGINE

MF 7614 TRACTOR (DYNA 4)
CRANKSHAFT, PISTONS & PISTON ROD

1-WH02-027-A

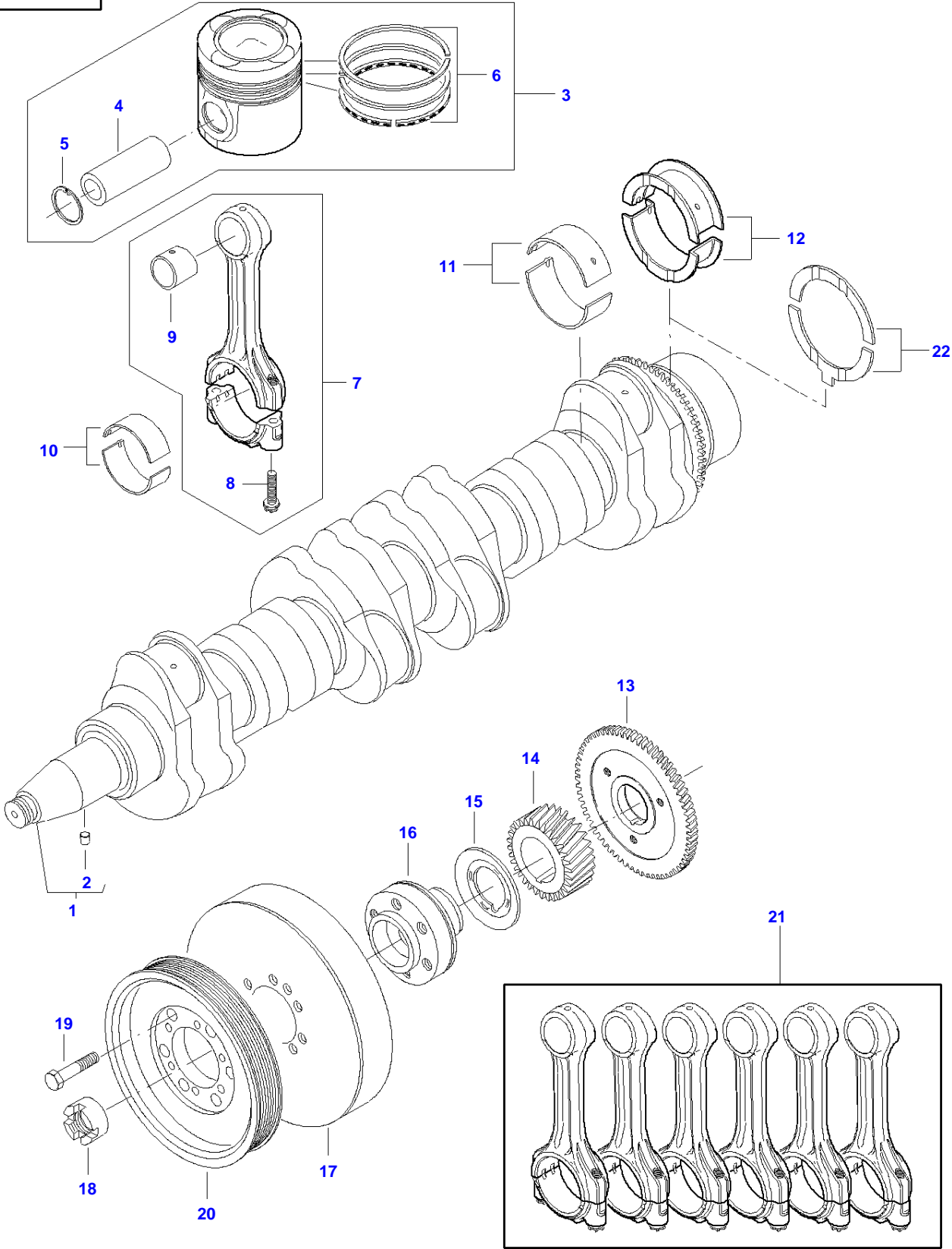

Item	Part Number	Qty	Description Comments
1	V837073983	1	CRANKSHAFT
2	V836867857	1	KEY
3	V837074081	6	PISTON
4		6	(3) PISTON PIN NOT SERVICED,ORDER Ref. 3
5		12	(3) CIRCLIP NOT SERVICED,ORDER Ref. 3
6	V837079460	6	PISTON RING KIT
7		1	(3) KIT, CONROD NOT SERVICED,ORDER Ref. 28
8	V836864141	12	SCREW SPECIAL
9	V836110646	6	BEARING BUSH
10	V836110552	6	CONROD BEARING STANDARD 67.981-68.000 MM
	V836112762	X	BEARING SHELL 67.731-67.750 MM
	V836112763	X	BEARING SHELL 67.481-67.500 MM
	V836112765	X	CONROD BEARING 66.981-67.000 MM
	V836112767	X	CONROD BEARING 66.481-66.500 MM
11	V836840944	6	MAIN BEARING STANDARD n?1 ... 6 89.985-90.020 MM
	V836840978	X	MAIN BEARING N?1 ... 7 89.735-89.770 MM
	V836840979	X	MAIN BEARING N?1 ... 7 89.485-89.520 MM
	V836840980	X	MAIN BEARING N?1 ... 7 88.985-89.020 MM
	V836840981	X	MAIN BEARING N?1 ... 7 88.485-88.520 MM
12	V836879152	1	MAIN BEARING STANDARD N?7 89.985-90.020 MM
13	V836674069	1	GEAR,CRANKSHAFT
14	V837073560	1	GEAR,CRANKSHAFT
15	V836855637	1	RING
16	V837070178	1	CRANKSHAFT HUB
	V837073678	1	CRANKSHAFT HUB [A]
17	V837070177	1	DAMPER
18	V836847641	1	CRANKSHAFT NUT
19	V529702250	6	HEX CAP SCREW M12 X 50
20	V836867660	1	PULLEY
21	V836840928	1	CONNECTING ROD KIT
22	V836840945	X	THRUST WASHER STD
	V836840982	X	THRUST WASHER 0.10 MM

Massey Ferguson

7614 TRACTOR (DYNA 4)

3906400

CRANKSHAFT, PISTONS & PISTON ROD

Page01-0009

Item	Part Number	Qty	Description Comments
22	V836840983	X	THRUST WASHER 0.20 MM [A] TIER2 ENGINE

MF 7614 TRACTOR (DYNA 4) CAMSHAFT & VALVE MECHANISM

1-WH22-006-A

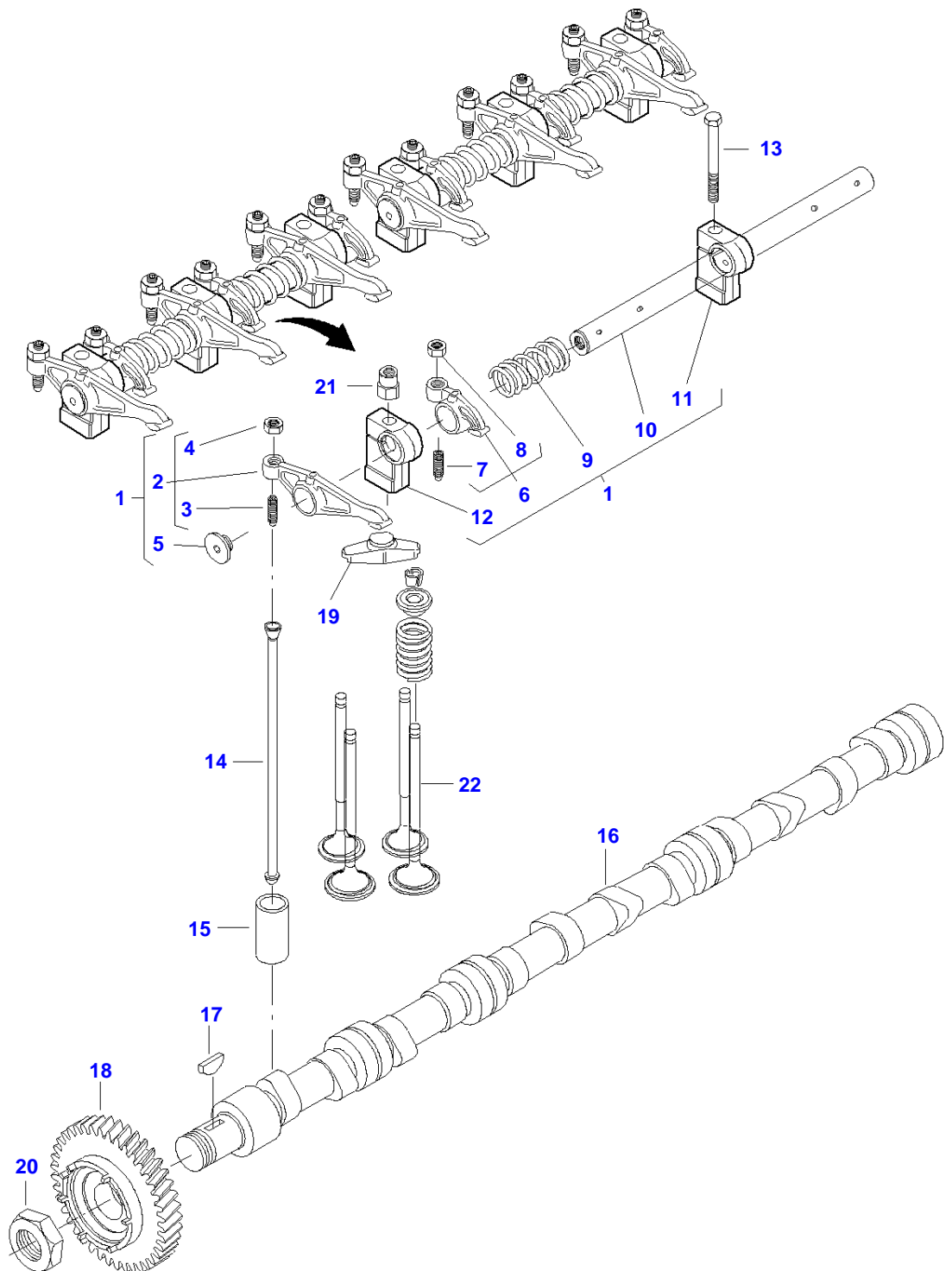

Item	Part Number	Qty	Description Comments
1	V837069016	2	ROCKER SHAFT ASM
2	V837069011	6	ROCKER ARM (1)
3	V837069023	6	VALVE ROCKER ADJUSTMENT SCREW (2)
4	V512861000	6	NUT (2)
5	V837069020	4	PLUG (1)
6	V837069013	6	ROCKER ARM (1)
7	V837069023	6	VALVE ROCKER ADJUSTMENT SCREW (6)
8	V512861000	6	NUT (6)
9	V837069019	4	SPRING (1)
10	V837069015	2	SHAFT (1)
11	V837069018	2	ROCKER SHAFT BRACKET (1)
12	V837069017	4	ROCKER SHAFT BRACKET (1)
13	V529801910	2	HEX CAP SCREW M10 X 80
14	V837070119	12	PUSH ROD
15	V836014264	12	TAPPET
16	V837069101	1	CAMSHAFT
17	V603305760	1	WOODRUFF KEY
18	V837073562	1	GEAR,CAMSHAFT
19	V837073089	12	GUIDE
20	V837069085	1	NUT
21	V836655406	4	HEX NUT
22		1	EXHAUST VALVE SEE PAGE 01-0011

MF 7614 TRACTOR (DYNA 4)
CYLINDER HEAD

1-WH03-025-A

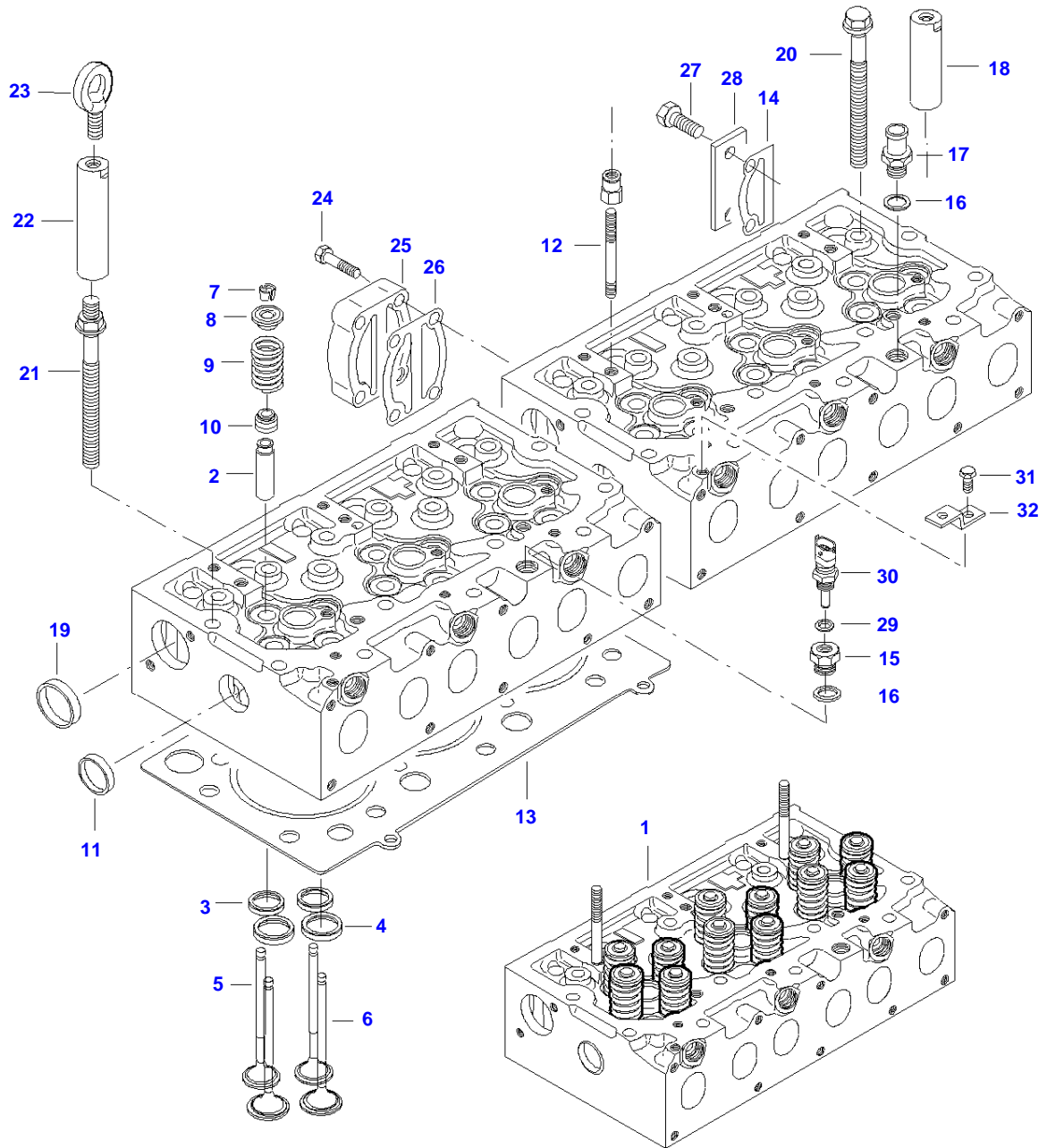

Item	Part Number	Qty	Description Comments
1	V837073233	2	CYLINDER HEAD
2	V837073174	24	VALVE GUIDE (1)
3	V837064907	12	VALVE SEAT (1) [A]
4	V837064908	12	VALVE SEAT (1) [B]
5	V837069002	12	EXHAUST VALVE (1)
6	V837069003	12	INTAKE VALVE (1)
7	V837064910	48	COTTER (1)
8	V837069004	24	SPRING PLATE (1)
9	V837069005	24	VALVE SPRING (1)
10	V837073165	24	VALVE STEM GASKET (1) [D]
11	V836647942	8	PLUG (1)
12	V546801900	4	STUD BOLT (1) M10 X 75
13	V837070290	2	CYLINDER HEAD GASKET [D]
14	V836867753	1	GASKET [D]
15	V836119643	1	THREADED NIPPLE
16	V615881822	2	SEALING WASHER [D]
17	V836119837	1	HOSE COUPLER
18	V836867567	1	LIFTING EYE EXTENSION 86 MM
19	V640016045	2	PLUG
20	V837069025	24	CYLINDER HEAD BOLT
21	V837073571	10	CYLINDER HEAD BOLT
22	V837067791	1	LIFTING EYE EXTENSION 136 MM
23	V836640752	2	LIFT EYE
24	V528801820	4	HEX CAP SCREW M10 X 35
25	V836855348	1	JOINT PIECE
26	V836867752	1	GASKET [D]
27	V528801800	2	HEX CAP SCREW M10 X 25
28	V836855350	1	COVER
29	V615881418	1	SEALING WASHER [D]
30		1	TEMPERAT SENSOR SEE PAGE 01-0025
31	V528801360	1	HEX CAP SCREW M8 X 16
32	V836747849	1	SUPPORT [A] FOR VALVE EXHAUST [B] FOR VALVE INLET [D] INCLUDED IN GASKET SET FOR CYLINDER HEAD

MF 7614 TRACTOR (DYNA 4)
CYLINDER HEAD COVER

1-WH23-015-A

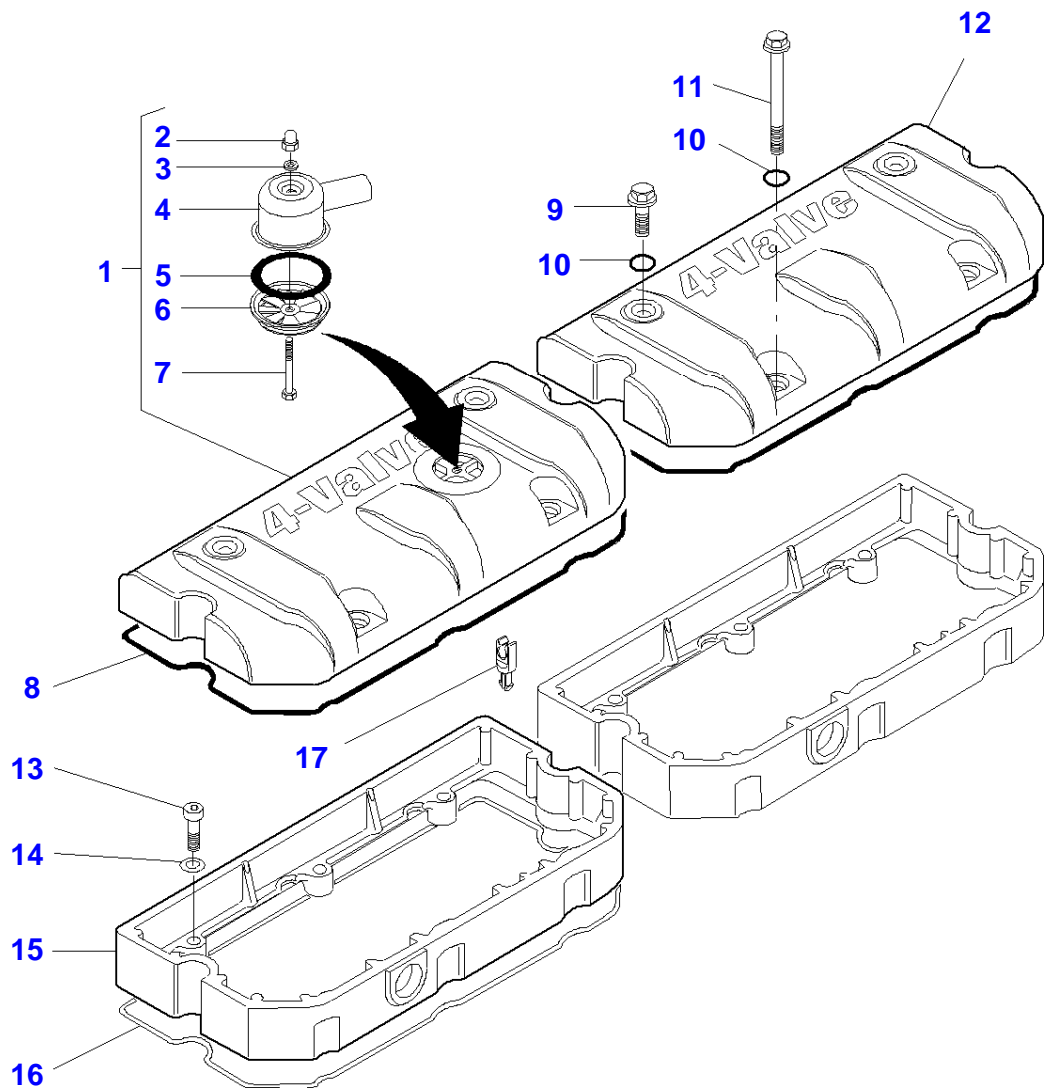

Item	Part Number	Qty	Description Comments
1	V837070452	1	VALVE ROCKER COVER
2	V519600602	1	HEX NUT (1) M6
3	V836667508	1	SEALING WASHER (1)
4	V837070442	1	BREATHER (1)
5	V836667459	1	GASKET (1)
6	V837070443	1	BREATHER (1)
7	V528801172	1	HEX CAP SCREW (1) M6 X 60
8	V837067881	2	VALVE ROCKER COVER GASKET [A]
9	V540801780	4	HEX CAP SCREW M10 X 20
10	V614901030	8	O-RING [A]
11	V540801910	4	SCREW M10 X 80
12	V837069022	1	VALVE ROCKER COVER
13	V581804630	6	HEX SOCKET SCREW M8 X 30
14	V500950800	6	SPRING WASHER
15	V837073888	2	VALVE ROCKER COVER FRAME
16	V837067881	2	VALVE ROCKER COVER GASKET [A]
17	V837073227	4	BAND [A] INCLUDED IN GASKET SET FOR CYLINDER HEAD

MF 7614 TRACTOR (DYNA 4)
CYLINDER HEAD COVER

1-WH23-016-A

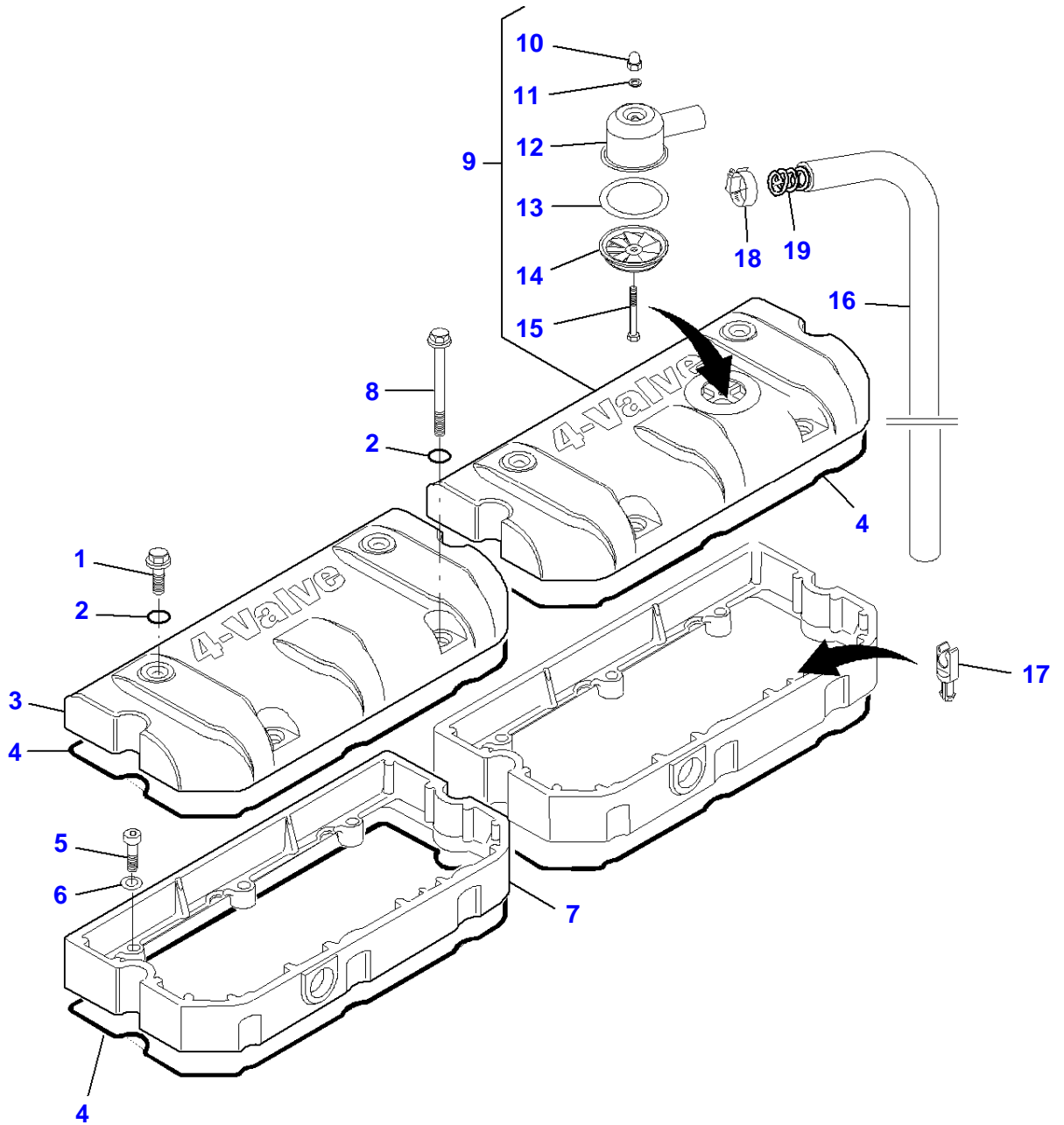

Item	Part Number	Qty	Description Comments
1	V540801780	4	HEX CAP SCREW M10 X 20
2	V614901030	8	O-RING [A]
3	V837069022	1	VALVE ROCKER COVER
4	V837067881	4	VALVE ROCKER COVER GASKET [A]
5	V581804630	6	HEX SOCKET SCREW M8 X 30
6	V500950800	6	SPRING WASHER
7	V837073888	2	VALVE ROCKER COVER FRAME
8	V540801910	4	SCREW M10 X 80
9	V837070452	1	VALVE ROCKER COVER
10	V519600602	1	HEX NUT (9) M6
11	V836667508	1	SEALING WASHER (9)
12	V837070442	1	BREATHER (9)
13	V836667459	1	GASKET (9)
14	V837070443	1	BREATHER (9)
15	V528801172	1	HEX CAP SCREW (9) M6 X 60
16	V837070346	1	RUBBER HOSE 1150 MM
17	V837073227	4	BAND
18	V602078532	1	HOSE CLIP
19	V837070343	1	SPRING [A] INCLUDED IN GASKET SET FOR CYLINDER HEAD

MF 7614 TRACTOR (DYNA 4)
OIL SUMP

1-WH11-018-A

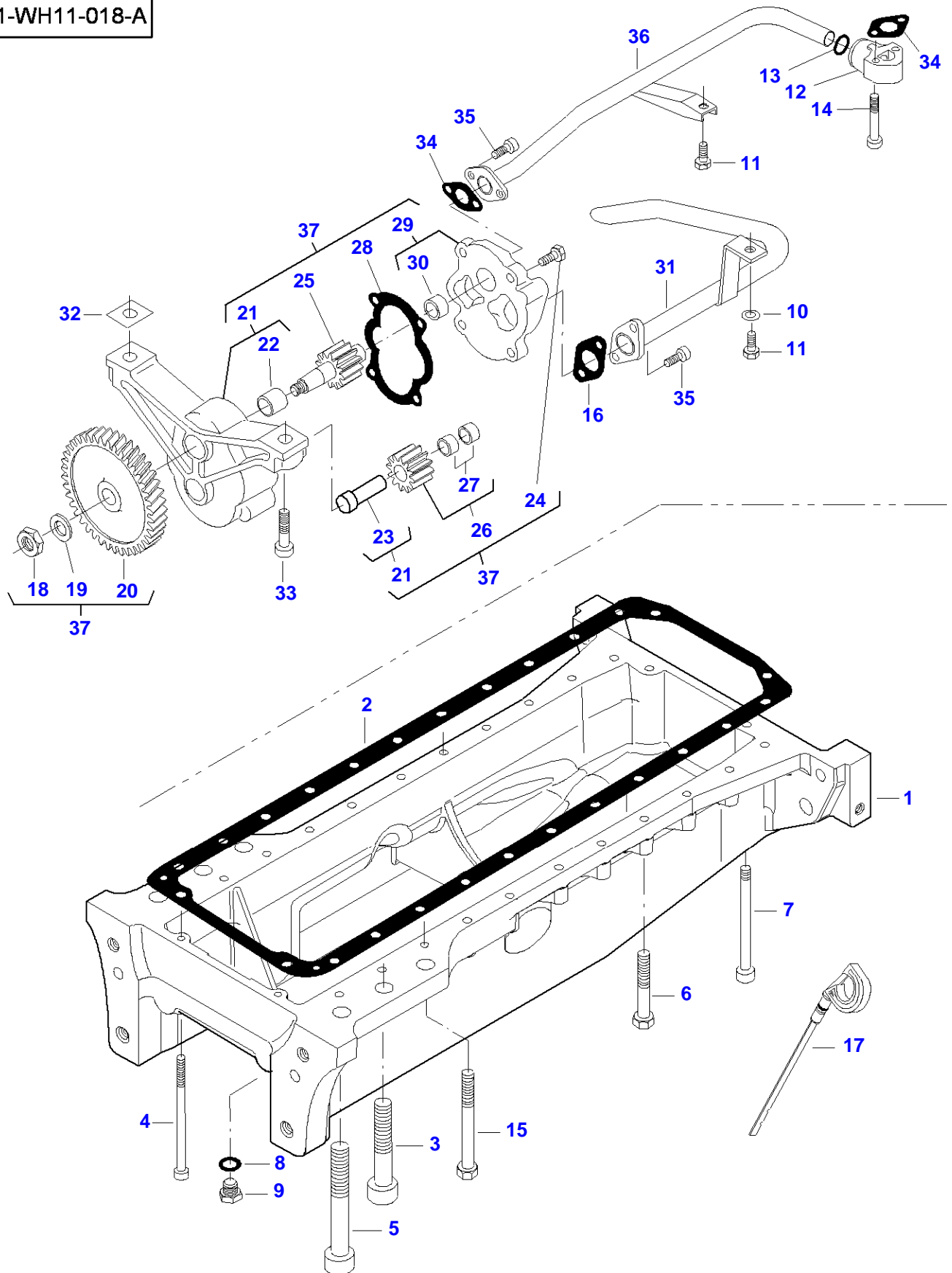

Item	Part Number	Qty	Description Comments
1	V836873817	1	OIL SUMP
2	V836322183	1	OIL SUMP GASKET [C]
3	V581706750	4	HEX SOCKET SCREW M20 X 90
4	V581704830	2	HEX SOCKET SCREW M8 X 160
	V581704834	2	HEX SOCKET SCREW M8 X 160 [B]
5	V581706790	2	HEX SOCKET SCREW M20 X 120
6	V529701880	16	HEX CAP SCREW M10 X 65
7	V581705210	2	HEX SOCKET SCREW M10 X 140
8	V615881827	1	SEALING WASHER [C]
9	V836655493	1	PLUG M18
10	V500150840	1	FLAT WASHER
11	V528801362	2	HEX CAP SCREW M8 X 16
12	V836866563	1	CONNECTOR
13	V614702230	1	O-RING
14	V581804680	2	HEX SOCKET SCREW M8 X 55
15	V581705180	6	HEX SOCKET SCREW M10 X 110
16	V836338201	1	GASKET [C]
17	V836666908	1	DIPSTICK
18	V504861000	1	NUT (37) M10
19	V836122910	1	WASHER (37)
20	V836338667	1	GEAR (37)
21	V836338186	1	FRAME (37)
22	V836322909	1	BUSHING (21)
23	V836322906	1	OIL PUMP SHAFT (21)
24	V528801380	4	HEX CAP SCREW (37) M8 X 20
25	V836338182	1	SHAFT (37)
26	V836338180	1	GEAR,OIL PUMP (37)
27	V836322909	2	BUSHING (26)
28	V836338188	1	GASKET (37) [C]
29	V836855297	1	COVER (37)
30	V836322909	1	BUSHING (29)
31	V836873818	1	OIL PUMP SUCTION PIPE
32	V836007871	X	SHIM
33	V581805050	2	HEX SOCKET SCREW M10 X 40
34	V836008449	2	GASKET [C]
35	V581804602	4	HEX SOCKET SCREW M8 X 20
36	V836866569	1	OIL PIPE
37	V836855300	1	LUBRICATING OIL PUMP

Massey Ferguson

7614 TRACTOR (DYNA 4)

3906400

OIL SUMP

Page01-0014

Item	Part Number	Qty	Description
			Comments
			[B] TIER2 ENGINE
			[C] INCLUDED IN GASKET SET FOR ENGINE

MF 7614 TRACTOR (DYNA 4)
OIL COOLER & FILTER

1-WH26-010-A

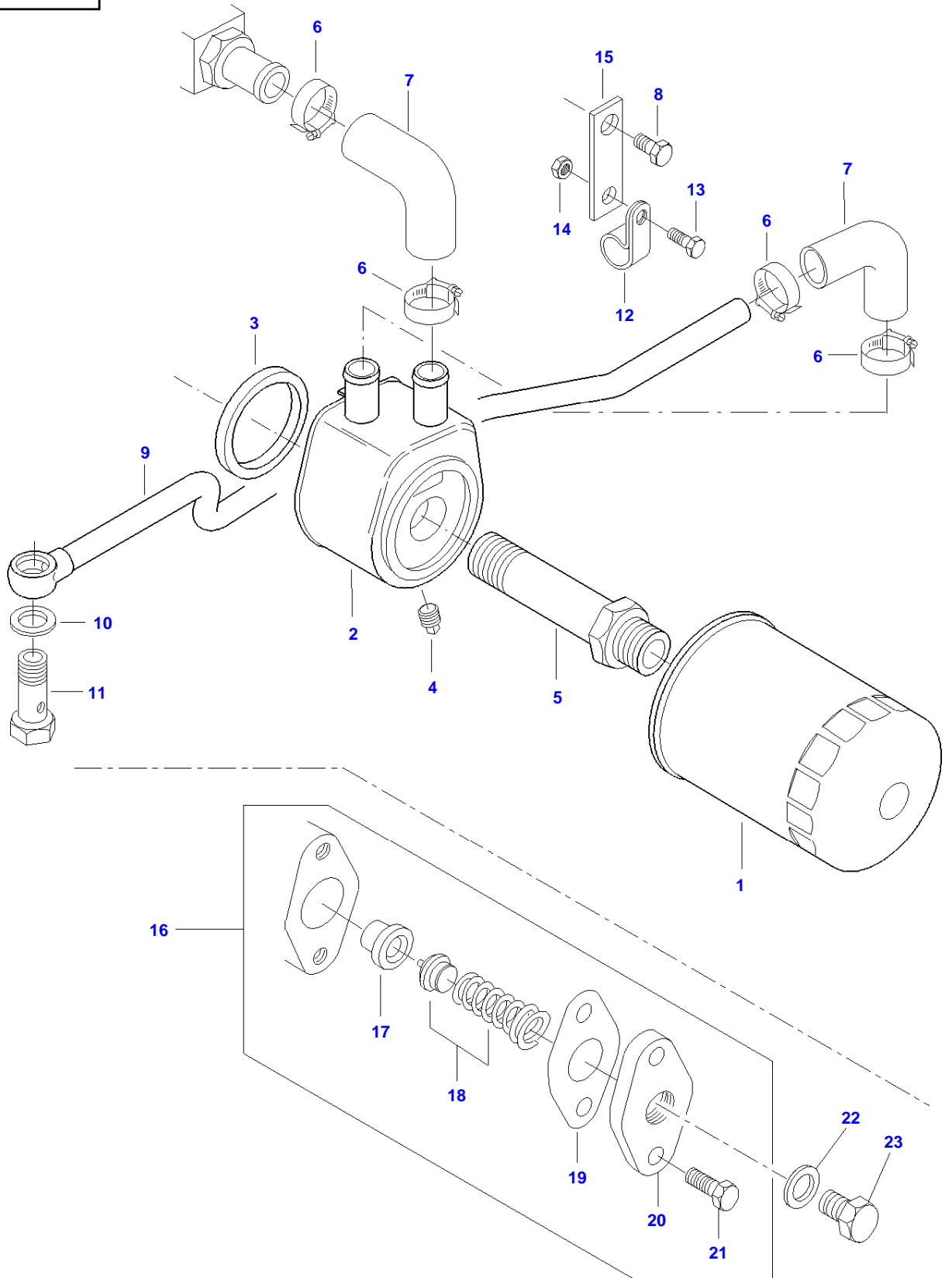

Item	Part Number	Qty	Description Comments
1	V836679586	1	OIL FILTER
2	V836859699	1	OIL COOLER
3	V836862235	1	SEALING WASHER (2)
4	V640004004	1	PLUG (2)
5	V836859700	1	UNION
6	V602079516	4	HOSE CLIP
7	V836859899	2	RUBBER ELBOW
8	V528801760	1	HEX CAP SCREW M10 X 16
9	V837070173	1	PIPE
10	V615881822	2	SEALING WASHER [B]
11	V640435015	1	BANJO BOLT
12	V602074615	1	HOSE CLIP
13	V528801380	1	HEX CAP SCREW M8 X 20
14	V504800800	1	HEX NUT M8
15	V837070143	1	SUPPORT
16	V837079484	1	REGULATING VALVE
17	V836659521	1	VALVE SEAT (16)
18	V836667650	1	SPRING ASSEMBLY (16)
19	V836322190	1	GASKET (16) [B]
20	V837074289	1	COVER (16)
21	V528801380	2	HEX CAP SCREW (16) M8 X 20
22	V615881420	1	SEALING WASHER [A][B]
23	V640305014	1	PLUG [A] [A] TIER2 ENGINE [B] INCLUDED IN GASKET SET FOR ENGINE

MF 7614 TRACTOR (DYNA 4)
ENGINE BREATHER

1-WH31-002-A

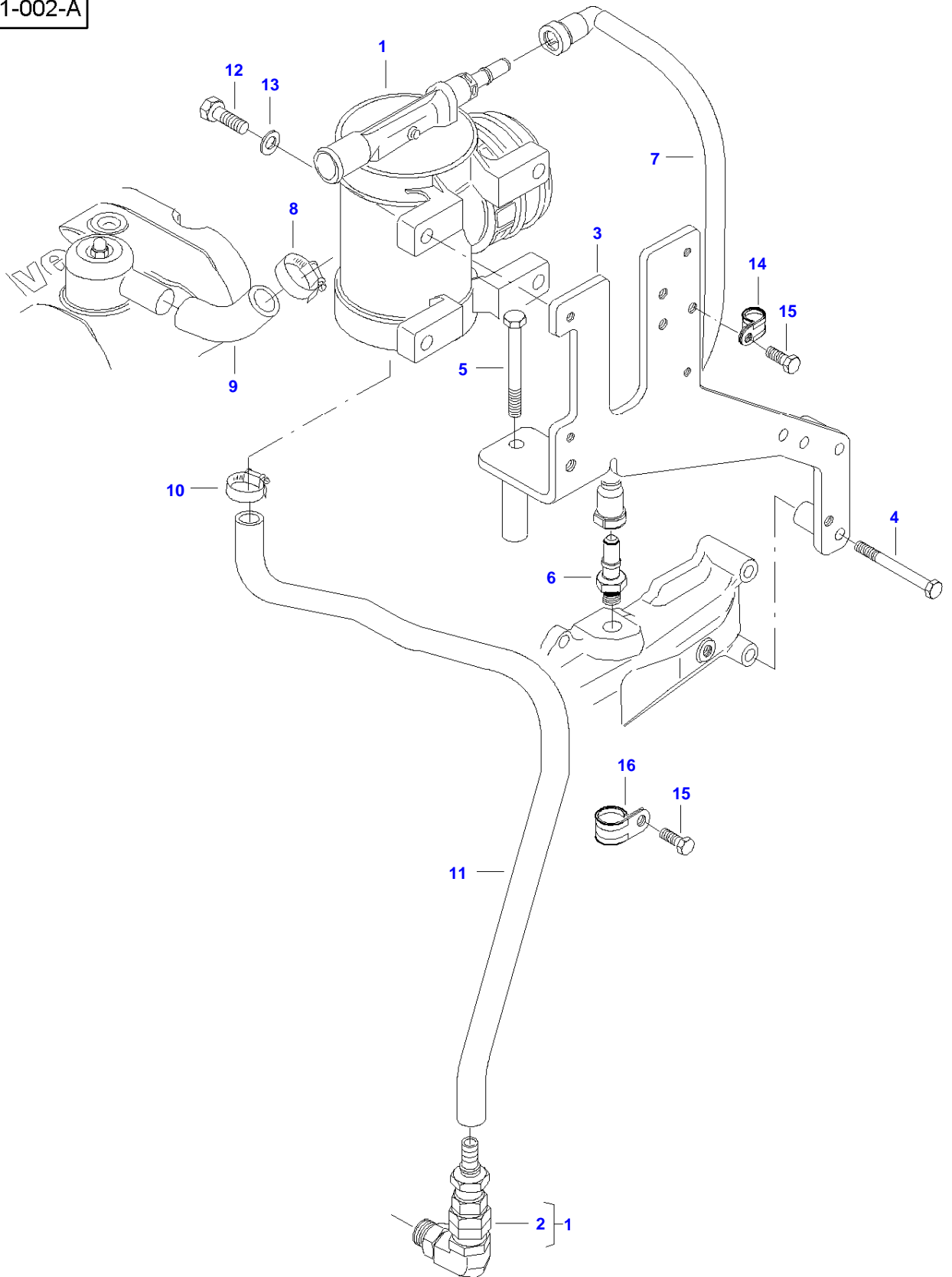



Suggest:

For more complete manuals. Please go to the home page.

<https://www.ebooklibonline.com>

If the above button click is invalid. Please download this document first, and then click the above link to download the complete manual.

Thank you so much for reading

Item	Part Number	Qty	Description Comments
1	V837074160	1	CCV FILTER
2	V837074234	1	CHECK VALVE (1)
3	V837074328	1	BRACKET
4	V529801550	2	HEX CAP SCREW M8 X 100
5	V529801950	1	HEX CAP SCREW M10 X 100
6	V837067936	1	QUICK COUPLER 7/16"
7	V837074303	1	HOSE
8	V602090544	2	HOSE CLIP
9	V837074038	1	RUBBER HOSE
10	V602087528	2	HOSE CLIP
11	V837074329	1	HOSE
12	V581804630	4	HEX SOCKET SCREW M8 X 30
13	V500150842	4	WASHER
14	V602060615	1	HOSE CLIP
15	V528801360	2	HEX CAP SCREW M8 X 16
16	V602074522	1	HOSE CLIP

MF 7614 TRACTOR (DYNA 4)
WATER PUMP

1-WH28-022-A

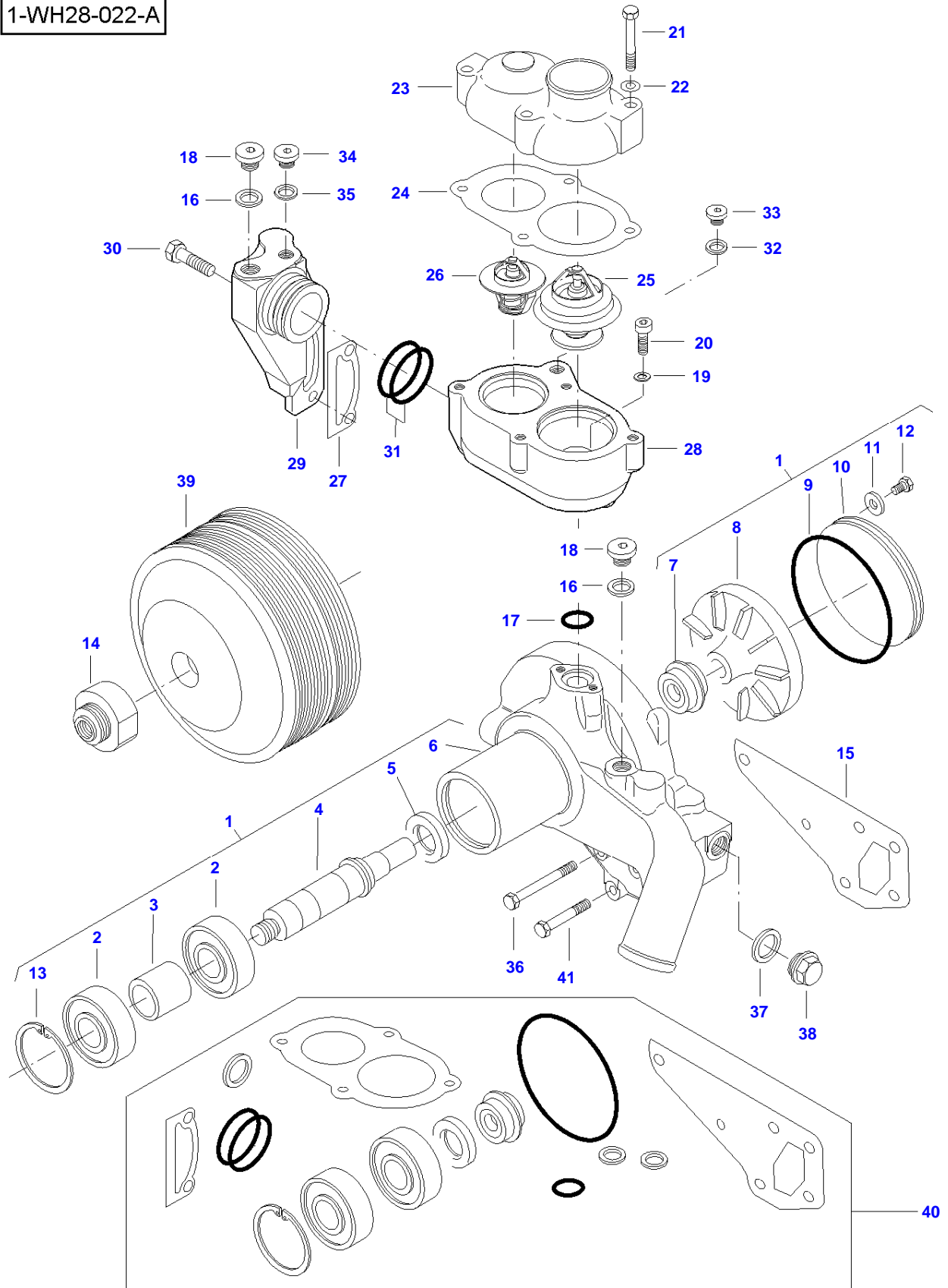

<https://www.ebooklibonline.com>

Hello dear friend!

Thank you very much for reading.

Enter the link into your browser.

The full manual is available for immediate download.

<https://www.ebooklibonline.com>