

<b>Page Number</b>	<b>Page Title</b>	<b>Page Reference</b>
01-000-TOC	ENGINE ACW1606290 33 AWFC	01-000-TOC
02-000-TOC	ENGINE INSTALLATION	02-000-TOC
03-000-TOC	AXLES	03-000-TOC
04-000-TOC	STEERING SYSTEM	04-000-TOC
05-000-TOC	DRIVE TRAIN SYSTEM	05-000-TOC
06-000-TOC	BRAKE SYSTEM	06-000-TOC
07-000-TOC	COMPRESSED AIR SYSTEM	07-000-TOC
08-000-TOC	HYDRAULIC SYSTEM	08-000-TOC
09-000-TOC	ELECTRICAL SYSTEM	09-000-TOC
10-000-TOC	CAB	10-000-TOC
11-000-TOC	CHASSIS	11-000-TOC
12-000-TOC	DECALS	12-000-TOC
13-000-TOC	WHEELS	13-000-TOC
14-000-TOC	IMPLEMENT DRIVE SYSTEM	14-000-TOC
15-000-TOC	IMPLEMENT LIFT SYSTEM REAR	15-000-TOC
16-000-TOC	LINKAGE	16-000-TOC
17-000-TOC	FRONT/REAR LOADERS	17-000-TOC
18-000-TOC	ACCESSORIES	18-000-TOC
19-000-TOC	GENERAL INFORMATION	19-000-TOC



<b>Item</b>	<b>Part Number</b>	<b>Qty</b>	<b>Description Comments</b>	<b>Technical Specification</b>
1	ACW1606290	1	ENGINE	33 AWFC
2	ACW1668960	1	SHORT BLOCK ENGINE	33 AWIC/AWFC
3	V837079921	1	LABEL ENGINE TYPE PLATE	

**<https://www.ebooklibonline.com>**

Hello dear friend!

Thank you very much for reading.

Enter the link into your browser.

The full manual is available for immediate download.

**<https://www.ebooklibonline.com>**

MF 5709 DYNA 4 TRACTOR ( ECO3 / TIER 4F )  
AP112359

AP112359

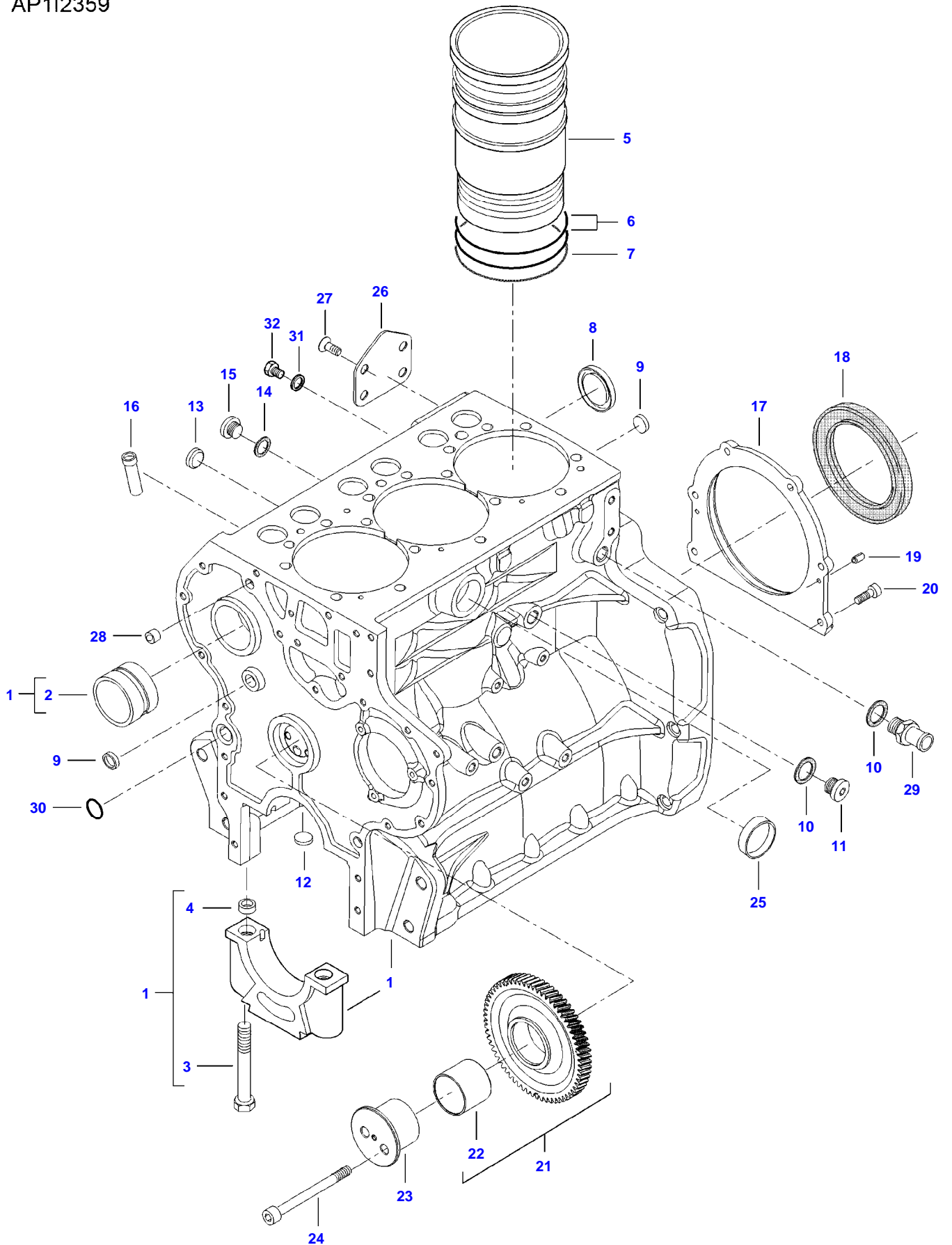

Item	Part Number	Qty	Description Comments
1	V837081001	1	CYLINDER-BLOCK
2	V836866069	1	CAMSHAFT BEARING BUSH (1)
3	V837081037	8	HEX CAP SCREW (1)
4	V837081041	8	GUIDE SLEEVE (1)
5	V837081031	3	LINER
6	V836647502	6	CYLINDER LINER O-RING [B]
7	V836647503	3	CYLINDER LINER O-RING [B]
8	V837081133	1	PLUG
9	V640016016	2	PLUG
10	V615881824	2	SEALING WASHER [B]
11	V640325018	1	PLUG
12	V640016020	1	PLUG
13	V640016018	1	PLUG
14	V615871014	2	SEALING WASHER [B]
15	V640325110	2	PLUG
16	V837081103	1	PIPE
17	V837081321	1	COVER
18	V837081286	1	CRANKSHAFT SEAL [B]
19	V595959140	2	PIN
20	V581804580	6	HEX SOCKET SCREW
21	V837081084	1	IDLER GEAR
22	V837081019	1	BUSH (21)
23	V837081017	1	SHAFT
24	V581705100	2	HEX SOCKET SCREW
25	V640016040	1	PLUG
26	V837081427	1	COVER
27	V579804602	4	HEX SOCKET SCREW
28	V598359850	2	PIN
29	V837081395	1	HOSE COUPLER
30	V614602030	1	O-RING [B]
31	V615870812	1	SEALING WASHER [B]
32	V528801342	1	HEX CAP SCREW [B] INCLUDED IN COMPLETE ENGINE GASKET KIT 2

MF 5709 DYNA 4 TRACTOR ( ECO3 / TIER 4F )  
AP2A1598

AP2A1598

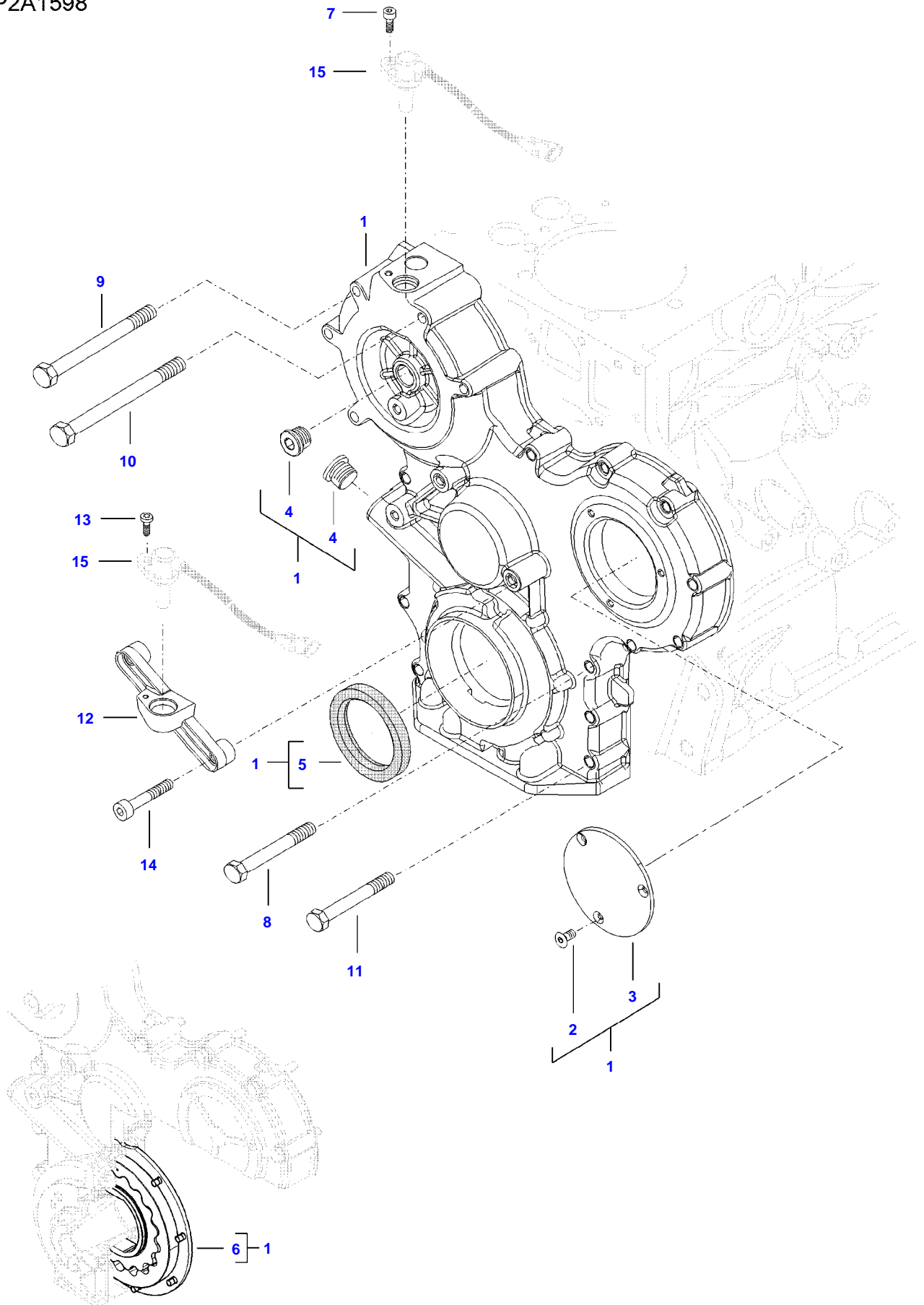

Item	Part Number	Qty	Description Comments
1	V837081039	1	TIMING GEAR CASE
2	V579904162	3	HEX SOCKET SCREW (1)
3	V837081057	1	COVER (1)
4	V640325120	2	PLUG (1)
5	V836840883	1	CRANKSHAFT SEAL (1) [B]
6		1	NOT AVAILABLE AS SINGLE PART (1)
7	V581804182	1	HEX SOCKET SCREW
8	V540801470	1	HEXAGON FLANGE BOLT
9	V540801490	4	HEXAGON FLANGE BOLT
10	V540801510	1	HEXAGON FLANGE BOLT
11	V540801450	12	HEXAGON FLANGE BOLT
12	V837081375	1	SPEED SENSOR SUPPORT
13	V590253388	1	SCREW
14	V577804620	2	HEX SOCKET SCREW
15		2	SEE PAGE 01-0015 [B] INCLUDED IN COMPLETE ENGINE GASKET KIT 2

MF 5709 DYNA 4 TRACTOR ( ECO3 / TIER 4F )  
AP4A2188

AP4A2188

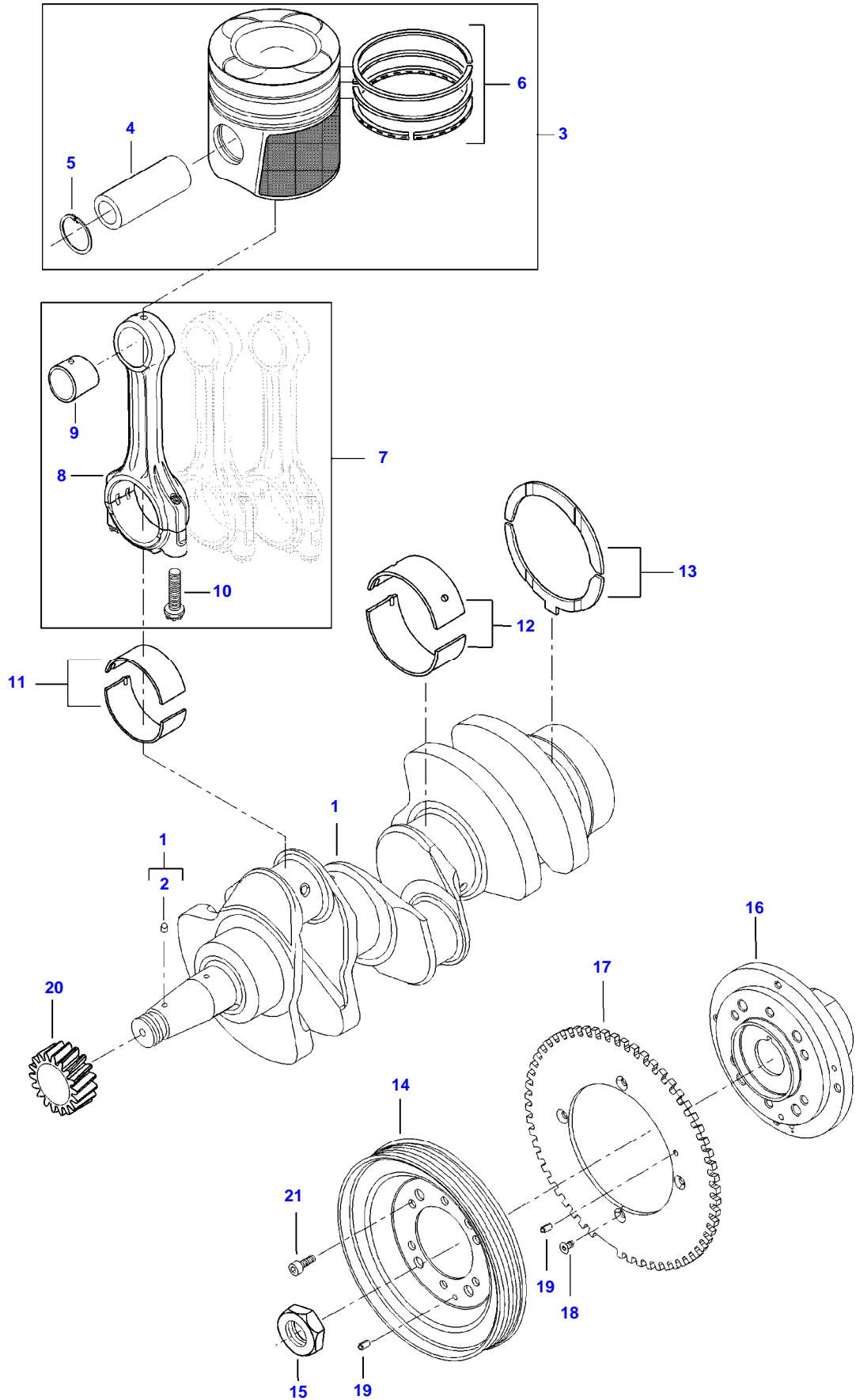

Item	Part Number	Qty	Description Comments
1	V837081002	1	CRANKSHAFT
2	V837081240	2	KEY
3	V837086493	3	(1) PISTON
4		3	NOT AVAILABLE AS SINGLE PART (3)
5		6	NOT AVAILABLE AS SINGLE PART (3)
6	V837079460	3	PISTON RING KIT (3)
7	V837079659	1	CONNECTING ROD KIT
8		3	NOT AVAILABLE AS SINGLE PART (7)
9	V837081025	3	BUSH (7),(8)
10	V837081024	6	CONNECTING ROD BOLT (7),(8)
11	V837091164	3	CONROD BEARING
12	V836655514	4	MAIN BEARING
13	V836119459	2	THRUST WASHER
14	V837086460	1	CRANKSHAFT PULLEY
15	V837081149	1	NUT
16	V837081051	1	CRANKSHAFT HUB
17	V837081059	1	GEAR
18	V579904160	4	HEX SOCKET SCREW
19	V595953360	2	PIN
20	V837081012	1	GEAR,CRANKSHAFT
21	V581804602	6	HEX SOCKET SCREW

AP5A2165

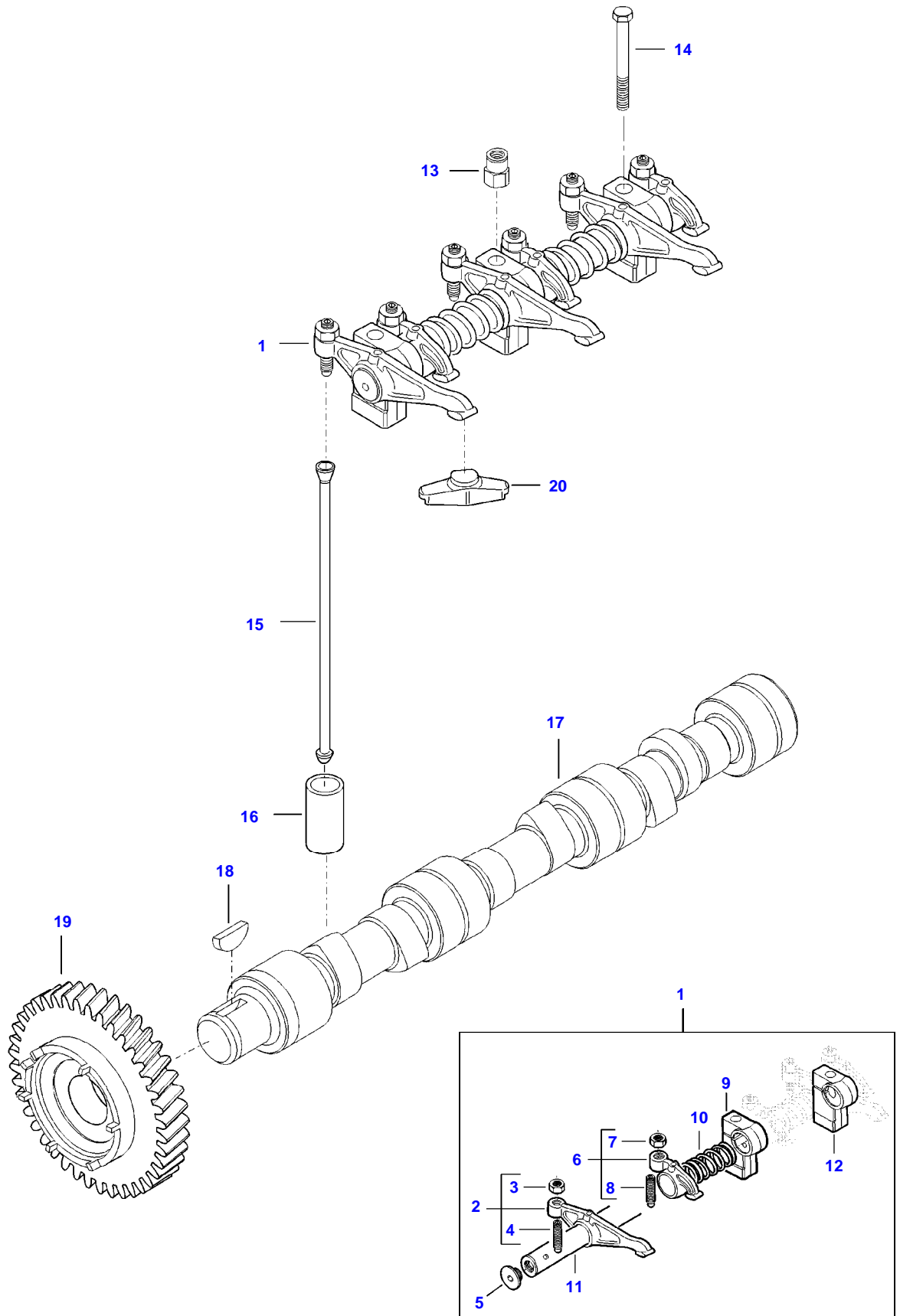

Item	Part Number	Qty	Description Comments
1	V837069016	1	ROCKER SHAFT ASM
2	V837069011	3	ROCKER ARM (1)
3	V512861000	3	NUT (1),(2)
4	V837069023	3	VALVE ROCKER ADJUSTMENT SCREW (1),(2)
5	V837069020	2	PLUG (1)
6	V837069013	3	ROCKER ARM (1)
7	V512861000	3	NUT (1),(6)
8	V837069023	3	VALVE ROCKER ADJUSTMENT SCREW (1),(6)
9	V837069018	1	ROCKER SHAFT BRACKET (1)
10	V837069019	2	SPRING (1)
11	V837069015	1	SHAFT (1)
12	V837069017	2	ROCKER SHAFT BRACKET (1)
13	V836655406	2	NUT
14	V529801910	1	HEX CAP SCREW
15	V837084891	6	PUSHROD
16	V836014264	6	TAPPET
17	V837081128	1	CAMSHAFT
18	V603305760	1	WOODRUFF KEY
19	V837081299	1	GEAR,CAMSHAFT
20	V837073089	6	VALVE BRIDGE

MF 5709 DYNA 4 TRACTOR ( ECO3 / TIER 4F )  
AP6I2357

AP6I2357

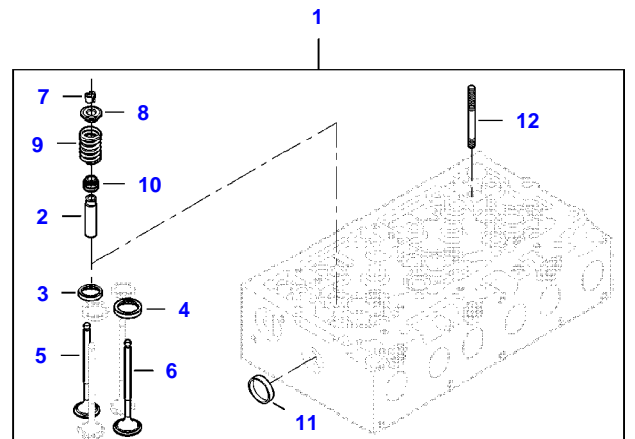
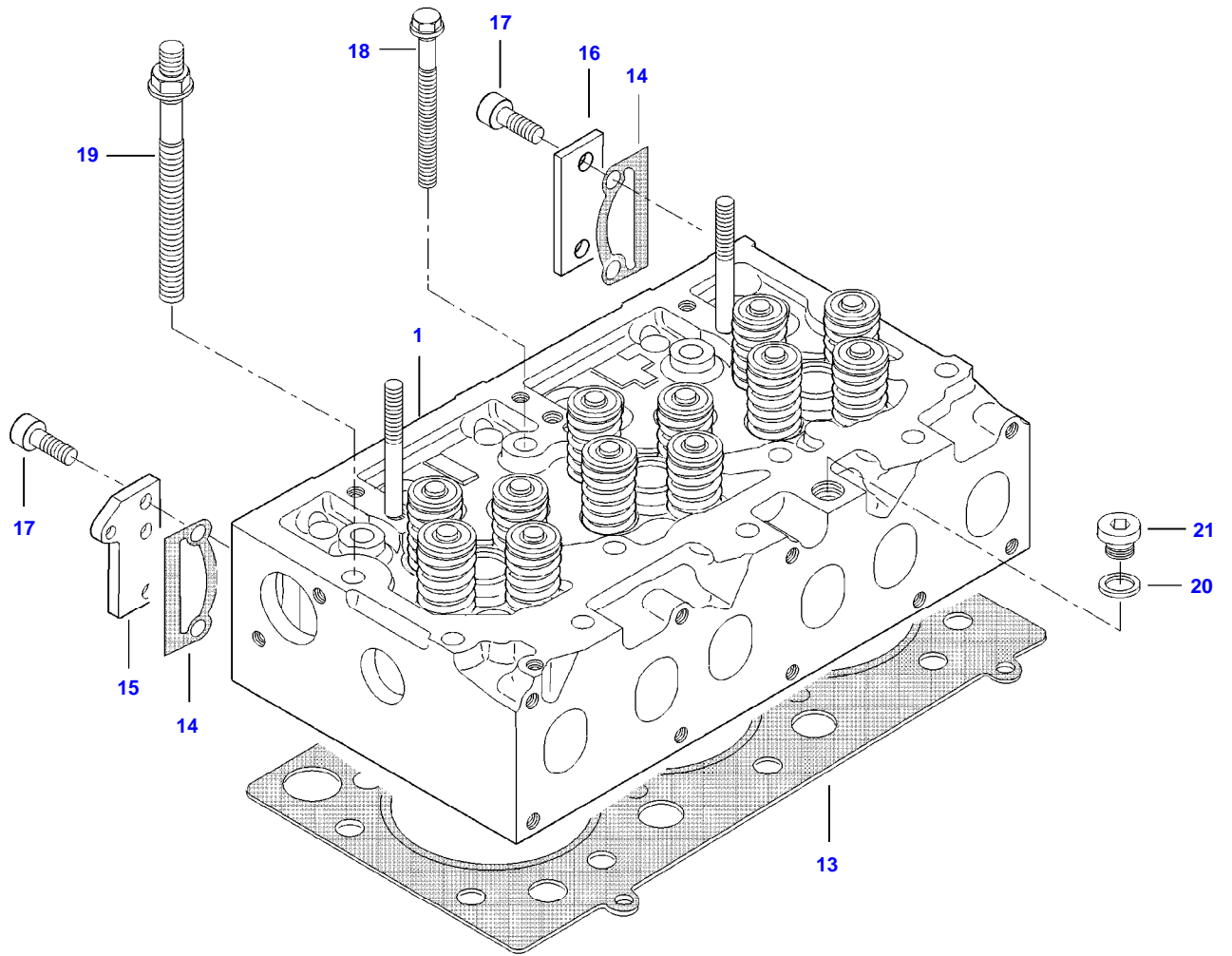

Item	Part Number	Qty	Description Comments
1	V837073941	1	CYLINDER HEAD
2	V837073174	12	VALVE GUIDE (1)
3	V837064907	6	VALVE SEAT (1)
4	V837064908	6	VALVE SEAT (1)
5	V837069002	6	EXHAUST VALVE (1)
6	V837069003	6	INTAKE VALVE (1)
7	V837064910	24	COTTER (1)
8	V837069004	12	SPRING PLATE (1)
9	V837069005	12	VALVE SPRING (1)
10	V837073165	12	VALVE STEM GASKET (1) [A]
11	V836647942	4	PLUG (1)
12	ACW4034880	2	STUD BOLT (1)
13	V837084523	1	CYLINDER HEAD GASKET [A]
14	V836867753	2	GASKET [A]
15	V837084809	1	COVER
16	V836855350	1	COVER
17	V581805000	4	HEX SOCKET SCREW
18	V837069025	10	CYLINDER HEAD BOLT
19	V837073571	7	CYLINDER HEAD BOLT
20	V615881824	1	SEALING WASHER [A]
21	V640325018	1	PLUG [A] INCLUDED IN CYLINDER HEAD GASKET KIT 1

MF 5709 DYNA 4 TRACTOR ( ECO3 / TIER 4F )  
AP35I2339

AP35I2339

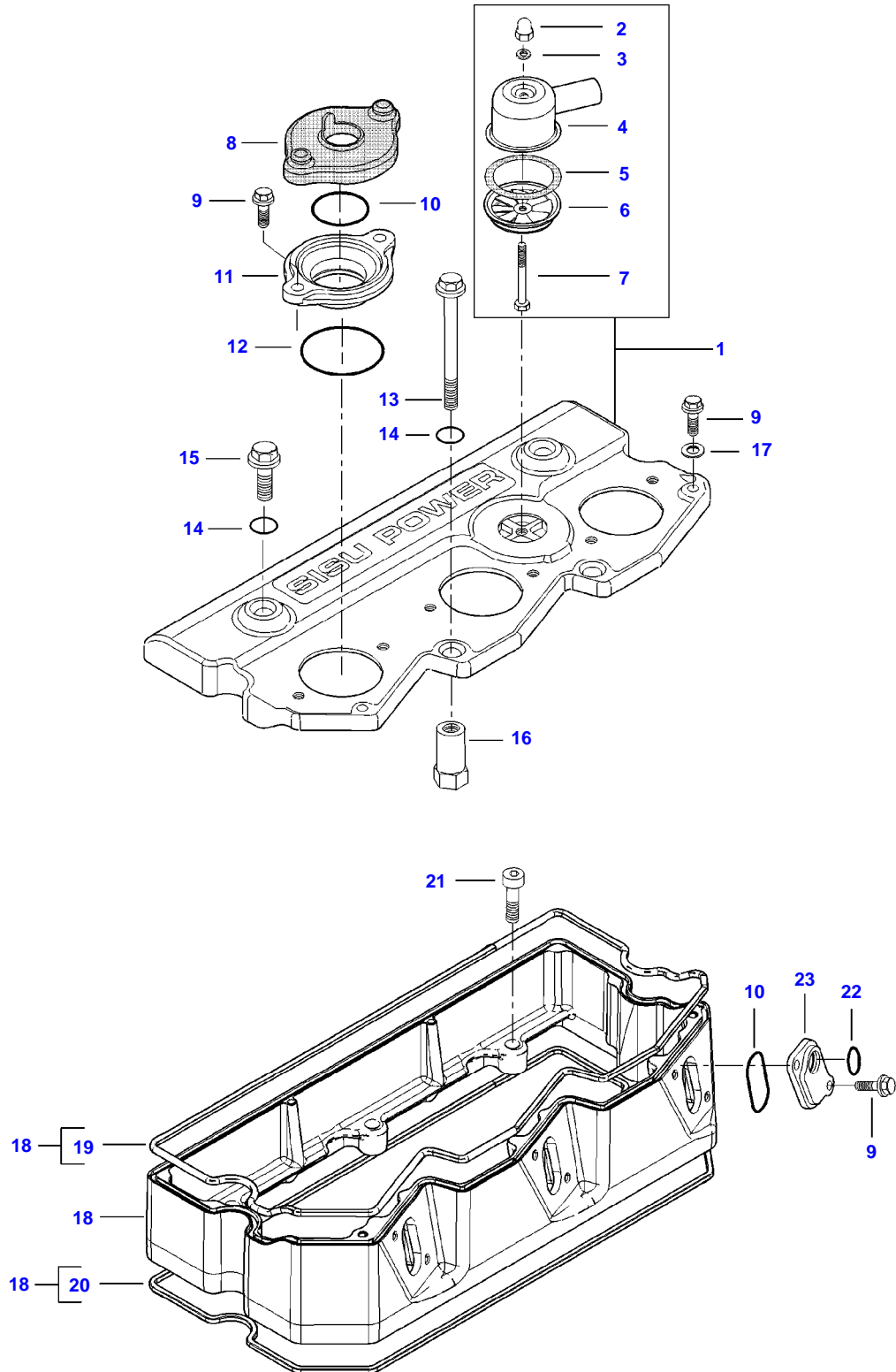

Item	Part Number	Qty	Description Comments
1	V837073755	1	VALVE ROCKER COVER
2	V519600602	1	NUT (1)
3	V836667508	1	SEALING WASHER (1)
4	V837070442	1	BREATHER (1)
5	V836667459	1	GASKET (1)
6	V837070443	1	BREATHER (1)
7	V528801172	1	HEX CAP SCREW (1)
8	V837073756	3	COVER [A][C]
9	V540801082	14	HEXAGON FLANGE BOLT
10	V614903725	6	O-RING [A][C]
11	V837073753	3	FLANGE
12	V614606230	3	O-RING [A][C]
13	V540801852	2	HEXAGON FLANGE BOLT
14	V614901030	4	O-RING [A][C]
15	V540801780	2	HEXAGON FLANGE BOLT
16	V837073903	2	ADAPTER
17	V836667508	2	SEALING WASHER [A][C]
18	V837084245	1	VALVE ROCKER COVER FRAME
19	V837073749	1	VALVE ROCKER COVER GASKET (18) [A][C]
20	V837067881	1	VALVE ROCKER COVER GASKET (18) [A]
21	V581804630	3	HEX SOCKET SCREW
22	V614901725	3	O-RING [A]
23	V837073754	3	FLANGE [A] INCLUDED IN CYLINDER HEAD GASKET KIT 1 [C] INCLUDED IN VALVE ADJUSTING GASKET KIT 3



Item	Part Number	Qty	Description Comments
1	V837081042	1	INTAKE MANIFOLD
2	V837069009	1	INTAKE MANIFOLD GASKET [A]
3	V529801470	5	HEX CAP SCREW
4	V837081468	1	CABLE CLAMP
5	V546801490	2	STUD BOLT
6	V504800800	2	NUT
7	V529801490	2	HEX CAP SCREW
8	V581804602	2	HEX SOCKET SCREW
9	V581804182	3	HEX SOCKET SCREW
10	V640016016	1	PLUG
11	V836666074	2	GASKET [A]
12	V836666073	1	INTAKE AIR PREHEATER
13	V836866713	1	WIRE
14	V504600602	1	NUT
15	V837081480	1	AIR PIPE
16	V837081193	1	PLATE
17	V581705070	2	HEX SOCKET SCREW
18	V528801052	1	HEX CAP SCREW
19	V837084473	1	THROTTLE FLAP
20	V837079937	2	GASKET (19) [A]
21	V837084187	1	AIR PIPE
22	V581804710	4	HEX SOCKET SCREW
23	V500050642	2	WASHER
24	V837081217	1	SUPPORT
25	V837067936	1	QUICK COUPLER
26		1	SEE PAGE 01-0015
27		1	SEE PAGE 01-0015 [A] INCLUDED IN CYLINDER HEAD GASKET KIT 1

MF 5709 DYNA 4 TRACTOR (ECO3 / TIER 4F)  
AP9A1604

AP9A1604

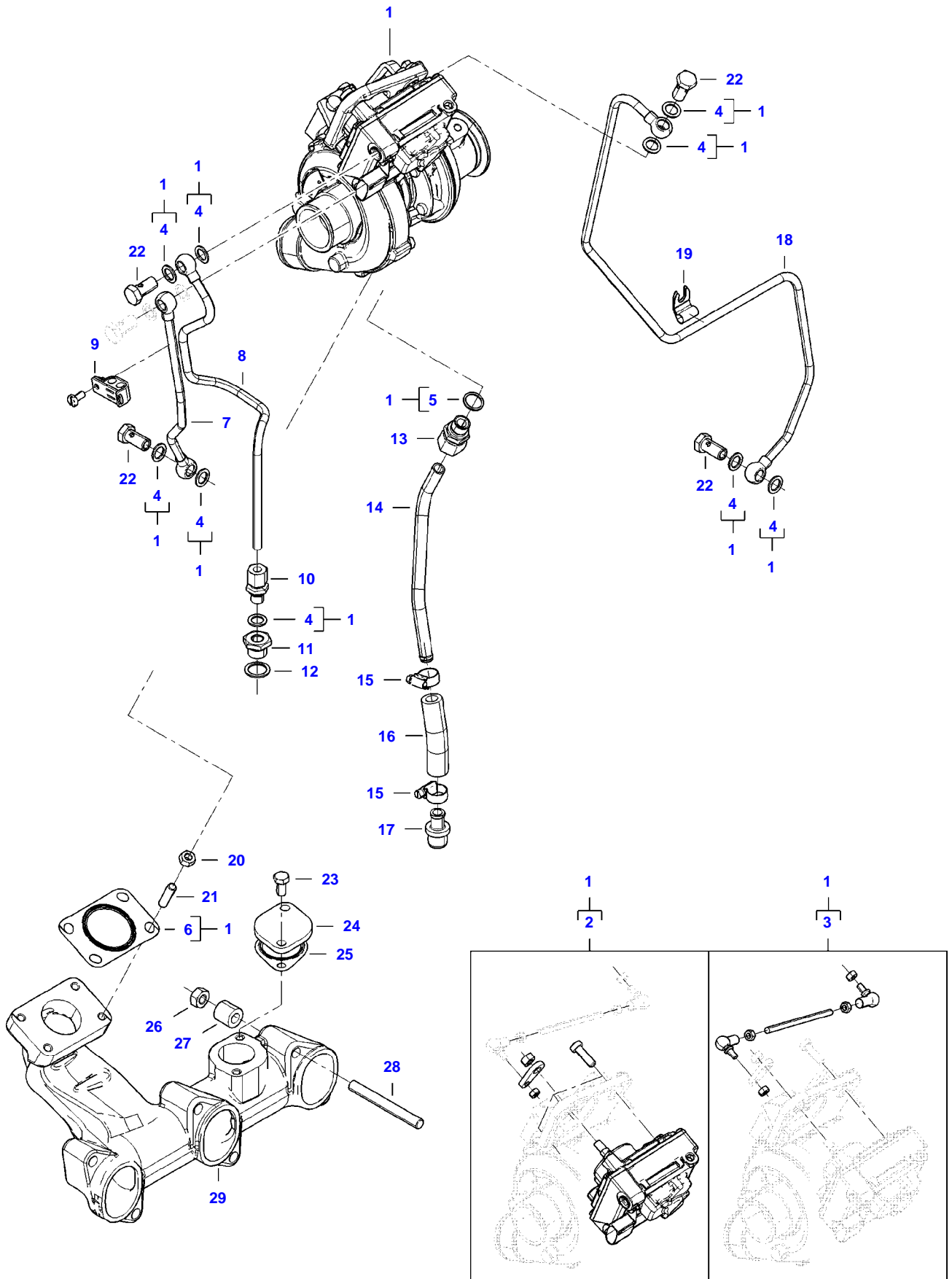

Item	Part Number	Qty	Description Comments
1	V837091183	1	KIT, TURBOCHARGR
2	V837091179	1	KIT, ACTUATOR (1)
3	V837091180	1	ACTUATING ROD (1)
4	V615881218	11	SEALING WASHER (1) [A]
5	V615881620	1	SEALING WASHER (1) [A]
6	V837084804	1	GASKET (1) [A]
7	V837084811	1	WATER PIPE
8	V837084810	1	WATER PIPE
9	V837073721	1	RETAINER CLAMP
10	V641086008	1	STRAIGHT FITTING
11	V835338329	1	UNION
12	V615881824	1	SEALING WASHER [A]
13	V641086012	1	STRAIGHT FITTING
14	V837081991	1	TURBOCHARGER LUBRICATION OIL PIPE
15	V602079516	2	HOSE CLIP
16	V837084856	1	HOSE
17	V837081405	1	FITTING
18	V837081990	1	TURBOCHARGER LUBRICATION OIL PIPE
19	V837081461	1	CLAMP
20	V504800800	4	NUT
21	V546801380	4	STUD BOLT
22	V640435008	5	BANJO BOLT
23	V528801360	2	HEX CAP SCREW
24	V837081055	1	CLOSING PLATE
25	V837081056	1	GASKET [A]
26	V504601000	6	NUT
27	V835346219	6	SPACER PIECE
28	V546801910	6	STUD BOLT
29	V837081994	1	EXHAUST MANIFOLD

[A] INCLUDED IN CYLINDER HEAD GASKET KIT 1

MF 5709 DYNA 4 TRACTOR ( ECO3 / TIER 4F )  
AP13I2601

AP13I2601

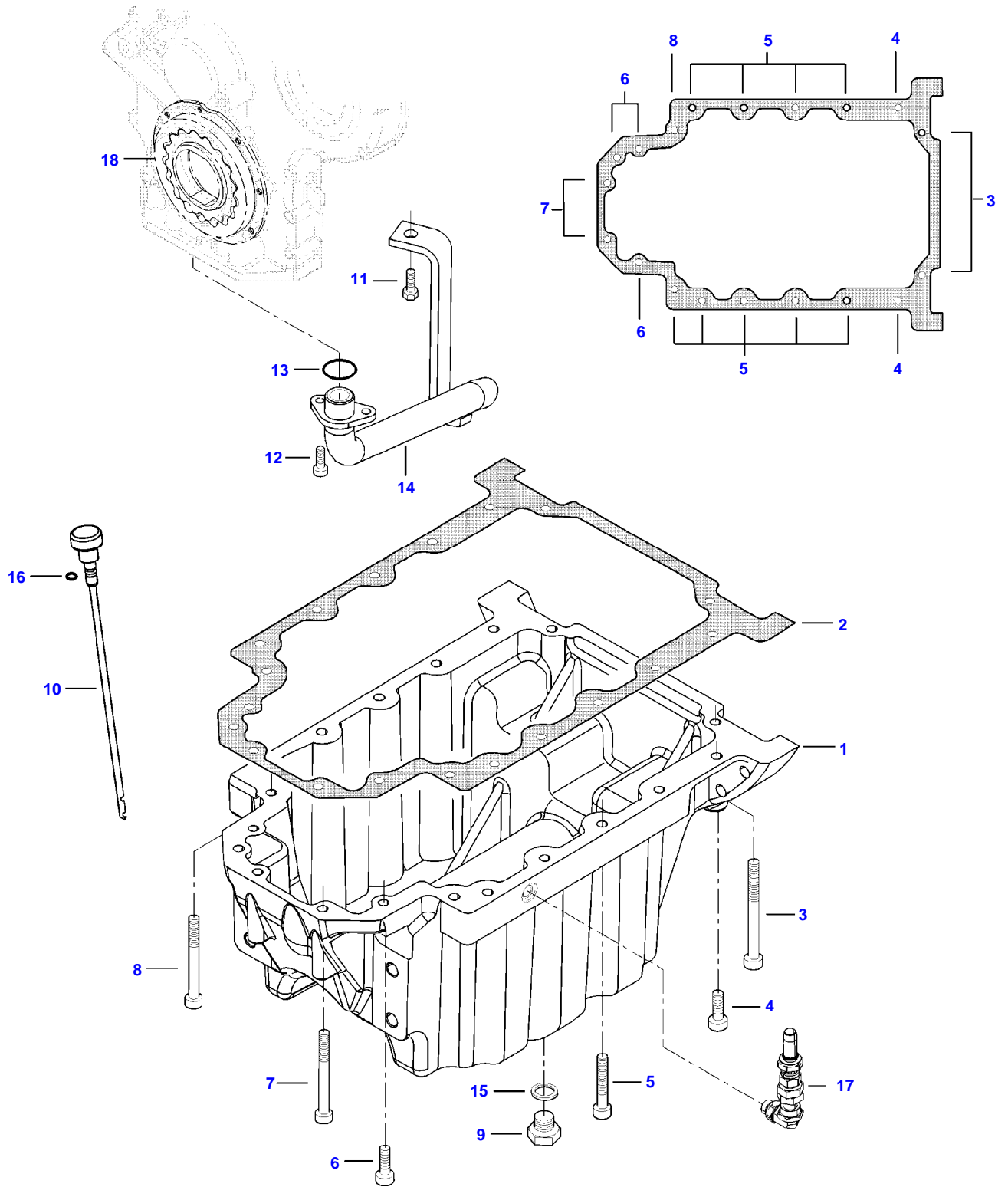

Item	Part Number	Qty	Description Comments
1	V837081021	1	OIL SUMP
2	V837081328	1	OIL SUMP GASKET [B]
3	V581705190	2	HEX SOCKET SCREW
4	V581705030	2	HEX SOCKET SCREW
5	V581705090	9	HEX SOCKET SCREW
6	V581805050	3	HEX SOCKET SCREW
7	V581805170	2	HEX SOCKET SCREW
8	V581705170	1	HEX SOCKET SCREW
9	V836655493	2	PLUG
10	V837081331	1	DIPSTICK
11	V528801360	1	HEX CAP SCREW
12	V581804182	2	HEX SOCKET SCREW
13	V614902124	1	O-RING [B]
14	V837081074	1	OIL PUMP SUCTION PIPE
15	V615881827	2	SEALING WASHER [B]
16	V614900615	1	O-RING
17	V837074234	1	CHECK VALVE
18			

NOT AVAILABLE AS SINGLE PART  
SEE PAGE 01-0003

**[B] INCLUDED IN COMPLETE ENGINE GASKET KIT 2**

MF 5709 DYNA 4 TRACTOR ( ECO3 / TIER 4F )  
AP14I1304

AP14I1304

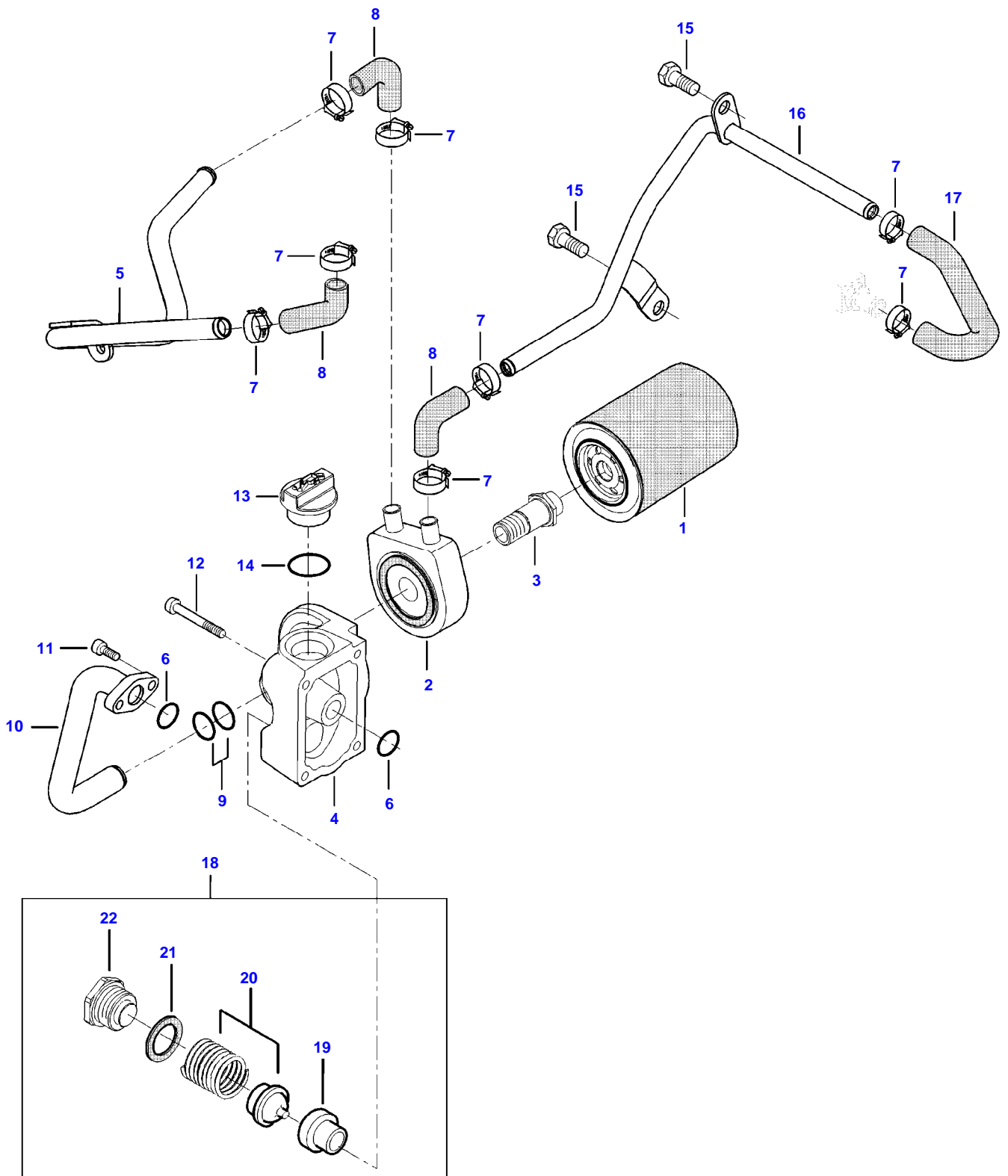



**Suggest:**

**For more complete manuals. Please go to the home page.**

**<https://www.ebooklibonline.com>**

**If the above button click is invalid. Please download this document first, and then click the above link to download the complete manual.**

**Thank you so much for reading**

Item	Part Number	Qty	Description Comments
1	V837079728	1	ENGINE OIL FILTER
2	V837081412	1	OIL FILTER ADAPTER
3	V837081143	1	FITTING
4	V837081053	1	OIL FILTER ADAPTER
5	V837081373	1	WATER PIPE
6	V614602030	2	O-RING [B]
7	V602079516	8	HOSE CLIP
8	V836859899	3	RUBBER ELBOW
9	V614702230	2	O-RING [B]
10	V837081095	1	OIL PIPE
11	V581804602	2	HEX SOCKET SCREW
12	V581804690	4	HEX SOCKET SCREW
13	V837081106	1	OIL FILLER CAP
14	V614603540	1	O-RING [B]
15	V528802180	2	HEX CAP SCREW
16	V837081423	1	WATER PIPE
17	V837081389	1	RUBBER HOSE
18	V837079660	1	OIL PRESSURE CONTROL VALVE
19		1	NOT AVAILABLE AS SINGLE PART (18)
20		1	NOT AVAILABLE AS SINGLE PART (18)
21	V837081174	1	SEALING WASHER (18) [B]
22	V837081175	1	PLUG (18) [B] INCLUDED IN COMPLETE ENGINE GASKET KIT 2

MF 5709 DYNA 4 TRACTOR ( ECO3 / TIER 4F )  
AP1711639

AP1711639

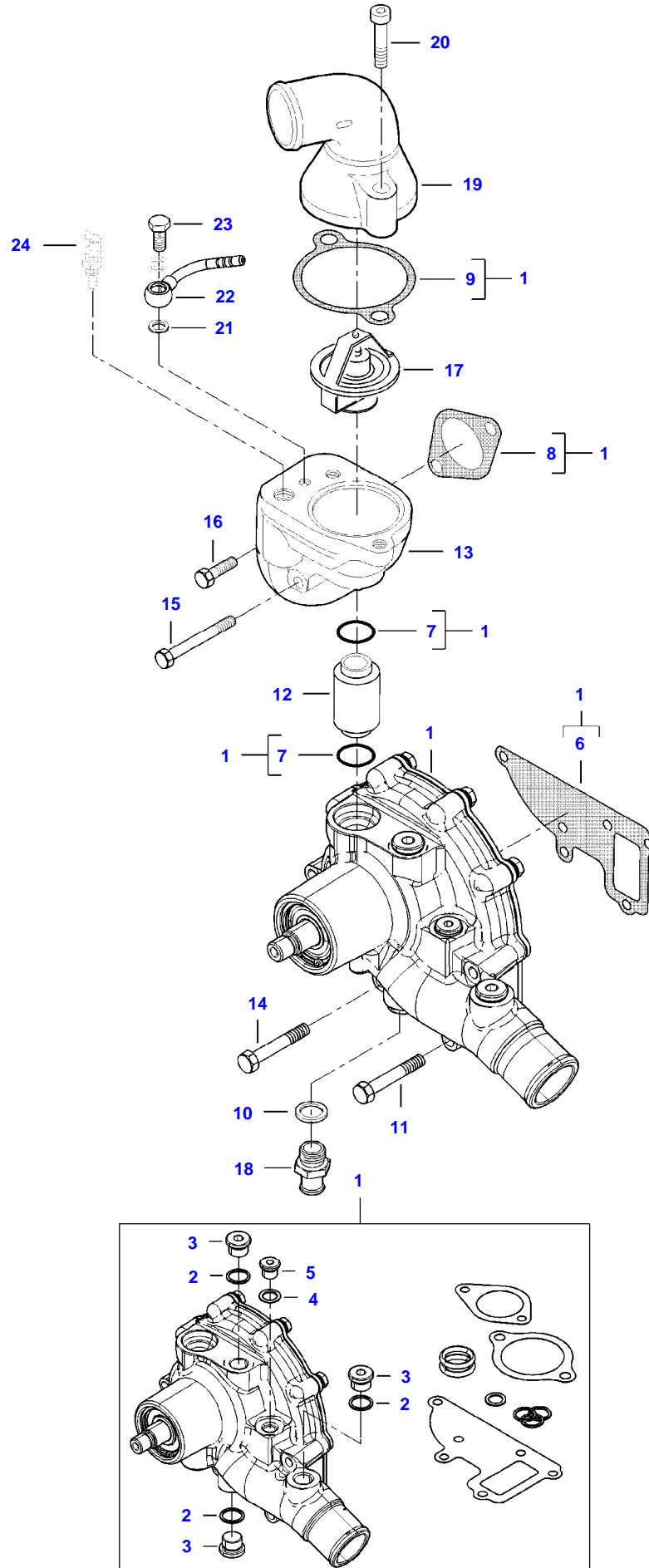

**<https://www.ebooklibonline.com>**

Hello dear friend!

Thank you very much for reading.

Enter the link into your browser.

The full manual is available for immediate download.

**<https://www.ebooklibonline.com>**