

<b>Page Number</b>	<b>Page Title</b>	<b>Page Reference</b>
01-000-TOC	ENGINE V832677604 44 DTIC2	01-000-TOC
02-000-TOC	ENGINE V832677652 44 TIC	02-000-TOC
03-000-TOC	ENGINE ACW1606200 44 DTIC2	03-000-TOC
04-000-TOC	ENGINE ACW1606270 44 CWC3	04-000-TOC
05-000-TOC	ENGINE INSTALLATION	05-000-TOC
06-000-TOC	AXLES	06-000-TOC
07-000-TOC	STEERING SYSTEM	07-000-TOC
08-000-TOC	DRIVE TRAIN SYSTEM	08-000-TOC
09-000-TOC	BRAKE SYSTEM	09-000-TOC
10-000-TOC	HYDRAULIC SYSTEM	10-000-TOC
11-000-TOC	ELECTRICAL SYSTEM	11-000-TOC
12-000-TOC	CAB	12-000-TOC
13-000-TOC	CHASSIS	13-000-TOC
14-000-TOC	DECALS	14-000-TOC
15-000-TOC	WHEELS	15-000-TOC
16-000-TOC	IMPLEMENT DRIVE SYSTEM	16-000-TOC
17-000-TOC	IMPLEMENT LIFT SYSTEM REAR	17-000-TOC
18-000-TOC	LINKAGE	18-000-TOC
19-000-TOC	ACCESSORIES	19-000-TOC
20-000-TOC	GENERAL INFORMATION	20-000-TOC

<b>Page Number</b>	<b>Page Title</b>	<b>Page Reference</b>
01-0001	ENGINE ASSEMBLIES	1MDL1725714
01-0002	CYLINDER BLOCK	1MDL1725671
01-0003	TIMING GEAR COVER	1MDL1725672
01-0004	CRANKSHAFT AND PISTONS	1MDL1725673
01-0005	CAMSHAFT AND VALVE MECHANISM	1MDL1725674
01-0006	CYLINDER HEAD	1MDL1725675
01-0007	INTAKE MANIFOLD	1MDL1725676
01-0008	TURBOCHARGER AND EXHAUST MANIFOLD	1MDL1725678
01-0009	OIL SUMP	1MDL1725679
01-0010	OIL COOLER AND FILTER	1MDL1725680
01-0011	COOLANT PUMP AND THERMOSTAT	1MDL1725681
01-0012	FUEL INJECTION SYSTEM - UP TO ENGINE SERIAL NUMBER FCEXXXXXX	1MDL1725736
01-0013	FUEL FILTERS	1MDL1725682
01-0014	ENGINE OVERHAUL PARTS	1MDL1725683



**<https://www.ebooklibonline.com>**

Hello dear friend!

Thank you very much for reading.

Enter the link into your browser.

The full manual is available for immediate download.

**<https://www.ebooklibonline.com>**

<b>Item</b>	<b>Part Number</b>	<b>Qty</b>	<b>Description Comments</b>	<b>Technical Specification</b>
1	V832677604	1	ENGINE 91/2200 (KW/RPM)	44 DTIC2
2	V837081451	1	SHORT BLOCK ENGINE	44 TC/TIC
3	V837079921	1	LABEL	

MF 6712R TRACTOR ( ECO4 / TIER 2 -3 ; BR )  
AP1J1354

AP1J1354

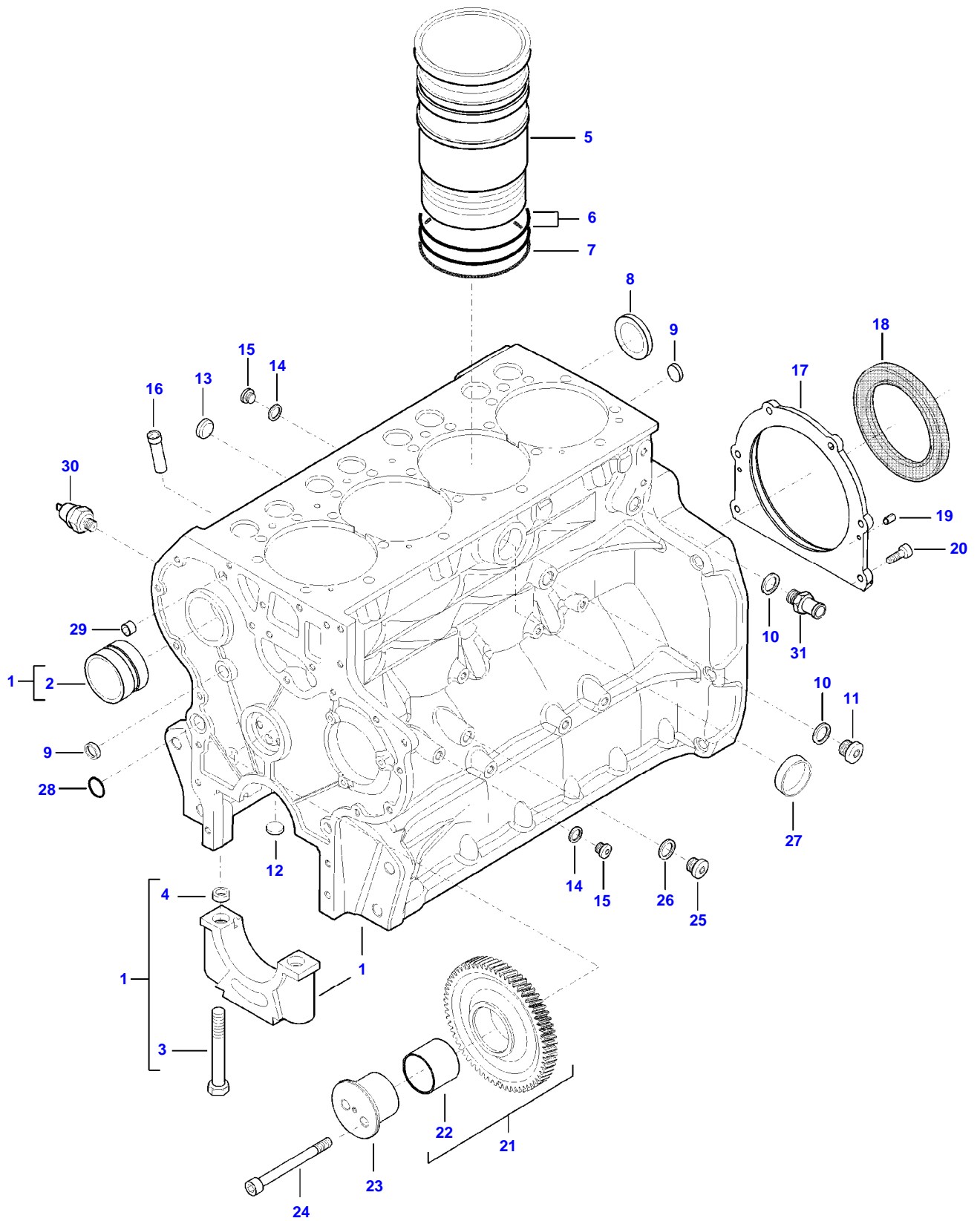

Item	Part Number	Qty	Description Comments
1	V837081301	1	CYLINDER BLOCK
2	V836866069	1	CAMSHAFT BEARING BUSH [A]
3	V837081037	10	HEX CAP SCREW [A]
4	V837081041	10	GUIDE SLEEVE [A]
5	V837081031	4	LINER
6	V836647502	8	CYLINDER LINER O-RING INCLUDED IN GASKET KIT 2
7	V836647503	4	CYLINDER LINER O-RING INCLUDED IN GASKET KIT 2
8	V837081133	1	PLUG
9	V640016016	2	PLUG
10	V615881824	2	SEALING WASHER INCLUDED IN GASKET KIT 2
11	V640325018	1	PLUG
12	V640016020	1	PLUG
13	V640016018	2	PLUG
14	V615871014	2	SEALING WASHER INCLUDED IN GASKET KIT 2
15	V640325110	2	PLUG
16	V837081103	1	PIPE
17	V837081321	1	COVER
18	V837081286	1	CRANKSHAFT SEAL INCLUDED IN GASKET KIT 2
19	V595959140	2	PIN
20	V581804580	6	HEX SOCKET SCREW
21	V837081084	1	IDLER GEAR
22	V837081019	1	BUSH [B]
23	V837081017	1	SHAFT
24	V581705100	2	HEX SOCKET SCREW
25	V640325014	1	PLUG
26	V615881420	1	SEALING WASHER INCLUDED IN GASKET KIT 2
27	V640016040	1	PLUG
28	V614602030	1	O-RING INCLUDED IN GASKET KIT 2
29	V598359850	2	PIN
30	V887283760	1	PRESSURE SWITCH
31	V837081395	1	HOSE COUPLER [A] INCLUDED IN ITEM 1 [B] INCLUDED IN ITEM 21

MF 6712R TRACTOR ( ECO4 / TIER 2 -3 ; BR )  
AP2J1357

AP2J1357

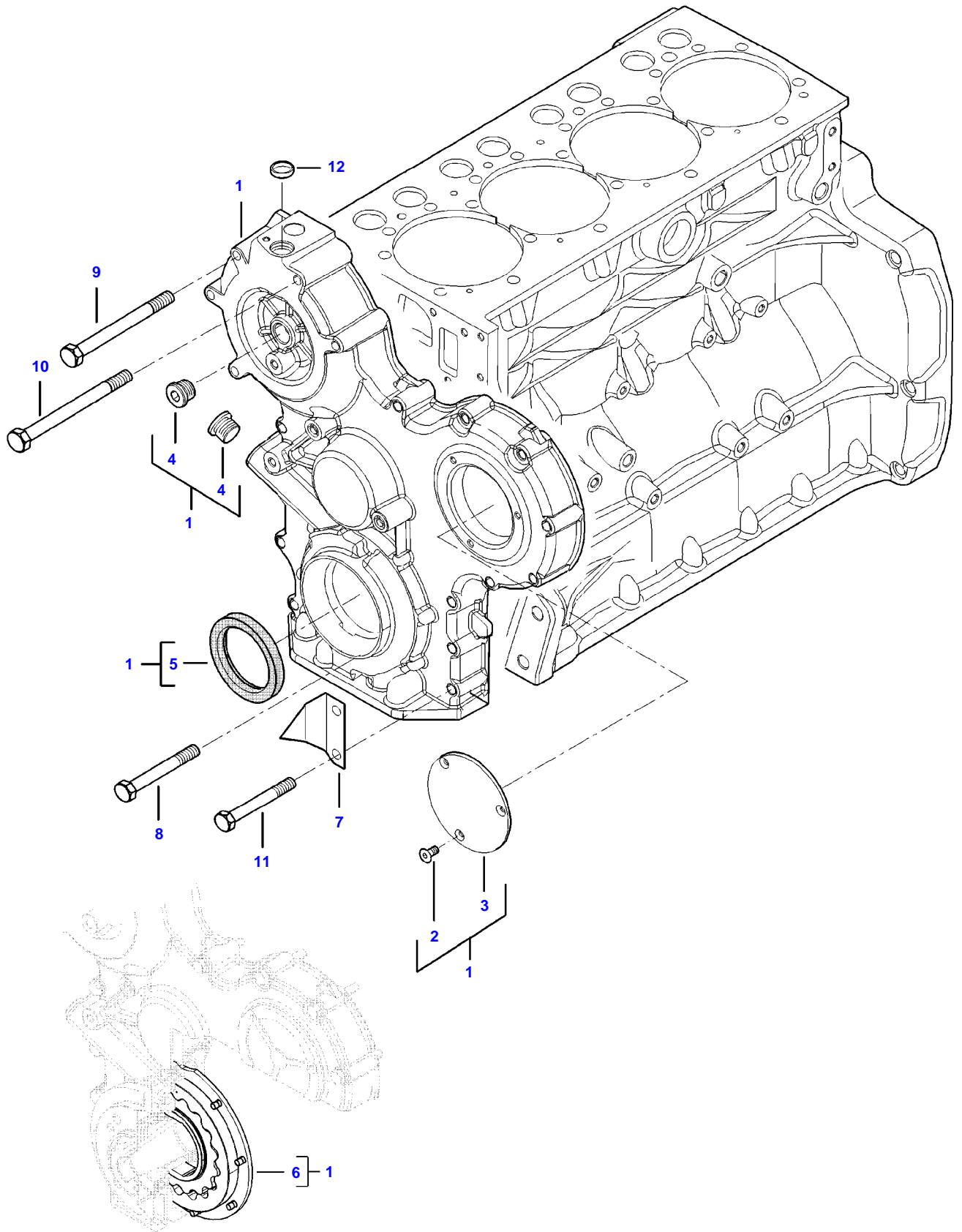

Item	Part Number	Qty	Description Comments
1	V837081039	1	TIMING GEAR CASE
2	V579904162	3	HEX SOCKET SCREW [A]
3	V837081057	1	COVER [A]
4	V640325120	2	PLUG [A]
5	V836840883	1	CRANKSHAFT SEAL INCLUDED IN GASKET KIT 2 [A]
6			NOT AVAILABLE AS SINGLE PART [A]
7	V837081022	1	TIMING MARK INDICATOR
8	V540801470	1	HEXAGON FLANGE BOLT
9	V540801490	4	HEXAGON FLANGE BOLT
10	V540801510	1	HEXAGON FLANGE BOLT
11	V540801450	12	HEXAGON FLANGE BOLT
12	V640016018	1	PLUG [A] INCLUDED IN ITEM 1

MF 6712R TRACTOR ( ECO4 / TIER 2 -3 ; BR )  
AP4J1359

AP4J1359

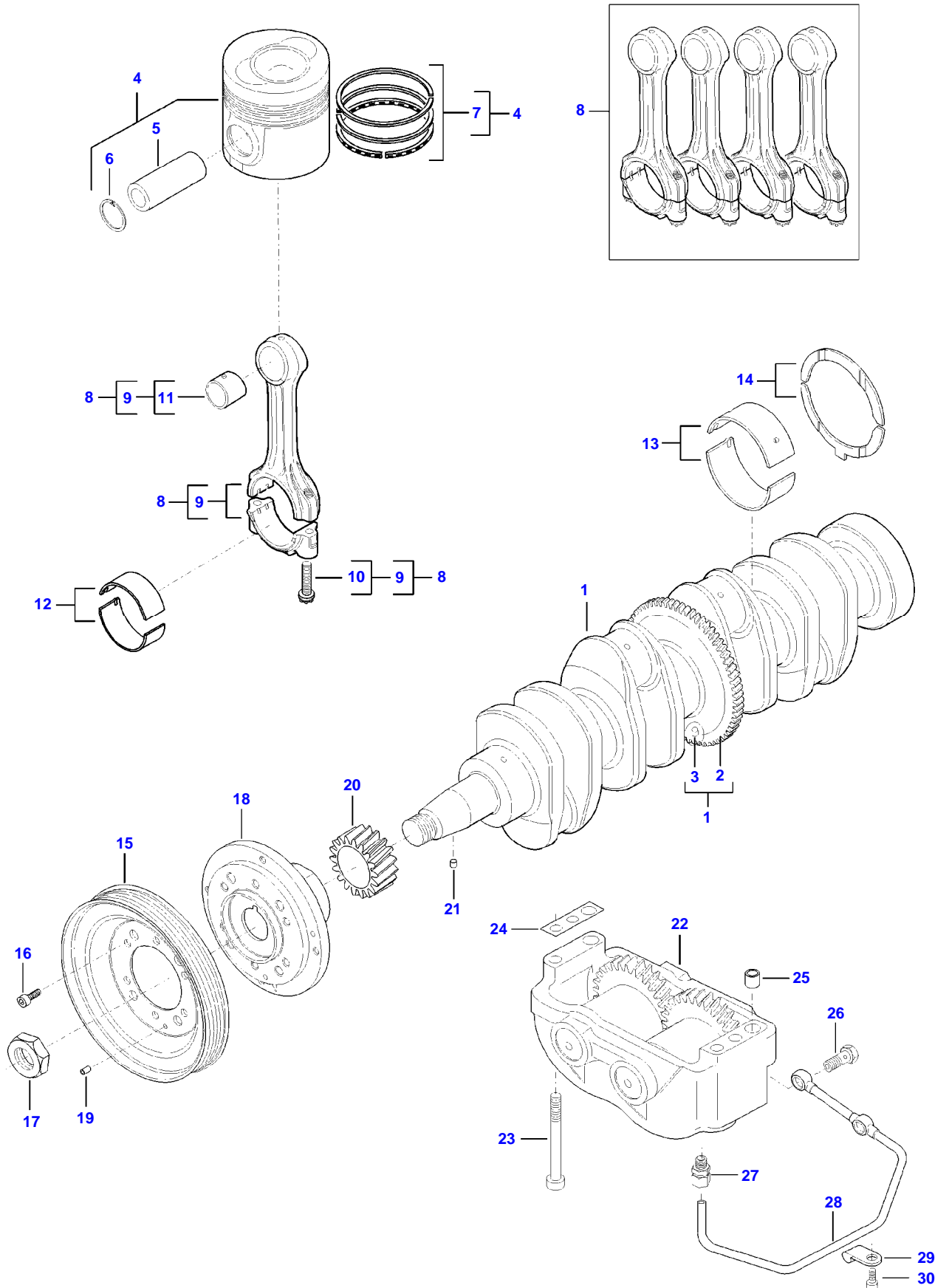

Item	Part Number	Qty	Description Comments
1	V837081276	1	CRANKSHAFT
2	V837081275	1	GEAR
3	V837081240	1	KEY
4	V837081457	4	PISTON
5		4	NOT AVAILABLE AS SINGLE PART [A]
6		8	NOT AVAILABLE AS SINGLE PART [A]
7	V837079658	4	PISTON RING SET [A]
8	V837079729	1	KIT, CONROD
9		4	NOT AVAILABLE AS SINGLE PART [B]
10	V837081024	8	CONNECTING ROD BOLT [B][C]
11	V837081025	4	BUSH [B][C]
12	V837091164	4	CONROD BEARING
13	V836655514	5	MAIN BEARING
14	V836119459	2	THRUST WASHER
15	V837081325	1	CRANKSHAFT PULLEY
16	V581804602	6	HEX SOCKET SCREW
17	V837081149	1	NUT
18	V837081051	1	CRANKSHAFT HUB
19	V595953360	1	PIN
20	V837081012	1	GEAR,CRANKSHAFT
21	V837081240	2	KEY
22	V837081228	1	BALANCER
23	V581805170	4	HEX SOCKET SCREW
24	V836119920		SHIM AS REQUIRED, REFER TO WORKSHOP MANUAL
25	V598359850	2	PIN
26	V640435008	2	BANJO BOLT
27	V641016008	1	STRAIGHT FITTING
28	V837081295	1	OIL PIPE
29	V602071608	1	HOSE CLIP
30	V581804182	1	HEX SOCKET SCREW

**[A] INCLUDED IN ITEM 4**

**[B] INCLUDED IN ITEM 8**

**[C] INCLUDED IN ITEM 9**

MF 6712R TRACTOR ( ECO4 / TIER 2 -3 ; BR )  
AP5J1361

AP5J1361

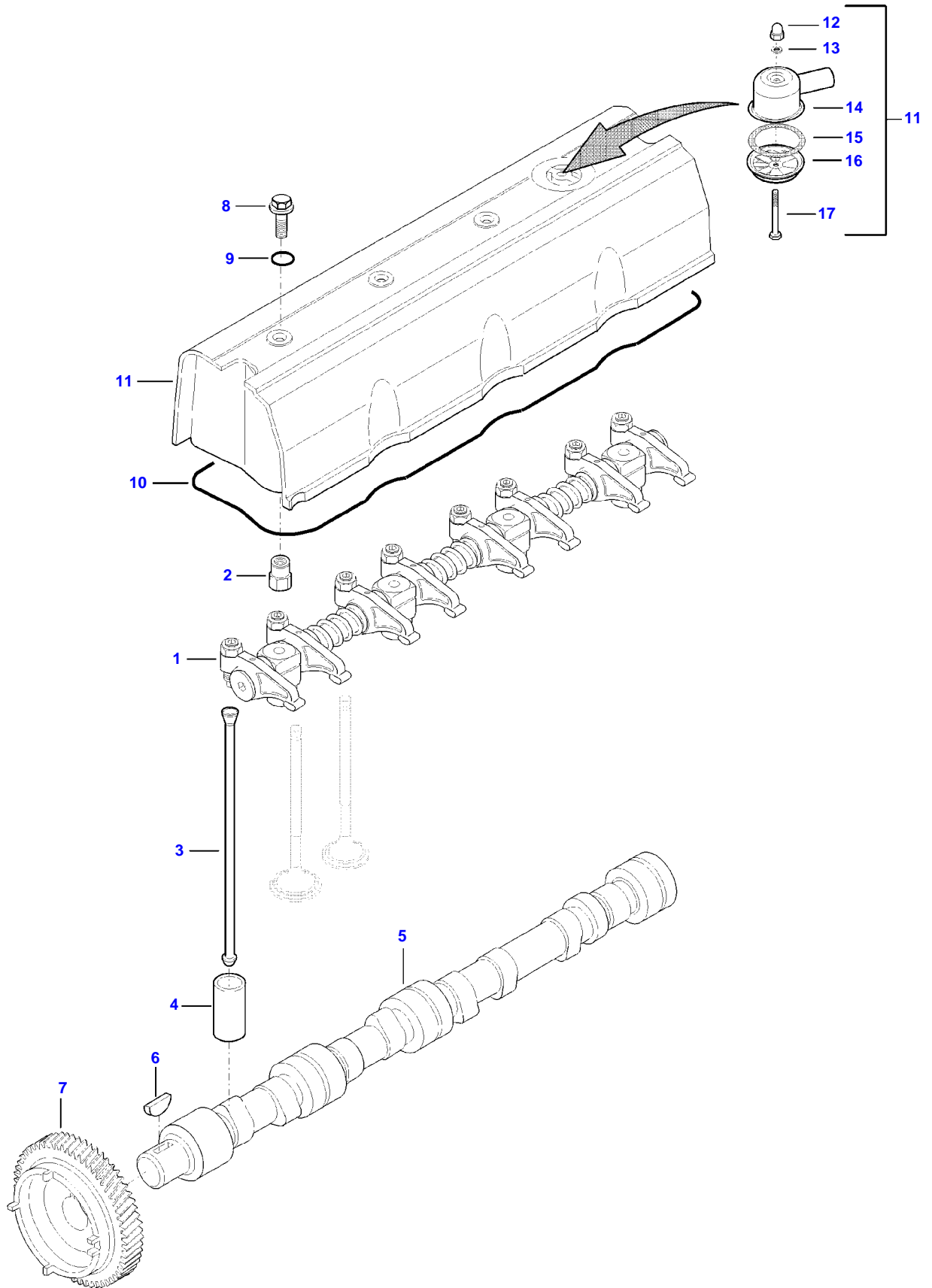

Item	Part Number	Qty	Description Comments
1	V836767044	1	ROCKER SHAFT ASM
2	V836655406	4	NUT
3	V837081220	8	PUSH ROD
4	V836014264	8	TAPPET
5	V837081127	1	CAMSHAFT
6	V603305760	1	WOODRUFF KEY
7	V837081014	1	GEAR,CAMSHAFT
8	V540801780	4	HEXAGON FLANGE BOLT
9	V614901030	4	O-RING
10	V836767244	1	INCLUDED IN GASKET KIT 1 VALVE ROCKER COVER GASKET INCLUDED IN GASKET KIT 1
11	V837070461	1	VALVE ROCKER COVER
12	V519600602	1	NUT [A]
13	V836667508	1	SEALING WASHER [A]
14	V837070442	1	BREATHER [A]
15	V836667459	1	GASKET [A]
16	V837070443	1	BREATHER [A]
17	V528801172	1	HEX CAP SCREW [A] [A] INCLUDED IN ITEM 11

MF 6712R TRACTOR ( ECO4 / TIER 2 -3 ; BR )  
AP6J1363

AP6J1363

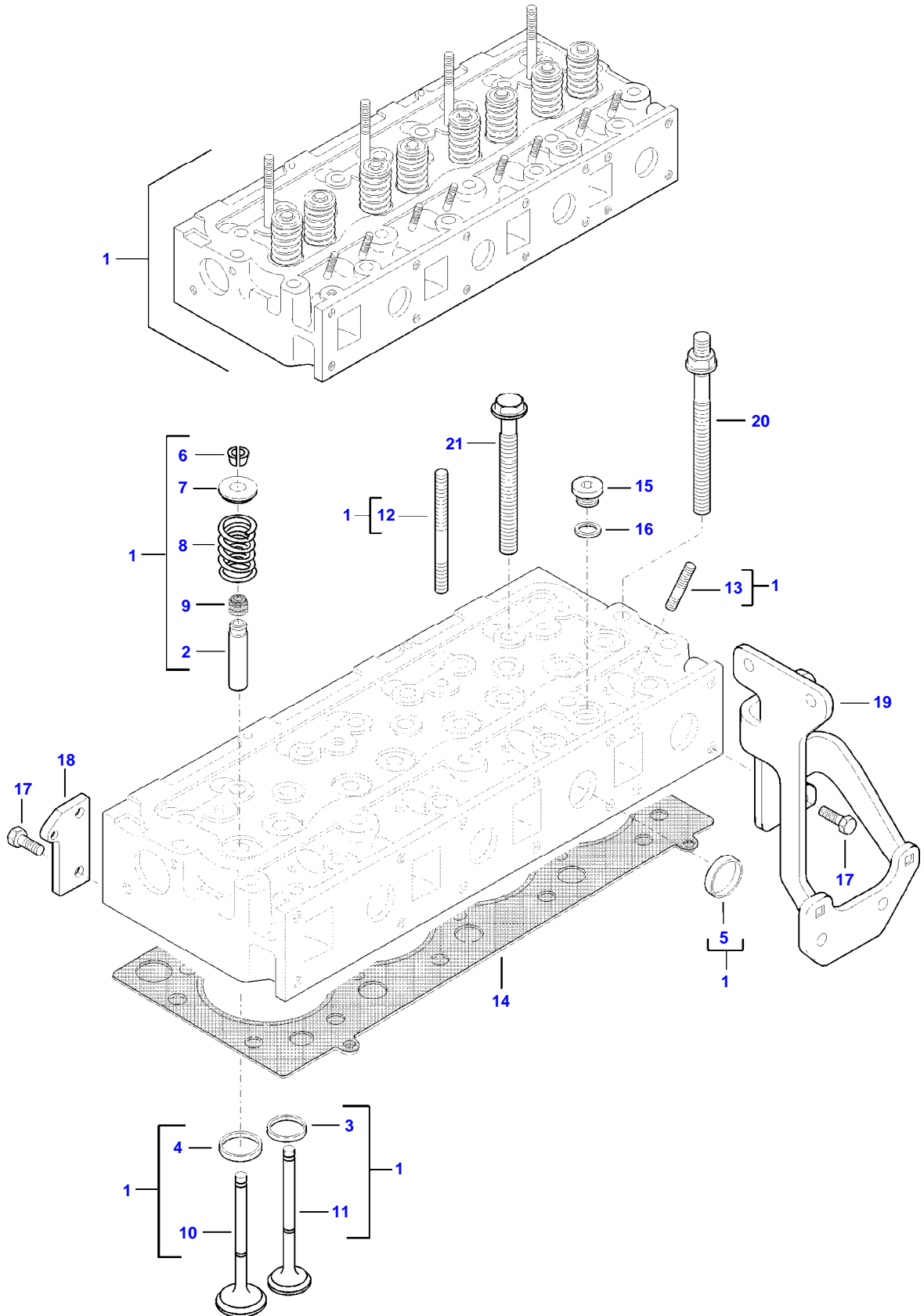

Item	Part Number	Qty	Description Comments
1	V837081496	1	CYLINDER HEAD
2	V836673175	8	VALVE GUIDE [A]
3	V836647600	4	VALVE SEAT [A]
4	V836647936	4	VALVE SEAT [A]
5	V836647942	8	PLUG [A]
6	V836646382	16	COTTER [A]
7	V836646381	8	WASHER [A]
8	V837073405	8	VALVE SPRING [A]
9	V837073166	8	VALVE STEM GASKET INCLUDED IN GASKET KIT 1 [A]
10	V836646356	4	INTAKE VALVE [A]
11	V836646357	4	EXHAUST VALVE [A]
12	V546801900	4	STUD BOLT [A]
13	V546901435	8	STUD BOLT [A]
14	V837084524	1	CYLINDER HEAD GASKET INCLUDED IN GASKET KIT 1
15	V640325018	1	PLUG
16	V615881824	1	SEALING WASHER INCLUDED IN GASKET KIT 1
17	V528801800	4	HEX CAP SCREW
18	V837081397	1	COVER
19	V837081424	1	FUEL FILTER BRACKET
20	V837073571	5	CYLINDER HEAD BOLT
21	V837069025	17	CYLINDER HEAD BOLT [A] INCLUDED IN ITEM 1

MF 6712R TRACTOR ( ECO4 / TIER 2 -3 ; BR )  
AP7J1364

AP7J1364

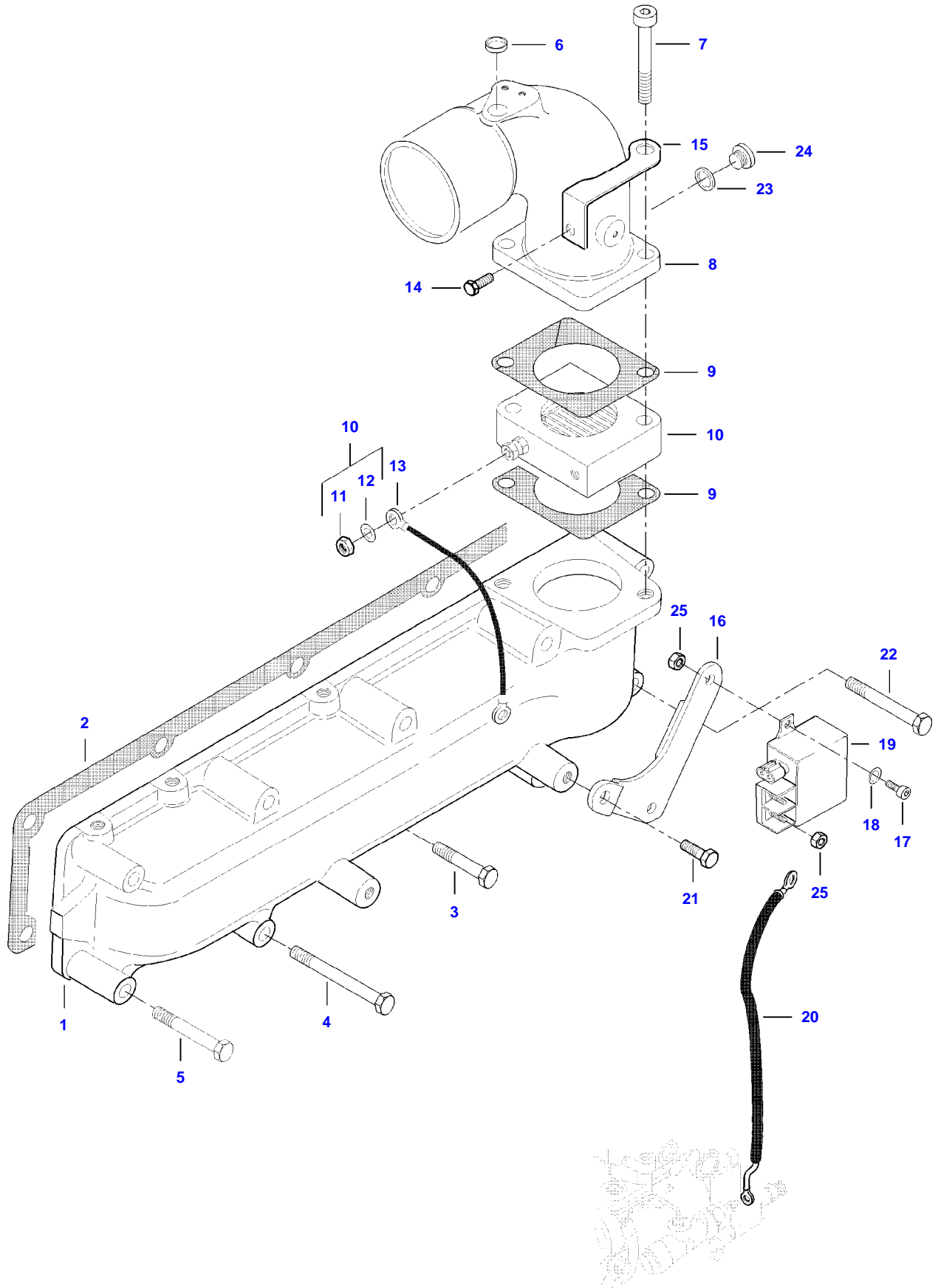

Item	Part Number	Qty	Description Comments
1	V837070298	1	INTAKE MANIFOLD
2	V836747595	1	INTAKE MANIFOLD GASKET INCLUDED IN GASKET KIT 1
3	V529801450	1	HEX CAP SCREW
4	V529801510	2	HEX CAP SCREW
5	V529801470	6	HEX CAP SCREW
6	V640016012	1	PLUG
7	V581705070	2	HEX SOCKET SCREW
8	V837081490	1	AIR PIPE
9	V836666074	2	GASKET INCLUDED IN GASKET KIT 1
10	V837081194	1	INTAKE AIR PREHEATER
11	V504600602	1	NUT [A]
12	V500050642	1	WASHER [A]
13	V837081491	1	WIRE
14	V528801052	1	HEX CAP SCREW
15	V837081193	1	PLATE
16	V837081218	1	BRACKET
17	V581804182	2	HEX SOCKET SCREW
18	V500050642	2	WASHER
19	V837069047	1	SOLENOID
20	V836673373	1	WIRE
21	V528801362	1	HEX CAP SCREW
22	V529801480	1	HEX CAP SCREW
23	V615881420	1	SEALING WASHER
24	V640325014	1	PLUG
25	V504600602	3	NUT [A] INCLUDED IN ITEM 10

MF 6712R TRACTOR ( ECO4 / TIER 2 -3 ; BR )  
AP9J1367

AP9J1367

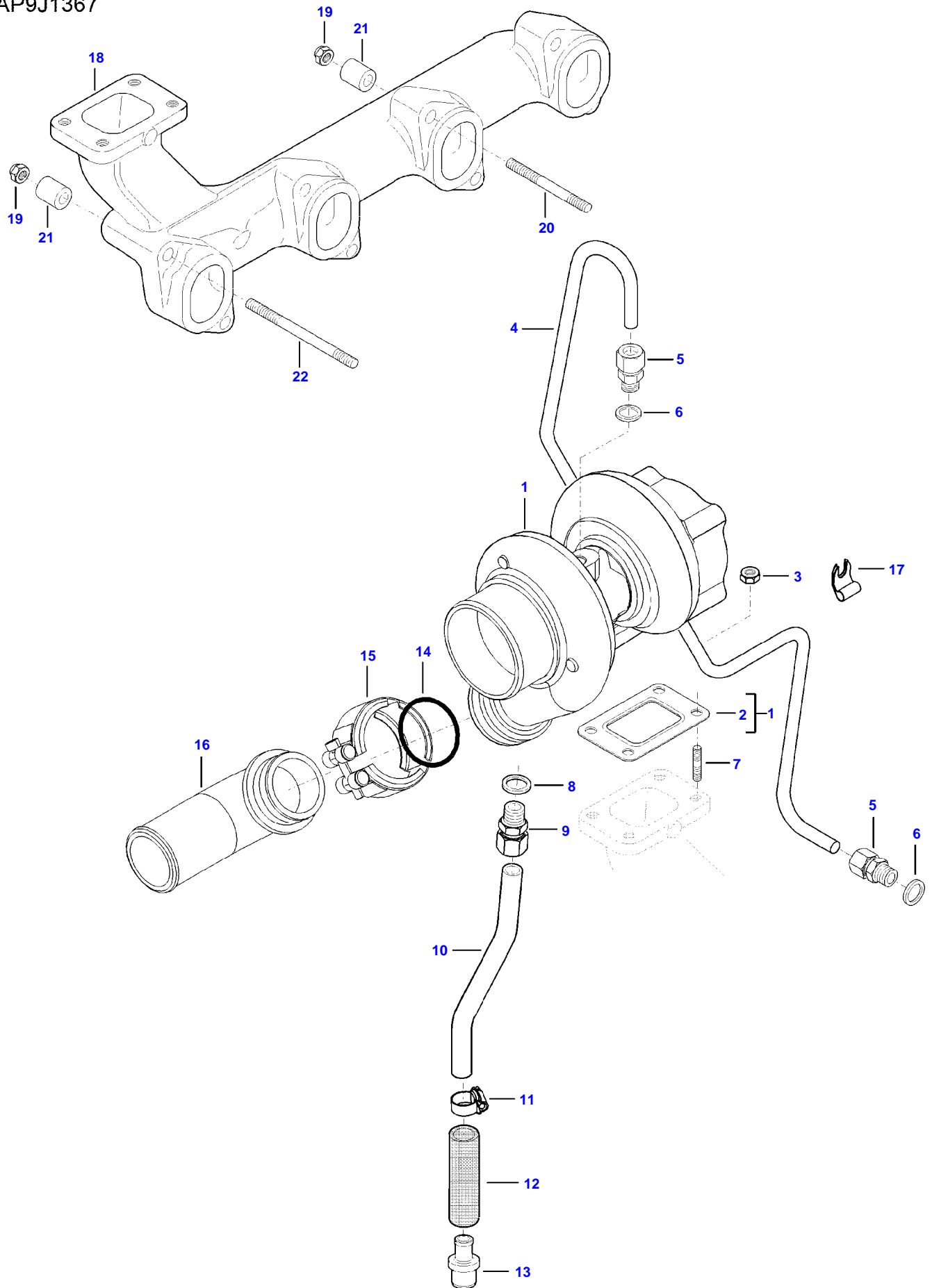

Item	Part Number	Qty	Description Comments
1	V836767448	1	TURBOCHARGER
2	V836784847	1	GASKET INCLUDED IN GASKET KIT 1 [A]
3	V504800800	4	NUT
4	V837081464	1	TURBOCHARGER LUBRICATION OIL PIPE
5	V641086008	2	STRAIGHT FITTING
6	V615881216	2	SEALING WASHER INCLUDED IN GASKET KIT 1
7	V546801380	4	STUD BOLT
8	V615881620	1	SEALING WASHER INCLUDED IN GASKET KIT 1
9	V641086012	1	STRAIGHT FITTING
10	V837081465	1	TURBOCHARGER LUBRICATION OIL PIPE
11	V602079516	2	HOSE CLIP
12	V837084856	1	HOSE
13	V837081405	1	FITTING
14	V614604530	1	O-RING
15	V836766717	1	V CLAMP
16	V836766707	1	AIR PIPE
17	V837081461	1	CLAMP
18	V837081426	1	EXHAUST MANIFOLD
19	V513601002	8	NUT
20	V546801910	7	STUD BOLT
21	V835346219	8	SPACER PIECE
22	V546801960	1	STUD BOLT [A] INCLUDED IN ITEM 1

MF 6712R TRACTOR ( ECO4 / TIER 2 -3 ; BR )  
AP13J1369

AP13J1369

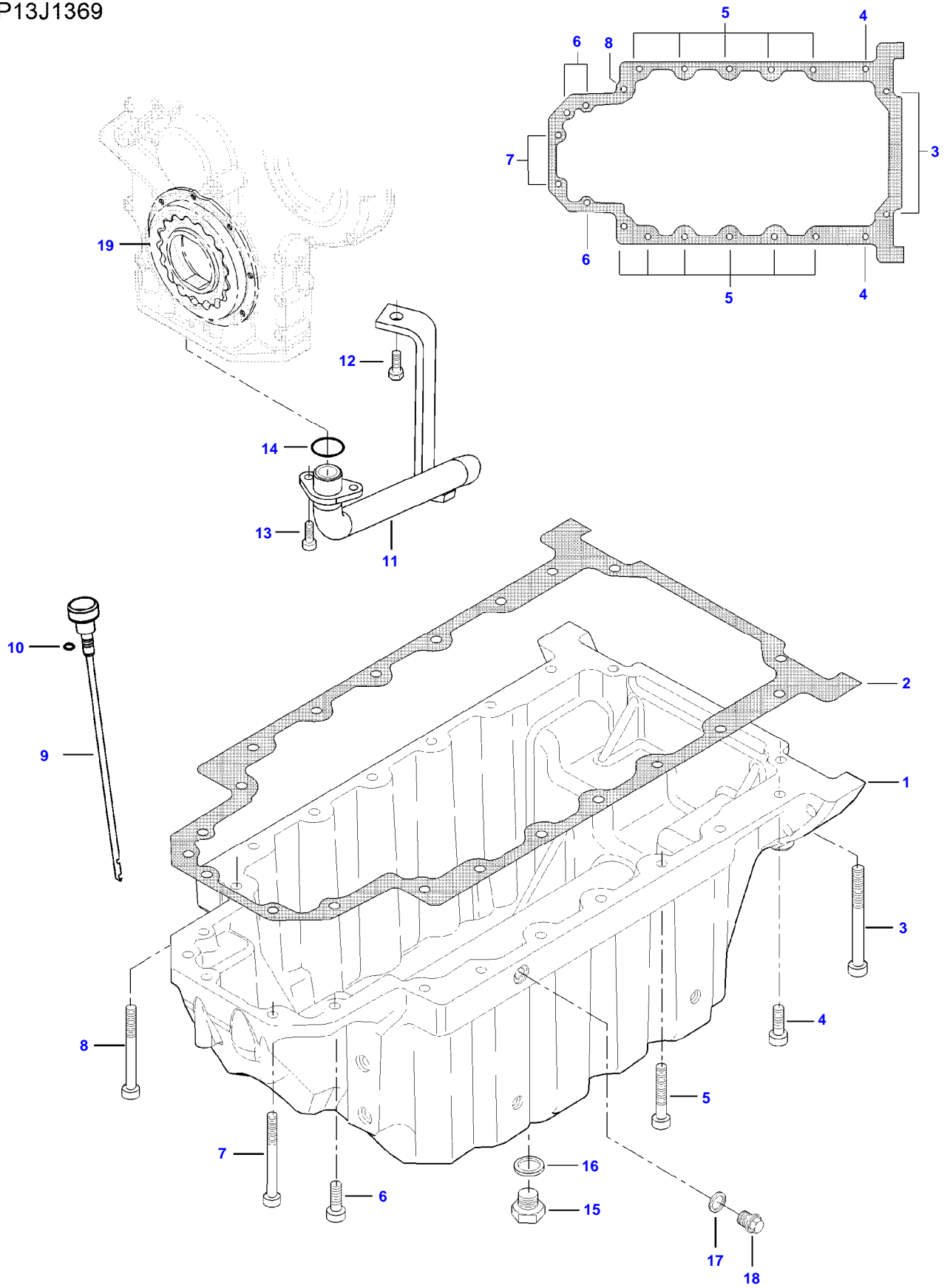

Item	Part Number	Qty	Description Comments
1	V837081085	1	OIL SUMP
2	V837081161	1	OIL SUMP GASKET INCLUDED IN GASKET KIT 2
3	V581705190	2	HEX SOCKET SCREW
4	V581705030	2	HEX SOCKET SCREW
5	V581705090	11	HEX SOCKET SCREW
6	V581805040	3	HEX SOCKET SCREW
7	V581805170	2	HEX SOCKET SCREW
8	V581705170	1	HEX SOCKET SCREW
9	V837081331	1	DIPSTICK
10	V614900615	1	O-RING
11	V837081074	1	OIL PUMP SUCTION PIPE
12	V528801360	1	HEX CAP SCREW
13	V581804182	2	HEX SOCKET SCREW
14	V614902124	1	O-RING INCLUDED IN GASKET KIT 2
15	V836655493	2	PLUG
16	V615881827	2	SEALING WASHER INCLUDED IN GASKET KIT 2
17	V615881420	1	SEALING WASHER INCLUDED IN GASKET KIT 2
18	V640305014	1	PLUG
19			NOT AVAILABLE AS SINGLE PART SEE PAGE 01-0003

MF 6712R TRACTOR ( ECO4 / TIER 2 -3 ; BR )  
AP14I1304

AP14I1304

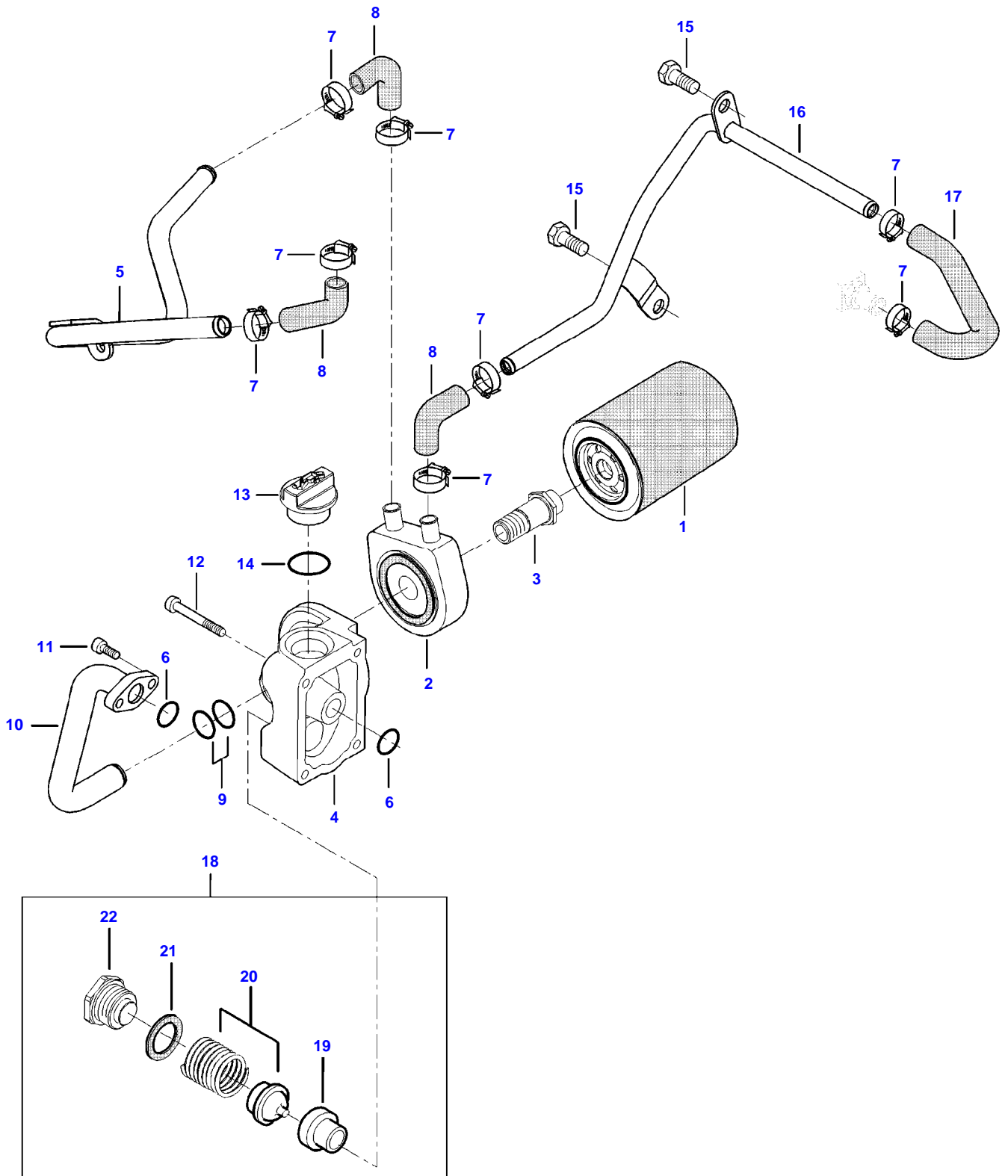

Item	Part Number	Qty	Description Comments
1	V837079728	1	ENGINE OIL FILTER
2	V837081412	1	OIL FILTER ADAPTER
3	V837081143	1	FITTING
4	V837081053	1	OIL FILTER ADAPTER
5	V837081373	1	WATER PIPE
6	V614602030	2	O-RING INCLUDED IN GASKET KIT 2
7	V602079516	8	HOSE CLIP
8	V836859899	3	RUBBER ELBOW
9	V614702230	2	O-RING INCLUDED IN GASKET KIT 2
10	V837081095	1	OIL PIPE
11	V581804620	2	HEX SOCKET SCREW
12	V581804690	4	HEX SOCKET SCREW
13	V837081106	1	OIL FILLER CAP
14	V614603540	1	O-RING INCLUDED IN GASKET KIT 2
15	V528802180	2	HEX CAP SCREW
16	V837081372	1	WATER PIPE
17	V837081389	1	RUBBER HOSE
18	V837079660	1	OIL PRESSURE CONTROL VALVE
19	V836659521	1	VALVE SEAT [A]
20	V836667649	1	SPRING ASSEMBLY [A]
21	V837081174	1	SEALING WASHER INCLUDED IN GASKET KIT 2 [A]
22	V837081175	1	PLUG [A] <b>[A] INCLUDED IN ITEM 18</b>

MF 6712R TRACTOR ( ECO4 / TIER 2 -3 ; BR )  
AP1711305

AP1711305

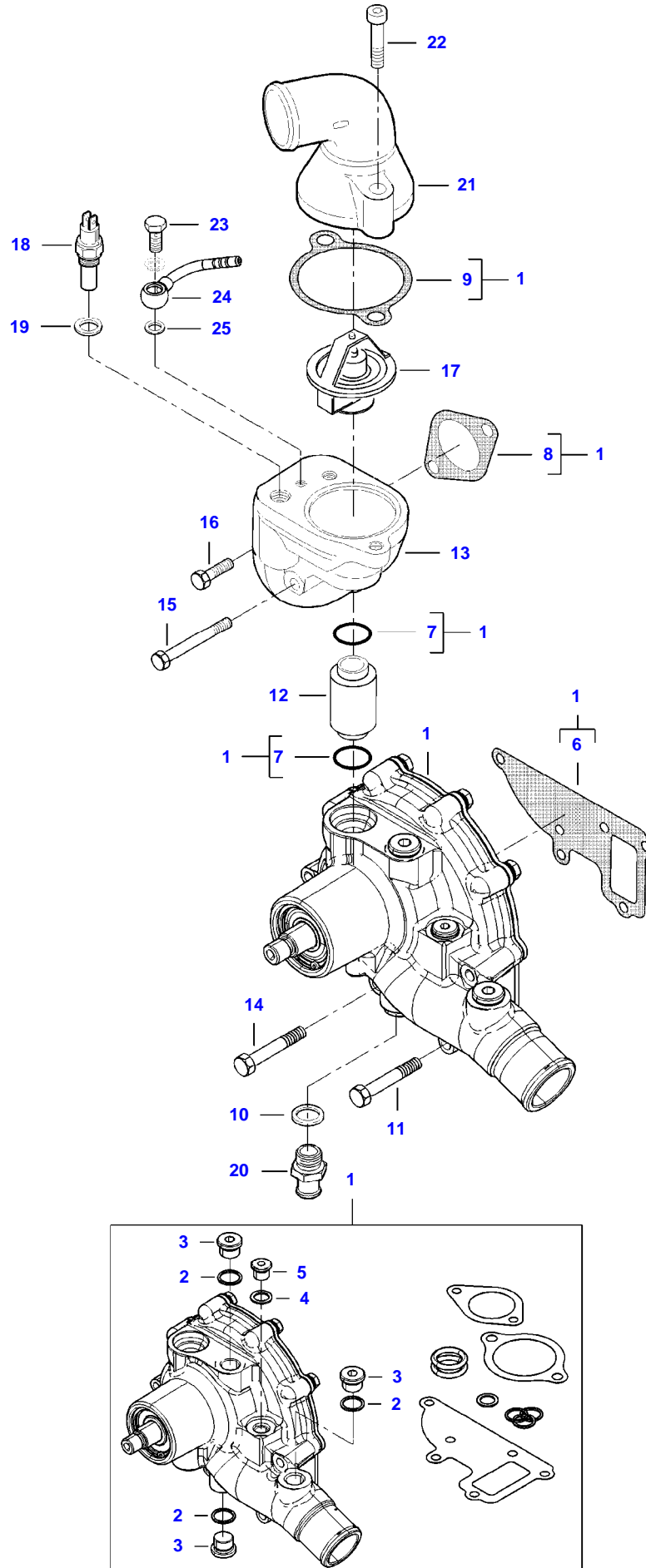



**Suggest:**

**For more complete manuals. Please go to the home page.**

**<https://www.ebooklibonline.com>**

**If the above button click is invalid. Please download this document first, and then click the above link to download the complete manual.**

**Thank you so much for reading**

Item	Part Number	Qty	Description Comments
1	V837091844	1	KIT,WATER PUMP
2	V615881822	3	SEALING WASHER INCLUDED IN GASKET KIT 2 [A]
3	V640325018	3	PLUG [A]
4	V615881420	1	SEALING WASHER INCLUDED IN GASKET KIT 2 [A]
5	V640325014	1	PLUG [A]
6	V837081124	1	GASKET INCLUDED IN GASKET KIT 2 [A]
7	V614602550	2	O-RING INCLUDED IN GASKET KIT 1 [A]
8	V837081126	1	GASKET INCLUDED IN GASKET KIT 1 [A]
9	V837081125	1	GASKET INCLUDED IN GASKET KIT 1 [A]
10	V615881822	1	SEALING WASHER
11	V529801480	3	HEX CAP SCREW
12	V837081120	1	WATER PIPE
13	V837081473	1	THERM. HOUSING
14	V529801470	1	HEX CAP SCREW
15	V529801540	1	HEX CAP SCREW
16	V528801402	1	HEX CAP SCREW
17	V837081319	1	THERMOSTAT
18	V836640772	1	TEMPERATURE SENSOR.
19	V615881418	1	SEALING WASHER INCLUDED IN GASKET KIT 1
20	V837081395	1	HOSE COUPLER
21	V837081362	1	COVER
22	V581705070	2	HEX SOCKET SCREW
23	V640435006	1	BANJO BOLT
24	V837081034	1	WATER PIPE
25	V615871014	2	SEALING WASHER INCLUDED IN GASKET KIT 1 <b>[A] INCLUDED IN ITEM 1</b>



**<https://www.ebooklibonline.com>**

Hello dear friend!

Thank you very much for reading.

Enter the link into your browser.

The full manual is available for immediate download.

**<https://www.ebooklibonline.com>**