

**JOHN DEERE**  
**WORLDWIDE COMMERCIAL & CONSUMER**  
**EQUIPMENT DIVISION**

---

**SelectSpray Attachment for ProGator**  
**HD200 and HD300**

OMTCU26461 A1

**OPERATOR'S MANUAL**



**JOHN DEERE**

**Original Instruction**

All information, illustrations and specifications in this manual are based on the latest information at the time of publication. The right is reserved to make changes at any time without notice.

**COPYRIGHT© 2011**  
**Deere & Co.**

**John Deere Worldwide Commercial and Consumer Equipment Division**

**All rights reserved**  
**Previous Editions**  
**COPYRIGHT© 2009**

**North American Version**  
**Litho in U.S.A.**

---

---

# Introduction

---

---

## Table of Contents

Introduction.....	1
Product Identification.....	1
Safety Labels.....	3
Safety.....	5
Preparing Vehicle.....	7
Assembly.....	7
Removing and Storing.....	14
Installing.....	20
Operating - Controls.....	22
Operating.....	23
Optional Attachments & Kits.....	38
Service.....	41
Troubleshooting.....	56
Specifications.....	57
Getting Quality Service.....	57

---

---

## Introduction

### Using Your Operator's Manual

Read this entire operator's manual, especially the safety information, before operating.

This manual is an important part of your machine. Keep all manuals in a convenient location so they can be accessed easily.

Use the safety and operating information in the attachment operator's manual, along with the machine operator's manual, to operate and service the attachment safely and correctly.

If your attachment manual has a section called Preparing the Machine, it means that you will have to do something to your tractor or vehicle before you can install the attachment. The Assembly and Installation sections of this manual provide information to assemble and install the attachment to your tractor or vehicle. Use the Service section to make any needed adjustments and routine service to your attachment.

If you have any questions or concerns with the assembly, installation, or operation of this attachment, see your local John Deere dealer or call the John Deere Customer Contact Center at 1-800-537-8233 for assistance.

Warranty information on this John Deere attachment can be found in the warranty that came with your John Deere tractor or vehicle.

---

---

## Product Identification

### Product Compatibility

The HD200 and HD300 Sprayer Attachments are compatible with ProGator™ utility vehicles.

### Record Identification Numbers

HD200 Serial Number - (050001- )

HD300 Serial Number - (025001- )

If you need to contact an Authorized Service Center for information on servicing, always provide the product model and serial number.

You will need to locate the model and serial number for the attachment and record the information in the spaces provided below.

# Product Identification

---

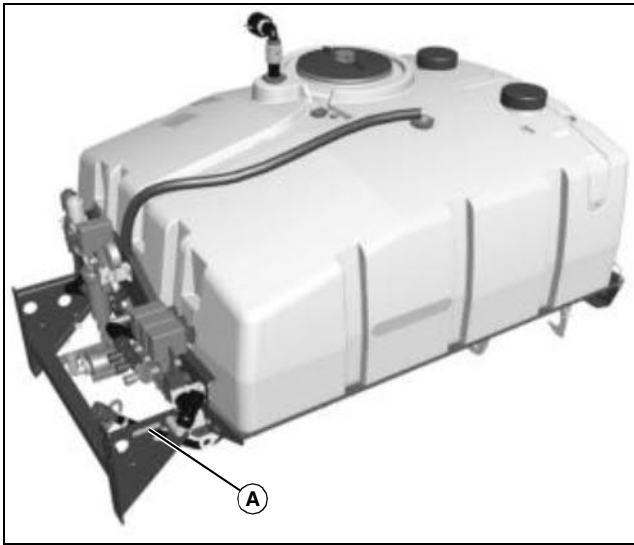

MX42625

DATE OF PURCHASE:

DEALER NAME:

DEALER PHONE:

PRODUCT SERIAL NUMBER (A):

-----

**<https://www.ebooklibonline.com>**

Hello dear friend!

Thank you very much for reading.

Enter the link into your browser.

The full manual is available for immediate download.

**<https://www.ebooklibonline.com>**

# Safety Labels

## Safety Labels



### Understanding The Machine Safety Labels

The machine safety labels shown in this section are placed in important areas on your machine to draw attention to potential safety hazards.

On your machine safety labels, the words DANGER, WARNING, and CAUTION are used with this safety-alert symbol. DANGER identifies the most serious hazards.

The operator's manual also explains any potential safety hazards whenever necessary in special safety messages that are identified with the word, CAUTION, and the safety-alert symbol.

There can be additional safety information contained on parts and components sourced from suppliers that is not reproduced in this operator's manual.

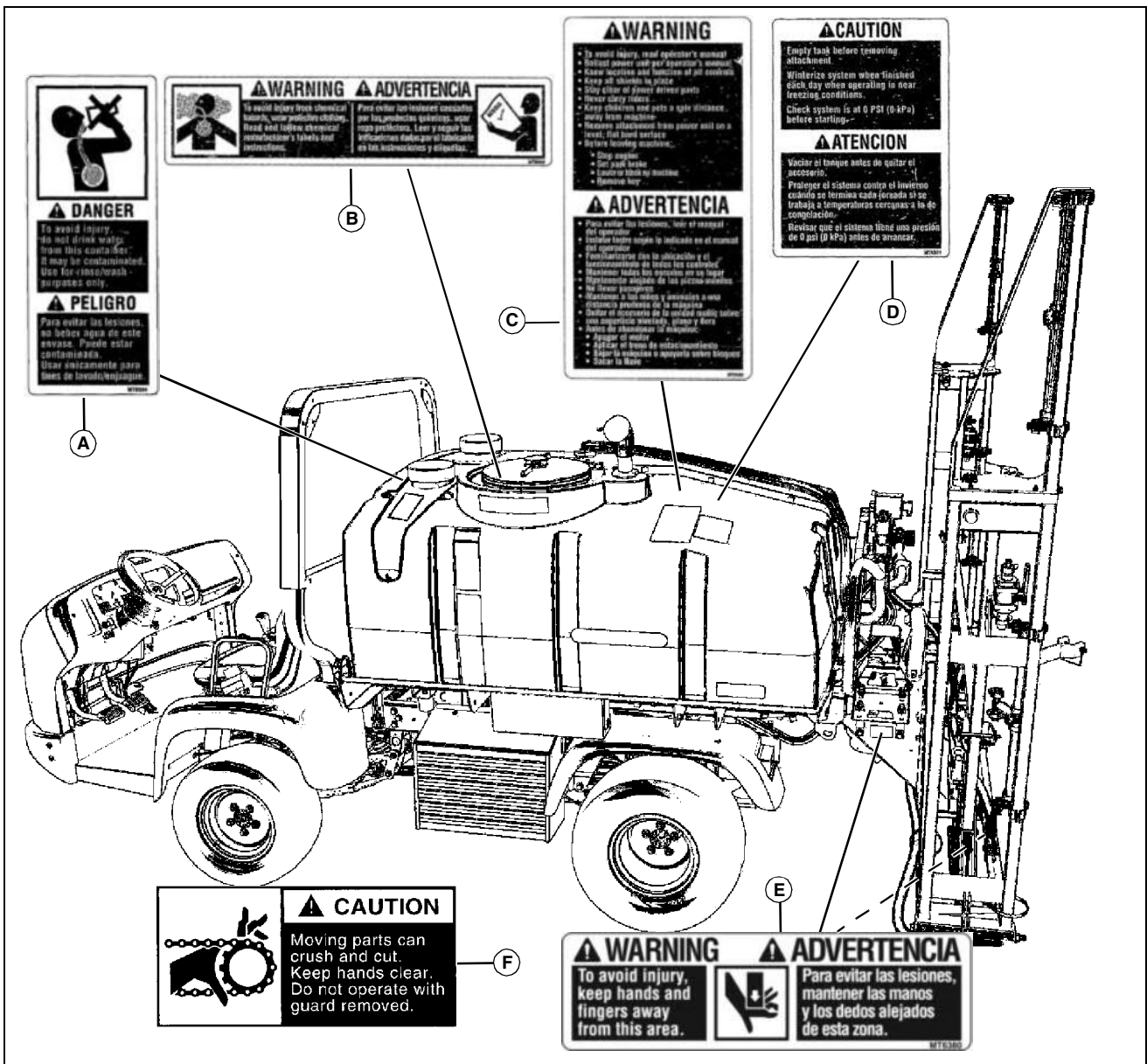

MX42169

complete text of safety label message following this illustration. HD200 model shown.

Picture Note: Use label number listed in table below to locate

# Safety Labels

- A- DANGER MT6304
- B- WARNING MT6302
- C- WARNING MT6300
- D- CAUTION MT6301
- E- WARNING MT6380
- F- CAUTION MX3605 (On optional hose reel kit)

## WARNING MT6300



MT6300

- To avoid injury, read operator's manual.
- Ballast power unit per operator's manual.
- Know location and function of all controls.
- Keep all shields in place.
- Stay clear of power driving parts.
- Never carry riders.
- Keep children and pets a safe distance away from machine.
- Remove attachment from power unit on a level, flat, hard surface.
- Before leaving machine:
  - Stop engine.
  - Set park brake.
  - Lower or block up machine.
  - Remove key.

## CAUTION MT6301



MT6301

Empty tank before removing attachment.

Winterize system when finished each day when operating in near freezing conditions.

Check system is at 0 PSI (0 kPa) before starting.

## WARNING MT6302



MT6302

To avoid injury from chemical hazards, wear protective clothing. Read and follow chemical manufacturer's labels and instructions.

## DANGER MT6304



MT6304

To avoid injury, do not drink water from this container. It may be contaminated. Use for rinse/wash purposes only.

# Safety

## Warning



MT6380

- To avoid injury, keep hands and fingers away from this area.

## WARNING MT4163



MT4163

**Picture Note:** For optional electric actuator kit.

To avoid injury, keep hands and fingers away from this area.

## CAUTION MX3605

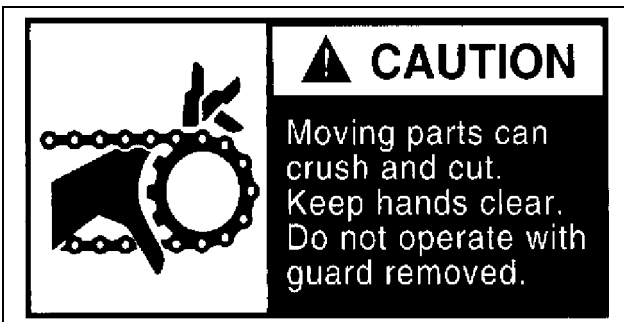

MX3605

**Picture Note:** For optional electric hose reel kit.

Moving parts can crush and cut. Keep hands clear. Do not operate with guards removed.

## Safety

### Read Safety in Machine Operator's Manual

Read the general safety operating precautions in your machine operator's manual for additional safety information.

### Operate Safely

- Read the machine and attachment operator's manual carefully. Be thoroughly familiar with the controls and the proper use of the equipment. Know how to stop the machine and disengage the controls quickly.
- Do not let children or an untrained person operate machine.
- Make any necessary adjustments before you operate. Never attempt to make any adjustments while the engine is running, unless if

recommended in adjustment procedure.

- Take all possible precautions when leaving the machine unattended. Shut off the engine before making any repairs, adjustments, or inspections. Lower the attachment, lock the parking brake, stop the engine, and remove the key.
- Look behind machine before you back up. Back up carefully.
- Do not let anyone, especially children, ride on machine or attachment. Riders are subject to injury such as being struck by foreign objects and being thrown off. Riders may also obstruct the operator's view, resulting in the machine being operated in an unsafe manner.
- Use only attachments and accessories approved by the manufacturer of this product.
- If the machine vibrates abnormally, stop the engine and check immediately for the cause. Vibration is generally a warning of trouble.
- Always refer to the Storage section of the operator's manual for important details if storing this product for a long period of time.
- Keep people and pets out of the work area. Stop machine if anyone enters the area.
- If you hit an object, stop the machine and inspect it. Make repairs before you operate. Keep machine properly maintained and in good working order. Keep all shields and guards in place.

• Always inspect the sprayer completely before and after each use. Before pressurizing the system, check to be sure all fittings and hoses are tightly installed. Be sure guards and shields are in good condition and fastened in place. Make any necessary adjustments before you operate.

- Never use the sprayer during windy conditions.

• Always release pressure in the system before filling, cleaning or servicing the sprayer.

• Do not put nozzle tip or other sprayer parts to your lips to blow out dirt. Use compressed air.

• If the sprayer is mounted to the bed of a utility vehicle, never raise the bed with the sprayer tank filled completely. Drain tank to below lowest fill line before raising for service or other reason.

### Parking Safely

1. Stop vehicle on a level surface, not on a slope.
2. Lock park brake.
3. Stop engine.
4. Remove key.
5. Before you leave the operator's seat, wait for engine and all moving parts to stop.
6. Disconnect the negative battery cable or remove the spark plug wire (for gasoline engines) before servicing the machine.

### Mix and Handle Chemicals Safely

- It is best to wear full cover clothing and always wear protective goggles and rubber gloves to protect yourself while handling chemicals.
- Follow instructions on chemical container labels.
- Open all chemical containers carefully, using proper tools.
- Open, pour, weigh and mix chemicals in a well-ventilated area.
- Reserve all equipment used for the application of chemicals exclusively for that purpose.
- Prohibit all smoking, drinking and eating food in chemical-handling area.
- It is a good practice to take a soapy shower immediately after the using

# Safety

the sprayer to apply chemicals.

- Wash all clothing worn when using chemicals separately in the laundry after spraying is completed.

## Read Chemical Container Label

- Chemicals can be dangerous. Improper selection or use can injure persons, animals, plants, soils or other property. Select the right chemical for the job and handle and apply with care.
- Read the instructions, precautions, and warnings on the container label before opening. Use the product strictly according to label directions for specific applications, in the amounts specified, at the times specified and only when needed.
- Keep the container closed tightly except when preparing the mix.
- Do not remove labels from chemical containers. Store all chemicals in their original containers.
- Do not mix chemicals unless stated on the container label.
- Store chemicals when not in use according to the container label.

## Handle Chemical Products Safely

- Direct exposure to hazardous chemicals can cause serious injury. Potentially hazardous chemicals used with John Deere equipment include pesticides, herbicides and fungicides.
- A Material Safety Data Sheet (MSDS) provides specific details on chemical products: physical and health hazards, safety procedures, and emergency response techniques.
- The MSDS should be obtained from the chemical dealer at the time of the chemical purchase.
- Check the MSDS before beginning any job using a hazardous chemical. Know exactly what the risks are and how to do the job safely. Always wear recommended personal protection equipment.

## Practice Safe Maintenance

- Only qualified, trained adults should service this machine.
- Understand service procedure before doing work. Keep area clean and dry.
- Do not operate the engine in a confined space where dangerous carbon monoxide fumes can collect.
- Never lubricate, service or adjust the machine or attachment while it is moving. Keep safety devices in place and in working condition. Keep hardware tight.
- Keep hands, feet, clothing, jewelry, and long hair away from any moving parts, to prevent them from getting caught.
- Lower any attachment completely to the ground or to an existing attachment mechanical stop before servicing the attachment. Disengage all power and stop the engine. Lock park brake and remove the key. Let machine cool.
- Disconnect battery or remove spark plug wire (for gasoline engines) before making any repairs.
- Before servicing machine or attachment, carefully release pressure from any components with stored energy, such as hydraulic components and springs.
- Release hydraulic pressure by lowering attachment or cutting units to the ground or to a mechanical stop and move hydraulic control levers.
- Securely support any machine or attachment elements that must be raised for service work. Use jack stands or lock service latches to support components when needed.

- Never run engine unless park brake is locked.
- Keep all parts in good condition and properly installed. Fix damage immediately. Replace worn or broken parts. Replace all worn or damaged safety and instruction decals.
- Check all hardware at frequent intervals to be sure the equipment is in safe working condition.
- Do not modify machine or safety devices. Unauthorized modifications to the machine or attachment may impair its function and safety.

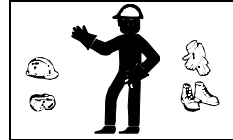

## Wear Appropriate Clothing

- Wear close fitting clothing and safety equipment appropriate for the job.
- Certain operating conditions may dictate that the operator and any passenger wear appropriate safety equipment while operating the vehicle. Be prepared for any existing and potential conditions before operating machine.
- Local safety or insurance regulations may require additional safety equipment such as eye protection or a hard hat.
- Always wear substantial footwear and long trousers. Do not operate the equipment when barefoot or wearing open sandals.
- Wear proper clothing and safety equipment while handling chemicals or using the sprayer. Refer to the MSDS for the chemicals being used to be sure the proper personal protection equipment is being used.



## Avoid High Pressure Fluids

- Hydraulic hoses and lines can fail due to physical damage, kinks, age, and exposure. Check hoses and lines regularly. Replace damaged hoses and lines.
- Hydraulic fluid connections can loosen due to physical damage and vibration. Check connections regularly. Tighten loose connections.
- Escaping fluid under pressure can penetrate the skin causing serious injury. Avoid the hazard by relieving pressure before disconnecting hydraulic or other lines. Tighten all connections before applying pressure.
- Search for leaks with a piece of cardboard. Protect hands and body from high pressure fluids.
- If an accident occurs, see a doctor immediately. Any fluid injected into the skin must be surgically removed within a few hours or gangrene may result. Doctors unfamiliar with this type of injury should reference a knowledgeable medical source. Such information is available from Deere & Company Medical Department in Moline, Illinois, U.S.A. Information may be obtained in the United States and Canada only by calling 1-800-822-8262.

## Dispose of Chemicals Properly

- Proper disposal of excess spray material is very important. If you have excess tank solution, it is best to dilute it with water and apply it to the area you previously treated.
- Never dump solution into a drain or near a lake or stream.
- Chemicals containers should be triple-rinsed, with the rinse water added to the sprayer tank. Do not burn empty chemical containers. Dispose of containers at recycling centers.

## Handling Waste Product and Chemicals

Waste products, such as, used oil, fuel, coolant, brake fluid, and batteries, can harm the environment and people:

- Do not use beverage containers for waste fluids - someone may drink from them.

# Preparing Vehicle

• See your local Recycling Center or authorized dealer to learn how to recycle or get rid of waste products.

• A Material Safety Data Sheet (MSDS) provides specific details on chemical products: physical and health hazards, safety procedures, and emergency response techniques. The seller of the chemical products used with your machine is responsible for providing the MSDS for that product.

## Preparing Vehicle

### Preparing the Machine

#### Machine Requirements

Your machine must be equipped with the Auxiliary Hydraulic Kit for operation of the sprayer pump. If your machine is equipped with a PTO control lever, two quick-couplers at the rear of the machine, an auxiliary tank and oil cooler, the Auxiliary Hydraulic Kit is installed.

Additional parts and/or modifications are required when using the HD300 SelectSpray attachment:

- Four post ROPS.
- Wide tires with tire pressure adjusted to 110 kPa (16 psi).
- Front and rear heavy duty springs.

#### Prepare for Assembly

1. Park machine safely.
2. Follow instructions in your machine operator's manual to remove the cargo box.
3. Remove any attachment that uses the hydraulic lift or rear pivots.

## Assembly

### Control Box Mounting Components

Qty.	Description
1	Bracket, Upper
1	Bracket, Lower
1	Washer, Wave
1	Pin, Quick-Lock
2	Bolt, M8x55
2	M8, Locknuts
2	Bolt, 1/4-20 x 3/4 in.
2	Washer, 1/4 in.
2	Nut, 1/4-20
1	Pivot, Control Box
1	Bolt, M8x75
2	Nut, M8
2	Washer, Friction

### Tank Components

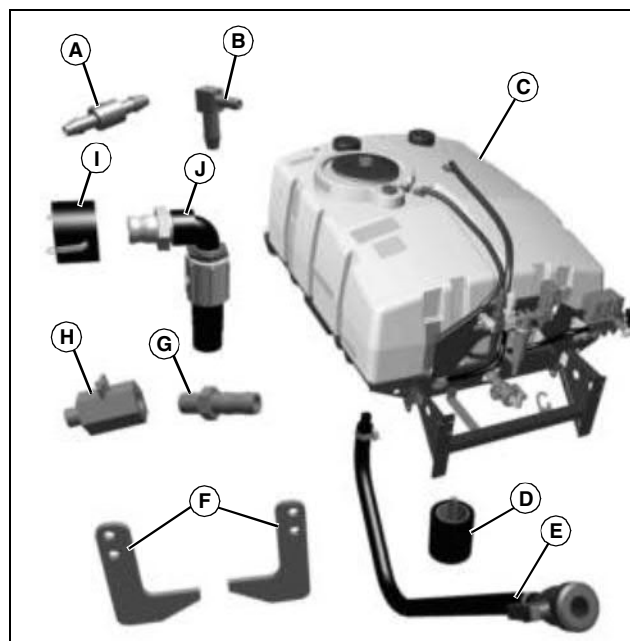

MX42214

Qty	Description
1	Check Valve, 1/4 in. (A)
1	Fitting, Barbed Hose, 1/4 in. (B)
1	Tank Assembly, Sprayer (C)
2	Down Stops (55 mm) (D)
1	Hose Assembly, Tank Drain (E)
2	Clamp, Frame (F)
1	Fitting, Barbed, 1/2 MPT x 3/8 HB (G)
1	Valve (H)
1	Cap, Dust (I)
1	Assembly, Filler (J)
1	Bracket, Support*
6	Nut, Nylock, M10
6	Capscrew, Hex Head, M10x35
1	Washer, Flat, M26
1	Clamp, Hose, 1/2 in.
1	Elbow, 1/2 FTP x 1/2 MPT
1	Hose, 3/8 in. x 12 in.
1	Hose, Clear
4	Clamp, Hose, 3/8 in.
2	Screw, M6x60*

# Assembly

Qty	Description
2	Locknut, M6*
3	J Clips
1	Elbow, Threaded, 90 Degree
1	Elbow, Hose Barb, 90 Degree

\*Parts for model HD300 only.

## Electrical Components

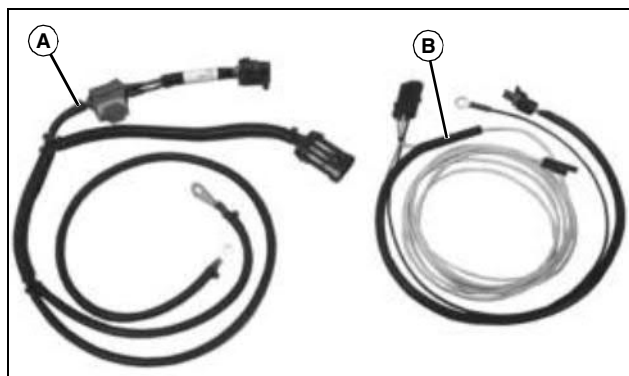

MX42254

Qty	Description
1	Power Harness (A)
1	Console Wire Harness (B)
8	Tie Strap

## Pump and Hydraulic Components\*

Qty	Description
1	Fitting, Elbow
2	Hose Assembly, Hydraulic
1	Ball Valve, Three-Way
1	Fitting, Check Valve
3	Fitting, Adapter
1	Dust Cap, Red
1	Dust Cap, Yellow
1	Hose, 1 in. dia.
2	Quick Coupler, Male
2	Clamp, Hose

\*Pump is included in separate kit.

## Personal Wash Tank Components

Qty.	Description
1	Elbow
1	Ball Valve
1	Hose Barb
1	Hose
1	Hose Clamp

## Install Control Box

### Install Mounting Arm

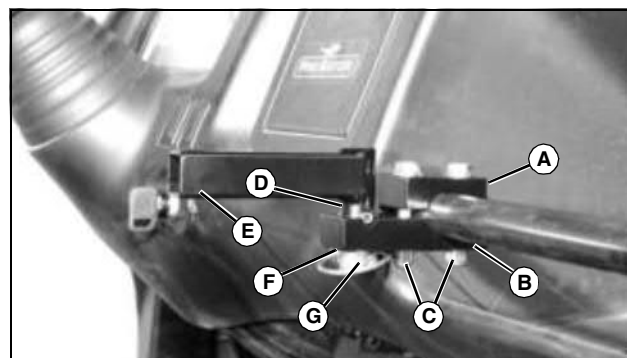

MX42110

1. Loosely install upper (A) and lower (B) mounting brackets to passenger grab bar with two M8x55 hex head bolts and locknuts (C).
2. Install post (D) on mounting arm (E) through lower mounting bracket with washer(s) (F) and quick-lock pin (G).

### Install Box

**NOTE: Control box is included in separate kit.**

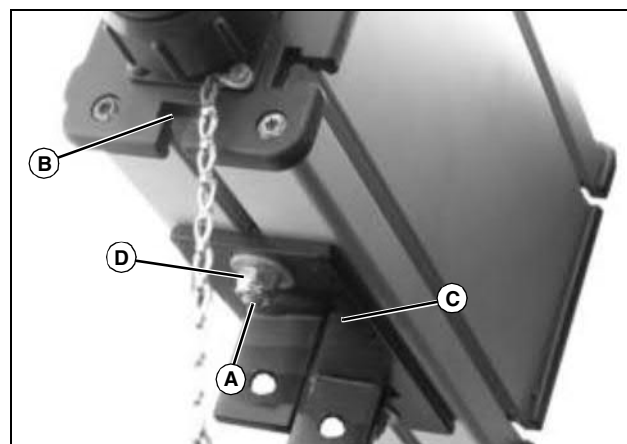

MX42111

1. Install two 1/4-20 x 3/4 in. bolts (A) into slot (B) at bottom of control box.
2. Install bolts (A) through control box bracket (C) with 1/4 in. washers and 1/4-20 nuts (D).

# Assembly

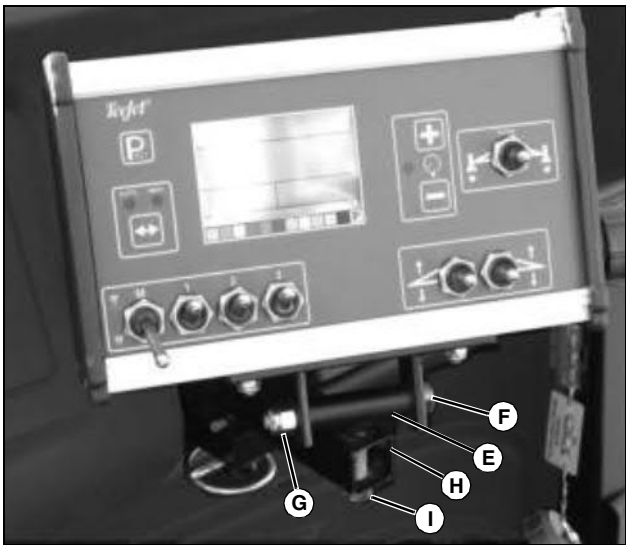

MX42112

**Picture Note: Auto Rate control box shown.**

3. Install pivot control box (E) on control box bracket with M8x75 hex head bolt (F) and M8 hex nut (G).
4. Install T connector on mounting arm (H) with friction washers and secure with M8 hex nut (I).
5. Adjust position of control box as desired and tighten all nuts.

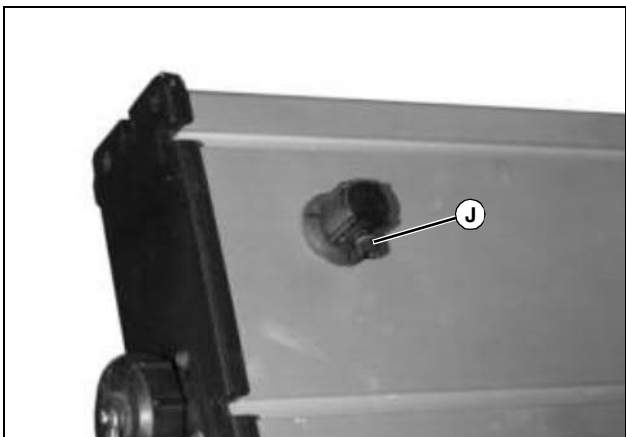

MX42183

6. Manual control box only: Follow instructions in control box kit to connect pressure line to pressure gauge fitting (J) on back of control box.

## Install Cylinder Support Bracket (HD300)

**NOTE: It is recommended that the cylinder support bracket be installed before installing the sprayer tank.**

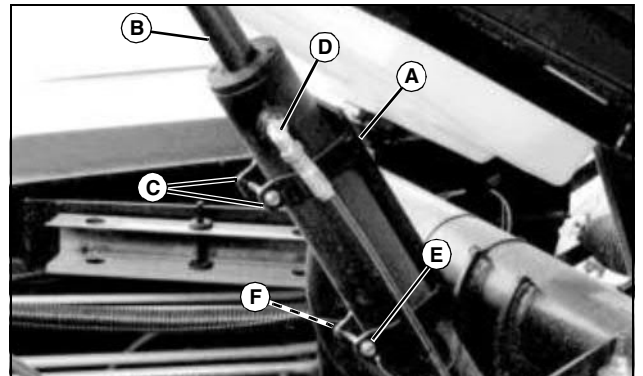

MX23106

1. Extend the lift cylinder far enough to slide the support bracket (A) over the rod of the cylinder (B).
2. Install the support bracket over the rod of the cylinder.
3. Align the two slots (C) of the support bracket with the upper hydraulic hose (D) of the cylinder then slide the support bracket over the base of the cylinder.
4. Loosely install two M6 X 60 screws (E) and two M6 lock nuts (F).
5. Position the support bracket with the flat surface facing up toward the tank and approximately 6 cm (2 1/2 in.) from the end of the cylinder. Tighten fasteners securely.
6. Raise and lower the tank to check for clearance between the support bracket and the sprayer frame. Make adjustments to support bracket if needed.

## Install Sprayer Tank



**CAUTION: Avoid injury! Machine component or attachment is heavy. Use a safe lifting device with correct load capacity rating to lift, install or remove component or attachment.**

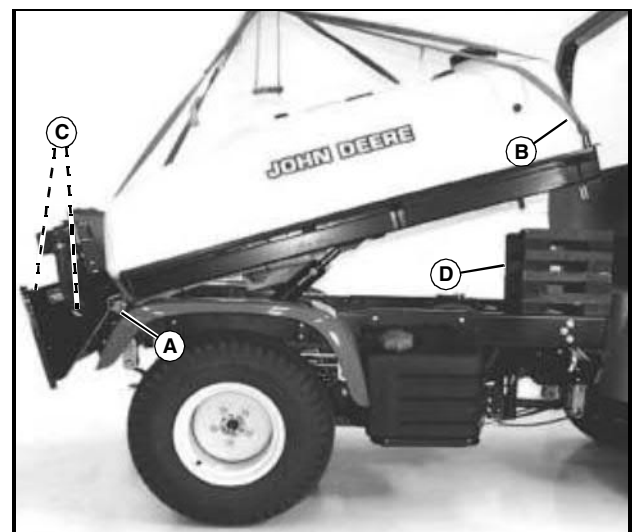

MX2956a

1. Install lift straps or chains to sprayer so unit is balanced upon hoisting. Do not directly connect to rear mounting holes (A).

# Assembly

2. Attach lift strap to lift loops (B) at front of sprayer frame.
3. Secure straps around rear of frame (C).
4. Install safety stand (D) between machine frame and sprayer frame.
5. Lift the tank/frame into position over machine frame as shown.

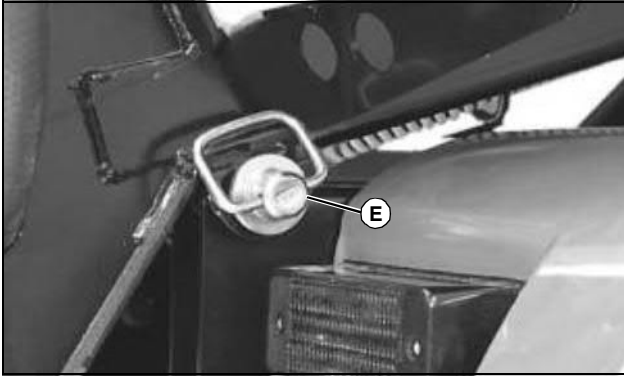

MX19928

6. Align mounting holes at rear of machine and install pivot pins (E) as shown. Secure pivot pins with quick-lock pins.

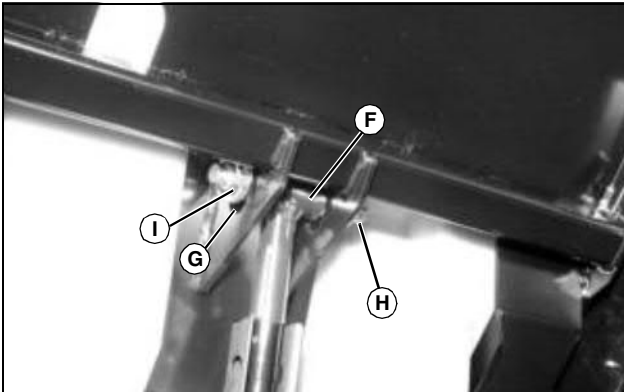

MX42247

7. Align hole in lift cylinder rod end (F) with hole in frame (G). Install connecting pin (H), and secure with M26 flat washer and spring locking pin (I).
8. Remove safety stand from between tank and machine frame.
9. Disconnect hoist from sprayer and completely lower tank using the lift cylinder lever.

## Install Power Harness

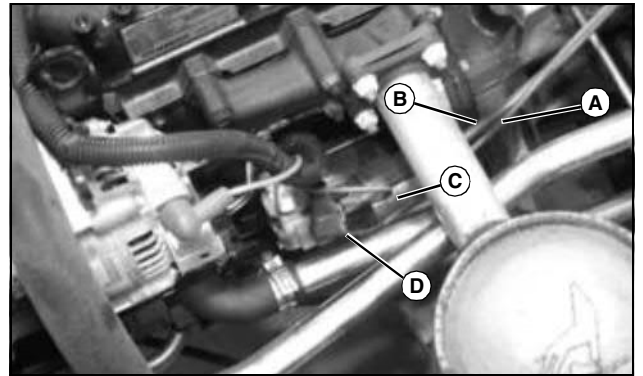

MX42107

1. Route sprayer power harness red cable (A) along red battery cable (B) to starter solenoid (C). Route cable away from potential sources of damage and secure with retainers.
2. Install ring terminal (D) of red cable to starter solenoid terminal "B".

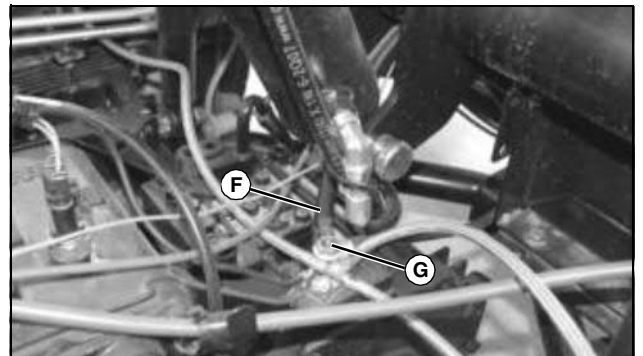

MX42108

3. Install ring terminal of power harness black ground cable (F) to transaxle ground bolt (G).

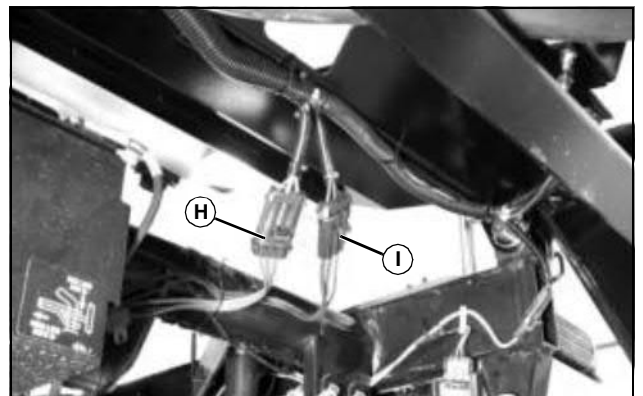

MX42109

4. Connect male power harness connector (H) and female ground connector (I) to matching connectors on sprayer main harness.

# Assembly

## Install Console Wire Harness

**NOTE:** The three-wire connector (A) on the front harness is for use with optional automatic rate control kit.

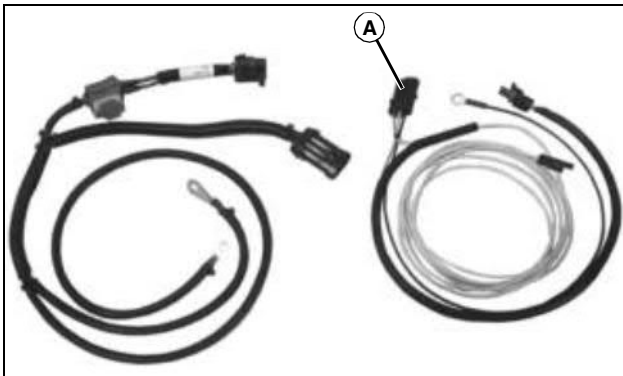

MX42254

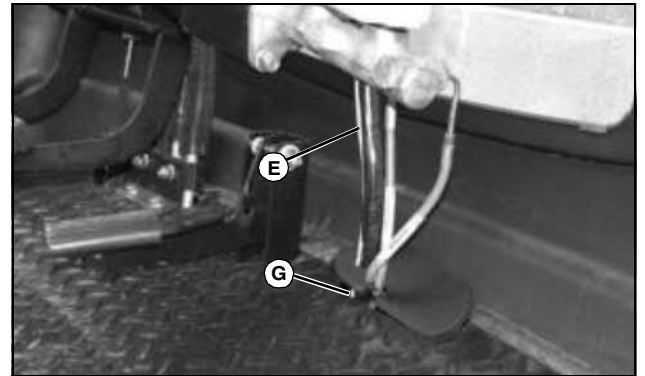

MX42104

5. Route yellow wire (E) along with machine harness under cab floor and through opening (G) at forward edge of cab floor.

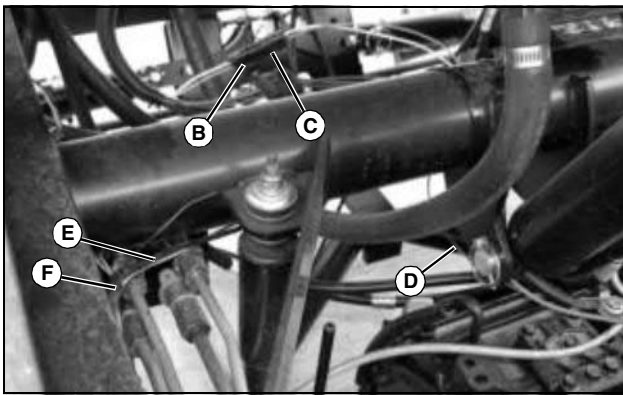

MX42101

1. Connect sprayer main harness pink and yellow wire connector (B) to console harness pink and yellow wire connector (C).
2. Route console harness pink wire (D) over transaxle.
3. Route console harness yellow wire (E) to machine harness (F) along right frame rail.

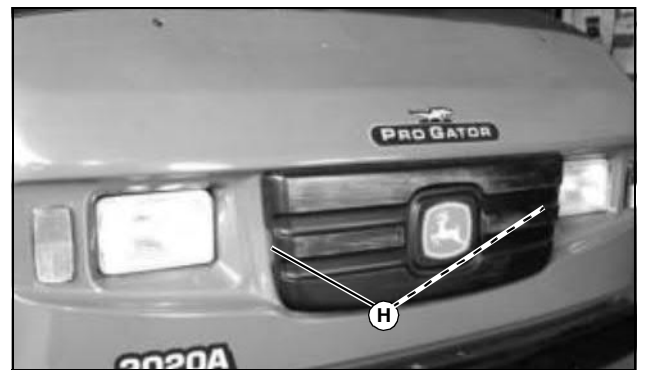

MX42105

6. Grasp grille at tabs (H) and pull outward to remove grille for access to wiring harness.

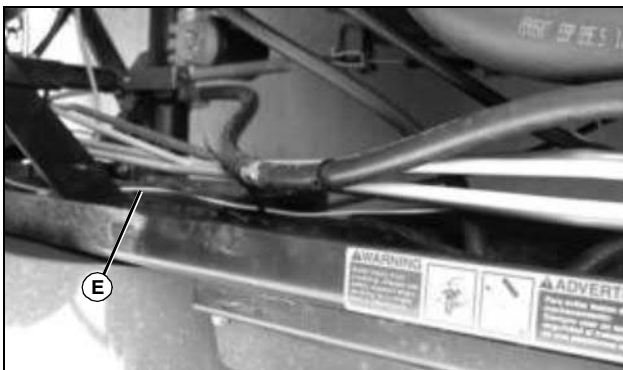

MX42103

4. Route console harness yellow wire (E) forward along machine harness inside right frame rail.

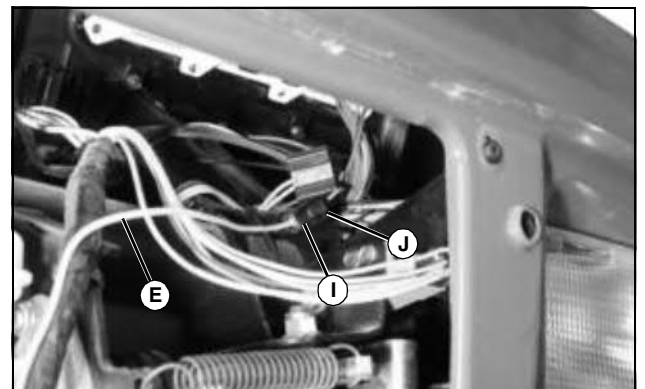

MX42106

7. Route yellow wire (E) upward along machine harness under dashboard.
8. Install connector (I) on yellow wire to machine harness connector (J).
9. Secure installed wires with wire ties.
10. Replace grille.

# Assembly

## Install Sprayer Tank Components

**NOTE:** For best results, apply a chemical-resistant pipe sealant to all threaded fittings.

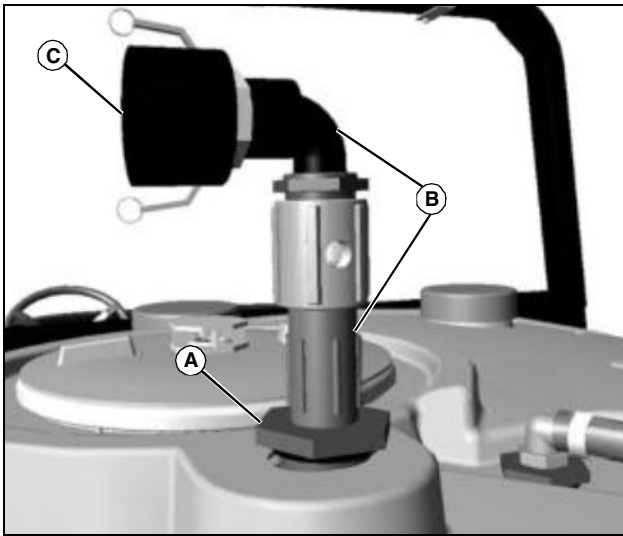

MX19970

1. Remove and discard plastic protective cap from fill port (A) on top side of tank.
2. Thread filler tube assembly (B) into fill port. Tighten completely, positioning quick-connect opening facing left side of tank as shown.
3. Install dust cap (C).

## Tank Drain Hose

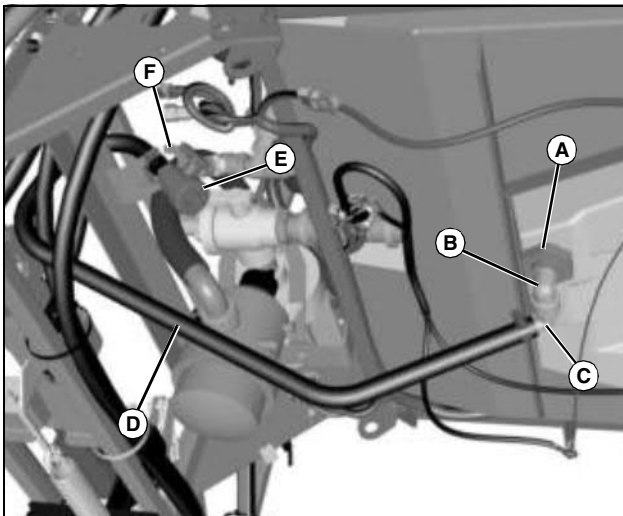

MX48583

1. Raise and properly support tank to access tank drain (A).
2. Install 90 degree threaded elbow (B) into tank drain.
3. Install 90 degree hose barb elbow (C) onto 90 degree threaded elbow.
4. Install drain tube assembly (D) onto 90 degree hose barb elbow.
5. Route drain hose assembly under machine rear frame crossmember, then up over hitch bracket and set drain valve (E) in cradle (F) as shown.

## Personal Wash Tank Hose

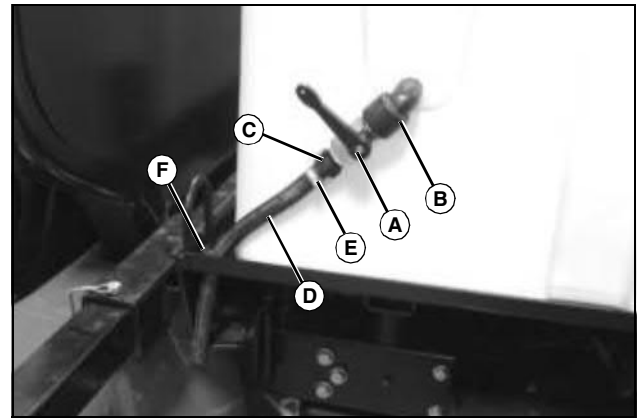

MX42618

1. Install ball valve (A) onto elbow (B).
2. Install hose barb (C) onto ball valve.
3. Install elbow assembly into threaded hole in left front corner of sprayer wash tank as shown.
4. Install hose (D) onto hose barb with hose clamp (E).
5. Route hose through hole (F) in sprayer frame.

## Connect Sprayer Main Harness to Control Box



MX42619

1. Remove tie strap holding section of main sprayer harness (A) to side of sprayer frame.
2. Route harness between sprayer and machine, and over plate in bottom half of ROPS frame.

# Assembly

## Connect Rear Wiring Harness

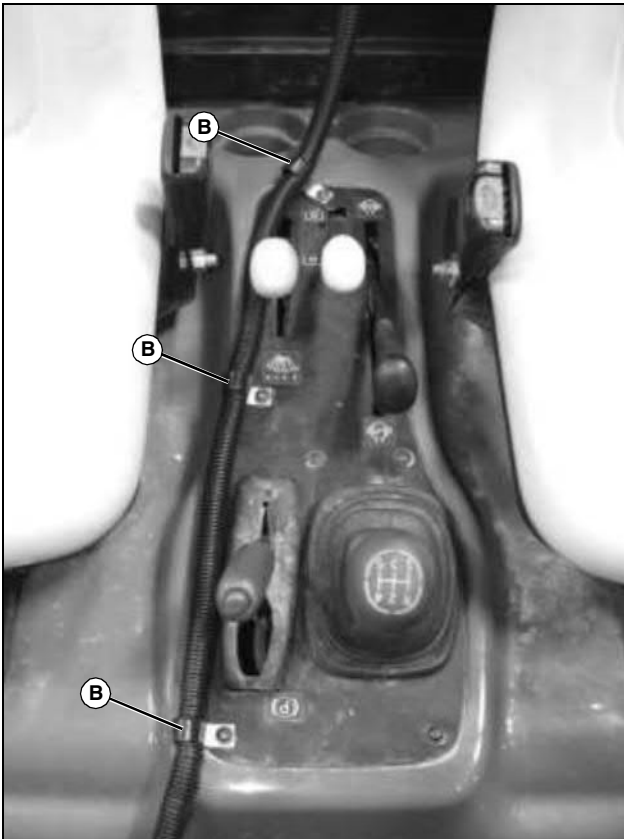

MX42620

3. Install J-clips (B) on screws in center control panel.
4. Install harness on J-clips and route to front of machine.



MX42200

5. Connect harness connector (C) to control box (D).

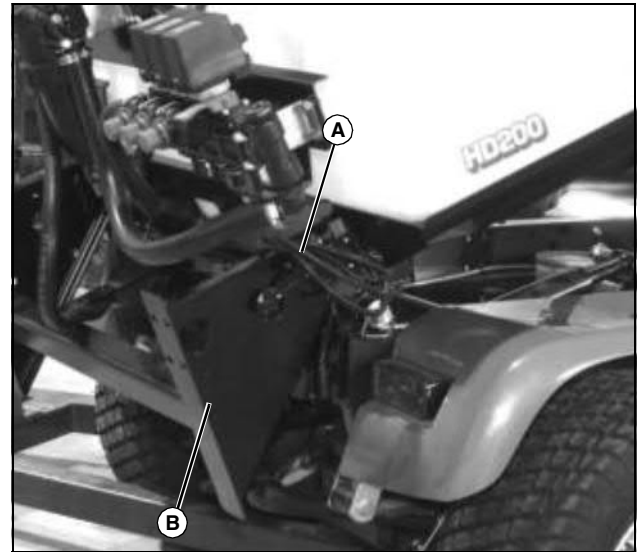

MX42330

1. Cut wire tie securing rear harness bundle (A) to rear corner of sprayer frame.

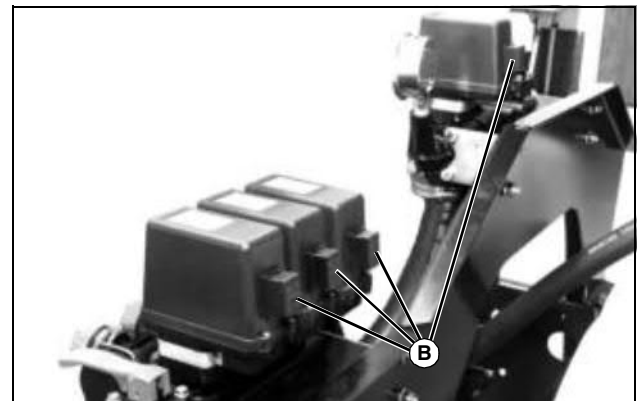

MX42255

2. Remove protective caps (B) from master and boom solenoid valve covers.

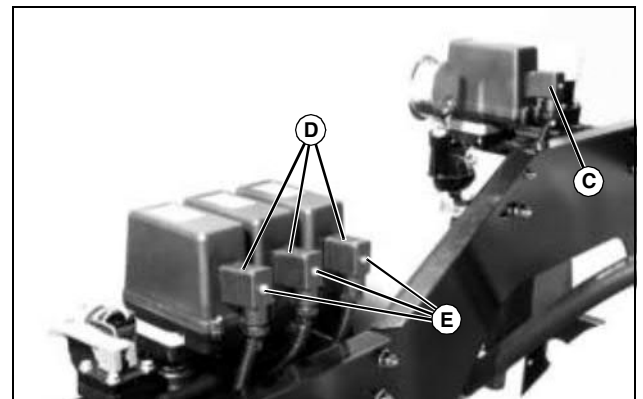

MX42256

3. Connect single harness plug (C) to master solenoid valve.
4. Connect multiple harness plugs (D) to boom solenoid valves in correct order from left to right.



**Suggest:**

**If the above button click is invalid.**

**Please download this document**

**first, and then click the above link**

**to download the complete manual.**

**Thank you so much for reading**

# Removing and Storing

- Connect the long solenoid lead to the outer solenoid.
  - Connect the middle solenoid lead to the middle solenoid.
  - Connect the short solenoid lead to the inner solenoid.
- Secure each plug to valve using screws (E).
  - If equipped with optional sprayer equipment, make all necessary electrical and hose connections at this time. See installation instructions provided with your optional equipment.
  - If not equipped with optional sprayer equipment, route the excess and unused sprayer harness leads behind back panel below solenoid manifold and secure with tie straps.

## Install Frame Clamps

Sprayer can be mounted on earlier and current model ProGators. The difference between models requires the use of different mounting holes on the frame bracket. Use the following illustration as a guide for selecting the appropriate mounting hole for machine:

**Upper and lower mounting holes (A) for earlier models (2020, 2030).**

**Upper and lower mounting holes (B) for current models (2020A, 2030A).**

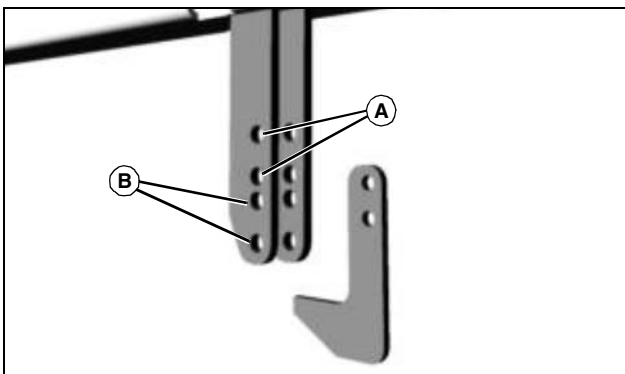

MX23109

## Installing Frame Clamps to Sprayer

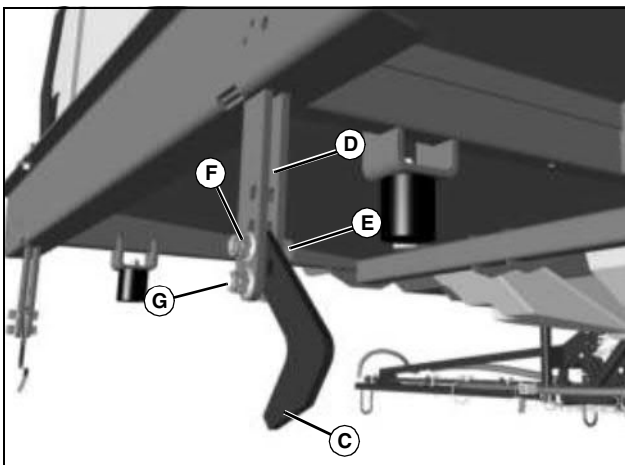

MX42163

### Picture Note: Current mounting shown.

- Place frame clamp (C) onto frame bracket (D); install M10x35 bolt (E) into the appropriate mounting hole. Install M10 locknut (F) onto bolt but do not tighten.
- Pivot frame clamp up and install M10x35 bolt (G) in appropriate mounting hole. Install locknut onto bolt but do not tighten. The frame

clamp should stay in this open position to clear the ProGator frame when lowering sprayer.

## Securing Sprayer to Frame

Once sprayer is installed, it should be secured to the ProGator frame before operating.

- Lower sprayer.

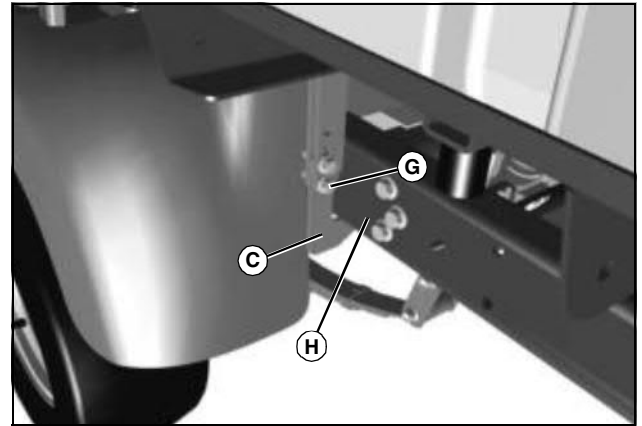

MX42397

- Remove bottom M10 locknut and M10x35 bolt so frame clamp (C) can pivot down to secure sprayer to ProGator frame (H).
- Install M10x35 bolt (G) through frame bracket and secure with M10 locknut.
- Tighten fasteners securely.

# Removing and Storing

## Prepare Machine for Removal

- Park machine safely.
- Ensure sprayer tank is empty to help reduce and balance load.
- Lock boom wings in upright position.

## Disconnect Hydraulic Hoses



**CAUTION: Avoid injury! Escaping fluid under pressure can penetrate skin and cause serious injury, including gangrene.**

- Relieve pressure before disconnecting hydraulic or other pressurized lines.
- Use a piece of cardboard to search for leaks. Do not expose hands or body to high pressure fluids.
- Tighten all connections before applying pressure.

- Disconnect sprayer hydraulic lines from yellow and red female quick-couplers at rear of machine. Leave lift cylinder lines connected.
- Install dust caps on sprayer hydraulic lines and quick disconnect couplers.

**<https://www.ebooklibonline.com>**

Hello dear friend!

Thank you very much for reading.

Enter the link into your browser.

The full manual is available for immediate download.

**<https://www.ebooklibonline.com>**