

Lawn Tractors

S2546

Serial No. (020,001-)



Limited Edition

OPERATOR'S MANUAL

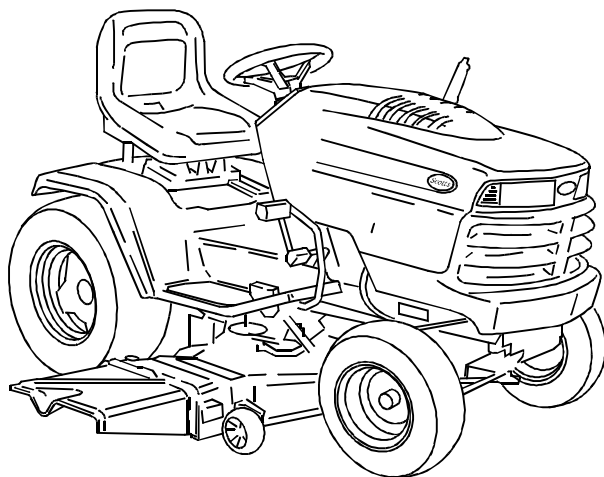

OMGX10545 F9

North American Version
Litho in U.S.A.

English

INTRODUCTION

THANK YOU for purchasing a Scotts product.

Read this manual and your attachment manual thoroughly. Failure to do so could result in personal injury or equipment damage.

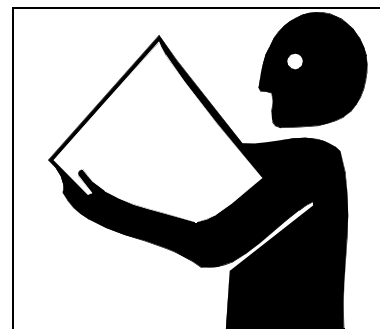

WARNING: The Engine Exhaust from this product contains chemicals known to the State of California to cause cancer, birth defects or other reproductive harm.

CALIFORNIA Proposition 65 Warning

This manual should be considered a permanent part of your machine and should remain with the machine when you sell it.

Measurements in this manual are metric units and their U.S. customary equivalents. RIGHT-HAND and LEFT-HAND sides are determined by facing in the direction the machine will travel when going forward. When you see a broken line arrow (----->), it indicates the part it is pointing to is hidden.

Record identification numbers below. Be sure to record all the numbers to help in tracing the machine if it is stolen. You also need to give these numbers to your dealer when you order parts.

DATE OF PURCHASE: _____

DEALER NAME: _____

DEALER PHONE: _____

TRACTOR SERIAL NUMBER (A), (Under seat):

ENGINE SERIAL NUMBER (B), (Right side of engine):

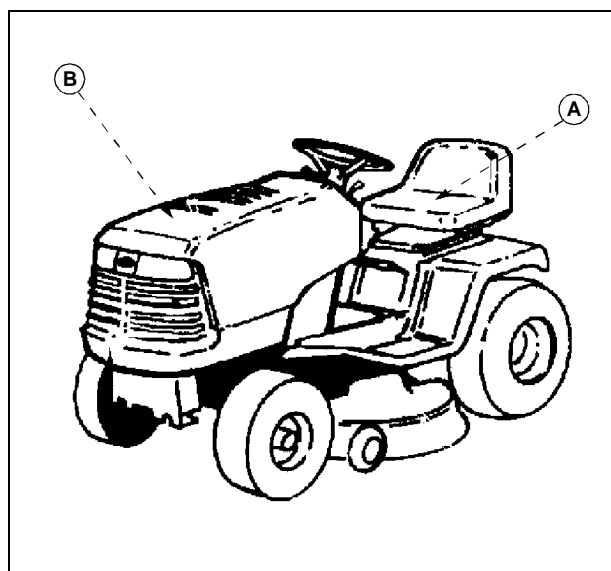

TABLE OF CONTENTS

Assembly	1
Safety Signs.....	4
Controls	6
Operating the Machine	7
Operating the Mower	23
Replacement Parts	29
Service Machine Safely	30
Service Interval Chart.....	32
Service Engine	34
Service Steering and Brakes	41
Service Mower.....	43
Service Electrical.....	49
Service Miscellaneous.....	55
Removing Mower.....	62
Installing Mower.....	64
Troubleshooting	66
Storing Machine.....	71
Specifications.....	74
Warranty	76
Index.....	82
Service Literature	85

All information, illustrations and specifications in this manual are based on the latest information at the time of publication. The right is reserved to make changes at any time without notice.

COPYRIGHT© 1999
Deere & Co.
John Deere Worldwide Commercial and
Consumer Equipment Division
Horicon, WI
All rights reserved

OMGX10545 F9

<https://www.ebooklibonline.com>

Hello dear friend!

Thank you very much for reading.

Enter the link into your browser.

The full manual is available for immediate download.

<https://www.ebooklibonline.com>

ASSEMBLY

Identify Parts

NOTE: There is an extra ignition key strapped to one of the seat suspension springs.

Bag of Parts:

- Operator's Manual
- Safety Video
- Key Chain
- Padded Key
- Hardware for Battery Cables

Check and Connect Battery



CAUTION: Prevent Battery Explosions:

- Keep sparks, lighted matches, and open flame away from the top of battery. Battery gas can explode.
- Never check battery charge by placing a metal object across the posts. Use a voltmeter or hydrometer.
- Do not charge a frozen battery; it may explode. Warm battery to 16° C (60° F)



Check Battery

Battery is filled with acid and charged when it left the factory. If necessary, charge the battery prior to delivery.

Locate label attached to battery. Find the service expiration date information (A).

If battery is put into service after date shown, charge the battery for a minimum of 1 hour at 6 - 10 amps.

Check battery voltage. Battery is fully charged at 12.6 volts.

Make sure battery is installed with the NEG (negative) side of the battery to the left and POS (positive) side of battery to the right. Battery should be held down securely with the battery hold-down strap.

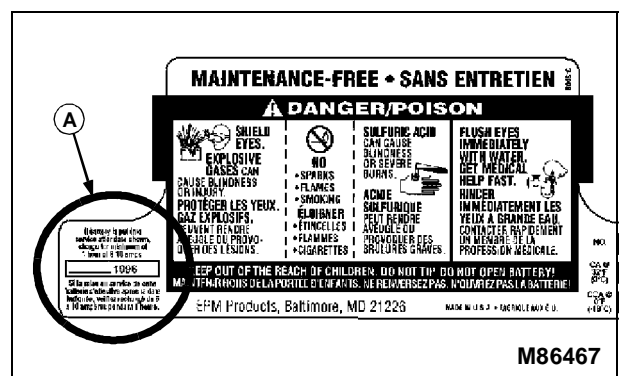

ASSEMBLY

Connect Battery

1. Remove and discard the RED positive (+) protective cap from the positive (+) battery terminal.
2. Connect RED positive (+) cable (A) to the battery POS (positive) terminal with carriage bolt and wing nut. Tighten securely. Apply petroleum jelly or silicone spray to terminal to prevent corrosion. Install the red terminal cover.
3. Remove and discard the BLACK (-) protective cap from the negative battery terminal.
4. Connect silver braided grounding cable (B) to the NEG (negative) terminal (C) with remaining carriage bolt and wing nut and tighten securely. Apply petroleum jelly or silicone spray to terminal to prevent corrosion.

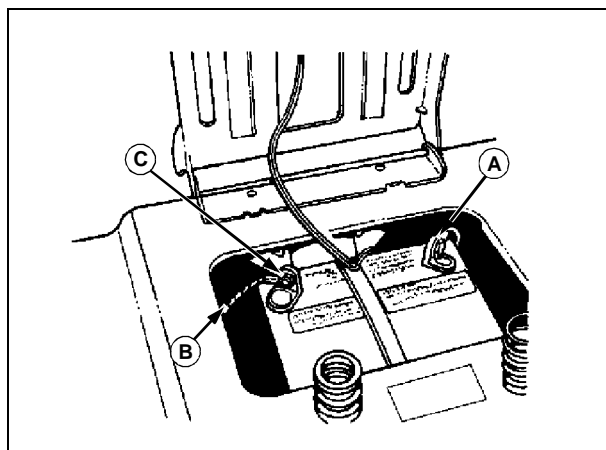

Check Tire Pressure

IMPORTANT: Tires are over-inflated during tractor assembly to improve bead sealing. During tractor set-up, be sure to check tire pressure and adjust if necessary.

Check tire pressure with an accurate gauge.

Adjust tire pressure to chart below:

Tire	Maximum Pressure
Front	97 kPa (14 psi)
Rear	69 kPa (10 psi)

ASSEMBLY

Check Engine Oil

IMPORTANT: To avoid engine damage, DO NOT run engine if oil level is below ADD mark.

1. Remove dipstick (A). Wipe with clean cloth.
2. Reinsert the dipstick into the tube and thread cap tightly onto fill tube. Remove dipstick to check oil level.
3. Oil must be between ADD and FULL marks.
4. Add oil to FULL mark if necessary. DO NOT overfill.
5. Install and tighten dipstick.

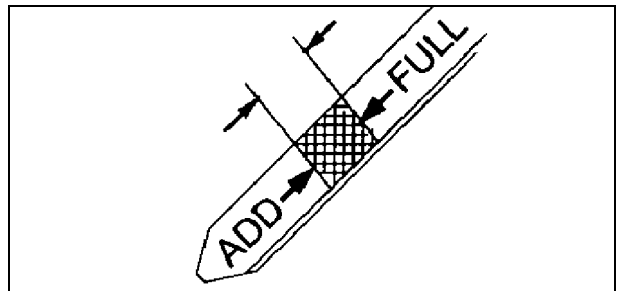
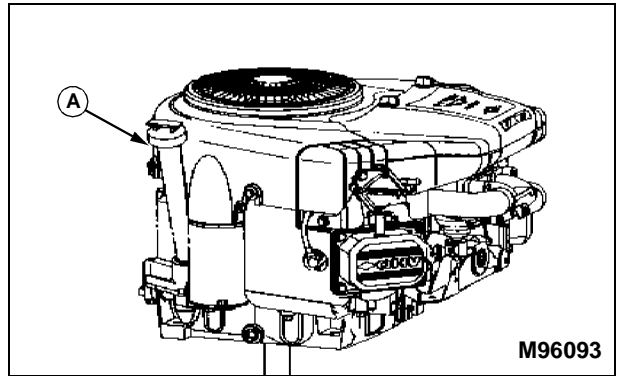

SAFETY SIGNS

Safety-Alert Symbol

Read and recognize safety information. Be alert to the potential for personal injury when you see this safety-alert symbol.

On your machine safety labels, the words DANGER, WARNING, and CAUTION are used with this safety-alert symbol. DANGER identifies the most serious hazards.

In this manual, the word CAUTION and this symbol call attention to safety messages.

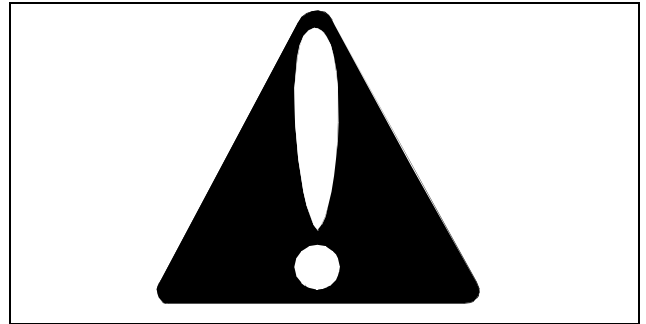

Certification

Your mower has been certified by an independent laboratory for compliance with American National Standard B-71.1-1998, "Safety Specifications" for Power Lawn Mowers, Lawn and Garden Tractors, and Lawn Tractors.

Machine Safety Labels

DANGER

AVOID SERIOUS INJURY OR DEATH

- Do not mow when children or others are around
- Do not mow in reverse
- Look down and behind before and while backing
- Never carry children

WARNING

AVOID SERIOUS INJURY OR DEATH

- Drive up and down slopes, not across
- Avoid sudden turns
- If machine stops going uphill, stop blade and back down slowly
- Keep safety devices (guards, shields, and switches) in place and working
- Read operator's manual
- When leaving machine:
 - Stop engine
 - Set park brake
 - Remove key

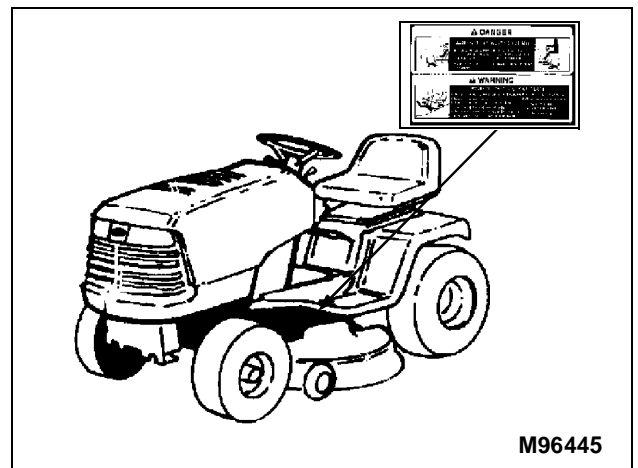

SAFETY SIGNS

DANGER/POISON

SHIELD EYES.

EXPLOSIVE GASES CAN CAUSE BLINDNESS OR INJURY.

NO

- SPARKS
- FLAMES
- SMOKING

SULFURIC ACID CAN CAUSE BLINDNESS OR SEVERE BURNS

FLUSH EYES IMMEDIATELY WITH WATER.

GET MEDICAL HELP FAST.

MAINTENANCE-FREE

KEEP OUT OF THE REACH OF CHILDREN. DO NOT TIP. DO NOT OPEN BATTERY!

Picture Note: Located on Battery under seat

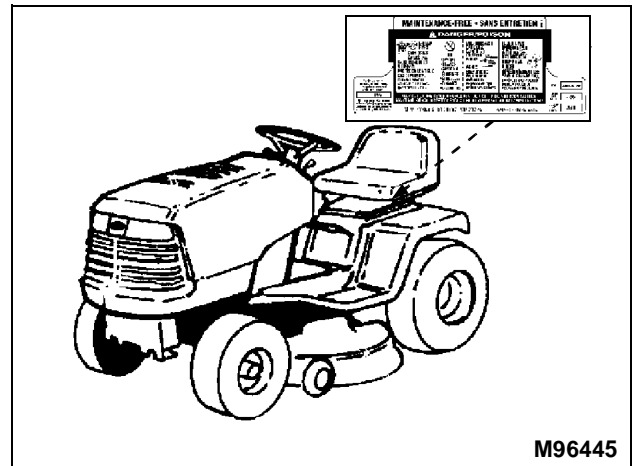

DANGER

ROTATING BLADE

DO NOT PUT HANDS OR FEET UNDER OR INTO MOWER WHEN ENGINE IS RUNNING

THROWN OBJECTS

BEFORE MOWING, CLEAR AREA OF OBJECTS THAT MAY BE THROWN BY BLADE

DO NOT OPERATE MOWER WITHOUT DISCHARGE CHUTE OR ENTIRE GRASS CATCHER IN PLACE

Picture Note: Located on Right-Hand side of deck

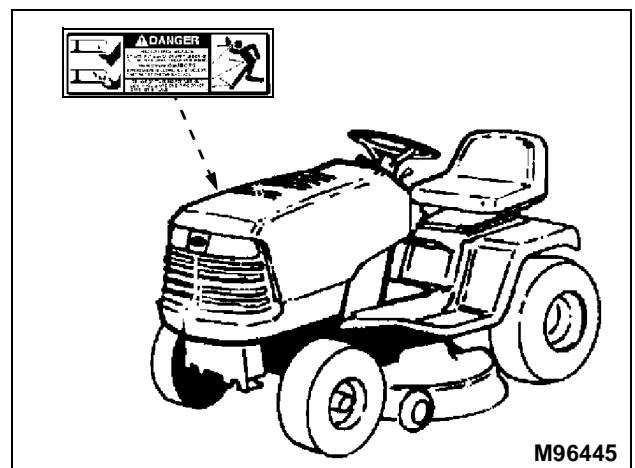

DANGER

ROTATING BLADE

DO NOT PUT HANDS OR FEET UNDER OR INTO MOWER WHEN ENGINE IS RUNNING

Picture Note: Located on Left-Hand side of deck

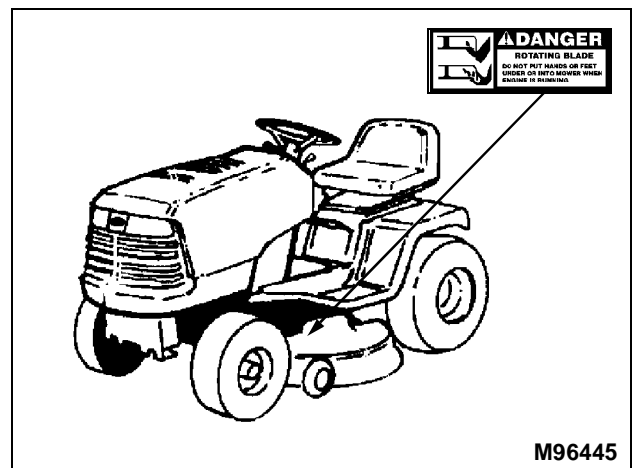

CONTROLS

Tractor Controls

- A - Choke Knob
- B - Throttle Control
- C - Reverse Implement Option Switch
- D - Attachment Lift Lever
- E - Locking Lever
- F - Free Wheeling Knob
- G - Ignition Switch
- H - Transmission Shift Lever
- I - Park Brake
- J - PTO Drive Lever
- K - Foot Pedal - Brake/Return to Neutral

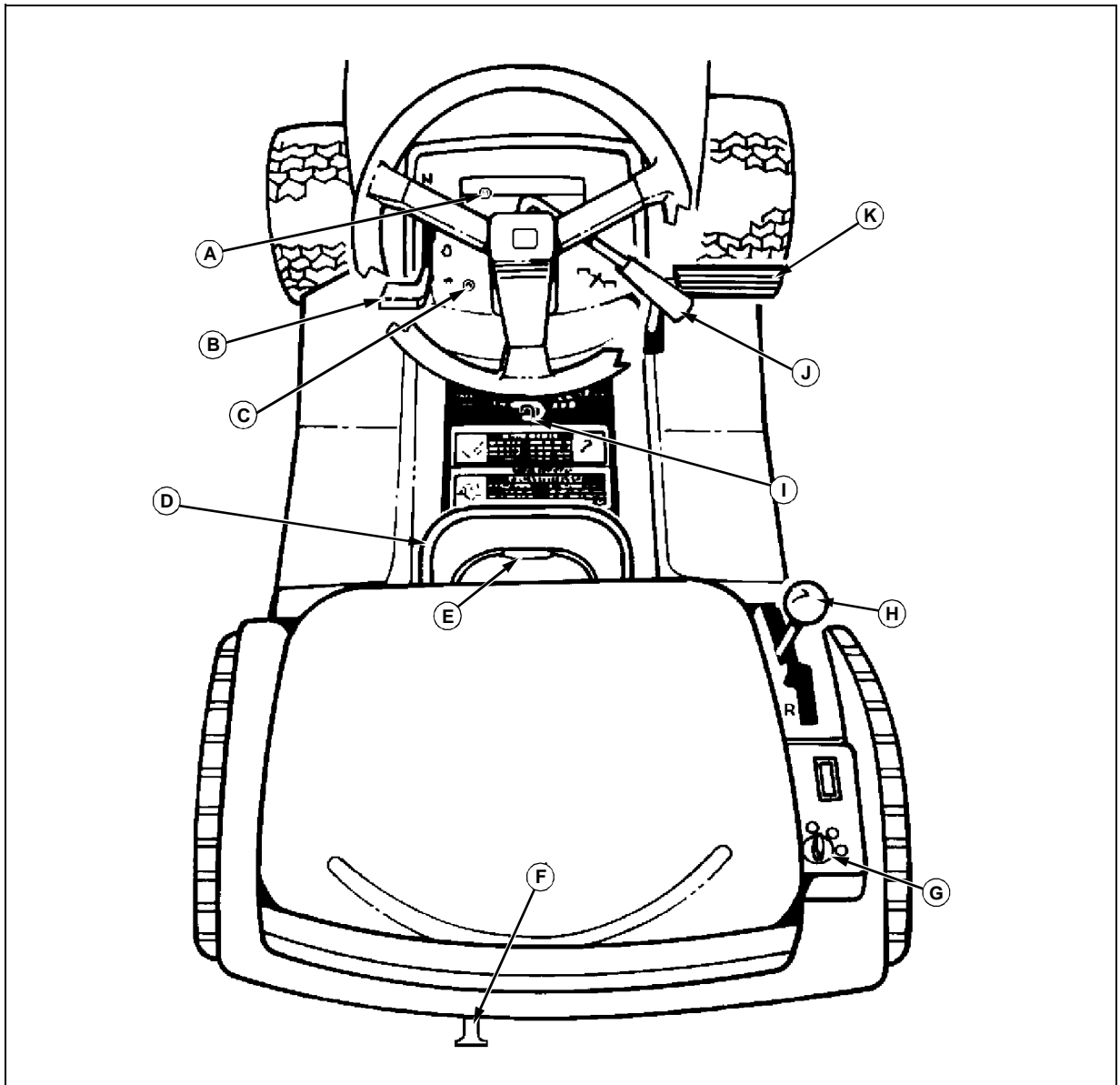

OPERATING MACHINE

Operate Safely

- In addition to reading your Operator's Manual, view your Mowing Safety Video.
- Check brake action before you operate. Adjust or service brakes as necessary.
- Inspect machine before you operate. Be sure hardware is tight. Repair or replace damaged, badly worn, or missing parts. Be sure guards and shields are in good condition and fastened in place. Make any necessary adjustments before you operate.
- Clear work area of objects that might be thrown. Keep people and pets out of the work area. Stop machine if anyone enters the area.
- If you hit an object, stop the machine and inspect it. Make repairs before you operate. Keep machine and attachments properly maintained and in good working order.
- DO NOT leave machine unattended when it is running.
- Only operate during daylight or with good artificial light.
- Be careful of traffic when operating near or crossing roadways.
- Do not wear radio or music headphones while operating the machine. Safe operation requires your full attention.

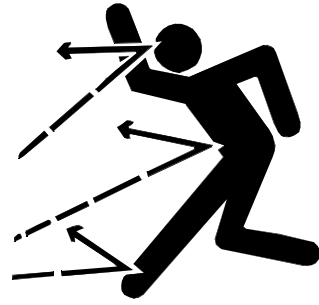

Park Safely

- Stop machine on a level surface, not on a slope.
- Disengage mower blades.
- Lower attachments to the ground.
- Engage park brake.
- STOP engine.
- Remove key.
- Before you leave the operator's seat, wait for engine and all moving parts to STOP.

OPERATING MACHINE

Rotating Blades are Dangerous - Protect Children and Prevent Accidents

PROTECT CHILDREN:

- Never assume that children will remain where you last saw them. Children are attracted to mowing activity, stay alert to the presence of children.
- Keep children in the house when you are operating the machine.
- Turn machine off if a child enters the mowing area.
- Use extra care when you come to blind corners, shrubs, trees, or other objects that may block your vision.
- DO NOT let children or an untrained person operate the machine.
- DO NOT carry or let children ride on machine or any attachment. DO NOT tow children in a cart or trailer.

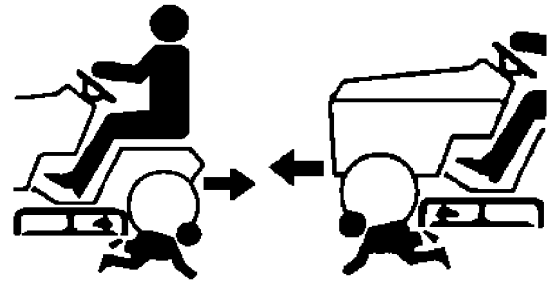

HELP PREVENT SERIOUS OR FATAL ACCIDENTS:

- Be alert at all times, drive forward carefully. People especially children can move quickly into the mowing area before you know it.
- Back carefully. Disengage mower blades and look behind the machine carefully, especially for children, before you back up.
- DO NOT mow in reverse unless it is absolutely necessary.
- Disengage mower blades when you are not mowing.
- DO NOT operate machine if you are under the influence of drugs or alcohol.

OPERATING MACHINE

Avoid Tipping

- DO NOT drive where machine could slip or tip.
- Stay alert for holes and other hidden hazards in the terrain.
- Keep away from drop-offs.
- Slow down before you make a sharp turn or operate on a slope.
- When pulling loads or using heavy equipment, use only approved hitches, limit loads to those you can safely control, and use counterweights or wheel weights when required per this manual or your attachment manual.
- Drive up and down a hill—not across. Be careful when you change direction on a slope.
- DO NOT stop when going up hill or down hill. If machine stops going up hill, DISENGAGE mower blades and back down slowly.
- DO NOT mow wet grass. Reduced traction could cause sliding.
- DO NOT try to stabilize the machine by putting your foot on the ground.

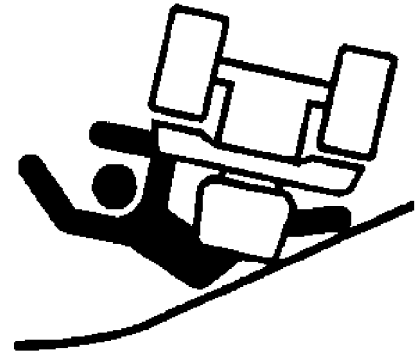

Keep Riders Off

- Only allow the operator on the machine. Keep riders off.
- Riders on the machine or attachment may be struck by foreign objects or thrown off the machine causing serious injury.
- Riders obstruct the operator's view resulting in the machine being operated in an unsafe manner.

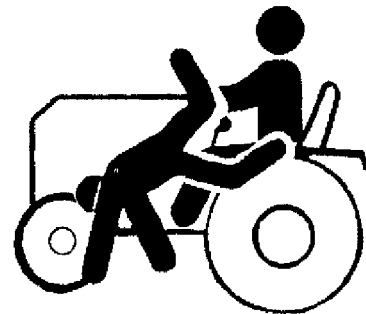

Wear Appropriate Clothing

- Wear close fitting clothing and safety equipment appropriate for the job.
- Loud noise can cause impairment or loss of hearing, wear a suitable protective device such as earplugs.

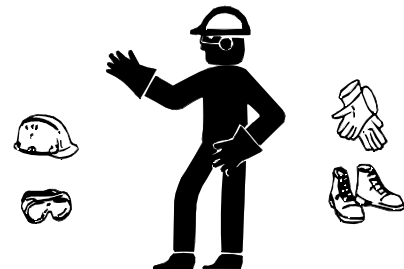

OPERATING MACHINE

Transport Safely

- Use safety lights and devices. Slow moving machines when driven on public roads are hard to see, especially at night. Avoid personal injury or death resulting from a collision with a vehicle.
- Whenever driving on public roads, use flashing warning lights and turn signals according to local regulations. Extra flashing warning lights may need to be installed.

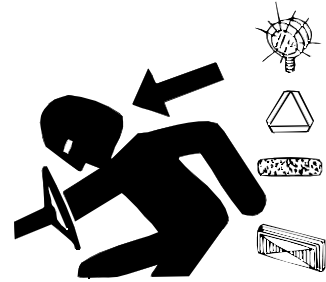

Adjusting Seat

1. Pivot seat forward on its mounting bracket.
2. Loosen front seat knobs (A).
3. Slide forward or rearward on mounting bracket to desired position.
4. Tighten seat knobs.
5. Lower seat.

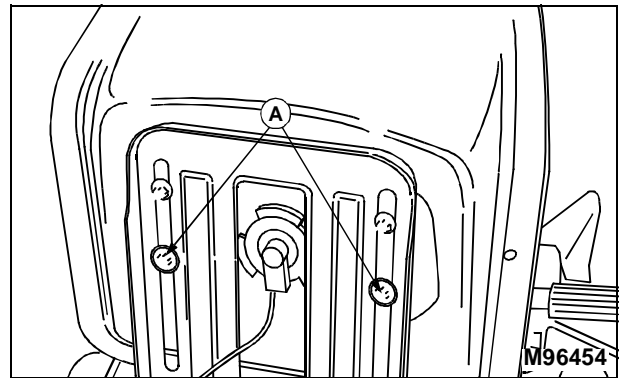

Using the Park Brake

CAUTION: To avoid injury, always **LOCK** park brake before getting off tractor or leaving tractor unattended.

LOCKING PARK BRAKE:

1. Push and hold foot pedal (A) all the way down.
2. Move park brake lever (B) forward, then to the left to lock position.
3. Remove foot from pedal. Pedal should not return to the up position.

UNLOCKING PARK BRAKE

1. Push and hold foot pedal (A) all the way down.
2. Move park brake lever (B) to the right, then to the rear.
3. Remove foot from pedal. Pedal should return to the up position.

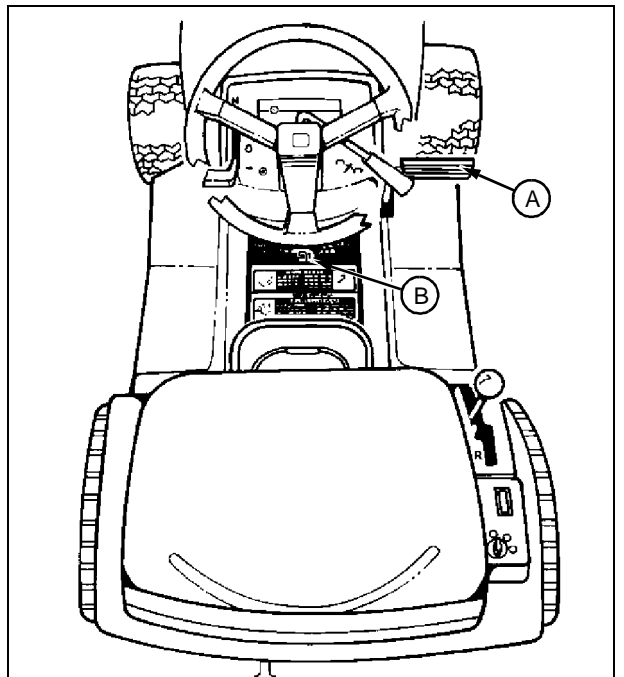

OPERATING MACHINE

Starting Engine



CAUTION: Start engine **ONLY** outdoors or in a well ventilated place. Exhaust fumes are dangerous.

IMPORTANT: Do not operate starter more than 20 seconds at a time, or you may damage it. If engine does not start: Wait two minutes before you try again. See Troubleshooting section.

NOTE: Engine will not start unless: PTO lever is **DISENGAGED**, park brake is **LOCKED** or brake pedal pushed down.

1. Move transmission shift lever (A) to N (NEUTRAL) position.
2. Lock the park brake (B).
3. Pull PTO lever (C) all the way back to the rearward (OFF) position.
4. Place the throttle lever (D) in the FAST (🐾) position and pull the choke knob (E) out.

NOTE: As the engine starts and begins to run smoothly, push the choke knob in until fully seated. Also move throttle lever to the desired engine speed.

5. Turn ignition key (F) to start position to crank the engine. Crank engine until it starts, but no longer than 5 seconds.
6. If engine starts, release key to run position. If engine does not start, release key to run position and wait 10 seconds before cranking the engine again.
7. Let engine run for a couple of minutes to warm-up before operating tractor.

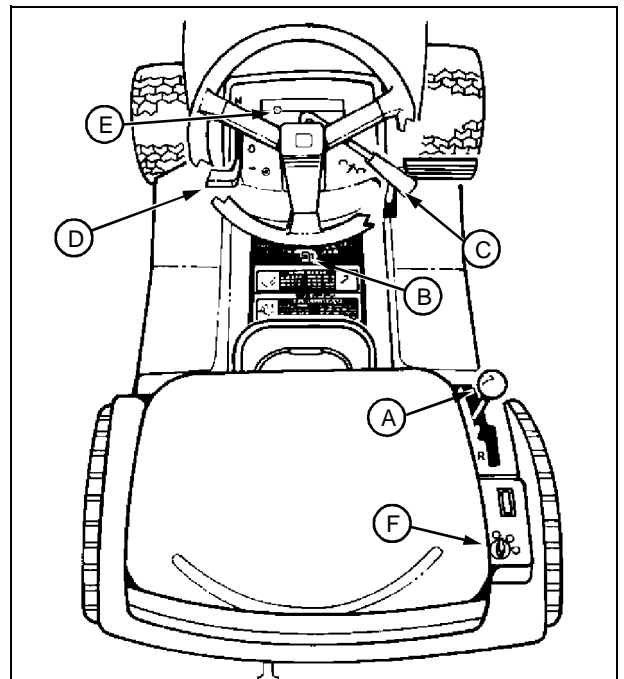

OPERATING MACHINE

Using Throttle Control

Always operate the engine at FULL (👉) THROTTLE.

Operating the engine at less than full throttle reduces the battery charging rate and reduces fan cooling efficiency of the engine.

Full throttle offers the best bagging and mower performance.

Cold Weather Starting Tips

Always use fresh winter grade fuel.

Do not crank engine for more than 30 seconds in any single attempt.

During first minute of operation engine may be operated in partial choke to allow smoother running. As engine warms slowly increase engine speed to the full throttle detent position.

Allow engine to run for a few minutes before using tractor to allow automatic transmission oil to warm. Sluggish transmission response in cold weather indicates that oil has not warmed to allow optimum performance.

Warming and Idling Engine

WARMING ENGINE:

- Run Engine at half speed for 2–3 minutes.

IDLING ENGINE:

- Engine is air-cooled and needs a large volume of air to keep cool. Keep air intake screen (A) on top of engine clean.
- Avoid unnecessary engine idling.

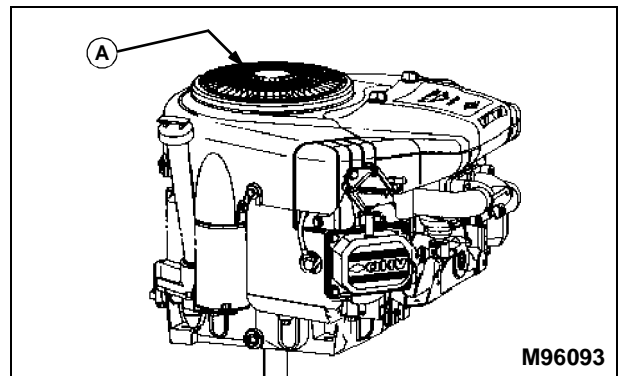

OPERATING MACHINE

Stopping Engine

1. Push down on foot pedal (A).
2. Put gearshift lever (B) in NEUTRAL (N) position.
3. Pull PTO lever (C) all the way back to the rearward (OFF) position.
4. Move throttle lever (D) to SLOW (🐢) position. Let engine run at low throttle a few seconds.
5. Turn key (E) to OFF position.
6. Remove key.
7. LOCK the park brake.

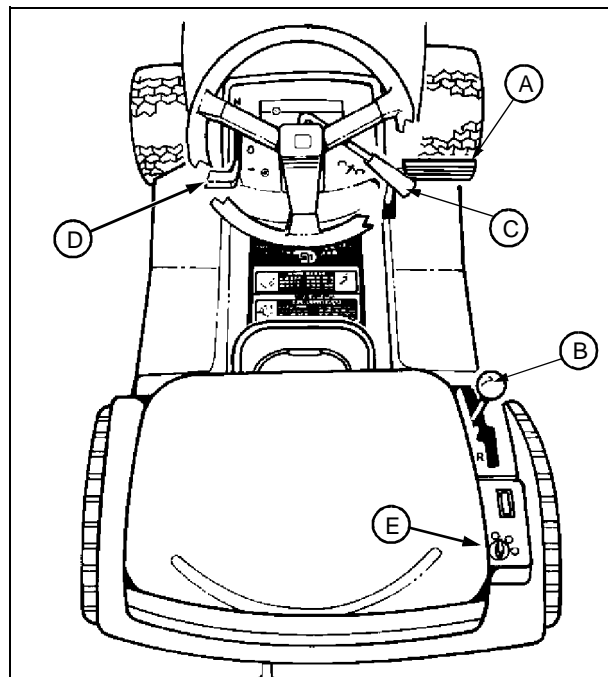

OPERATING MACHINE

Using Travel Controls



CAUTION: TO AVOID INJURY:

- Before moving forward or rearward, make sure area is clear of bystanders, especially children.
- Disengage mower or attachment before backing up.

TO TRAVEL FORWARD:

1. Move transmission shift lever (A) to the right and forward. The speed of the tractor is determined by how far forward the shift lever is moved.

IMPORTANT: To prevent transmission damage, stop tractor movement before changing direction of travel.

TO TRAVEL IN REVERSE:

NOTE: The engine and mower will stop as the drive lever is moved to the R (REVERSE) position with mower engaged.

1. Push foot pedal (B) all the way down to STOP tractor.
2. Pull PTO lever (C) all the way back to the rearward (OFF) position.
3. Look behind the vehicle to be sure there are no bystanders nearby.
4. Move transmission shift lever (A) to the right and rearward to the R (Reverse) position.

FOR EMERGENCY STOPPING:

1. Push down on foot pedal (B). Transmission shift lever (A) will return to NEUTRAL position.

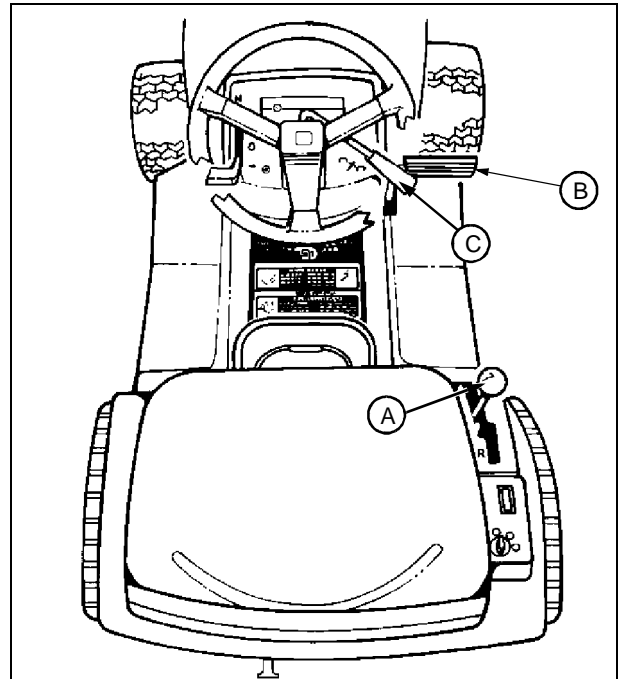



Suggest:

If the above button click is invalid.

Please download this document

first, and then click the above link

to download the complete manual.

Thank you so much for reading

OPERATING MACHINE

Using Reverse Implement Option

CAUTION: TO AVOID INJURY: Before moving forward or rearward, make sure area is clear of bystanders, especially children.

NOTE: Operating the mower while backing up is strongly discouraged. The Reverse Implement Option should be used **ONLY** when operating another attachment or when the operator deems it necessary to reposition the machine with the mower engaged.

1. Stop the machine FORWARD travel with mower engaged.
2. Look behind the vehicle to be sure there are **no bystanders**.
3. Push and hold in the reverse implement switch (A) while moving drive lever to the rear.

NOTE: If the engine and mower stop while repositioning the machine, return mower engagement lever to the OFF position and restart the machine. (See Starting The Engine in this section.) Begin again with Step 2.

4. As the machine begins to move rearward, release the reverse implement switch and reposition the machine.
5. Resume FORWARD travel. The mower should continue operating.
6. Repeat Steps 1 through 5 to reposition the machine again.

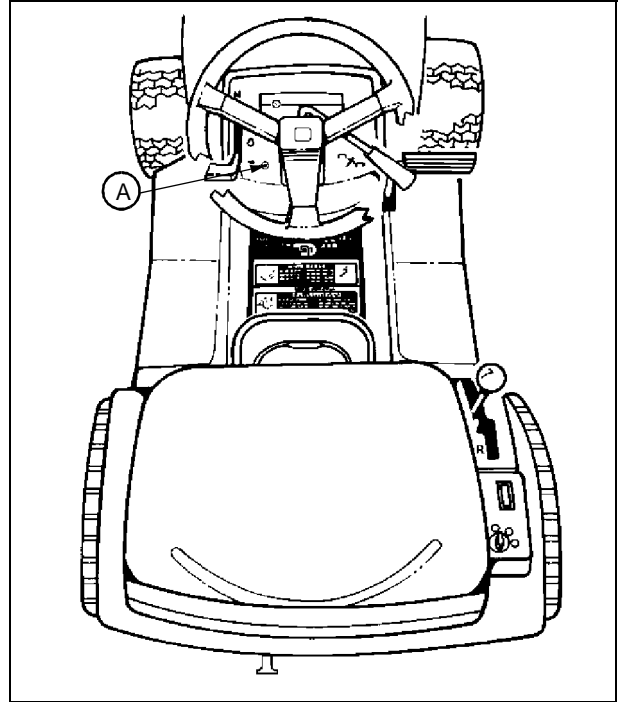

<https://www.ebooklibonline.com>

Hello dear friend!

Thank you very much for reading.

Enter the link into your browser.

The full manual is available for immediate download.

<https://www.ebooklibonline.com>