

REAR BLADES

RB2160

RB2172

RB2184

RB2196

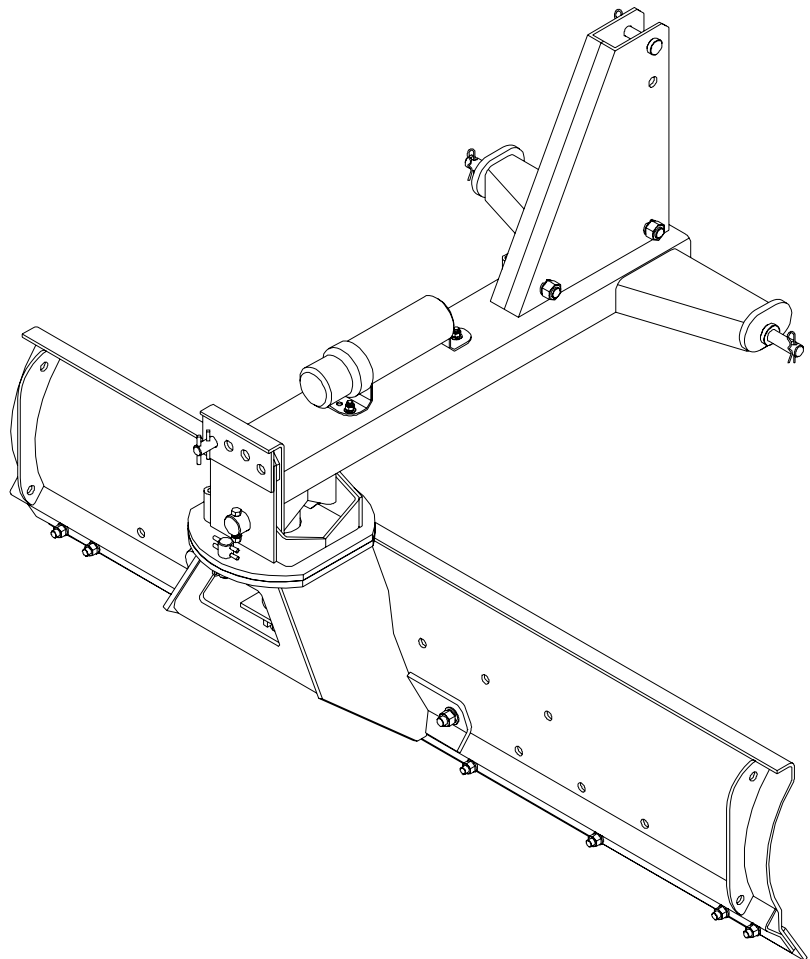

TO THE DEALER:

Assembly and proper installation of this product is the responsibility of the Frontier dealer. Read manual instructions and safety rules. Make sure all items on the Dealer's Pre-delivery and Delivery Check Lists in the Operator's Manual are completed before releasing equipment to the owner.

TO THE OWNER:

Read this manual before operating your Frontier equipment. The information presented will prepare you to do a better and safer job. Keep this manual handy for ready reference. Require all operators to read this manual carefully and become acquainted with all the adjustment and operating procedures before attempting to operate. Replacement manuals can be obtained from your selling dealer.

The equipment you have purchased has been carefully engineered and manufactured to provide dependable and satisfactory use. Like all mechanical products, it will require cleaning and upkeep. Lubricate the unit as specified. Observe all safety information in this manual and safety decals on the equipment.

For service, your authorized Frontier dealer has trained mechanics, genuine Frontier service parts, and the necessary tools and equipment to handle all your needs.

Use only genuine Frontier service parts. Substitute parts will void the warranty and may not meet standards required for safe and satisfactory operation. Record the model number and serial number of your equipment in the spaces provided:

Model: _____ **Date of Purchase:**_____

Serial Number: (see Safety & Instructional Decals section for location)_____

Provide this information to your dealer to obtain correct repair parts.

Throughout this manual, the term **IMPORTANT** is used to indicate that failure to observe can cause damage to equipment. The terms **CAUTION**, **WARNING**, and **DANGER** are used in conjunction with the Safety-alert Symbol, (a triangle with an exclamation mark), to indicate the degree of hazard for items of personal safety.



This Safety-alert Symbol indicates a hazard and means **ATTENTION! BECOME ALERT! YOUR SAFETY IS INVOLVED!**



Indicates an imminently hazardous situation that, if not avoided, will result in death or serious injury.



Indicates a potentially hazardous situation that, if not avoided, could result in death or serious injury, and includes hazards that are exposed when guards are removed.



Indicates a potentially hazardous situation that, if not avoided, may result in minor or moderate injury.

IMPORTANT

Indicates that failure to observe can cause damage to equipment.

NOTE

Indicates helpful information.

TABLE OF CONTENTS

INTRODUCTION.....	ii
GENERAL INFORMATION.....	1
SPECIFICATIONS.....	2
SAFETY RULES.....	3
SAFETY & INSTRUCTIONAL DECALS.....	5
OPERATION.....	7
OWNER SERVICE.....	13
ASSEMBLY.....	15
PARTS INDEX.....	26
BOLT TORQUE CHART.....	31
BOLT SIZE CHART & ABBREVIATIONS.....	32

GENERAL INFORMATION

The purpose of this manual is to assist you in operating and maintaining your rear blade. Read it carefully. It furnishes information and instructions that will help you achieve years of dependable performance. These instructions have been compiled from extensive field experience and engineering data. Some information may be general in nature, due to unknown and varying operating conditions. However, through experience and these instructions, you should be able to develop procedures suitable to your particular situation.

The illustrations and data used in this manual were current at the time of printing. However, due to possible inline production changes, your machine may vary slightly in detail. We reserve the right to redesign and change the machines as may be necessary without notification.

Throughout this manual, references are made to right and left direction. These are determined by standing behind the tractor facing the direction of forward travel.

<https://www.ebooklibonline.com>

Hello dear friend!

Thank you very much for reading.

Enter the link into your browser.

The full manual is available for immediate download.

<https://www.ebooklibonline.com>

RB2160 / RB2172 / RB2184 / RB2196 SPECIFICATIONS

Models	RB2160	RB2172	RB2184	RB2196
Features & Specifications				
Angle, tilt, & offset	Manually adjusted angle, tilt and offset	Manually adjusted angle, tilt and offset	Manually adjusted angle, tilt and offset	Manually adjusted angle, tilt and offset
Hitch compatibility	Cat. 1 iMatch Compatible	Cat. 1 iMatch Compatible	Cat. 1 iMatch Compatible	Cat. 1 iMatch Compatible
Frame	Formed steel channel frame	Formed steel channel frame	Formed steel channel frame	Formed steel channel frame
Cutting edge	½" x 6" reversible	½" x 6" reversible	½" x 6" reversible	½" x 6" reversible
Angle/Pivot	360 Degrees	360 Degrees	360 Degrees	360 Degrees
Angle-Forward	3, up to 53 degrees each side	3, up to 53 degrees each side	3, up to 53 degrees each side	3, up to 53 degrees each side
Angle-Reverse	3, up to 53 degrees each side	3, up to 53 degrees each side	3, up to 53 degrees each side	3, up to 53 degrees each side
Moldboard thickness	1/4"	1/4"	1/4"	1/4"
Moldboard length	60"	72"	84"	96"
Moldboard height	17"	17"	17"	17"
Moldboard type	Progressive-formed	Progressive-formed	Progressive-formed	Progressive-formed
Moldboard upper edge	Full bend	Full bend	Full bend	Full bend
Offset (or swing)	6" or 12" left or right	6" or 12" left or right	6" or 12" left or right	6" or 12" left or right
Tractor max. HP	65HP (2WD) 60HP (4WD)	65HP (2WD) 60HP (4WD)	65HP (2WD) 60HP (4WD)	65HP (2WD) 60HP (4WD)
Tilt	3, up to 22 degrees up and down	3, up to 22 degrees up and down	3, up to 22 degrees up and down	3, up to 22 degrees up and down
Operating weight	392 lbs.	422 lbs.	448 lbs.	476 lbs.

***Tecnomec Agrícola, S.A. de C.V. reserves the right to make any changes deemed necessary to the specifications without prior notice.**



SAFETY RULES

ATTENTION! BECOME ALERT! YOUR SAFETY IS INVOLVED!



Safety is a primary concern in the design and manufacture of our products. Unfortunately, our efforts to provide safe equipment can be wiped out by an operator's single careless act.

In addition to the design and configuration of equipment, hazard control and accident prevention are dependent upon the awareness, concern, judgement, and proper training of personnel involved in the operation, transport, maintenance, and storage of equipment.

It has been said "The best safety device is an informed, careful operator." We ask you to be that kind of operator.

TRAINING

- **Safety instructions are important! Read all attachment and power unit manuals; follow all safety rules and safety decal information. (Replacement manuals are available from your dealer). Failure to follow instructions or safety rules can result in serious injury or death.**
- **If you do not understand any part of this manual and need assistance, see your dealer.**
- **Know your controls and how to stop engine and attachment quickly in an emergency.**
- **Operators must be instructed in and be capable of the safe operation of the equipment, its attachments, and all controls. Do not allow anyone to operate this equipment without proper instructions.**
- **Never allow children or untrained persons to operate equipment.**

PREPARATION

- **Check that all hardware is properly installed. Always tighten to torque chart specifications unless instructed otherwise in this manual.**
- **Always wear relatively tight and belted clothing to avoid entanglement in moving parts. Wear sturdy, rough-soled work shoes and protective equipment for eyes, hair, hands, hearing, and head.**
- **Make sure attachment is properly secured, adjusted, and in good operating condition.**
- **Power unit must be equipped with ROPS or ROPS cab and seat belt. Keep seat belt securely fastened. Falling off power unit can result in death from being run over or crushed. Keep foldable ROPS systems in "locked up" position at all times.**
- **Make sure all safety decals are installed. Replace if damaged. (See Safety & Instructional Decals section for location).**
- **A minimum 20% of tractor and equipment weight must be on the tractor front wheels when attachments are in transport position. Without this weight, tractor could tip over, causing personal injury or death. The weight may be attained with a loader, front wheel weights, ballast in tires or front tractor weights. Weigh the tractor and equipment. Do not estimate.**

OPERATION

- **Do not allow bystanders in the area when operating, attaching, removing, assembling, or servicing equipment.**
- **Do not operate equipment while under the influence of alcohol or drugs.**
- **Operate only in daylight or good artificial light.**
- **Keep hands, feet, hair, and clothing away from equipment while engine is running. Stay clear of all moving parts.**

(Safety Rules continued on next page)



SAFETY RULES

ATTENTION! BECOME ALERT! YOUR SAFETY IS INVOLVED!



(Safety Rules continued from previous page)

- Always comply with all state and local lighting and marking requirements.
- Never allow riders on power unit or attachment.
- Power unit must be equipped with ROPS or ROPS cab and seat belt. Keep seat belt securely fastened. Falling off power unit can result in death from being run over or crushed. Keep foldable ROPS systems in “locked up” position at all times.
- Always sit in power unit seat when operating controls or starting engine. Securely fasten seat belt, place transmission in neutral, engage brake, and ensure all other controls are disengaged before starting power unit engine.
- Look down and to the rear and make sure area is clear before operating in reverse.
- Do not operate on steep slopes.
- Do not stop, start, or change directions suddenly on slopes.
- Use extreme care and reduce ground speed on slopes and rough terrain.
- Watch for hidden hazards on the terrain during operation.
- Stop power unit and equipment immediately upon striking an obstruction. Turn off engine, remove key, inspect, and repair any damage before resuming operation.
- Before changing positions of manual swing, tilt, or angle positions:
 - Park tractor on level ground, apply parking brake, level implement boom, shut off tractor, and remove key.
 - Make manual changes slowly and carefully to prevent hazardous movement of mechanisms.
 - Never stand in positions where you could become entrapped during adjustment changes or if the 3-point hitch suddenly lowers.
- Always secure lock pins with safety pins to prevent lock pins from bumping out of the positioning holes. Failure to do so may result in accidents and/or damage to rear blade.
- Before dismounting power unit or performing any service or maintenance, follow these steps: disengage power to equipment, lower the 3-point hitch and all raised components to the ground, operate valve levers to release any hydraulic pressure, set parking brake, stop engine, remove key, and unfasten seat belt.

- Before working underneath, read manual instructions, securely block up, and check stability. Secure blocking prevents equipment from dropping due to hydraulic leak down, hydraulic system failure, or mechanical component failure.

MAINTENANCE

- Before dismounting power unit or performing any service or maintenance, follow these steps: disengage power to equipment, lower the 3-point hitch and all raised components to the ground, operate valve levers to release any hydraulic pressure, set parking brake, stop engine, remove key, and unfasten seat belt.
- Before performing any service or maintenance, lower attachment to ground, turn off engine, set parking brake, and remove key.
- Before working underneath, read manual instructions, securely block up, and check stability. Secure blocking prevents equipment from dropping due to hydraulic leak down, hydraulic system failure, or mechanical component failure.
- Always wear relatively tight and belted clothing to avoid entanglement in moving parts. Wear sturdy, rough-soled work shoes and protective equipment for eyes, hair, hands, hearing, and head.
- Do not modify or alter or permit anyone else to modify or alter the equipment or any of its components in any way.
- Make sure attachment is properly secured, adjusted, and in good operating condition.
- Never perform service or maintenance with engine running.
- Keep all persons away from operator control area while performing adjustments, service, or maintenance.
- Tighten all bolts, nuts and screws to torque chart specifications. Check that all cotter pins are installed securely to ensure equipment is in a safe condition before putting unit into service.
- Make sure all safety decals are installed. Replace if damaged. (See Safety & Instructional Decals section for location).

STORAGE

- Secure equipment parking stand(s) in park position before detaching.
- Keep children and bystanders away from storage area.



SAFETY & INSTRUCTIONAL DECALS

ATTENTION! BECOME ALERT! YOUR SAFETY IS INVOLVED!

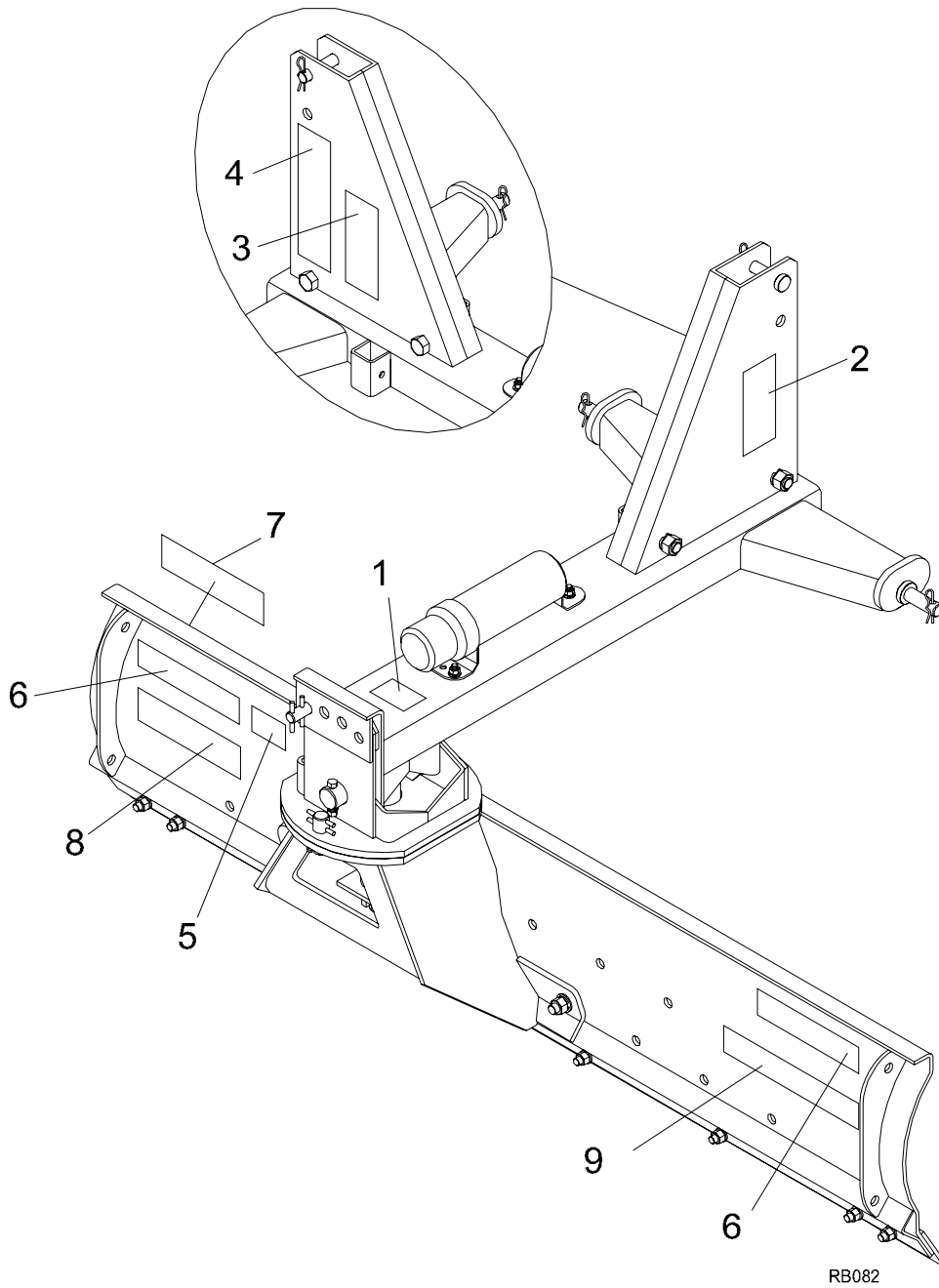

1 - Serial Number Plate (1)

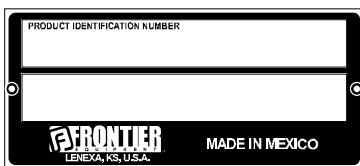



SAFETY & INSTRUCTIONAL DECALS

ATTENTION! BECOME ALERT! YOUR SAFETY IS INVOLVED!

Replace Immediately If Damaged!



2.- 5TM310707100 (1)* (English)
5TM310708100 (1)** (French)

WARNING



CRUSHING AND PINCHING HAZARD

- Be extremely careful handling various parts of the hitching mechanism. They are heavy and hands, fingers, feet, and other body parts could be crushed or pinched between tractor and implement.
- Operate tractor controls from tractor seat only.
- Do not stand between tractor and implement when tractor is in gear.
- Make sure parking brake is engaged before going between tractor and implement.
- Stand clear of machine while in operation or when it is being raised or lowered.

FAILURE TO FOLLOW THESE INSTRUCTIONS COULD RESULT IN SERIOUS INJURY OR DEATH.

1002941

3.- 5TM310707200 (1)* (English)
5TM310708200 (1)** (French)

CAUTION

TO AVOID SERIOUS INJURY:

- Read Operator's Manual before operating, servicing, or repairing equipment. Follow all safety rules and instructions. (Manuals are available from your selling dealer.)
- Never allow riders.
- Keep bystanders away from equipment during operation.
- Operate from tractor seat only.
- Keep all shields in place and in good condition.
- Lower equipment to ground, stop engine, remove key, and set brake before dismounting tractor.
- Never allow children or untrained persons to operate equipment.

4310-7072-00

4.- 5TM310707300 (1)* (English)
5TM310708300 (1)** (French)

WARNING

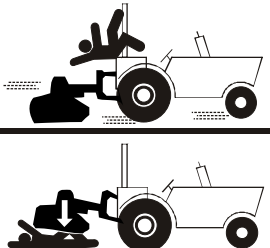

FALLING OFF CAN RESULT IN BEING RUN OVER

- Tractor must be equipped with ROPS (or ROPS CAB) and seat belt. Keep foldable ROPS systems in "locked up" position at all times.
- Buckle Up! Keep seat belt securely fastened.
- Allow no riders.

RAISED IMPLEMENT CAN DROP AND CRUSH.

- Never go underneath raised implement which can drop from equipment or tractor 3-point hitch hydraulic leak down, hydraulic system failures, movement of control levers, or mechanical linkage failures.
- Service work does not require going underneath implement. Read manual instructions.

FALLING OFF OR GOING UNDERNEATH IMPLEMENT CAN RESULT IN SERIOUS INJURY OR DEATH.

55121-C

5.- 5TM310707400 (1)* (English)
5TM310708400 (1)** (French)

WARNING

Unit must not extend more than 4 feet left of center of the tractor when driving on public roads.

- 6.- 5TM310602001 Red Reflector 2" x 9" (2)*
- 7.- 5TM310602002 Yellow Reflector 2" x 9" (1)*
- 8.- 5TM310110203 Frontier decal (1)
- 9.- Model decal (1)

*Included in Safety Decal Kit 5TMC6010015K (English)
**Included in Safety Decal Kit 5TMC6010019K (French)

BE CAREFUL!

Use a clean, damp cloth to clean safety decals.

Avoid spraying too close to decals when using a pressure washer; high-pressure water can enter through very small scratches or under edges of decals causing them to peel or come off.

Replacement safety decals can be ordered free from your dealer.

OPERATION

Safety is a primary concern in the design and manufacture of our products. Unfortunately, our efforts to provide safe equipment can be wiped out by an operator's single careless act.

In addition to the design and configuration of equipment, hazard control and accident prevention are dependent upon the awareness, concern, judgement, and proper training of personnel involved in the operation, transport, maintenance, and storage of equipment.

It has been said "The best safety device is an informed, careful operator." We ask you to be that kind of operator.

WARNING

- Never allow children or untrained persons to operate equipment.
- Do not allow bystanders in the area when operating, attaching, removing, assembling, or servicing equipment.
- Before working underneath, read manual instructions, securely block up, and check stability. Secure blocking prevents equipment from dropping due to hydraulic leak down, hydraulic system failure, or mechanical component failure.
- Never allow riders on power unit or attachment.
- Keep all persons away from operator control area while performing adjustments, service, or maintenance.

WARNING

- A minimum 20% of tractor and equipment weight must be on the tractor front wheels when attachments are in transport position. Without this weight, tractor could tip over, causing personal injury or death. The weight may be attained with a loader, front wheel weights, ballast in tires, or front tractor weights. Weigh the tractor and equipment. Do not estimate.

CAUTION

- Always wear relatively tight and belted clothing to avoid entanglement in moving parts. Wear sturdy, rough-soled work shoes and protective equipment for eyes, hair, hands, hearing, and head.

Operation *Cont'd*

MOUNT REAR BLADE TO TRACTOR

IMPORTANT

■ The rear blade should be mounted on tractors with a maximum power rating of 65 hp (48 kW). For 4WD tractors, the maximum power rating is 60 hp (45 kW).

The rear blade is a 3-point Category 1 implement. It will attach to ASAE standard Category 1 quick-attaching coupler.

Place the tractor rockshift control in "position control" (non-floating) for attaching and detaching the rear mounted blade. "Draft control" or "position control" can be used while operating.

Back the tractor until the ends of the lift arms can be attached to the lift points on the implement. Secure the lift arms to the mast.

Attach the center link to the top of the mast and adjust so that the rear blade will be level in the operating position.

CATEGORY 1

1. Place the lift arms around the lower hitch pins (5). Secure with klik pin (17).
2. Connect the tractor top link to upper hitch support hole of the 3-point hitch mast (25) using the upper hitch pin category 1 (6). Secure with the 1/8 safety pin (24).
3. Level the main frame by adjusting lift and top links.
4. Position sway blocks to eliminate side sway or install sway braces if required.

CATEGORY 1 QUICK-HITCH

1. Insert 1 7/16 O.D. lower hitch pin bushings* around the lower hitch pins (5). Secure with klik pins (17).
2. Place upper hitch pin category 1 (6) and 1 1/4 O.D. upper hitch pin bushing* category 1 in the lower hitch support hole of the 3-point hitch mast (25) and secure with the 1/8 safety pin (24).
3. Back up tractor with 3 quick-hitch attachment into 3-point hitch mast (25) making sure pins are aligned to the center and the outside lower hitch supports.
4. Lift tractor lift arms.
5. Level the main frame by adjusting lift and top links.
6. Position sway blocks to eliminate side sway or install sway braces if required.

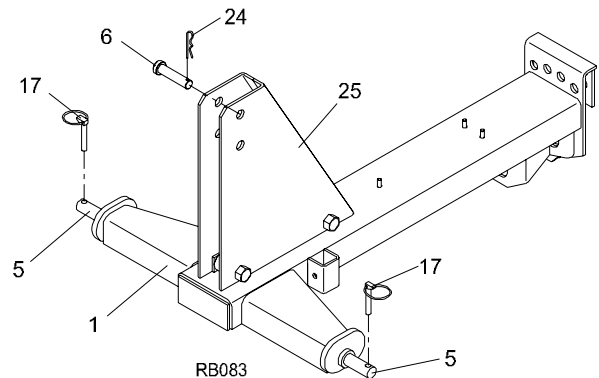

Figure 1. 3-point Hitch Connection

***NOTE:** The upper and lower hitch pin bushings are not included with rear blade.

NOTE: The drawbar may have to be removed on some tractors. Make sure rear blade is at least six inches from tractor tires, throughout operating range of 3-point hitch.



Suggest:

If the above button click is invalid.

Please download this document

first, and then click the above link

to download the complete manual.

Thank you so much for reading

Operation *Cont'd*

⚠ CAUTION

- Before changing positions of manual swing, tilt, or angle positions:
 - Park tractor on level ground, apply parking brake, level implement boom, shut off tractor, and remove key.
 - Make manual changes slowly and carefully to prevent hazardous movement of mechanisms.
 - Never stand in positions where you could become entrapped during adjustment changes or if the 3-point hitch suddenly lowers.

⚠ CAUTION

- Always secure lock pins with safety pins to prevent lock pins from bumping out of the positioning holes. Failure to do so may result in accidents and/or damage to rear blade.

Angle Adjustment

Mechanical Adjustment

Insert the turn table pin (7) using the various hole combinations between the offset plate assembly and the turn table holes to achieve angle positions up to 53 degrees each side. Secure turn table pin (7) with safety pin (24).

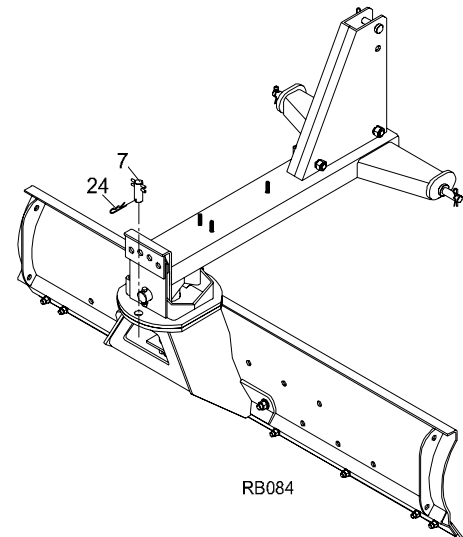

Figure 2. Turn Table Pin

<https://www.ebooklibonline.com>

Hello dear friend!

Thank you very much for reading.

Enter the link into your browser.

The full manual is available for immediate download.

<https://www.ebooklibonline.com>