

OPERATOR'S AND PARTS MANUAL

POWER RAKES

PR1184



FRONTIER
EQUIPMENT

TABLE OF CONTENTS

PREFACE	2
SAFETY PRECAUTIONS	
Safety Statements.....	3
General Safety Precautions	3-5
Equipment Safety Precautions.....	5-7
SAFETY DECALS	8-9
SET-UP	10-13
OPERATIONAL PROCEDURE	14-21
MAINTENANCE	22-27
TROUBLESHOOTING	28
SPECIFICATIONS	
Attachment Specifications.....	29
Bolt Torque specifications	30
ASSEMBLY AND PARTS IDENTIFICATION	32-61

PREFACE

GENERAL INFORMATION

The purpose of this manual is to assist you in operating and maintaining your attachment. Read it carefully. It furnishes information and instructions that will help you achieve years of dependable performance.

These instructions have been compiled from field experience and engineering data. Some information may be general in nature, due to unknown and varying operating conditions. However, through experience and these instructions, you should be able to develop procedures suitable to your particular situation.

The illustrations and data used in this manual were current at the time of printing. However, due to possible in line production changes, your machine may vary slightly in detail. We reserve the right to redesign and change the machines as may be necessary without notification.

Throughout this manual, references are made to right and left direction. These are determined by standing behind the tractor facing the direction of forward travel.



WARNING!  Never let anyone operate this unit without reading the "Safety Precautions" and "Operations" sections of this manual. Always choose hard, level ground to park the unit on and set the brake so the unit cannot roll.

BEFORE OPERATION

The primary responsibility for safety with this equipment falls to the operator. Make sure the equipment is operated only by trained individuals that have read and understand this manual. If there is any portion of this manual or function you do not understand, contact your local Frontier Dealer.

SERVICE

When servicing your product, remember to use only manufacturer replacement parts. Substitute parts may not meet the standards required for safe, dependable operation.

To facilitate parts ordering, record the model and serial number of your unit in the space provided on this page. This information may be obtained from the identification plate located on the product.

Any questions related to this attachment should be directed to your local Frontier dealer.

MODEL: _____ **DATE:** _____

SERIAL NUMBER: _____ (See parts section for location.)

<https://www.ebooklibonline.com>

Hello dear friend!

Thank you very much for reading.

Enter the link into your browser.

The full manual is available for immediate download.

<https://www.ebooklibonline.com>

SAFETY STATEMENTS

 **DANGER** This statement is used where serious injury or death will result if the instructions are not followed properly.

 **WARNING** This statement is used where serious injury or death could result if the instructions are not followed properly.

 **CAUTION** This statement is used where minor injury could result if the instructions are not followed properly.

NOTICE This statement is used where equipment or property damage could result if the instructions are not followed properly.



This symbol by itself or used with a safety signal word throughout this manual is used to call your attention to instructions involving your personal safety or the safety of others. Failure to follow these instructions can result in injury or death.

GENERAL SAFETY PRECAUTIONS

 **WARNING READ MANUAL PRIOR TO INSTALL**
Improper installation, operation, or maintenance of this equipment could result in serious injury or death. Operators and maintenance personnel should read this manual as well as all manuals related to this equipment and the prime mover thoroughly before beginning installation, operation, or maintenance.
FOLLOW ALL SAFETY INSTRUCTIONS IN THIS MANUAL AND THE PRIME MOVERS MANUAL.

 **WARNING READ AND UNDERSTAND ALL SAFETY STATEMENTS**
Read all safety decals and safety statements in all manuals prior to operating or working on this equipment. Know and obey all OSHA regulations, local laws and other professional guidelines for your operation. Know and follow good work practices when assembling, maintaining, repairing, mounting, removing or operating this equipment.



KNOW YOUR EQUIPMENT

Know your equipment's capabilities, dimensions and operations before operating. Visually inspect your equipment before you start, and never operate equipment that is not in proper working order with all safety devices intact. Check all hardware to assure it is tight. Make certain that all locking pins, latches, and connection devices are properly installed and secured. Remove and replace any damaged, fatigued or excessively worn parts. Make certain all safety decals are in place and are legible. Keep decals clean, and replace them if they become worn and hard to read.

⚠️ WARNING PROTECT AGAINST FLYING DEBRIS

Always wear proper safety glasses, goggles or a face shield when driving pins in or out or when any operation causes dust, flying debris, or any other hazardous material.

⚠️ WARNING LOWER OR SUPPORT RAISED EQUIPMENT

Do not work under raised 3 point lift arms without supporting them. Do not use support material made of concrete blocks, logs, buckets, barrels or any other material that could suddenly collapse or shift positions. Make sure support material is solid, not decayed, warped, twisted, or tapered. Lower lift arms to ground level or onto blocks. Lower lift arms and attachments to the ground before leaving the cab or operator's station.

⚠️ WARNING USE CARE WITH HYDRAULIC FLUID PRESSURE

Hydraulic fluid pressure can penetrate the skin and cause serious injury or death. Hydraulic leaks under pressure may not be visible. Before connecting or disconnecting hydraulic hoses, read your prime movers operator's manual for detailed instructions on connecting and disconnecting hydraulic hoses or fittings.

- Keep unprotected body parts, such as face, eyes and arms as far away as possible from a suspected leak. Flesh injected with hydraulic fluid may develop gangrene or other permanent disabilities.
- If injured by injected fluid, see a doctor at once. If your doctor is not familiar with this type of injury, ask him to research immediately to determine proper treatment.
- Wear safety glasses, protective clothing, and use a sound piece of cardboard or wood when searching for hydraulic leaks. **DO NOT USE YOUR HANDS! SEE ILLUSTRATION.**

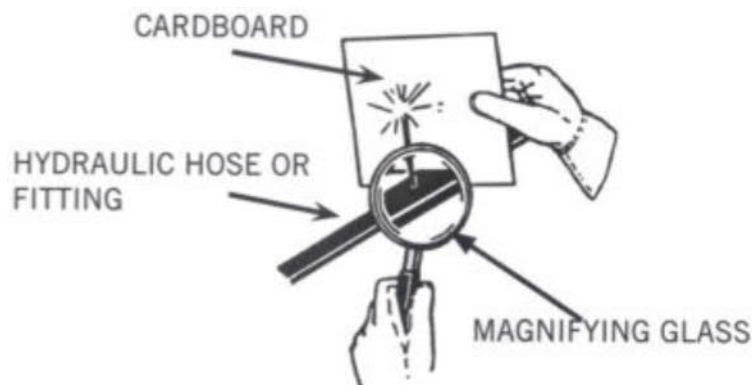

⚠️ WARNING DO NOT MODIFY MACHINE OR ATTACHMENTS

Modifications may weaken the integrity of the attachment and may impair the function, safety, life and performance of the attachment. When making repairs, use only the manufacturer's genuine parts, following authorized instructions. Other parts may be substandard in fit and quality. Never modify any ROPS (Roll Over Protection System) equipment or device. Any modifications must be authorized in writing by the manufacturer.

WARNING SAFELY OPERATE EQUIPMENT

Do not operate equipment until you are completely trained by a qualified operator in how to use the controls, know its capabilities, dimensions, and all safety requirements. See your prime movers manual for these instructions.

- Keep all step plates, grab bars, pedals, and controls free of dirt, grease, debris, and oil.
- Never allow anyone to be around the equipment when it is operating or being serviced.
- Do not allow riders on the attachment or the prime mover.
- Do not operate the equipment from anywhere other than the correct operators position.
- Never leave equipment unattended with the engine running or with this attachment in a raised position.
- Do not alter or remove any safety feature from the prime mover or this attachment.
- Know your work site safety rules as well as traffic rules and flow. When in doubt on any safety issue, contact your supervisor or safety coordinator for an explanation.

WARNING SAFELY MAINTAIN AND REPAIR EQUIPMENT

- Do not wear loose clothing, or any accessories that can catch in moving parts. If you have long hair, cover or secure it so that it does not become entangled in the equipment.
- Work on a level surface in a well lit area.
- Use properly grounded electrical outlets and tools.
- Use the correct tool for the job at hand. Make sure they are in good condition for the task required.
- Wear the protective equipment specified by the tool manufacturer.

EQUIPMENT SAFETY PRECAUTIONS

 **WARNING** Safety is a primary concern in the design and manufacture of our products. Unfortunately, our efforts to provide safe equipment can be wiped out by a single careless act of an operator. In addition to the design and configuration of equipment, hazard control and accident prevention are dependent upon the awareness, concern, prudence and proper training of personnel involved in the operation, transport, maintenance and storage of equipment. The designed and tested safety of this equipment depends on it being operated within the limitations as explained in this manual.

WARNING INITIAL SET-UP AND SYSTEMS CHECK

- Always check with your prime mover manual or dealer for counter weight ballast that may be required for machine stability.
- Air in hydraulic systems can cause erratic operation and allows loads or equipment components to drop unexpectedly.

- Before operating equipment purge any air in the system by engaging all hydraulic functions.
- Check that all control lever positions function as instructed in the Operator's Manual. Do not operate until control lever and equipment movements are correct.
- Make sure all hydraulic hoses, fittings and valves are in good condition and not leaking before starting power unit. Check and route hoses carefully to prevent damage.
- Hoses must not be twisted, bent sharply, kinked, frayed, pinched, or come into contact with any moving parts.
- Operate moveable components through full operational range to check clearances. Replace damaged hoses immediately.
- Ensure implement is properly attached, adjusted and in good condition.
- Tractor must be equipped with ROPS and seat belt/operator restraint.
- Keep seat belt/operator restraint securely fastened/engaged. Falling off tractor can result in death from being run over or crushed. Keep ROPS systems in place at all times.



WARNING SAFELY OPERATE EQUIPMENT

Improper operation can cause the machine to tip or roll over and cause injury or death.

- Keep tractor lift arms and attachment as low as possible.
- Turn on level ground.
- Go up and down slopes, not across them.
- Keep the heavy end of the machine uphill.
- Only engage power when equipment is at ground level. Always disengage power when equipment is raised off the ground.
- Do not disconnect hydraulic lines until all system pressure is relieved.
- Never go underneath equipment lowered to the ground or raised. Hydraulic system leak down, hydraulic system failures, mechanical failures or movement of control levers can cause equipment to drop or rotate unexpectedly and cause severe injury or death.
- Never direct discharge toward people, animals or property.
- Do not operate equipment while under the influence of alcohol or drugs.
- Operate only in the daylight or good artificial lighting.
- Always comply with all state and local lighting and marking requirements.
- Ensure equipment is properly attached, adjusted and in good operating condition.
- Before starting tractor, check all equipment driveline guards for damage and make sure they rotate freely on all drivelines. Replace any damaged guards. If guards do not rotate freely on drivelines, repair and replace bearings before operating.
- Make sure driveline is correct length to prevent bottoming out or pulling apart during the full lift range of the hitch.
- Make sure spring-activated locking pin or collar slides freely and is seated firmly in tractor PTO splined groove.

- A minimum 20% of tractor and equipment weight must be on tractor front wheels with attachments in “transport” position. Without this weight, tractor could tip over causing personal injury or death. The weight may be attained with a loader, front wheel weights, ballast in tires, or front tractor weights. When attaining wheels, you must not exceed the Roll Over Protection Structure (ROPS) weight certification. Weigh the tractor and equipment. Do not estimate.
- Ensure shields and guards are properly installed and in good condition. Replace if damaged.



WARNING WATCH FOR OPERATING HAZARDS

- Look down and to the rear and make sure area is clear before operating in reverse.
- Watch for hidden hazards on the terrain during operation.
- Use extreme care when working close to fences, ditches, other obstructions, or on hillsides.
- Reduce ground speed on slopes and rough terrain.
- Do not operate on steep slopes.
- Do not stop, start or change directions suddenly on slopes. Stop tractor and implement immediately upon striking an obstruction. Dismount tractor using proper procedure. Inspect and repair any damage before resuming operation.



WARNING MAINTENANCE SAFETY

- Your dealer can supply original equipment hydraulic accessories and repair parts. Substitute parts may not meet original equipment specifications and may be dangerous.
- Avoid electrical system hazards. Never work on the electrical system unless you are qualified and thoroughly familiar with system details and the special handling requirements.
- Disconnect battery before working on electrical system. Remove “ground” cable first. When reconnecting battery, connect “ground” cable last.
- Never perform service or maintenance with engine running.
- Tighten all bolts, nuts and screws, and check that all cotter pins are installed securely to ensure equipment is in a safe condition before operating.

SAFETY DECALS

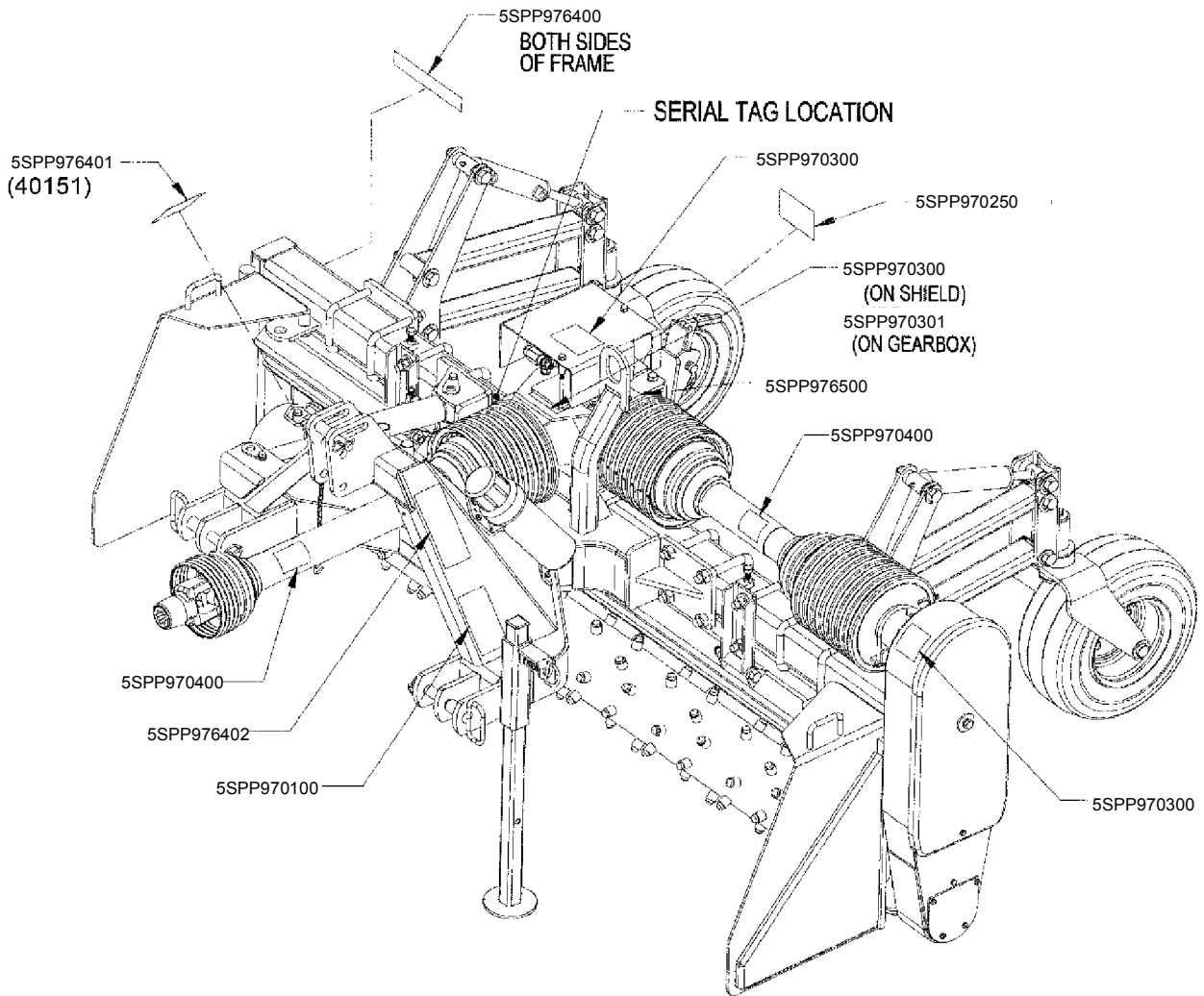

SAFETY DECALS

⚠ DANGER



- Stay at least 10 feet (3m) away from operating equipment.
- Flying objects and rotating parts can cause injury or death.
- Stop engine before cleaning or servicing.
- Keep all guards in place.

P970250

5SPP970250

⚠ DANGER



**ROTATING DRIVELINE CONTACT CAN CAUSE DEATH
KEEP AWAY!**

DO NOT OPERATE WITHOUT -

- ALL DRIVELINE GUARDS, TRACTOR AND EQUIPMENT SHIELDS IN PLACE
- DRIVELINES SECURELY ATTACHED AT BOTH ENDS
- DRIVELINE GUARDS THAT TURN FREELY ON DRIVELINE

5SPP970400

⚠ DANGER



ROTATING PART HAZARD

- CLEAR HANDS, FEET AND CLOTHING AWAY FROM MOVING PARTS
- CLOSE AND SECURE ALL SHIELDS BEFORE OPERATING

FAILURE TO DO SO COULD RESULT IN SERIOUS INJURY OR DEATH

5SPP970301

⚠ DANGER



ROTATING PART HAZARD

- KEEP HANDS, FEET AND CLOTHING AWAY FROM MOVING PARTS
- CLOSE AND SECURE ALL SHIELDS BEFORE OPERATING

FAILURE TO DO SO COULD RESULT IN SERIOUS INJURY OR DEATH

5SPP970300

⚠ WARNING

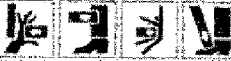

CRUSHING AND PINCHING HAZARD

- Be extremely careful handling various parts of the hitching mechanism. They are heavy and hands, fingers, feet, and other body parts could be crushed or pinched between tractor and implement.
- Operate tractor controls from tractor seat only.
- Do not stand between tractor and implement when tractor is in gear.
- Make sure parking brake is engaged before going between tractor and implement.
- Stand clear of machine while in operation or when it is being raised or lowered.

FAILURE TO FOLLOW THESE INSTRUCTIONS COULD RESULT IN SERIOUS INJURY OR DEATH

5SPP976402

⚠ WARNING



BEFORE ATTACHING, CHECK TRACTOR'S 3PT LIFT CAPACITY TO ENSURE ITS ABILITY TO SAFELY HANDLE THE WEIGHT.

MAX PTO SPEED IS 540 RPM'S

DO NOT OPERATE WITHOUT GUARDS/SHIELDS IN PLACE AND IN GOOD WORKING ORDER.

STOP ALL MOVING PARTS INCLUDING TRACTOR ENGINE BEFORE CLEANING, UNPLUGGING, ADJUSTING, AND/OR PERFORMING MAINTENANCE.

KEEP BYSTANDERS 10 FEET FROM POWER RAKE WHEN IN OPERATION

5SPP970100

⚠ WARNING



HIGH-PRESSURE FLUID HAZARD

To prevent serious injury or death:

- Relieve pressure on system before repairing or adjusting or disconnecting.
- Wear proper hand and eye protection when searching for leaks. Use wood or cardboard instead of hands.
- Keep all components in good repair.

5SPP976401



P973600

5SPP976500

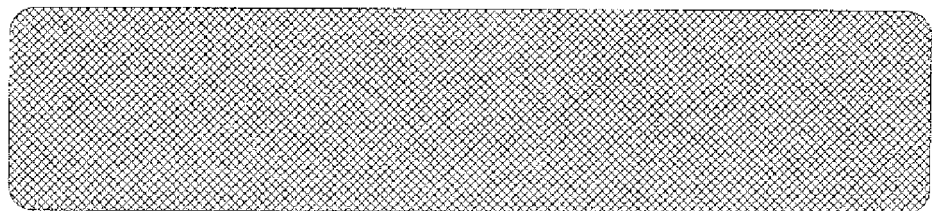

5SPP976400

SET-UP

SET-UP INSTRUCTIONS

The power rake is shipped partially assembled. Assembly will be easier if components are aligned and loosely assembled before tightening hardware. Recommended torque values for hardware are located on page 30.

Select a suitable working area. Refer to illustrations, accompanying text, parts lists, and exploded view drawings.

For reference, front, back, left and right directions are determined by sitting in the tractor's operator's seat.

It is advisable to have a mechanical lifting device to facilitate uncrating.

UNPACKING CRATE

Be careful of nails in boards when uncrating.

1. Remove top, sides, and ends of crate.
2. Remove mast frame.
3. Remove gauge wheel assemblies.
4. Remove right and left endplates.
5. Remove rake assembly from crate.
6. Remove loose nails from boards and dispose of crate according to local codes.

STANDARD MODEL ASSEMBLY PROCEDURE (See Pages 12 & 34)

Tools Required

15/16", 1-7/16", 1-1/2" combination wrenches

1. Stand rake frame upright and position one endplate on each side of frame to stabilize the rake.
2. Attach the two gauge wheel assemblies to main frame using two 5/8" u-bolts and locking nuts.
3. Slide mast frame between yoke plate on frame, making sure pivot bushing is in place.
4. Install 1" X 6-1/2" bolt with washer on head end (bolt installed from under side of mast).
5. Extend jackstand to help stabilize rake.
6. Slide front PTO over gearbox shaft until hardware mounting holes are aligned with shaft groove. Install supplied 5/8" X 3" GR8 bolts and lock nuts and then tighten.
7. Attach angle cylinder to mast frame.

SET-UP

FLEX MODEL ASSEMBLY PROCEDURE (See Pages 12 & 36)

Tools Required

15/16", 1-1/16", 1-7/16", 1-1/2" combination wrenches

1. Stand rake frame upright and position one endplate on each side of frame to stabilize the rake.
2. Attach the two gauge wheel assemblies to main frame using two 5/8" U-bolts and locking nuts.
3. Slide mast frame between yoke plate on frame, making sure pivot bushing is in place.
4. Install 1" X 6-1/2" bolt with washer on head end (bolt installed from under side of mast).
5. Extend jackstand to help stabilize rake.
6. Slide front PTO over gearbox shaft until hardware mounting holes are aligned with shaft groove. Install supplied 5/8" X 3" GR8 bolts and lock nuts and then tighten.
7. Attach angle cylinder to mast frame.
8. Install hydraulic cylinders into flex caster arm assemblies using 3/4" bolts, spacers, and lock nuts. Do not over tighten.

SET-UP

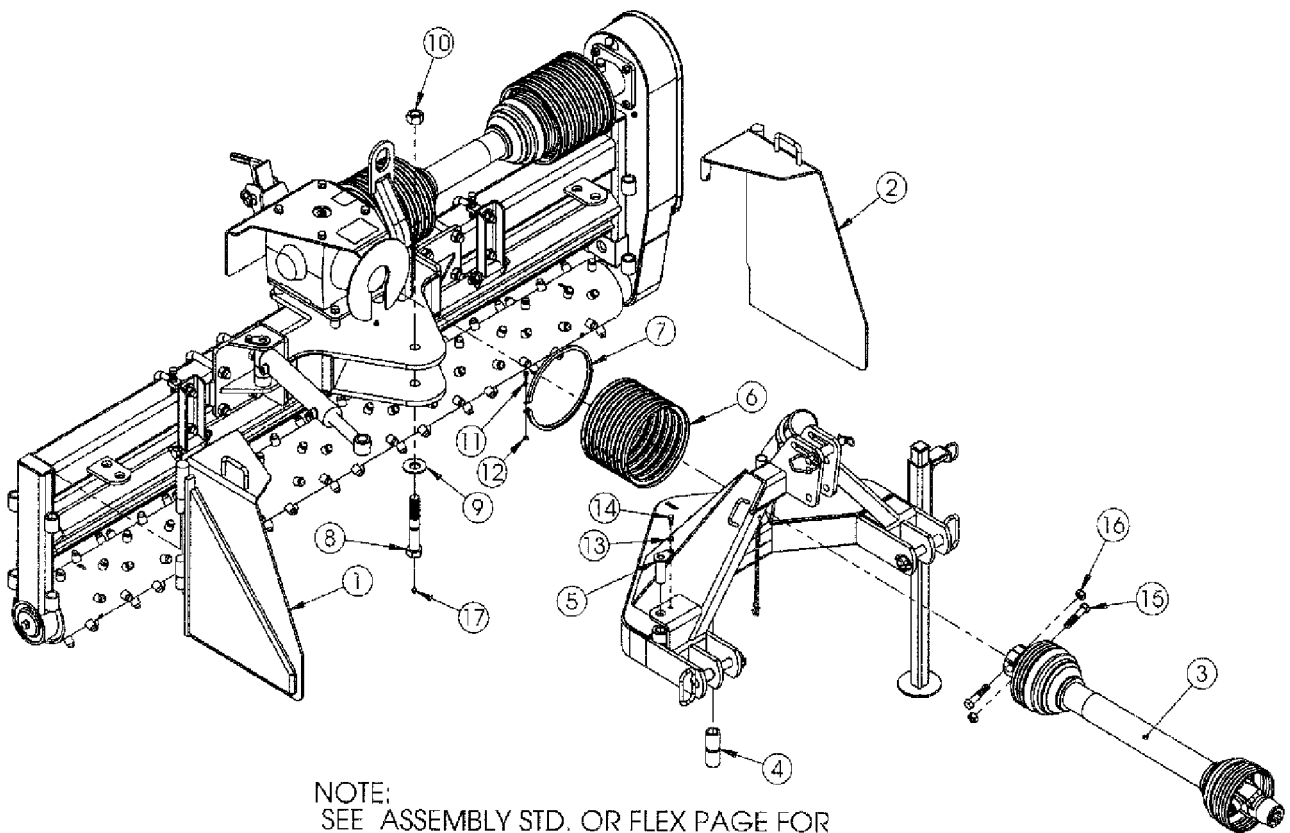

NOTE:
SEE ASSEMBLY STD. OR FLEX PAGE FOR
CASTER WHEEL ASSEMBLY. THIS WILL
DEPEND UPON MACHINE PURCHASED.

SET-UP

<u>ITEM</u>	<u>QTY</u>	<u>PART NO.</u>	<u>DESCRIPTION</u>
1	1	5SPM27128	Right Endplate W/Pin
2	1	5SPM27129	Left Endplate W/Pin
3	1	5SPP403500	Main PTO
4	1	5SPM18044	Pivot Bolt
5	1	5SPM27106	3" Lock Pin
6	1	5SPM27107	Drive Shield
7	1	5SPM6581	Shield Clamp
8	1	5SPM27103	1" X 6-1/2" Pivot Bolt
9	1	5SPP850116	1" Zinc Flat Washer
10	1	5SPP156401	1"-14 Top Lock Nut
11	1	5SPP115406	1/4"-20 X 1-1/2" Fillister Head Screw
12	1	5MP1629	1/4" UNC Nylock Nut
13	1	5MP1503	3/8" Lock Washer
14	1	5SPP100603	3/8"-16 X 3/4" Hex Bolt
15	2	5SPP102011	5/8"-11 X 2-3/4" Hex Bolt GR8
16	2	5SPP157500	5/8"-11 Top Lock Nut
17	1	5MP6616	1/4"-28 UNF Grease Fitting

OPERATIONAL PROCEDURE

NOTICE The Frontier Power Box Rake is designed for removing rock and small debris and for thatching. This manual contains information for all tractor mounted Frontier Power Box Rakes. Refer to the information in this manual for specifications, parts, assemblies and adjustments per your specific model.

ATTACHING POWER RAKE TO TRACTOR

Move tractor into position in front of the power rake. Move back slowly and carefully, not allowing anyone to be between the tractor and the rake. Turn off tractor engine. Attach the two lower arms of the 3-point hitch with the two hitch-pin assemblies.

Attach the tractor center link to the upper hitch point of the power rake. Use either the “lock-out” setting or the “float” feature depending on your application.

Attach the front PTO from the power rake to the tractor. Slide the front section of the PTO into the back section and attach to the PTO shaft at the rear of the tractor.

Reattach driveline storage chain in its original position so that it will not contact PTO driveline.



- **If the PTO is too long, severe PTO and gearbox damage is possible when hooking up the PTO from the power rake to the tractor. The front PTO is long enough to fit a variety of tractors. It is possible that the front PTO may be too long for your application. If this is the case, see your dealer for replacement driveline or for factory approved modification to existing driveline.**

The PTO, when attached to the tractor and gearbox, must not extend so there is less than five inches of overlap within the PTO.

Attach the two hydraulic lines on the rake to the two female hydraulic couplers on the tractor. The hydraulic hose ends on the power rake are ISO male couplers, which are compatible with newer tractors.

Raise jack stand and secure in operating position.

For flex models, mount the control box in a convenient, easy-to-reach location. The control box is magnetic and will attach to any flat steel surface. Connect the power cord to the cable coming from the switch. Be careful when routing the cable that sharp edges or moving parts will not damage the cable.



- **Always clean connector ends prior to attaching. Dirt could contaminate hydraulic fluid and damage the hydraulic system.**

POWER RAKE FUNCTION

The tractor PTO drives the roller, which digs into the ground, cultivating and pulling up rocks, roots, and debris.

OPERATIONAL PROCEDURE

The clean soil goes between the roller and barrier, while the rocks, roots, and debris work to the side in a windrow.

With the endplates mounted in the working position and the rake straight (endplates parallel with tractor tires), material can be moved along, filling in the low spots.

Maximum safe PTO operating speed is 540 RPM.

Before using your new Frontier Power Rake, the slip clutch assembly must be RUN-IN. See CLUTCH in the maintenance section, page 24, for the RUN-IN procedure. After you have completed the RUN-IN of the clutch, return to the operating instructions and proceed with start-up. Failure to run the clutch in could result in pre-mature driveline failure and warranty will be voided.

Start tractor engine.

Lower power rake slowly to the ground.

Engage tractor PTO.

Increase engine RPM to give desired RPM at the roller. Normal operating speed must not exceed 540 RPM. If operating in heavy rock, reduce the speed slightly.

Move the tractor forward. Select a slow tractor speed and increase slightly until operation is satisfactory.

NOTICE Disengage the PTO any time that the roller is raised out of the ground.

Ground Speed

Ground speed should be between 3 and 5 MPH under normal conditions. In heavy rock, reduce the ground speed to 1 to 3 MPH.

Power Rake Angle Adjustment

The power rake may be angled up to 15 degrees left or right for placing material in a windrow.

For standard models, with the power rake angle cylinder connected to a tractor hydraulic control valve, move tractor control valve to select the desired angle. Return the tractor control to neutral to maintain the selected angle.

For flex models, auxiliary hydraulic circuit must be engaged. Position the angle toggle switch to angle right or left.

Power Roller

The roller should be level with the ground. To level rake from side to side, adjust one of the tractor 3-point lower lift arms.



Suggest:

If the above button click is invalid.

Please download this document

first, and then click the above link

to download the complete manual.

Thank you so much for reading

OPERATIONAL PROCEDURE

The power rake should be level front to back. Level the rake using the tractor 3-point top link, the 3-point lift arms, or the gauge wheels.

On standard models, to allow the roller to penetrate deeper into the ground, loosen the handle and raise the gauge wheels. On flex models, position toggle switch to raise gauge wheels. To achieve the opposite, lower the gauge wheels. Be sure to check the air pressure in each tire regularly so that an even, consistent grade will be maintained.

Barrier (Barrier adjustment location is shown on page 20.)

The normal gap between the roller and barrier for average conditions is about 1-1/4". This gap can be adjusted by rotating the barrier and pinning in desired position. A wider opening will allow more dirt and rock to pass through, allowing wet soil to dry for final raking. For finer raking, reduce the gap. (Be careful not to let roller hit barrier). The gap should be the same all the way across.

OPERATING DEPTH

When power raking, the depth will determine how much dirt is carried ahead of the roller. The ideal depth will vary with conditions and can be anywhere from skimming the surface to about 3 inches deep. See instructions in "Power Roller" above to set roller depth.

When making the first windrow, the level of dirt may be halfway up on the barrier. When moving the windrow two or three times, the level of the dirt may be to the top of the barrier. However, try to prevent material from flowing over the top.

The power rake allows fast raking of large areas of ground by being able to move windrows several times. Of course, the volume or density of the material being raked will dictate how many times a windrow can be moved.

Soil can be removed from the windrow of rocks by moving it back and forth a few times onto the clean area. If dirt clods are a problem, running the tractor tire over the windrow and then moving it a final time will help to break up and cut down on dirt clods.

Endplates

The function of the endplates is to contain the material in front of the roller while the clean material passes between the roller and barrier.

With the endplates mounted in the operating position and the rake straight (endplates parallel with tractor tires), material can be moved along, filling in the low spots.

By decreasing the gap between the roller and barrier, more material can be pulled along.

When not using the endplates for operation, they can be placed in "storage" position, see page 30.

Make sure the disconnected power rake is stored on a hard, level surface. Use the endplates

<https://www.ebooklibonline.com>

Hello dear friend!

Thank you very much for reading.

Enter the link into your browser.

The full manual is available for immediate download.

<https://www.ebooklibonline.com>