

# Power Rake PR72, PR72S, and PR96 for 240, 250, 260, 270 and 4475, 5575, 6675, 7775, 8875 Skid Steers

(Serial No. 100100 – )

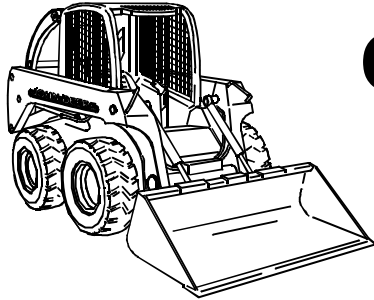

## OPERATOR'S MANUAL

John Deere  
Commercial Worksite Products

OMKV16793 D0

North American Version  
Litho in U.S.A  
English

# INTRODUCTION

**THANK YOU** for purchasing a John Deere product.

Read this manual and your vehicle manual thoroughly. Failure to do so could result in personal injury or equipment damage.



This manual should be considered a permanent part of your attachment and should remain with the attachment when you sell it.

Measurements in this manual are metric units and their U.S. customary equivalents. RIGHT-HAND and LEFT-HAND sides are determined by facing in the direction the machine will travel when going forward. When you see a broken line arrow ( - - - - - > ) it indicates the part it is pointing to is hidden.

Record identification numbers below. Be sure to record all the numbers to help in tracing the machine if it is stolen. You also need to give these numbers to your dealer when you order parts.

**Date of Purchase:**  
\_\_\_\_\_

**Dealer Name:** \_\_\_\_\_ **Phone:** \_\_\_\_\_

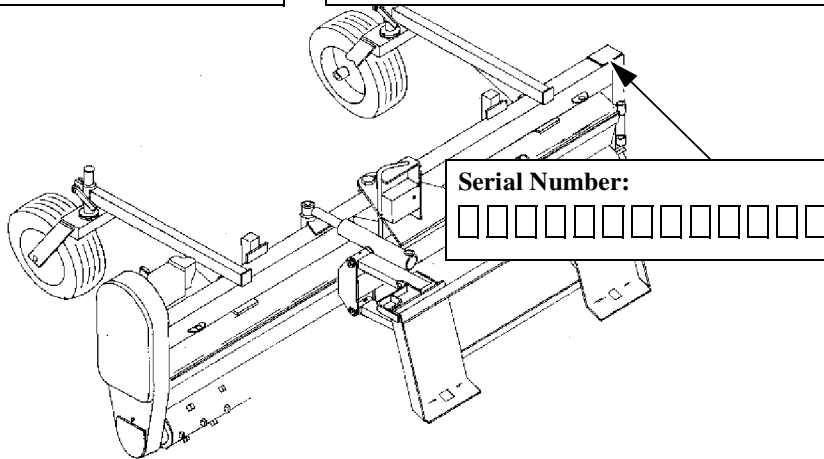

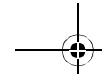

# TABLE OF CONTENTS

	Page
<b>Safety Signs</b> .....	<b>1</b>
<b>Controls</b> .....	<b>4</b>
<b>Installing</b> .....	<b>5</b>
<b>Removing</b> .....	<b>10</b>
<b>Operating</b> .....	<b>12</b>
<b>Service Machine Safely</b> .....	<b>24</b>
<b>Service Interval Chart</b> .....	<b>27</b>
<b>Service</b> .....	<b>28</b>
<b>Troubleshooting</b> .....	<b>32</b>
<b>Storing Machine</b> .....	<b>33</b>
<b>Assembly</b> .....	<b>34</b>
<b>Specifications</b> .....	<b>39</b>
<b>Warranty</b> .....	<b>46</b>
<b>Index</b> .....	<b>47</b>
<b>John Deere Service Literature</b> .....	<b>54</b>

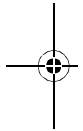

All information, illustrations and specifications in this manual are based on the latest information at the time of publication. The right is reserved to make changes at any time without notice.

COPYRIGHT© 2000  
John Deere Commercial Worksite Products  
Knoxville, Tennessee  
All rights reserved  
Previous Editions  
COPYRIGHT© 1999



**<https://www.ebooklibonline.com>**

Hello dear friend!

Thank you very much for reading.

Enter the link into your browser.

The full manual is available for immediate download.

**<https://www.ebooklibonline.com>**

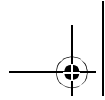

# NOTES

---

---

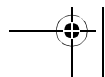
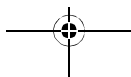
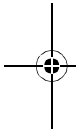

## SAFETY SIGNS

### Safety-Alert Symbol

Read and recognize safety information. Be alert to the potential for personal injury when you see this safety-alert symbol.

On your attachment safety labels, the words DANGER, WARNING, and CAUTION are used with this safety-alert symbol. DANGER identifies the most serious hazards. In this manual, the word CAUTION and this symbol call attention to safety messages.

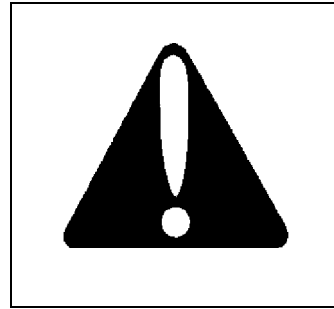

### Attachment Safety Labels

#### WARNING: Avoid Injury or Death

- Do not allow anyone to operate the Power Rake or skid steer who has not been properly trained in its safe operation and has not read and understood the operator's manual.
- Before attaching, check skid steer lift capacity to ensure its ability to safely handle the weight.
- Do not operate without guards/shields in place, and in good working order.
- Stop all moving parts including skid steer engine before cleaning, unplugging, adjusting and/or performing maintenance.
- Keep bystanders 10 feet from Power Rake when in operation.
- Failure to follow the above safety suggestions and those in the operator's manual can result in serious injury or death.

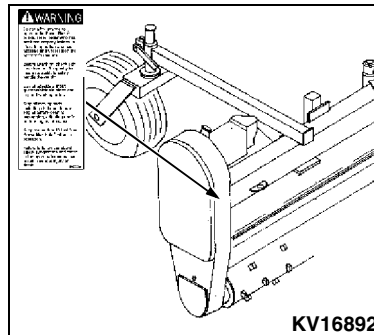

## SAFETY SIGNS

### **DANGER: Rotating Part Hazard**

- Keep hands, hair and clothing away from moving parts.
- Close and secure all shields before operating.
- Failure to do so could result in serious injury or death.

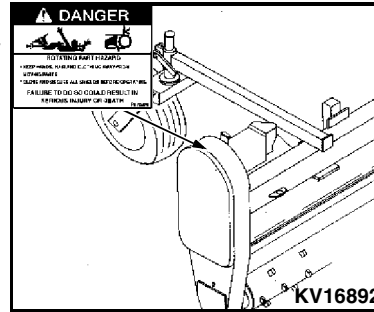

### **IMPORTANT: Check Oil Level Daily**

- Use GL5 Gear Lubricant 85W140 gear oil.

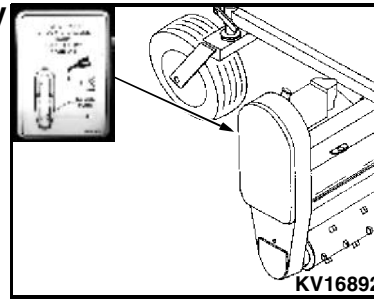

### **DANGER: Flying Parts and Rotating Parts**

- Stay at least 3 m (10 ft.) away from operating equipment.
- Flying objects and rotating parts can cause injury or death.
- Stop engine before cleaning or servicing.
- Keep all guards in place.

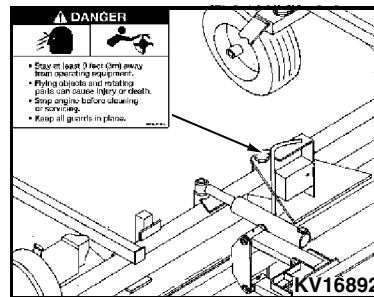

## SAFETY SIGNS

### Lockout Float Pin (PR72 & PR96 Only)

- For aggressive raking

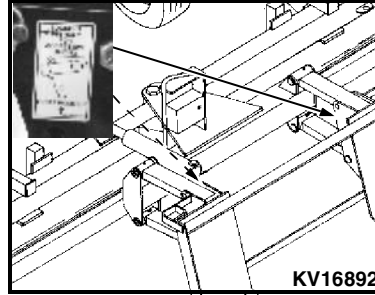

### WARNING: Pinch Point (PR72 & PR96 Only)

- Keep clear during operation.

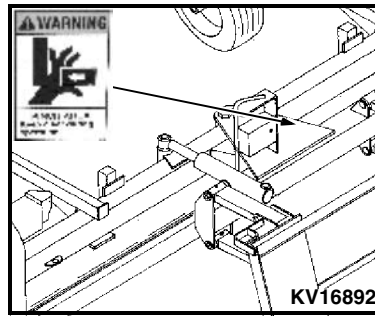

## CONTROLS

### Actuator Switches (Optional\*- PR72 & PR96 Only) (Not Applicable for Straight Power Rake) (200 Series Only, Not Available on 75 Series)

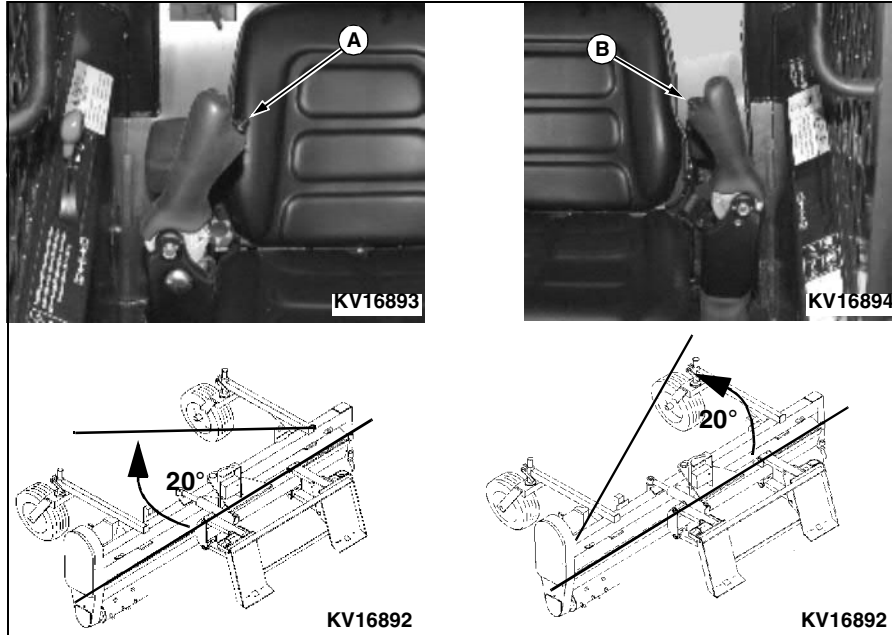

- A – Pivots power rake to the right**
- B – Pivots power rake to the left**

\*Requires that skid steer has 12-Volt power supply kit installed (optional). 12-Volt power supply kit is NOT required for rotation of roller. 12-Volt power supply kit is required to angle power rake.

## INSTALLING

### **Park Skid Steer Safely**

1. Stop skid steer on firm, level surface. Do not park on a slope.
2. Lower boom and attachment to the ground.
3. Engage the park brake.
4. Stop the engine. Release the seat belt.
5. Remove the key.
6. Before you leave the operator's seat, wait for engine and all moving parts to STOP.

### **Avoid High Pressure Fluids**

- Escaping fluid under pressure can penetrate the skin causing serious injury. Avoid the hazard by relieving pressure before disconnecting hydraulic or other lines. Tighten all connections before applying pressure.
- Search for leaks with a piece of cardboard. Protect hands and body from high pressure fluids.
- If an accident occurs, see a doctor immediately. Any fluid injected into the skin must be surgically removed within a few hours or gangrene may result. Doctors unfamiliar with this type of injury should reference a knowledgeable medical source. Such information is available from Deere & Company Medical Department in Moline, Illinois, U.S.A., 1-800-822-8262.



## INSTALLING

### Using QUIK-TATCH™ Attachment Mounting System



**CAUTION:** To avoid injury:

- **DO NOT** try to latch or unlatch handles from the cab.
- **Be careful not to pinch hands between latch handle and step or latch handle and attachment.**

#### To install power rake:

1. Stop skid steer, lower boom, engage park brake, stop engine, release seat belt, and exit skid steer.
2. Lift latch handles (A) up to the UNLATCHED position. Be sure the latch handles are all the way up so the lock pins are fully retracted.
3. Enter skid steer, fasten seat belt, start engine, and disengage park brake.
4. Tilt QUIK-TATCH™ mounting plates (B) forward.

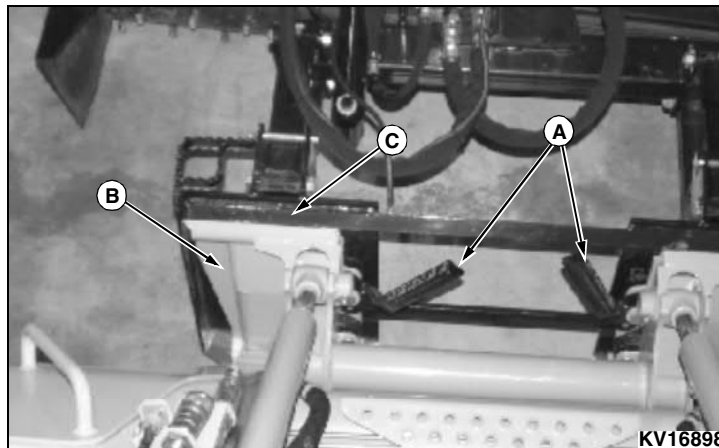

5. Drive forward, slowly raise boom, and guide the top of the mounting plates into the attachment mounting brackets (C).
6. Raise and tilt back the mounting plates. The back of the attachment should rest against the front of the mounting plate.

## INSTALLING

7. When the attachment is fully supported, lower the boom until the boom is resting on the boom stops.

8. Tilt the attachment out, stopping with the bottom edge of attachment about 50 mm (2 in.) from the ground.

9. Engage the park brake, turn off the engine, release the seat belt, and exit the skid steer.

10. Push the two latch handles (A) down to lock the attachment to the QUIK-TATCH™ mounting plates.

11. Enter the skid steer, fasten the seat belt, start the engine, and disengage the park brake.

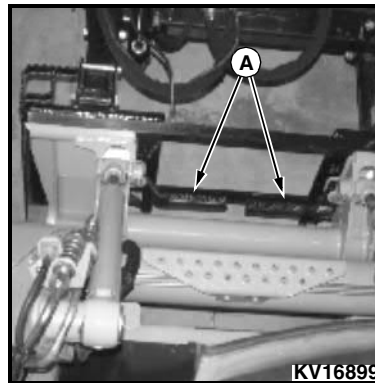

12. Activate the lift cylinders to raise attachment and extend bucket cylinders to tilt attachment at a slight downward angle so that the bottom of the QUIK-TATCH™ is visible.

13. Visually inspect the attachment mechanism to verify that pins are fully engaged in slots on the back of the attachment.

14. Connect hydraulic lines.



**CAUTION:** To avoid injury, be sure pins and latch handles are secure before operating boom and bucket.

**If attachment is not securely latched follow the steps to remove and then repeat installation procedure.**

## INSTALLING

### Attaching Power Rake Hydraulic Lines



**CAUTION:** Relieve hydraulic pressure before connecting or disconnecting auxiliary hydraulic lines.

**To relieve hydraulic line pressure:**

#### 200 Series

1. Sit in operator's seat.
2. Unlock handle from neutral position:
  - Turn key (A) to the right.
3. Move handle down toward seat and up away from seat several times.

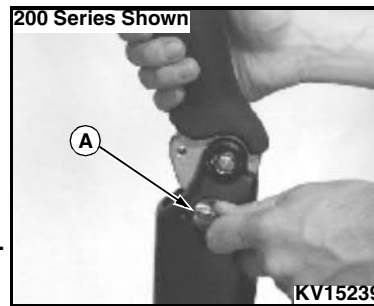

#### 75 Series

1. Sit in operator's seat.
2. Unlock handle from neutral position:
  - Push lock pin (B) down.
3. Move handle down toward seat and up away from seat several times.

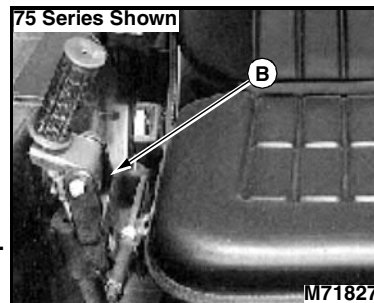

## INSTALLING

### To attach hydraulic lines:

1. Connect quick-disconnect couplers from power rake to skid steer.
2. Push couplers together with a firm continuous motion until couplers lock into place.

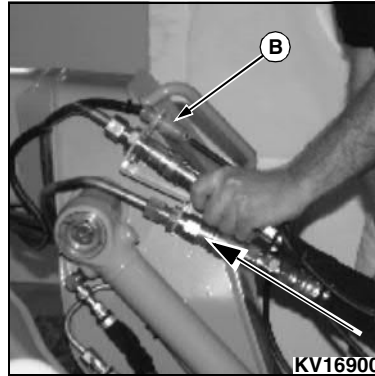

### To attach power rake 12-Volt connector (if equipped): (PR72 & PR96 Only) (200 Series Only)

**NOTE:** Requires that skid steer has 12-Volt power supply kit installed (optional). 12-Volt power supply kit is **NOT** required for rotation of roller. 12-Volt power supply kit required to angle power rake.

Align 12-Volt connector (B) from power rake to skid steer. Screw connectors together.

**IMPORTANT:** Inspect all lines and hoses for freedom of movement.

## REMOVING

### **Park Skid Steer Safely**

1. Stop skid steer on firm, level surface. Do not park on a slope.
2. Lower boom and attachment to the ground.
3. Engage the park brake. Release the seat belt.
4. Stop the engine.
5. Remove the key.
6. Before you leave the operator's seat, wait for engine and all moving parts to STOP.

### **Detaching Power Rake from Skid Steer**

1. Locate power rake and skid steer on firm level ground.
2. Lower skid steer boom arms.
3. Roll bucket cylinders forward or curl back as necessary so that power rake is level with the ground.
4. Engage park brake, and stop the engine.
5. Relieve hydraulic line pressure by actuating auxiliary control handle all the way down toward the seat and all the way up away from the seat several times.
6. Release the seat belt and remove the key. Exit the skid steer.  
Disconnect hydraulic lines from skid steer.

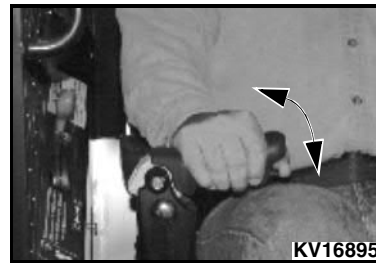

## REMOVING

**IMPORTANT:** Connect the two hydraulic lines from the power rake to each other.  
This will ensure connectors stay clean and allows hydraulic fluid to circulate due to thermal expansion.

7. To connect the hydraulic lines together:

- Hold hydraulic lines and place on your knees.
- Align the fittings.
- Using your arms and legs, push the hydraulic fittings together until the quick-disconnect couplers lock together.

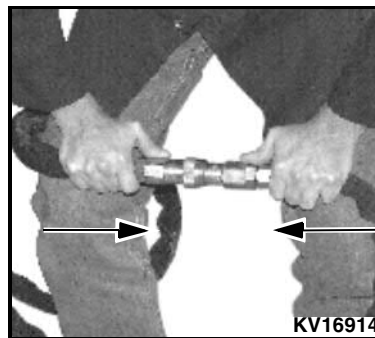

8. Disconnect 12-Volt connector (if equipped).

9. Lift handles (A) on QUIK-TATCH™ to release mounting plates from power rake.

10. Enter the skid steer, fasten seat belt, start the engine, and disengage park brake.

11. Slowly roll the bucket cylinders forward while slowly backing away from the power rake.

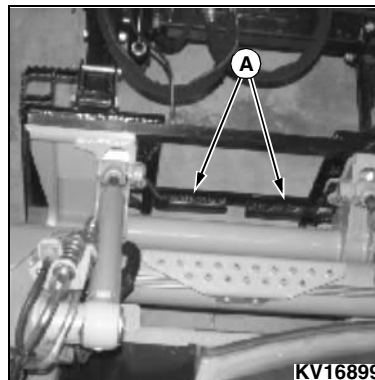

## OPERATING

### SAFETY

#### Operator Training Required



- Study the Skid Steer Operator's Manual. Know location and function of all controls. Know how to operate the skid steer before using this attachment.
- Study operation section of this manual before operating this attachment. Know location and function of all controls.
- Operate machine in an open, unobstructed area under the direction of an experienced operator.
- Operator experience is required to learn the moving, stopping, turning, and other operating characteristics of this attachment.



**CAUTION:** To avoid injury during operation do not permit bystanders within 3 m (10 ft.) of the power rake.

**Back up carefully. An operator must always look to each side and to the rear when backing up.**

## OPERATING

### Using The Auxiliary Control Handle

**NOTE: The 4475 requires Boom Hydraulics and Hand Control Handle Kit.**

The auxiliary hydraulic control handle (the right handle) directs hydraulic oil flow to operate different functions on a variety of attachments.

In the case of the power rake the auxiliary control handle operates the direction of roller rotation.

To unlock handle from neutral position:

#### 200 Series

1. Sit in operator's seat.
2. Unlock handle from neutral position:
  - Turn key (A) to the right.
3. Move handle down toward seat and up away from seat several times.

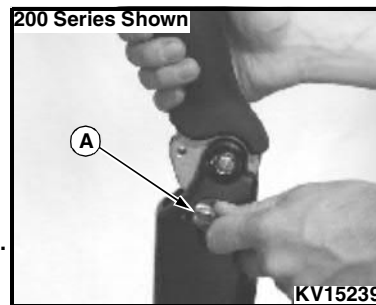

#### 75 Series

1. Sit in operator's seat.
2. Unlock handle from neutral position:
  - Push lock pin (B) down.
3. Move handle down toward seat and up away from seat several times.

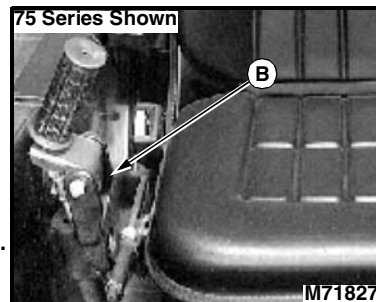



**Suggest:**

**If the above button click is invalid.**

**Please download this document**

**first, and then click the above link**

**to download the complete manual.**

**Thank you so much for reading**

## OPERATING

### FORWARD TRAVEL DIRECTION

Pivot handle (A) down toward seat to rotate the roller for forward travel.

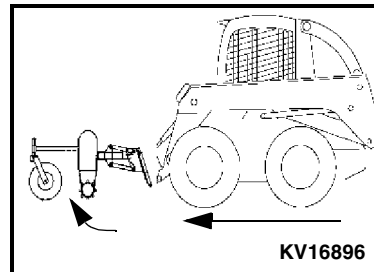
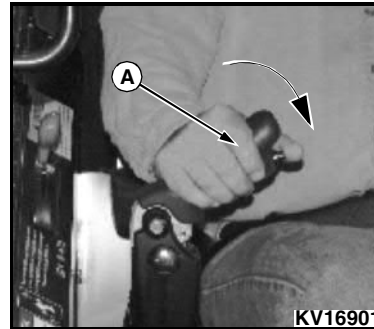

Pulling the handle all the way down toward the seat will put the control valve into detent position (B) to give continuous oil flow to an attachment. The handle will stay in this position until the operator moves the handle.

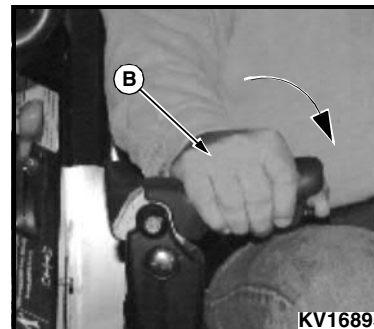

If the handle has not been moved all the way down into the detent position, it will automatically return to the center position when the operator lets go and will stop oil flow to the auxiliary couplers.

**NOTE: The detent position is for forward travel only.**

**<https://www.ebooklibonline.com>**

Hello dear friend!

Thank you very much for reading.

Enter the link into your browser.

The full manual is available for immediate download.

**<https://www.ebooklibonline.com>**