

# TRACTOR MODEL "M" SERIES



JOHN DEERE

## OPERATORS MANUAL TRACTOR MODEL "M" SERIES

OMTM31051 (01OCT51) English

OMTM31051 (01OCT51)

LITHO IN THE U.S.A.  
ENGLISH



## TO THE PURCHASER

We welcome you to our ever-growing family of John Deere tractor owners. We are confident that the dependable and economical performance of the John Deere Model "M" Tractor will prove that you made a wise choice.

The purpose of this manual is to acquaint you with the John Deere Model "M" Tractor. The manual explains how to operate and service your tractor, and how to maintain its high operating efficiency. Instructions are given clearly, with the intention of making these operations as easy as possible.

Keep this manual in a convenient place for quick and easy reference. Use it as a guide whenever questions arise. You have purchased a dependable, sturdy tractor, but only by operating and caring for it properly can you expect to receive the service and long life for which it was designed.

If in the future you need new parts to replace those that may be worn, insist on genuine John Deere parts. They are exact duplicates of the originals, made from the same patterns and of the same high-quality materials.

When ordering parts, be sure to give the serial number of your tractor. The illustration below shows where to find this serial number, which should be written NOW in the space provided in the illustration. Also write in date purchased and owner's name.

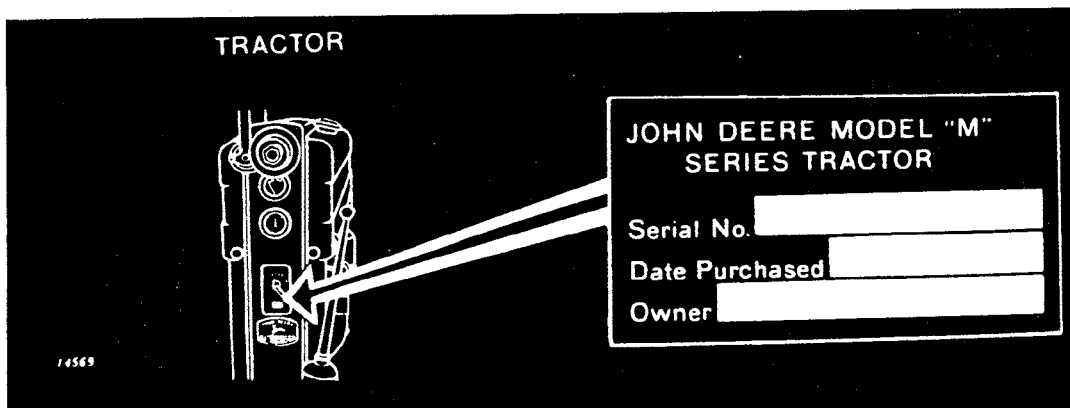

**• TABLE OF CONTENTS •**

SPECIFICATIONS AND DATA .....	4
CONTROLS AND INSTRUMENTS .....	6
OPERATION OF THE TRACTOR .....	14
LUBRICATION .....	28
SERVICE INSTRUCTIONS .....	42
SERVICE REMINDERS .....	66
STORING THE TRACTOR .....	67
SAFETY SUGGESTIONS .....	68
TRACTOR DIFFICULTIES .....	70
GENUINE PARTS AND DEALER SERVICE .....	75
INDEX .....	76

**<https://www.ebooklibonline.com>**

Hello dear friend!

Thank you very much for reading.

Enter the link into your browser.

The full manual is available for immediate download.

**<https://www.ebooklibonline.com>**

Even though your dealer has carefully inspected this tractor before delivering it to you, it is always good business to check the items which are encircled on the reproduction below of the envelope which contains this manual.

### TO THE NEW JOHN DEERE TRACTOR OWNER

Each John Deere Tractor is carefully designed, assembled, and given a complete test and final inspection at the factory before it is shipped. Our main ambition is to deliver tractors to new owners in the same mechanical condition as when shipped from the factory.

To enable us to fulfill this one ambition, this tractor was carefully inspected for irregularities that may have occurred in shipment. This inspection included a complete checking of the following:

- Wheel equipment: (Tire pressure) Wheel weights; Install calcium chloride solution.
- Radiator (Fill with water) or anti-freeze; Inspect shutter control, if installed.
- Air cleaner (oil level)
- Crankcase (oil level)
- Transmission oil level.
- Steering housing oil level.
- Touch-o-matic oil level.
- Rear wheel brakes.
- Clutch operation.
- Spark plug gaps.
- Carburetor setting (May require adjusting later according to fuel being used; see Instructions in Manual.)

- Engine speed and oil pressure.
- Inspect rubber hose connections.
- Check ignition timing.

#### Starting and Lighting Equipment

- Check new battery: (Check water level) Grease terminal posts.
- Check charging rate.
- Check starting motor for operation.
- Serial number entered in owner's register.

The above inspection made by *John Doe*  
Date *12-15-57* Dealer *Good Business Imp. Co.*

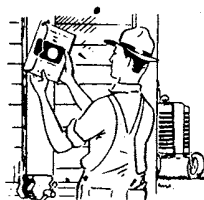

HANG THIS BOOK IN A  
HANDY PLACE

23062

We suggest this rechecking especially during freezing weather or when a period of time has elapsed between delivery and when you are ready to operate it. For complete starting information, see page 16.



We, your John Deere dealer, are mighty proud to add your name to our list of John Deere Tractor owners. Because we are interested in having you obtain from this new tractor all the comfort and long life that are built into it, we are pleased to discuss the following important maintenance operations:

- Controls.
- Breaking-in Period—Part Load, Open Throttle, Changing Oil.
- Method of Starting and Stopping Engine.
- Lubrication—Engine, Transmission, Touch-o-matic, Air Cleaner, Front Axle, and Oil Gauge.
- Cooling System—Adding Water, Shutter Control, Cleaning.
- Fuel System—Gasoline, Sediment Bowl and Trap, Carburetor Adjustment.
- Crankcase Breather Cap.
- Tires—Inflation, Inspection, Wheel Weights, Importance of Adding Calcium Chloride Solution.
- Distributor Care—Terminals Tight, Cleaning, Adjusting Points, Timing
- Rear Wheel Brakes—Adjustment.
- Clutch—Adjustment.
- Front Wheels—Cleaning, Adjustment and Spacing.
- Touch-o-matic Operation and Care
- Starter and Lights—Starting, Charging Rate, Changing Fuse, Battery Care.
- Tightening Bolts and Nuts.
- Safety in Operation—Selecting Proper Speed, Power Shaft.
- Keeping the Tractor Clean.
- Operating the Tractor.
- Appointment for After-Sales Service—not later than two weeks after delivery.

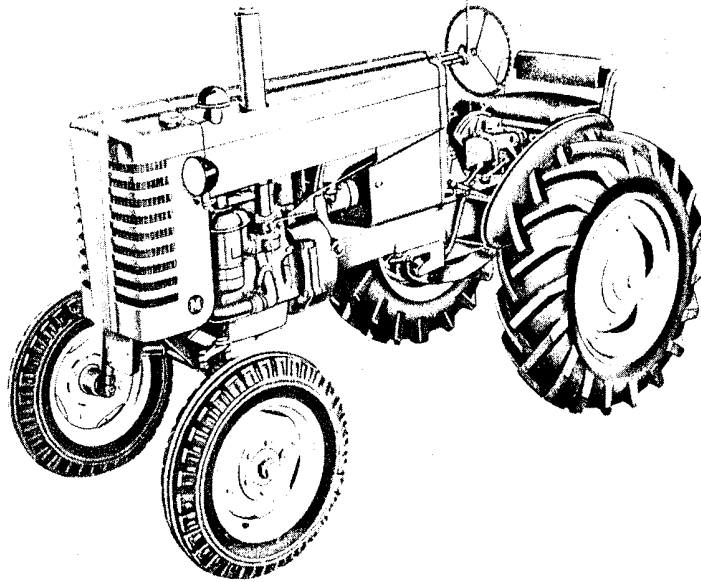

14570

## SPECIFICATIONS

### CAPACITY:

One 16" or two 12" plow bottoms; one 6' tandem disk harrow.

### SPEEDS:

Forward: 1½, 3¾, 4¼, 10 to 12 M.P.H. on 9-24. pneumatic tires (at normal governed speed).

Reverse . . . . . 1½ M.P.H.

### ENGINE:

Engine . . . . . Two vertical cylinders, cast-in-block; valve in head.

Engine speed . 1650 R.P.M. at rated load

Bore and stroke . . . . . 4" x 4"

Displacement . . . . . 101 cubic inches

Carburetor . . . . . Natural-draft type (adjustable load and idle jets).

Air cleaner . . . . . Heavy-duty, oil-wash type, center tube with stack.

Lubrication . . . . . Force-feed pressure system. Total capacity of oil system -- 5 quarts, including oil filter.

Cooling system . . . . . Thermo-siphon system. Total capacity 3½ gallons.

Fuel system . . . . . Gravity-feed system.

Fuel tank capacity--9 gallons.

Starting tank capacity (All-Fuel) --0.9 gallon.

Clutch . . . . . Single 10" plate automotive type, foot-operated.

Oil filter . . . . . Replaceable cartridge.

### TRANSMISSION:

Four speeds forward and one in reverse. Selective type spur gears, alloy steel, forged, cut and heat-treated.

Bearings . . . . . Constructed with 4 roller and 6 tapered roller bearings.

Oil capacity . . . . . Approximately 6½ U. S. quarts.

Transmission and differential are included in same case.

### REAR AXLES:

Each axle is 2" in diameter. Mounted on 2 tapered roller bearings.

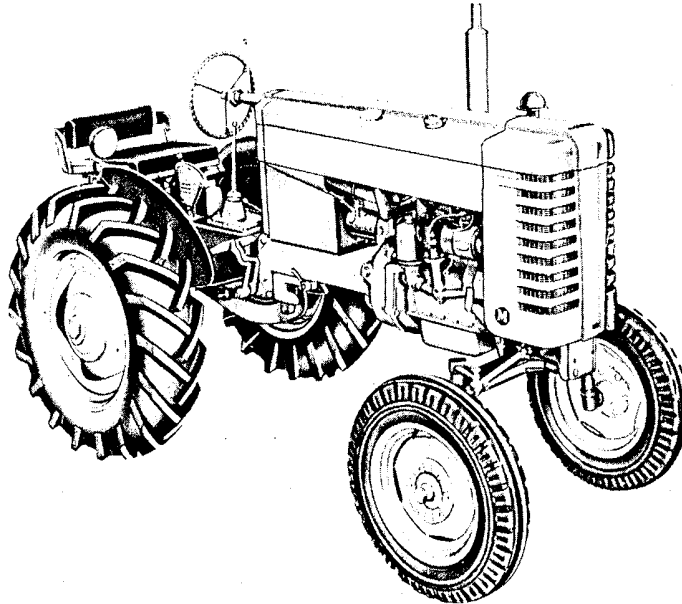

14571

## AND DATA...

### REAR WHEELS:

8, 9, or 10-24 4-ply tires mounted on pressed steel rim with mounting flange for attaching to cast-iron wheel web with 4 attaching nuts. Adjustments are made by shifting mounting positions of attaching flange.

### REAR WHEEL BRAKES:

Two self-energizing single disk-type differential brakes.

### FRONT WHEELS:

4:00 or 5:00 x 15" 4-ply rubber tires. Mounted on 2 tapered roller bearings. Pressed steel wheels.

### DIMENSIONS:

(On 10-24 pneumatic tires) Wheel base 70"; Over-all height 66½"; 56" height to radiator cap; Over-all length 110"; Over-all width 53½"; Rear wheel tread adjustment 38", 42", 48", 52"; Clearance 21"; Turning radius 8' 6".

### POWER TAKE-OFF:

Shaft diameter 1¾"; R.P.M. 550; Splined end is 25" above ground. Drawbar conforms with A.S.A.E. standards.

### REGULAR EQUIPMENT:

Starter, Generator, Battery; Oil Filter, Fuel Filter, Oil Wash Air Cleaner; Idle and load adjustable Carburetor; Distributor Ignition System; Dry plate semi-self adjusting Clutch; Individually operated self-energizing Brakes; Oil Pressure Gauge, Temperature Gauge, Ammeter, Generator Charge Control Switch, Thermo-Siphon Cooling System; Pressure Lubricating System; Exhaust Muffler, Touch-o-matic System, Power Take-Off, Adjustable Steering Shaft, Air-Bladder Seat, Drawbar Hitch Plate; "Air-Loc" Sheet Metal Fasteners; Fenders.

## CONTROLS ... INSTRUMENTS

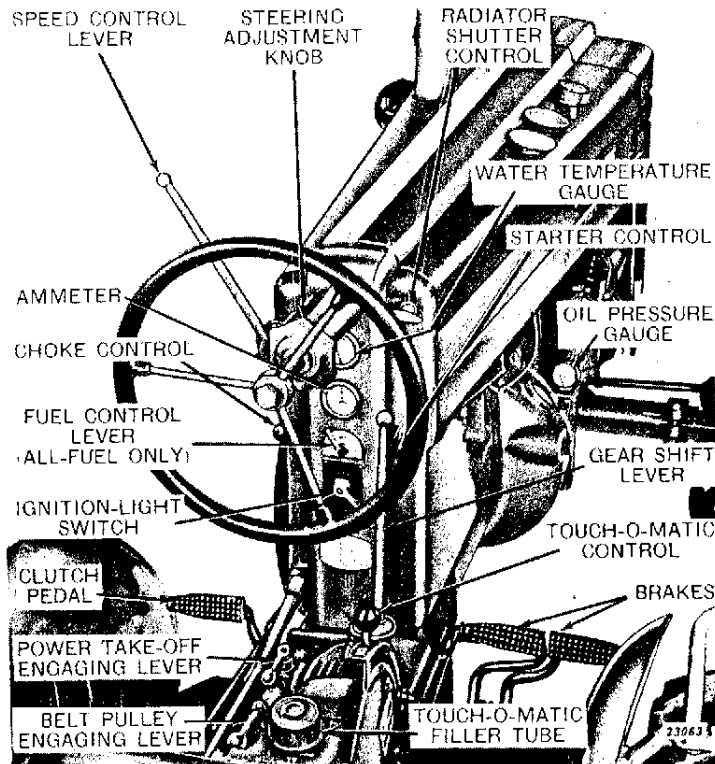

### *Starting and Operating Controls*

The quality and amount of work you do with your tractor not only depend on the use of proper equipment, but also upon ease and convenience of tractor operation. If you are in an uncomfortable position, if you have to fight the steering wheel, or if you can't see what you are doing, you are definitely handicapped.

Your John Deere tractor is as convenient to handle as your automobile. All controls are readily accessible. Shift lever, throttle, power shaft control, pulley drive control, and Touch-o-matic lever are reached easily from operator's seat. Under your feet are convenient dual brakes and clutch control. A platform is provided on which you can stand if you so desire.

Familiarize yourself with all controls provided for safe and easy operation of your new tractor. Regardless of your previous experience, carefully study this section covering controls before you operate your tractor.

## SEAT

The large air-bladder seat on this tractor gives you riding comfort which has been lacking on previous farm tractors. When inflated properly, the seat will cushion any shock or jar you may receive when operating in rough or boggy ground. It also gives a self-leveling effect when operating on an incline.

To increase or decrease amount of air in bladder, open slide fastener located at rear of seat and extend filler tube. It is not necessary to use a tire pump to inflate bladder. When adding air, be careful not to over-inflate. To remove air, depress valve.

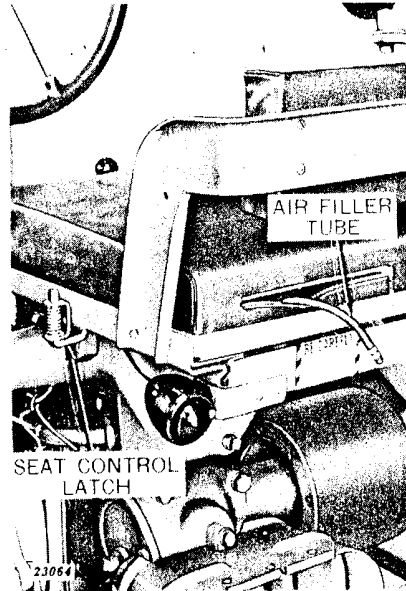

*Seat Control Latch and Air Filler Tube*

The seat is mounted on slide rails and is adjustable forward and backward to most comfortable operating position. Movement is controlled by a latch located on lower left-hand side of seat. When latch is depressed, seat may be moved to desired position. A safety stop screw is installed in slide to prevent seat from sliding off rails.

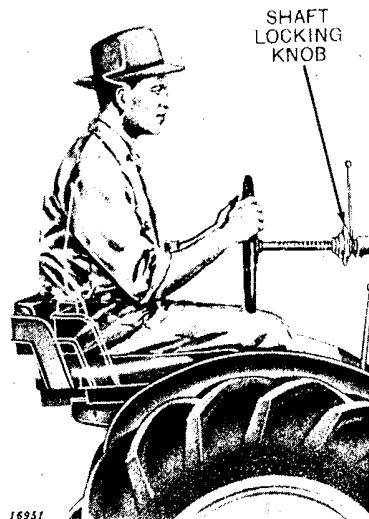

*Range of Adjustment*

## STEERING

The adjustable steering shaft allows steering wheel and shaft to be extended to any of several positions. Adjustment of steering wheel is controlled by a locking knob located on steering shaft near instrument panel. Turning knob clockwise locks shaft in desired position. Turning knob counterclockwise releases lock.

In some cases it is necessary to turn locking knob back (clockwise) slightly in order to release shaft locking mechanism fully.

### ENGINE SPEED CONTROL LEVER

The engine speed is controlled by a lever located on steering shaft support. Engine speed is controlled by raising lever to increase and lowering to decrease. This lever controls operation of governor, which in turn governs mixture of air and gasoline fed through the carburetor. (Linkage is adjusted at factory and should not be changed in field.)

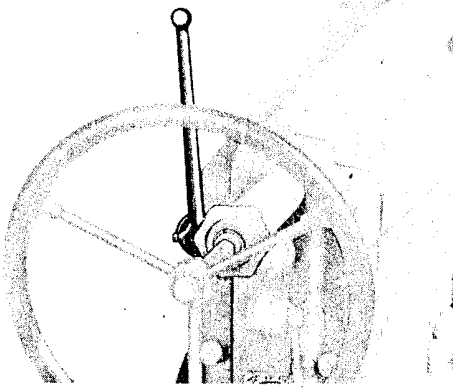

*Engine Speed Control Lever*

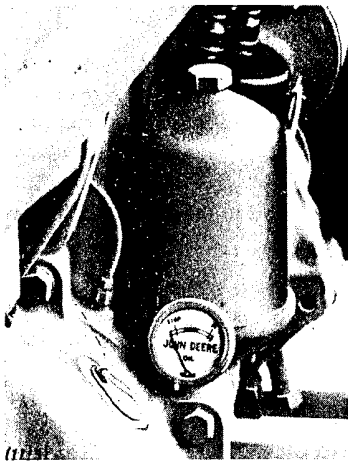

*Oil Pressure Gauge*

### OIL PRESSURE GAUGE

The oil pressure gauge is located on distributor side of engine and is attached to oil filter base. It has been placed in this position so it can easily be observed by tractor operator, while operating tractor. The oil pressure gauge, as its name implies, shows oil pressure through oil passages. It is not intended to show quality or quantity of oil in crankcase.

### BAYONET OIL GAUGE

This gauge is located to rear and below carburetor and shows quantity of oil in crankcase. It is extremely important that bayonet gauge be checked each time before starting engine, in order to insure proper engine lubrication. If gauge shows oil level at "ADD 1 QT." mark or below, oil MUST be added before starting engine. (Crankcase capacity 5 U.S. quarts, including 1 quart for oil filter.)

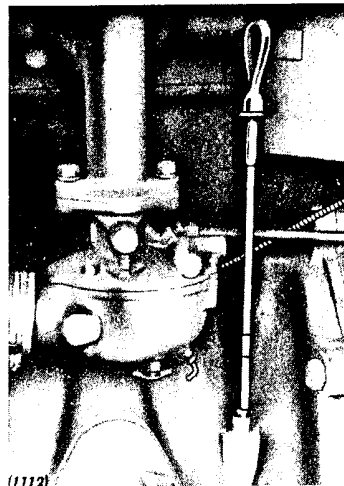

*Bayonet Oil Gauge*

## INSTRUMENT PANEL

### WATER TEMPERATURE GAUGE

The temperature gauge is located at top of the instrument panel just below speed control lever. It shows temperature of water in cooling system. This gauge should read "normal" during operation.

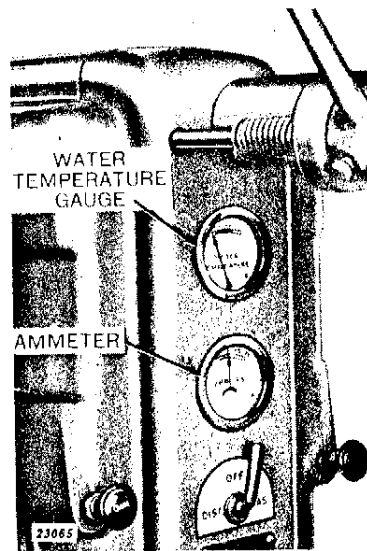

*Gauges*

### AMMETER

This gauge shows if generator is supplying a charge to battery and also the rate of charge or discharge of battery. The generator should be adjusted so that ammeter will show correct charge rate when engine is operating at fast idle, with lights off. Proper readings are approximately 2 amperes with switch at

low charge position (2nd position) and approximately 8 to 10 amperes at high charge position (3rd position). If ammeter should show no charge, it is a sign of possible generator failure. Engine should be stopped and cause of trouble ascertained. (See "Electric Generator" on Page 62 for correction.)

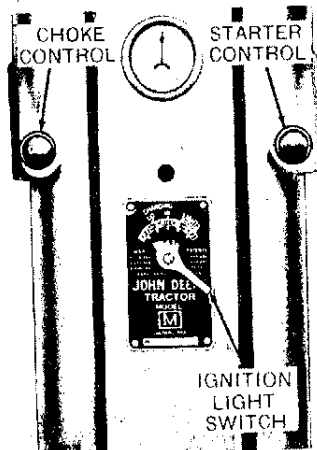

*Starting Controls*

### IGNITION-LIGHT SWITCH

The ignition and light switch controls ignition system as well as charge rate between generator and battery. It also is used to operate lighting system. The switch has five different operating positions as follows:

1.—(Starting with pointer of switch at far left.) Ignition is off. This position should always be used whenever shutting off engine so as to prevent discharge of battery when engine is not running.

2. Ignition on and generator charging **low** rate (approximately 2 amperes). This position should be used except when battery charge is very low, thus making additional charging necessary.

3. Ignition on and generator charging at **high** rate (approximately 8 to 10 amperes). This position is used if battery charge has become low due to excessive use of starter or lights. Do not operate on this position for too long a period of time; overcharge of battery will result.

4. Ignition on and lights on. This position is used when it is necessary to use lights while operating tractor. This position also gives a high rate of charge to eliminate drain of stored energy from battery by lights.

5. Ignition off and lights on. This position is used when lighting system is used, without operating engine. **This position must be used sparingly as it will sap strength from battery.** If battery should become run down from this use, it may be necessary to use starting crank to start engine. Run on high charge rate until battery is recharged.

*NOTE: Keep these various positions in mind at all times. (While operating tractor, it is essential to know which of the positions will keep battery charged to its peak without overcharging.)*

### CHOKE CONTROL AND STARTER CONTROL

These controls are located on either side of instrument panel slightly above the ignition-light switch. Starter control should be used sparingly so as not to weaken battery charge. Be careful when operating choke, as overchoking will flood carburetor.

### HAND CRANK

A hand crank is furnished with every tractor. It is used only in case of a weak battery or for turning engine when servicing or adjusting.

### BRAKE PEDALS

This tractor is equipped with self-energizing brakes. They are of the pressure-plate, single disk type, with linings which require no adjusting by the operator other than lengthening or shortening of brake pedal rod for proper pedal position when brakes are released. (Yearly check of brakes should be made by your John Deere dealer.) Brakes are individually controlled by dual pedals, located on lower edge of right-hand foot rest platform. Individual control of brakes allows you to use them for making shorter turns at corners. However, use caution in turning tractor when using the individually controlled brakes, especially if tractor is traveling at a high

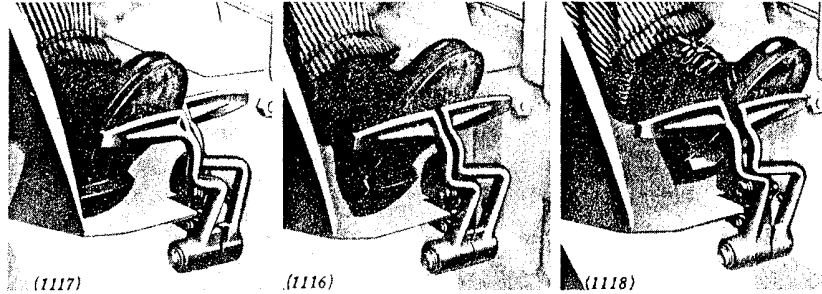

*Operation of Brake Pedals*

speed. By using both brakes simultaneously, you are assured of a quick and safe stop whether you are operating at low or transport speed. Brake pedals are equipped with individual cam locks, doing away with blocking wheels when stopping on a hill or adjusting machines. These locks are engaged by a quick push with the foot and are disengaged by depressing brake pedal and pressing on lever of cam lock. *NOTE: It is suggested that brakes be checked and readjusted by your John Deere dealer at end of each season's operation.*

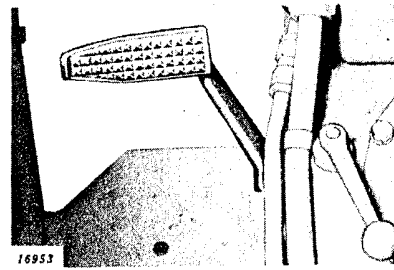

*Clutch Pedal*

### CLUTCH PEDAL

This tractor is equipped with a foot-type clutch, located on the left side and to the front of the transmission case.

### POWER SHAFT CONTROL LEVER

The power shaft is operated by a control lever located on left front of transmission case. Power shaft, located at rear of transmission case, is engaged by moving lever to the left.

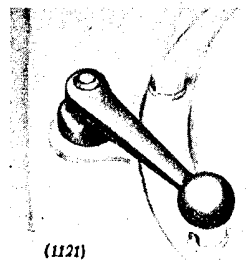

*Power Shaft Control Lever*

### GEAR SHIFT LEVER

Familiarize yourself with shifting diagram before you attempt to operate your tractor. Shifting diagram is cast on transmission shifting cover for your convenience.

If gears do not mesh freely when shifting, release clutch pedal, allowing clutch to engage slightly, and again depress clutch pedal. This permits gears to rotate until gear teeth line up better for easier shifting. Avoid clashing gears. This causes unnecessary wear on gears and possible gear tooth breakage.

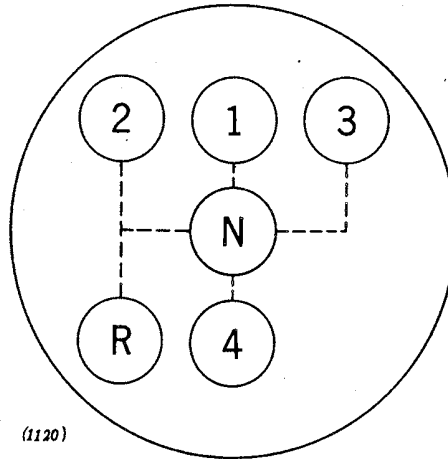

*Shifting Diagram*

### TOUCH-O-MATIC CONTROL LEVER

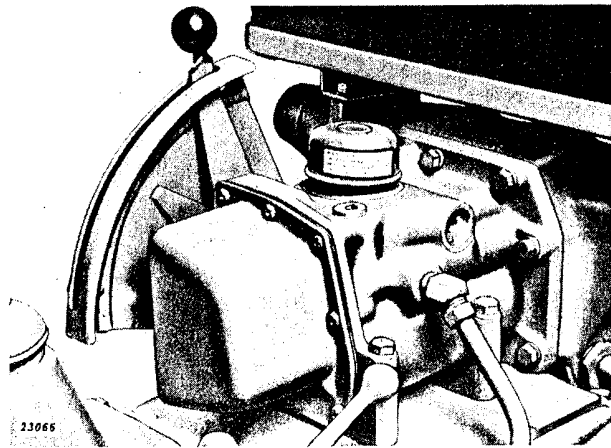

*Touch-o-matic Control Lever*

Touch-o-matic control lever is located in the quadrant immediately in front of the driver's seat. Moving lever to the rear raises the implement and moving lever to the front lowers implement. The stop on the quadrant may be set so that the implement always returns to the same operating level.

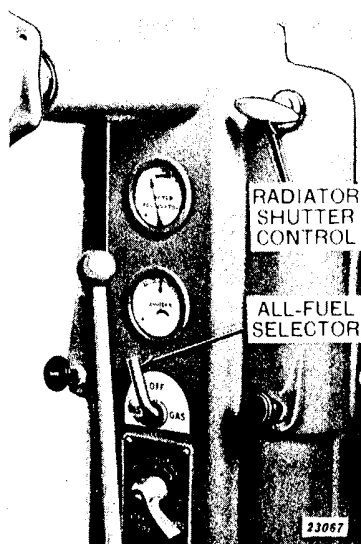

*All-Fuel Selector and  
Shutter Control*

### ALL-FUEL SELECTOR (All-Fuel Engine Only)

Control handle of the All-Fuel selector is located in center of instrument panel above starting switch. This control actuates a three-way control valve allowing operator to select either tractor fuel or gasoline from a normal driving position.

### RADIATOR SHUTTER

All-Fuel engines must be operated at a "Normal" temperature reading. The radiator shutter effectively controls the temperature at this range by means of a manually operated handle located at top right of instrument panel. To close shutter, pull handle out. To open shutter, push handle in. Handle must always be set in locked position after adjustment by turning ratchet notches to face upward.

## BELT PULLEY ATTACHMENT

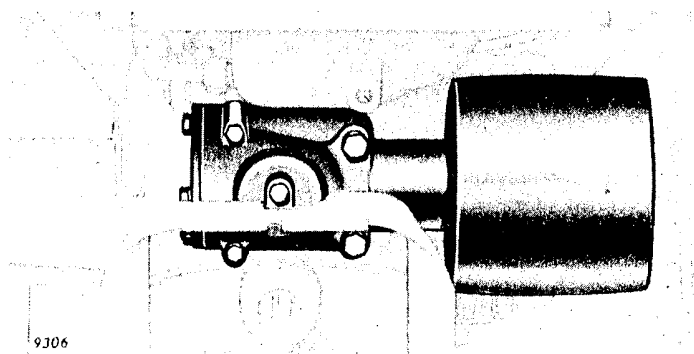

*Belt Pulley Attachment*

Your tractor may be equipped with a belt pulley if desired. Although belt pulley is considered an attachment, greater use of your tractor can be made if this attachment is obtained.

Belt pulley engaging lever is located on transmission case just to rear of power take-off engaging lever, and is operated in same manner, but in opposite direction, as power take-off engaging lever.

# OPERATION OF TRACTOR

## FUEL

Now that you are familiar with the controls, your next consideration before starting your tractor is the type of fuel you are going to use.

The gasoline engine is designed to operate economically on regular-grade gasoline. Third-grade gasoline or power fuels are not satisfactory for use in this engine.

The All-Fuel engine is designed to operate on gasoline, power fuel, tractor fuel, or kerosene, and no difficulty will be experienced with these fuels if the simple operating directions are followed.

## FUEL STORAGE

Fuel should be stored in a convenient place outside of buildings. If fuel drums are used, they should be located in a shady spot to prevent undue evaporation. Drums should be tilted slightly toward rear so that sediment will settle to rear and will not get out of drum through spigot. Hose nozzle should be capped when not in use so that dirt cannot get into it. Be sure drum vent plug is screwed in tight after using.

## RUN-IN PERIOD FOR NEW TRACTOR

Before your new tractor was shipped from the factory, all bearings and friction surfaces were correctly fitted, and crankcase filled with a "breaking-in" oil.

To be sure that all bearing surfaces will be properly lubricated, operate tractor on part-load for first 20 hours of operation. It will not be necessary to drain oil at this time; however, check should be made periodically to be sure that an adequate supply of oil is maintained in crankcase. If it becomes necessary to add oil during run-in period, S.A.E. 10W should be used. At end of 100 hours, "breaking-in" oil should be drained and crankcase filled with new oil in accordance with recommendations on page 30.

## BEFORE STARTING ENGINE

Before attempting to start engine or operate tractor, familiarize yourself with tractor and its various controls. Your John Deere dealer has shown you the important features of its operation and called your attention to various maintenance points which should be continually watched. There are, however, certain checking points which should be called to your attention

in order to prevent any future trouble or operational delays. The following instructions are very important. Make it a hard-and-fast rule to follow them before starting tractor; you will be compensated for this effort by longer tractor life and fewer operational delays.

(1) **Radiator.**

Check water level in radiator and, if necessary, add water to top of reservoir. (Use soft or rain water if possible.) When water has been drained to prevent freezing, *DO NOT* start engine before drain cock in lower water elbow has been closed and radiator refilled with water. (Capacity of cooling system, 3-1/2 U.S. gallons.)

(2) **Fuel Tanks.**

Check amount of fuel in tanks. Always use clean fuel of the type recommended for your tractor. See "Fuel" page 14. (Capacity of fuel tank approximately 9 U.S. gallons.) On All-Fuel tractors gasoline in the small front tank is used for starting and warming up the engine. Fill with clean gasoline. (Capacity, 0.9 U.S. gallon.)

(3) **Air Cleaner.**

Check oil in air cleaner for quality, weight, and amount. See recommendations on page 32.

(4) **Crankcase.**

Check crankcase oil level. If necessary, add a good grade of oil of the viscosity recommended in "Lubrication Chart" on page 30.

(5) **Tires.**

Check air pressure in pneumatic tires before moving tractor. Tires are overinflated at factory for shipment and must be checked before use. Inflate to correct pressure according to inflation charts, pages 57 and 58. Tire inflation should be checked at least every two weeks.

(6) **Touch-o-matic.**

Check oil supply in Touch-o-matic. If supply is low, add oil until reservoir is filled to proper level. Use clean oil of proper viscosity as recommended in "Lubrication Chart" on page 29.

(7) **Battery.**

Check solution level of battery. Battery condition should be checked at least once each week.

(8) **Fan.**

Check fan bearing for oil supply. Fan oil supply should be checked after every 20 hours of operation. To fill fan reservoir see "Lubrication" on pages 34 and 36.

(9) **Fuel Filter.**

Check fuel filter located beneath fuel tank. If filter shows sediment in glass bowl, clean by first turning off fuel supply at valve above filter bowl. Remove bowl and screen. Wash bowl and screen. Make certain a new gasket is in place before replacing filter bowl.

## STARTING GASOLINE ENGINE

*(See page 17 for starting "All-Fuel" engine.)*

1. Open shut-off valve above gasoline filter bowl.
2. Advance speed control lever to halfway open position.
3. Pull choke button outward full distance. (If tractor engine has been running a short time previously, it may not be necessary to use choke. It is advisable to try starting engine without choking in this case.)
4. Turn ignition and light switch to desired operating position. (See "Ignition and Light Switch," page 9, for explanation of different positions.)
5. Set gear shift lever in neutral position and release clutch by depressing clutch pedal.
6. Pull starter button outward. While operating this control, hold it in outward position until engine has had time to rotate several revolutions. Do not use a jerking action which places undue strain on starter drive spring as well as on operating parts of engine.
7. After engine has started, or after it has turned 4 or 5 revolutions, push choke button to its normal operating position. This will prevent flooding of carburetor. Usually enough gasoline for starting purposes has been drawn into combustion chamber by this time.
8. With engine running and speed control lever in the full open position (lever toward top) oil pressure gauge pointer should be within "NORMAL" markings on gauge. Allow engine to operate a few minutes before checking gauge. If pressure should show below normal or at red "STOP" position, ignition should be turned off immediately and cause of reduced oil pressure determined. (See "Tractor Difficulties," page 70.)
9. Regulate engine speed by using speed control lever.
10. The governor is adjusted to run engine at correct speed when tractor leaves factory: **1650 rpm** for full load and **1800 to 1850 rpm** for fast idle with speed control lever in full-open position. **CAUTION: Under no circumstances should engine be permitted to operate at a speed above 1850 rpm.** If it does, go to your John Deere dealer for proper adjustment.



**Suggest:**

**If the above button click is invalid.**

**Please download this document**

**first, and then click the above link**

**to download the complete manual.**

**Thank you so much for reading**

11. If crank is used for starting, set choke and switch controls before moving to front of tractor for cranking. Controls should be set in same position as for electric starting. Insert crank at front of tractor at bottom of radiator grille. **CAUTION: Make certain tractor is in neutral before attempting to crank.**

#### **WARM-UP PERIOD**

Before putting your tractor on full load or into high gear, be sure it is warmed up sufficiently. Oil will then circulate freely, preventing excessive wear on piston rings, cylinders, and bearings. Do not race engine during warm-up period. This wastes fuel.

### **STARTING ALL-FUEL ENGINE**

1. Turn fuel selector handle on instrument panel to "GAS" position and close radiator shutter. **CAUTION: If fuel selector handle was left in "DIST." position, turn handle to "OFF" position and drain carburetor before attempting to start tractor.**
2. Use the same procedure for starting as recommended for gasoline burning tractors. See page 16.
3. After engine has started and the temperature gauge reaches the "NORMAL" range, turn fuel selector to "DIST."
4. Adjust radiator shutter opening to maintain a "NORMAL" temperature reading on gauge when tractor is operating under all conditions.
5. Regulate engine speed by speed control lever.

### **OPERATING TRACTOR**

Your John Deere Model "M" Tractor has a range of four forward speeds and one reverse speed. Since this tractor was designed to give its greatest horsepower with speed control in full open position, it is advisable to select the gear which gives the desired speed rather than to adjust the speed control lever. Following this rule will give better performance, because engine will operate at its most efficient speed.

#### **DRIVING TRACTOR**

1. With engine running, release brake latches on both rear wheel brakes.

**<https://www.ebooklibonline.com>**

Hello dear friend!

Thank you very much for reading.

Enter the link into your browser.

The full manual is available for immediate download.

**<https://www.ebooklibonline.com>**