



**John Deere**

**Operator's Manual**

---

**Hydraulic Lift Reel  
and Hydrostatic Drive  
Reel Attachments**

---

**OM-H84013  
Issue I1**

---

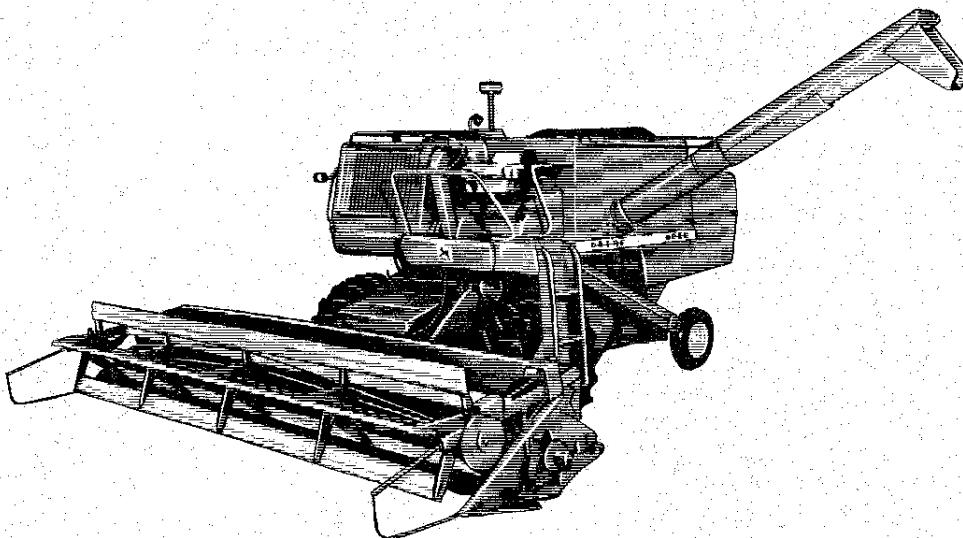



## To the Purchaser

These new hydraulic lift reel and hydrostatic drive reel attachments were carefully designed and manufactured to give years of dependable service. To keep them running efficiently, read the instructions in this operator's manual. Each section is clearly identified so you can easily find the information you need—whether it is operation or service. Read the Table of Contents to learn where each section is located.

 This safety alert symbol identifies important safety messages in this manual. When you see this symbol, be alert to the possibility of personal injury and carefully read the message that follows.

"Right-hand" and "left-hand" sides are determined

by facing in the direction the combine will travel when in use.

Record the date purchased in the space provided on page 24. Your dealer needs this information to give you prompt, efficient service when you order parts. If your reel attachments require replacement parts, go to your John Deere dealer where you can obtain Genuine John Deere parts—accept no substitutes.

The warranty on these reel attachments appears on your copy of the purchase order which you should have received from your dealer when you purchased the reel attachments.

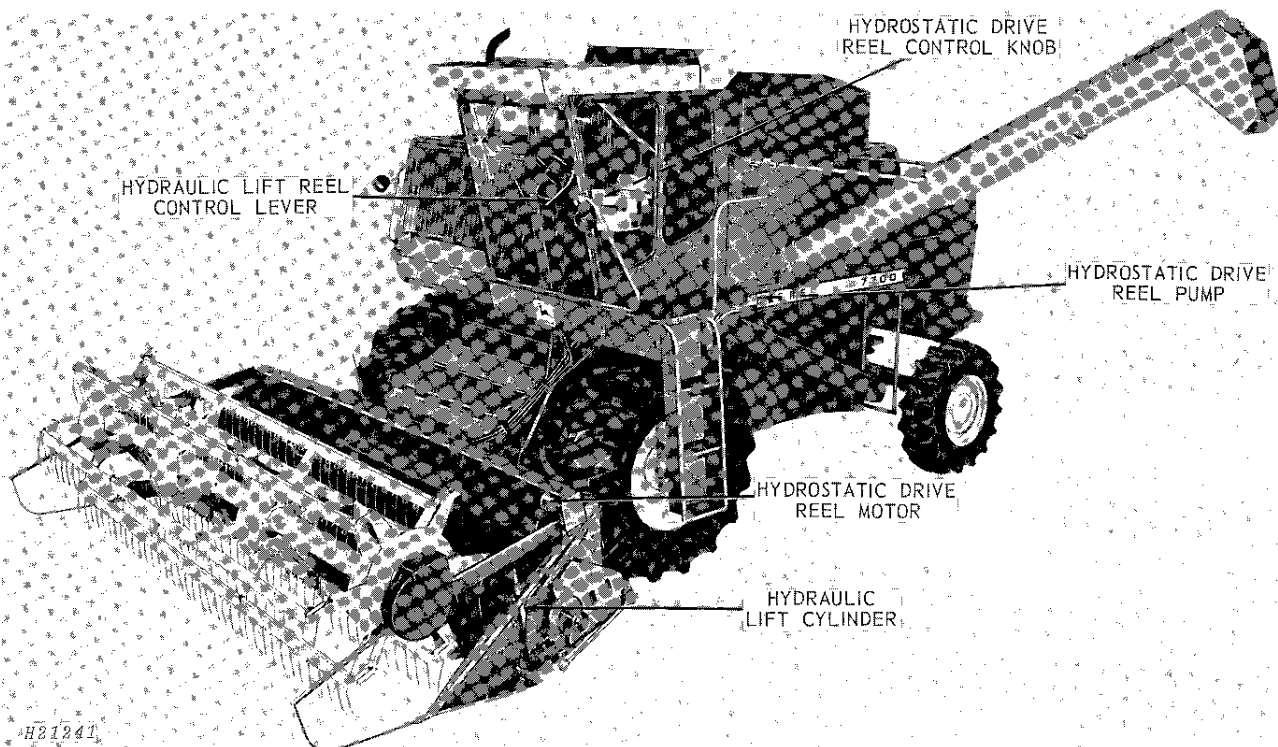

*John Deere 7700 Combine Equipped with Hydraulic Lift Reel and Hydrostatic Drive Reel Attachments*



# Contents

	Page
OPERATION .....	2
Hydraulic Lift Reel .....	2
Raising and Lowering .....	2
Speed of Lowering .....	2
Height Range .....	2
Leveling .....	2
Hydrostatic Drive Reel .....	3
SERVICE .....	4
Hydraulic Lift Reel .....	4
Bleeding the System .....	4
Control Valve .....	4
Connecting and Disconnecting Hoses .....	4
Hydrostatic Drive Reel .....	5
Tightening Pump Drive Belt .....	5
Tightening Reel Drive Chain .....	5
Connecting Hoses .....	5
ASSEMBLY AND INSTALLATION .....	6-22
Shipping Bundles .....	6-7
Installing Hydraulic Lift Reel .....	8-12
Installing Control Lever .....	8
Installing Cylinders, Tubes, and Hoses .....	9-12
Installing Hydrostatic Drive Reel .....	13-19
Installing Pump and Drive Belt .....	13
Installing Pump .....	13-14
Installing Valve and Hoses .....	14-16
Preparing Platform .....	17
Installing Motor and Drive Parts .....	18-19
Installing Both Hydraulic Lift Reel and Hydrostatic Drive Reel .....	20-22

**<https://www.ebooklibonline.com>**

Hello dear friend!

Thank you very much for reading.

Enter the link into your browser.

The full manual is available for immediate download.

**<https://www.ebooklibonline.com>**



# Operation

## HYDRAULIC LIFT REEL

### Raising and Lowering

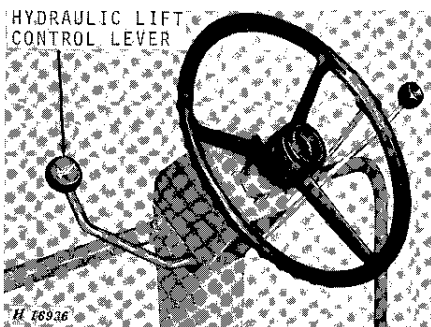

The hydraulic lift reel attachment enables the operator to control the height of the reel from the operator's platform.

The hydraulic lift reel is controlled by a lever on the left-hand side of the steering column.

To raise the reel, move the lever rearward. To lower the reel, move the lever forward. The lever automatically returns to neutral when released.

### Speed of Lowering

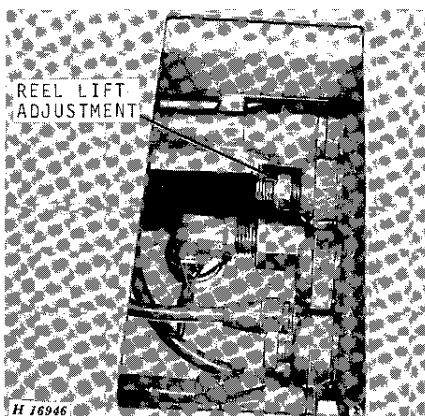

*Access Plate in Floorboard Removed*

The control valve, located under the operator's platform, has an adjustment to control speed of reel lowering. A nut located on the valve, can be turned in or out to change spool travel. By turning nut in, lower-

ing speed is decreased; by turning nut out, lowering speed is increased.

### Height Range

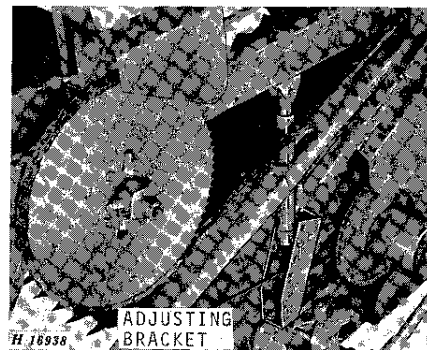

The height range of the reel is determined by the location of the bottom of the hydraulic cylinders in the adjusting brackets. Select the range that is right for the crop being harvested. Be certain that both cylinders are adjusted alike or the reel will not be level with the cutter bar.

**IMPORTANT:** When the hydraulic cylinders are completely retracted, be certain that the reel slats or tines (pickup reel) do not strike the cutter bar.

### Leveling

Always keep the reel level with the cutter bar. Be sure both hydraulic cylinders are located in the same hole in each adjusting bracket as explained above.

If, during operation, one end of the reel is lower than the other, raise the reel to its highest position or lower the reel to its lowest position. When both hydraulic cylinders are completely extended or retracted, the reel can then be returned to its original position and it will automatically be level.

If the reel cannot be leveled by extending or retracting the hydraulic cylinders as explained above, air may be trapped in the system. To bleed air from the hydraulic system at the slave cylinder, see page 4.

## HYDROSTATIC DRIVE REEL

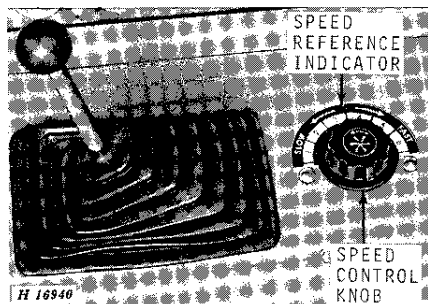

The hydrostatic drive reel attachment enables the operator to vary the speed of the reel without leaving the operator's platform.

The reel speed may be changed from 5 rpm to 40 rpm with a pickup reel or from 8 rpm to 64 rpm with a bat reel by turning the control knob on the console.

To increase the reel speed, turn the knob toward FAST. To decrease the reel speed, turn the knob toward SLOW.

Use the reference indicator as a guide to return to the reel speed that was previously found best for a particular crop or field condition.



# Service

## HYDRAULIC LIFT REEL

### Bleeding the System

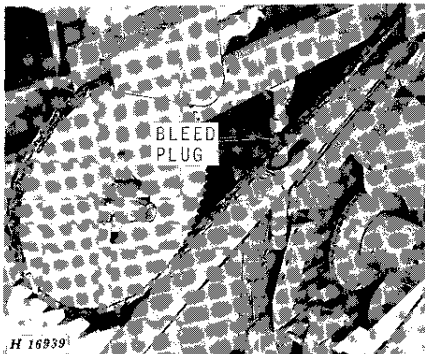

If the hydraulic hoses have been disconnected from the cylinder or if the reel will not remain level with the cutter bar, all trapped air must be removed from the cylinders and lines.

To remove trapped air, open the bleed plug at the upper end of the slave cylinder on the left-hand side of the cutting platform. Then, raise the reel. When oil flowing out the bleed plug opening is free of air bubbles, replace the bleed plug.

**IMPORTANT:** Be certain that the bleed plug is tight.

### Control Valve

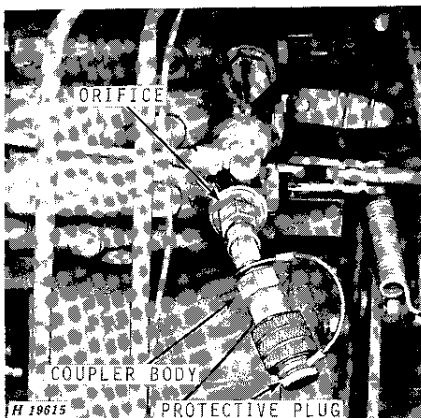

If for any reason, the coupler assembly is removed from the control valve, be sure the smooth side of the orifice is against the adapter when reinstalling adapter into control valve.

### Connecting and Disconnecting Hoses

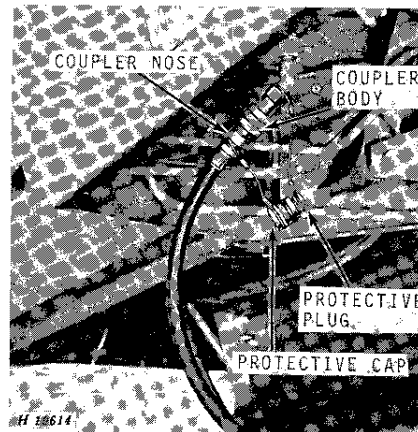

When the hydraulic hose is connected to control valve, snap protective cap and plug together as shown above.

Whenever the hydraulic hose is disconnected from control valve, be sure to insert protective plug into coupler body as shown in illustration at bottom of left-hand column and snap protective cap over coupler nose.

## HYDROSTATIC DRIVE REEL

### Tightening Pump Drive Belt

3300, 4400, and 6600 Combines

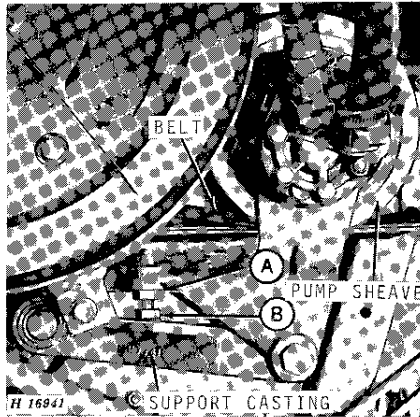

Loosen lock nut "A."

Turn cap screw "B" out against support casting, forcing pump sheave against belt.

Tighten belt until it will operate without slipping.

Tighten lock nut "A."

**IMPORTANT: Keep this belt tight at all times.**

7700 Combine

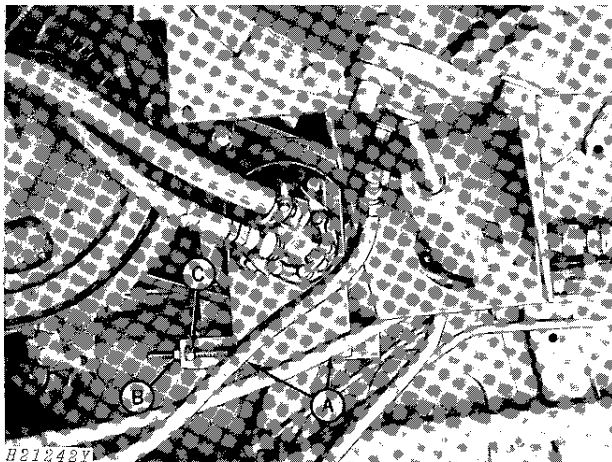

Loosen nuts "A" and nut "B."

Turn nut "C" until belt will operate without slipping.

Tighten nut "B" and nuts "A."

**IMPORTANT: Keep this belt tight at all times.**

### Tightening Reel Drive Chain

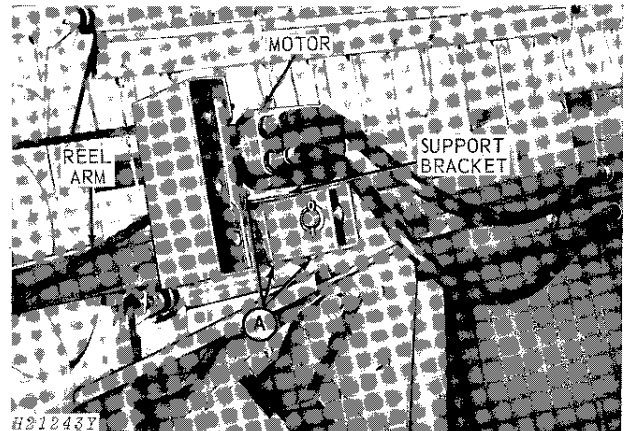

Loosen four carriage bolts "A."

Pull motor and support bracket rearward on reel arm until the chain will operate without climbing or jumping sprocket teeth.

Tighten carriage bolts "A."

### Connecting Hoses

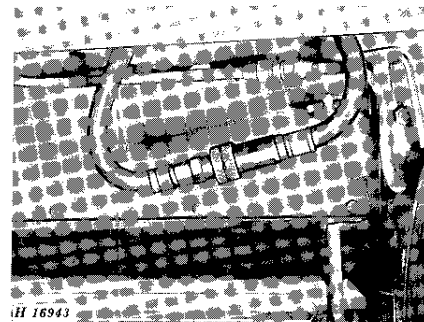

**IMPORTANT: When the hoses are disconnected from the oil lines to the motor, be sure to connect the pressure line to the return line at the combine as shown to assure a free flow of fluid to the reservoir. Failure to provide for the return flow will result in constant operation of the relief valve which will eventually overheat and damage the hydraulic system.**



**Suggest:**

**If the above button click is invalid.**

**Please download this document**

**first, and then click the above link**

**to download the complete manual.**

**Thank you so much for reading**



# Assembly and Installation

## SHIPPING BUNDLES

### Hydrostatic Drive Reel

Description	3300	4400	6600	7700
Hydraulic Hoses	BH 75098	BH 75098* BH 75099* *	BH 75099	BH 75099
Drive Assembly	BH 75523	BH 75523	BH 75523	BH 75523
Sprocket (10 Teeth)	AH 77367	AH 77367	AH 77367	AH 77367
Sprocket (30 Teeth)	AH 66504	AH 66504	AH 66504	AH 66504
Reel Drive Parts	BH 75086	BH 75086	BH 75086	BH 75506
Hydraulic Lines, 10-Ft. (2 used)	AH 77474	AH 77474	.....	.....
Hydraulic Lines, 13-Ft. (2 used)	AH 77475	AH 77475	AH 77475	AH 77475
Hydraulic Lines, 14-Ft. (2 used)	AH 77476	AH 77476	AH 77476	AH 77476
Hydraulic Lines, 15-Ft. (2 used)	AH 77477	AH 77477	AH 77477	AH 77477
Hydraulic Lines, 16-Ft. (2 used)	.....	AH 77478	AH 77478	AH 77478
Hydraulic Lines, 18-Ft. (2 used)	.....	AH 77479	AH 77479	AH 77479
Hydraulic Lines, 20-Ft. (2 used)	.....	AH 77480	AH 77480	AH 77480
Hydraulic Lines, 22-Ft. (2 used)	.....	.....	AH 77481	AH 77481
Hydraulic Lines, 24-Ft. (2 used)	.....	.....	.....	AH 77482

\* Use with regular length feeder house

\* \* Use with long feeder house

**<https://www.ebooklibonline.com>**

Hello dear friend!

Thank you very much for reading.

Enter the link into your browser.

The full manual is available for immediate download.

**<https://www.ebooklibonline.com>**