

# Hydraulic Breaker HB15, HB30, HB50 and HB75 for 240, 250, 260, 270 and 4475, 5575, 6675, 7775, 8875 Skid Steers

(Serial No. 100100 – )

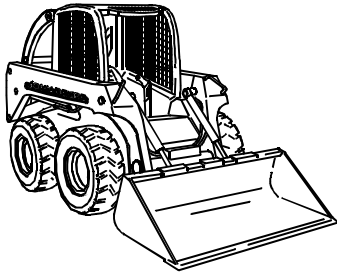

## OPERATOR'S MANUAL

John Deere  
Commercial Worksite Products

OMKV16791 C9

North American Version  
Litho in U.S.A  
English

# INTRODUCTION

---

---

**THANK YOU for purchasing a John Deere product.**

Read this manual and your vehicle manual thoroughly. Failure to do so could result in personal injury or equipment damage.



This manual should be considered a permanent part of your attachment and should remain with the attachment when you sell it.

Measurements in this manual are metric units and their U.S. customary equivalents. RIGHT-HAND and LEFT-HAND sides are determined by facing in the direction the machine will travel when going forward. When you see a broken line arrow (----->) it indicates the part it is pointing to is hidden.

Record identification numbers below. Be sure to record all the numbers to help in tracing the attachment if it is stolen. You also need to give these numbers to your John Deere skid steer dealer when you order parts.

**DATE OF PURCHASE:**

\_\_\_\_\_

**DEALER NAME:**

\_\_\_\_\_

**DEALER PHONE:**

\_\_\_\_\_

**SERIAL NUMBER (A):**

\_\_\_\_\_

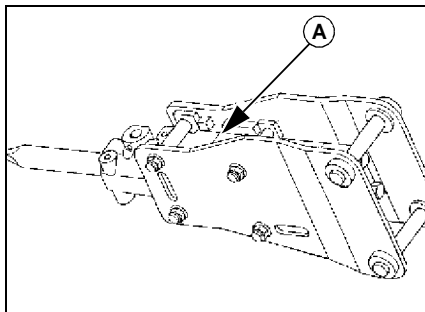

## TABLE OF CONTENTS

---

---

	Page
<b>Safety Signs</b> .....	<b>1</b>
<b>Preparing the Vehicle</b> .....	<b>2</b>
<b>Installing</b> .....	<b>3</b>
<b>Removing</b> .....	<b>8</b>
<b>Operating</b> .....	<b>10</b>
<b>Replacement Parts</b> .....	<b>23</b>
<b>Service Machine Safely</b> .....	<b>24</b>
<b>Service Interval Chart</b> .....	<b>27</b>
<b>Service</b> .....	<b>28</b>
<b>Troubleshooting</b> .....	<b>32</b>
<b>Storing Machine</b> .....	<b>34</b>
<b>Assembly</b> .....	<b>35</b>
<b>Specifications</b> .....	<b>36</b>
<b>Warranty</b> .....	<b>40</b>
<b>Index</b> .....	<b>41</b>
<b>John Deere Service Literature</b> .....	<b>45</b>

All information, illustrations and specifications in this manual are based on the latest information at the time of publication. The right is reserved to make changes at any time without notice.

COPYRIGHT© 1999  
John Deere Commercial Worksite Products  
Knoxville, Tennessee

**<https://www.ebooklibonline.com>**

Hello dear friend!

Thank you very much for reading.

Enter the link into your browser.

The full manual is available for immediate download.

**<https://www.ebooklibonline.com>**

# SAFETY SIGNS

---

## Safety-Alert Symbol

Read and recognize safety information. Be alert to the potential for personal injury when you see this safety-alert symbol.

On your machine safety labels, the words DANGER, WARNING, and CAUTION are used with this safety-alert symbol. DANGER identifies the most serious hazards. In this manual, the word CAUTION and this symbol call attention to safety messages.



## Attachment Safety Labels

### WARNING: Thrown Objects

- Do not operate near people.
- Debris can be thrown a long distance.

### DANGER

1. A projectile from the hammer, hammer tool, or work, and/or a swinging or falling hammer can be fatal to the operator or bystanders.
2. Do not operate hammer when bystanders are in work area.
3. The operator must be protected from flying debris. Use personal protection equipment.
4. Do not weld, cut with acetylene torch or hardface the hammer tool.

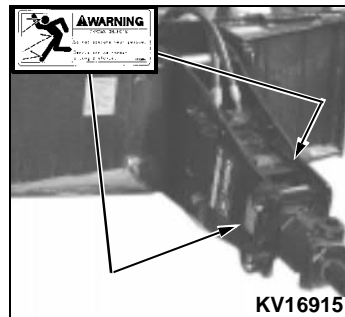

**IMPORTANT:** See OM for safety instruction details.

---

# PREPARING THE VEHICLE

---

## Skid Steer Equipment Requirements



**CAUTION:** To avoid injury skid steer must be equipped with the following:

- Demolition Door Kit
- Shoulder Belt Kit

The skid steer must be equipped with the Demolition Door Kit and the Shoulder Belt Kit. If your unit is not equipped with this equipment, see your authorized John Deere skid steer dealer.



Model 4475 skid steers also require boom hydraulics and hand control handle kits for hydraulic breaker operation. If your unit is not equipped with this equipment, see your authorized John Deere skid steer dealer.

### Ballasting

Rear ballast is not required to operate the hydraulic breaker, but may enhance vehicle stability. Ballasting kits are available from your authorized John Deere skid steer dealer.

# INSTALLING

---

---

## **Park Skid Steer Safely**

1. Stop the skid steer on a firm, level surface. Do not park on a slope.
2. Lower the boom to the ground.
3. Engage the park brake.
4. Stop the engine. Release the seat belt.
5. Remove the key.
6. Before you leave the operator's seat, wait for the engine and all of the moving parts to STOP.

## **Avoid High Pressure Fluids**

- Escaping fluid under pressure can penetrate the skin, causing serious injury. Avoid the hazard by relieving pressure before disconnecting the hydraulic or other lines. Tighten all connections before applying pressure.
- Search for leaks with a piece of cardboard. Protect hands and body from high pressure fluids.
- If an accident occurs, see a doctor immediately. Any fluid injected into the skin must be surgically removed within a few hours or gangrene may result. Doctors unfamiliar with this type of injury should reference a knowledgeable medical source. Such information is available from Deere & Company Medical Department in Moline, Illinois, U.S.A. Information may be obtained in the United States and Canada only by calling 1-800-822-8262.



# INSTALLING

## Using QUIK-TATCH™ Attachment Mounting System



- CAUTION:** To avoid injury:
- **DO NOT** try to latch or unlatch handles from the cab.
  - **Be careful not to pinch hands between latch handle and step or latch handle and attachment.**

### To install hydraulic breaker:

1. Stop the skid steer, lower the boom, engage the park brake, stop the engine, release the seat belt, remove the key, and exit the skid steer.
2. Lift the latch handles (A) up to the UNLATCHED position. Be sure the latch handles are all the way up so the lock pins are fully retracted.
3. Enter the skid steer, fasten the seat belt, start the engine, and disengage the park brake.
4. Tilt the QUIK-TATCH™ mounting plates (B) forward.

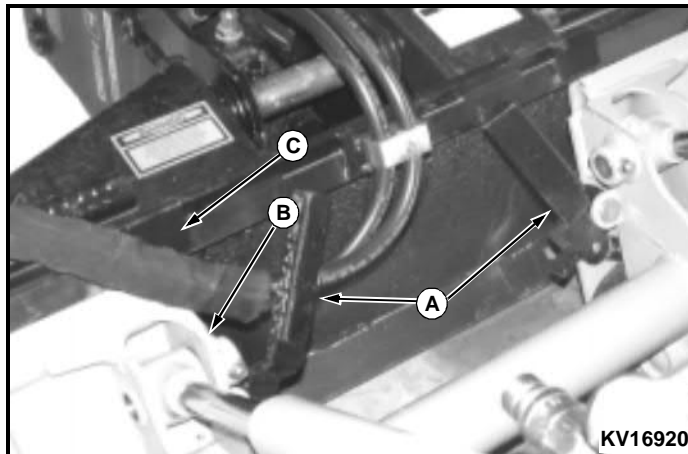

5. Drive forward, raise boom, and guide the top of the mounting plates into the attachment mounting brackets (C).
6. Raise and tilt back the mounting plates. The back of the attachment should rest against the front of the mounting plate.

## INSTALLING

---

---

7. When the attachment is fully supported, lower the boom until the boom is resting on the boom stops.

8. Tilt the attachment out, stopping with the bottom edge of attachment about 50 mm (2 in.) from the ground.

9. Engage the park brake, turn off the engine, release the seat belt, remove the key, and exit the skid steer.

10. Push the two latch handles (A) down to lock the attachment to the QUIK-TATCH™ mounting plates.

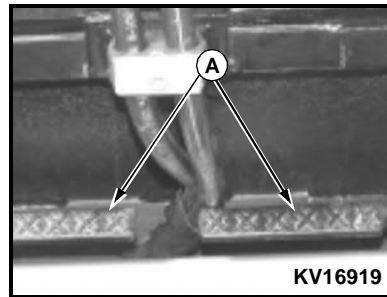

11. Enter the skid steer, fasten the seat belt, start the engine, and disengage the park brake.

12. Activate the lift cylinders to raise attachment and extend bucket cylinders to tilt attachment at a slight downward angle so that the bottom of the QUIK-TATCH™ is visible.

13. Visually inspect the attachment mechanism to verify that pins are fully engaged in slots on the back of the attachment.

14. Connect hydraulic hoses.



**CAUTION:** To avoid injury, be sure pins and latch handles are secure before operating boom and bucket.

If attachment is not securely latched follow the steps to remove and then repeat installation procedure.

# INSTALLING

## Attaching Breaker Hydraulic Lines



**CAUTION:** Relieve hydraulic pressure before connecting or disconnecting auxiliary hydraulic lines.

1. Relieve the hydraulic line pressure:

- Sit in operator's seat.
- Unlock the handle from the NEUTRAL position:
  - **200 Series:** Turn key (A) to the right.

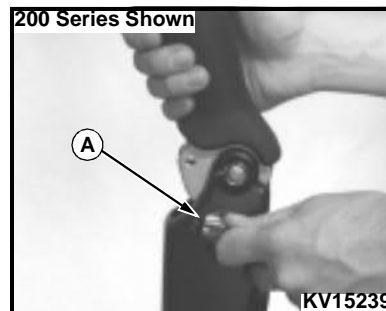

- **75 Series:** Push lock pin (B) down.
- Move the handle down toward the seat and up away from the seat several times.

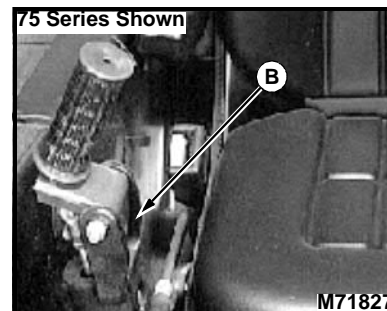

2. Route the hydraulic hoses (C) under QUIK-TATCH cross bar (D).

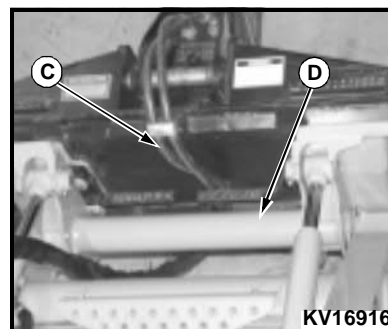

## INSTALLING

---

3. Install the quick-disconnect couplers together by pushing the couplers together with a firm continuous motion until couplers lock into place.



**IMPORTANT:** Inspect all lines and hoses for freedom of movement.

# REMOVING

---

---

## **Park Skid Steer Safely**

1. Stop skid steer on firm, level surface. Do not park on a slope.
2. Lower boom to the ground.
3. Engage the park brake.
4. Stop the engine. Release the seat belt.
5. Remove the key.
6. Before you leave the operator's seat, wait for engine and all moving parts to STOP.

## **Removing Breaker from Skid Steer**

1. Locate breaker and skid steer on firm level ground.
2. Roll bucket cylinders forward or curl back as necessary so that breaker is level with the ground.
3. Lower boom so that breaker is resting on the ground.
4. Engage park brake and stop the engine. Remove seat belt.
5. Relieve hydraulic line pressure by actuating control handle all the way down toward the seat and all the way up away from the seat several times.
6. Exit the skid steer. Disconnect hydraulic lines from skid steer



**IMPORTANT:** Connect the two hydraulic lines from the breaker to each other. This will ensure connectors stay clean and allows hydraulic fluid to circulate due to thermal expansion.

## REMOVING

---

7. To connect the hydraulic lines together:

- Hold the hydraulic lines and place them on your knees.
- Align the fittings.
- Using your arms and legs, push the hydraulic fittings together until the quick-disconnect couplers lock together.

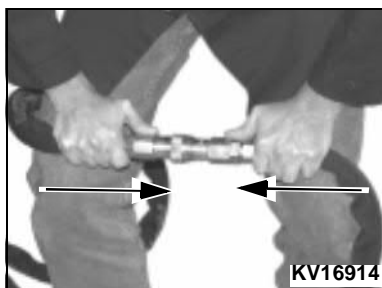

8. Lift the handles (A) on the QUIK-TATCH™ to release the mounting plates from the breaker.

9. Enter the skid steer, fasten seat belt, start the engine, and disengage the park brake.

10. Slowly roll the bucket cylinders forward while slowly backing away from the breaker.

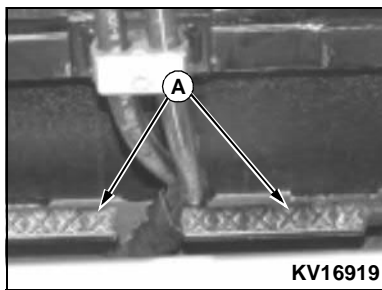

# OPERATING

---

---

## SAFETY

### Operator Training Required



- Study the Skid Steer Operator's Manual. Know location and function of all controls. Know how to operate the skid steer before using this attachment.
- Study operation section of this manual before operating this attachment. Know location and function of all controls.
- Operate machine in an open, unobstructed area under the direction of an experienced operator.
- Operator experience is required to learn the moving, stopping, turning, and other operating characteristics of this attachment.



**CAUTION: To avoid injury during operation do not permit bystanders in the work area.**

### Operate Safely

- Inspect the machine and attachment before you operate. Be sure all hardware is tight. Repair or replace damaged, badly worn, or missing parts. Be sure guards and shields are in good condition and fastened in place. Make any necessary adjustments before you operate.
- Keep people and pets out of the work area. Stop machine if anyone enters the area.
- DO NOT operate breaker unless it is properly installed on skid steer.
- Never operate breaker without demolition door and shoulder belt.
- Always close and secure demolition door and fasten shoulder belt before operating breaker.
- Only operate breaker from skid steer operator's seat.



**Suggest:**

**If the above button click is invalid.**

**Please download this document**

**first, and then click the above link**

**to download the complete manual.**

**Thank you so much for reading**

## **OPERATING**

---

---

- The point of the breaker should be angled away from the operator. This pushes the broken material into the opening and protects the operator from debris thrown out by the bit.
- Never operate the breaker with the bit spring pin or set pin removed.
- Always lower boom so breaker is resting on the ground before exiting skid steer.
- DO NOT leave skid steer unattended while it is running.
- Only operate during daylight or with adequate artificial light.
- Watch for overhead wires. Never touch wires with any part of the skid steer boom or breaker.
- DO NOT let anyone, ESPECIALLY CHILDREN, ride on the skid steer.
- DO NOT let children or an untrained person operate machine.
- ALWAYS check to the sides and rear of the skid steer before backing up.

### **Operating Tips**

- Break large objects from the outside edges and work inward.
- Open a small hole in the material first, then break to the opening.
- While breaking, “follow” the breaker with down pressure from the skid steer boom. Press the breaker into the material, always keeping the force aligned with the bit to prevent binding of the bit in the material. Listen for solid, fast blows.
- If the breaker blow frequency slows and the sound becomes a hollow “thunk”, more down pressure or realignment of the bit may be needed.
- Keep moving! Breaking in one spot for more than one minute only creates heat at the bit. Move frequently and do not take “bites” of material that are too large to be broken in a short time.

**<https://www.ebooklibonline.com>**

Hello dear friend!

Thank you very much for reading.

Enter the link into your browser.

The full manual is available for immediate download.

**<https://www.ebooklibonline.com>**