

GATOR®
Diesel
Utility Vehicle

Serial No. (08807-)

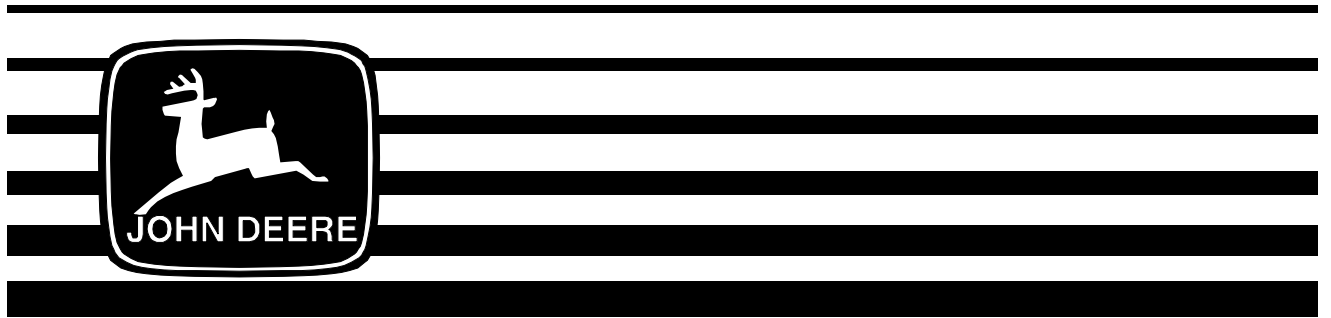

OPERATOR'S MANUAL

John Deere
Worldwide Commercial And
Consumer Equipment Division
OMM136976 K8

Export/European Version
Litho in U.S.A.
English

INTRODUCTION

READ THIS MANUAL carefully to learn how to operate and service your machine correctly. Failure to do so could result in personal injury or equipment damage. This manual and safety signs on your machine may also be available in other languages (see your John Deere dealer to order).

THIS MANUAL SHOULD BE CONSIDERED a permanent part of your machine and should remain with the machine when you sell it.

MEASUREMENTS in this manual are given in both metric and customary U.S. unit equivalents. Use only correct replacement parts and fasteners. Metric and inch fasteners may require a specific metric or inch wrench.

RIGHT-HAND AND LEFT-HAND sides are determined by facing the direction of forward travel.

SETTING FUEL DELIVERY BEYOND PUBLISHED factory specifications or otherwise overpowering will result in loss of warranty protection for this machine.

BEFORE DELIVERING THIS MACHINE, your dealer performed a predelivery inspection to ensure best performance.

THIS UTILITY VEHICLE IS DESIGNED SOLELY for use in customary agricultural and forestry operations, for park and amenity area maintenance, and for winter work. Use in any other way is considered as contrary to the intended use.

The manufacturer accepts no liability for damage or injury resulting from this misuse, and these risks must be borne solely by the user. Compliance with and strict adherence to the conditions of operation, service and repair as specified by the manufacturer also constitute essential elements for the intended use.

THIS UTILITY VEHICLE SHOULD BE OPERATED, serviced and repaired only by persons familiar with all its particular characteristics and acquainted with the relevant safety rules (accident prevention). The accident prevention regulations, all other generally recognized regulations on safety and occupational medicine and the road traffic regulations must be observed at all times.

Any arbitrary modifications carried out on this tractor will relieve the manufacturer of all liability for any resulting damage or injury.

INTRODUCTION

WRITE PRODUCT IDENTIFICATION NUMBERS (P.I.N.) in the space provided below. Accurately record all the numbers to help in tracing the machine should it be stolen. Your dealer also needs these numbers when you order parts. File the identification numbers in a secure place off the machine.

DATE OF PURCHASE:

DEALER NAME:

DEALER PHONE:

PRODUCT IDENTIFICATION NUMBER (A):

ENGINE SERIAL NUMBER (B):

IDENTIFICATION NUMBER FOR ROAD HOMOLOGATED GATOR (C):

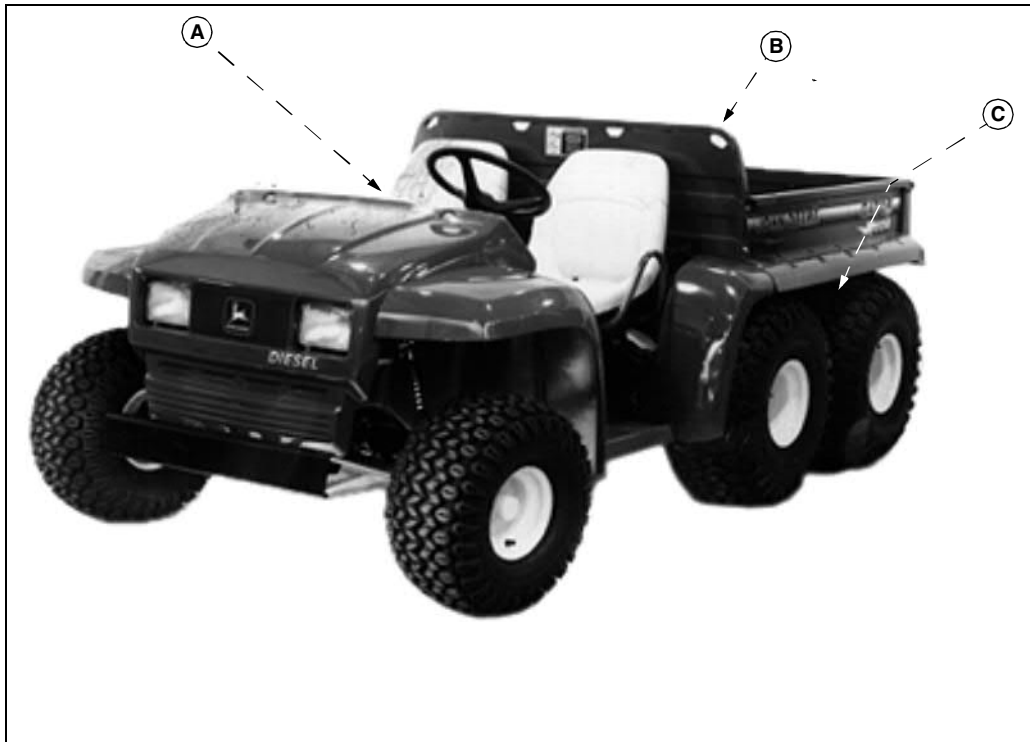

<https://www.ebooklibonline.com>

Hello dear friend!

Thank you very much for reading.

Enter the link into your browser.

The full manual is available for immediate download.

<https://www.ebooklibonline.com>

TABLE OF CONTENTS

Safety Signs	1
Controls	4
Operating Machine	6
Operating Road Homologated Features	33
Replacement Parts	41
Service Machine Safely	42
Service Interval Chart	45
Service Engine	48
Service Transmission	65
Service Electrical	73
Service Miscellaneous	84
Troubleshooting	91
Storing Machine	94
Assembly	97
Specifications	115
Index	126

All information, illustrations and specifications in this manual are based on the latest information at the time of publication. The right is reserved to make changes at any time without notice.

COPYRIGHT© 1998
Deere & Co.
John Deere Worldwide Commercial and
Consumer Equipment Division
Horicon, WI
All rights reserved
Previous Editions
COPYRIGHT© 1996

OMM136976 K8

SAFETY SIGNS

Pictorial Safety Signs

At several important places on this machine safety signs are affixed intended to signify potential danger. The hazard is identified by a pictorial in a warning triangle . An adjacent pictorial provides information how to avoid personal injury. These safety signs, their placement on the machine and a brief explanatory text are shown in this Safety Signs section.

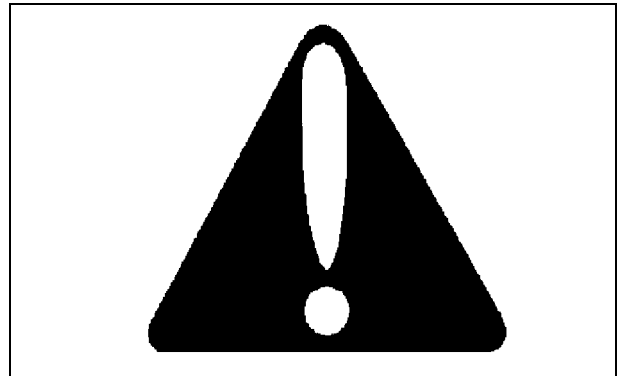

Park Vehicle Safely

Before leaving vehicle

- Stop Engine.
- Set Park Brake.
- Remove Key.



Read Operator's Manual

Careful read Operator's Manual before handling the machine. Observe instructions and safety rules when operating.



SAFETY SIGNS

WARNING: Young Drivers Increase Chance Of Death

- Young drivers may not be able to control vehicle.
- NO drivers younger than 16 years old.



WARNING: Riders Can Fall Off And Be Killed

- Maximum of one person to a seat.
- No riders in box or anywhere else.

Rollover Or Falling Off May Cause Death.

- Read Operator's manual.
- Drive very slowly when turning.
- Always brake going down a slope. Vehicle can take-off (freewheel) downhill.
- No loads heavier than 363 kg (800 lbs. in 6x4 Diesel. Spread loads evenly. Tie loads down.
- Reduce speed and load on rough or hilly ground.

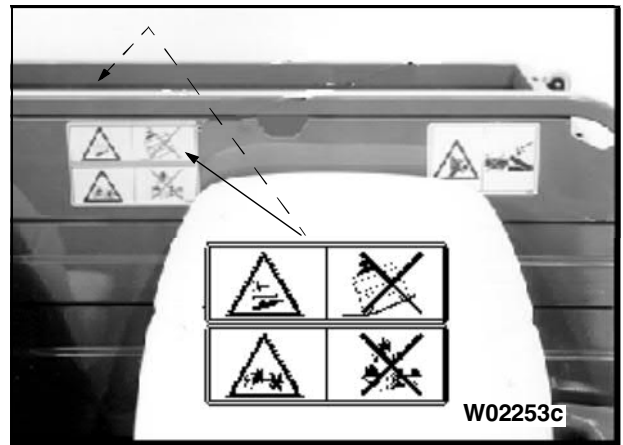

SAFETY SIGNS

CAUTION: Help Prevent Injury When Dumping Loads

- Operate dump with machine stationary and parking brake locked.
- Never dump while moving.
- Operate dump on level ground only.
- Operate dump from operator's seat only.
- Do Not place hands behind the seat when lowering box.
- Refer to Operator's Manual for correct load distribution.

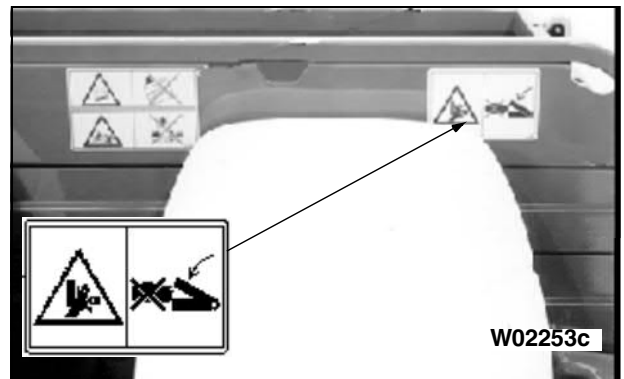

DANGER: Explosive Gases

Cigarettes, flames or sparks could cause battery to explode. Always shield eyes and face from battery. Do not charge or use booster cables or adjust post connections without proper instruction and training. Keep vent as tight and level

Poison Causes Severe Burns

Contain sulfuric acid. Avoid contact with skin, eyes or clothing. In event of accident, flush with water and call a physician immediately. Keep out of reach of children.

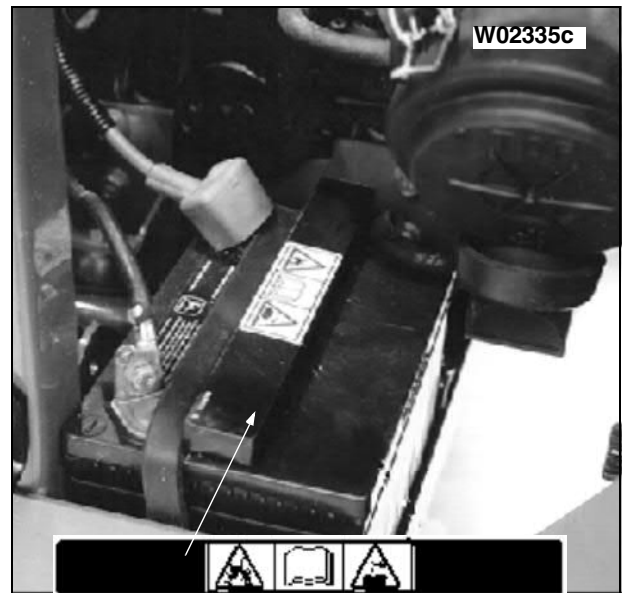

CE LABELS

This label is part of the Utility Vehicle Identification Plate on your GATOR. It indicates that your vehicle model has been certified and is in compliance with European Directive 89/392/EEC Standards

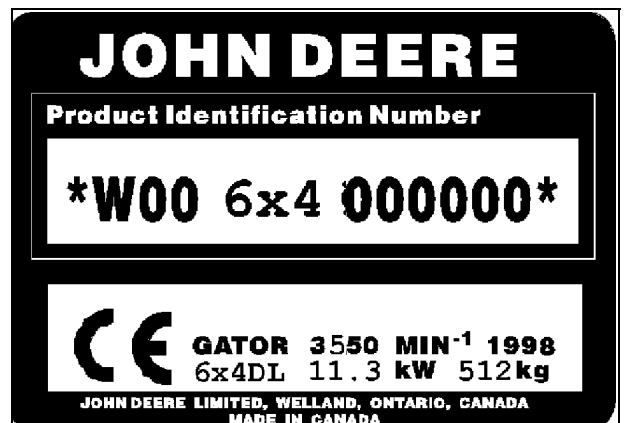

CONTROLS

Operator Controls

- A - Warning Light Switch (Optional)
- B - Indicator Panel
- C - Hourmeter
- D - Headlight Switch
- E - Horn (Optional)
- F - Accelerator
- G - Brake Pedal
- H - Key Switch
- I - Turn Signal switch and Indicator (Optional)
- J - Cargo Box Dump Switch (Optional)
- K - Differential Lock Lever
- L - Transaxle Shift Lever
- M - Parking Brake Lever
- N - Fuel Shutoff

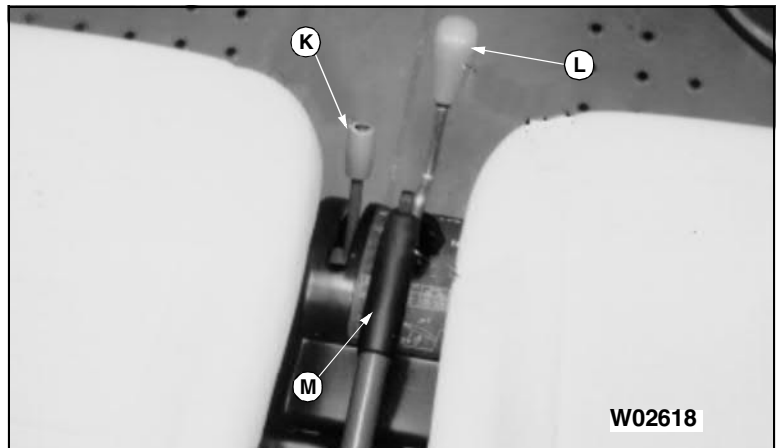
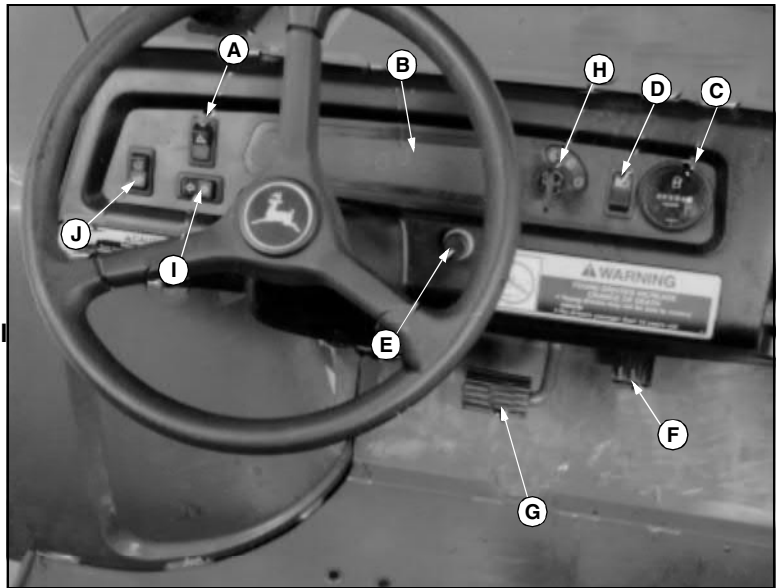

CONTROLS

Indicator Panel

- A - Battery
- B - Oil Pressure
- C - Coolant Temperature
- D - Engine Preheat
- E - Parking Brake
- F - Differential Lock

NOTE: Only one indicator bulb illuminates both Coolant Temperature (C) and Engine Preheat (D) Indicators at the same time.

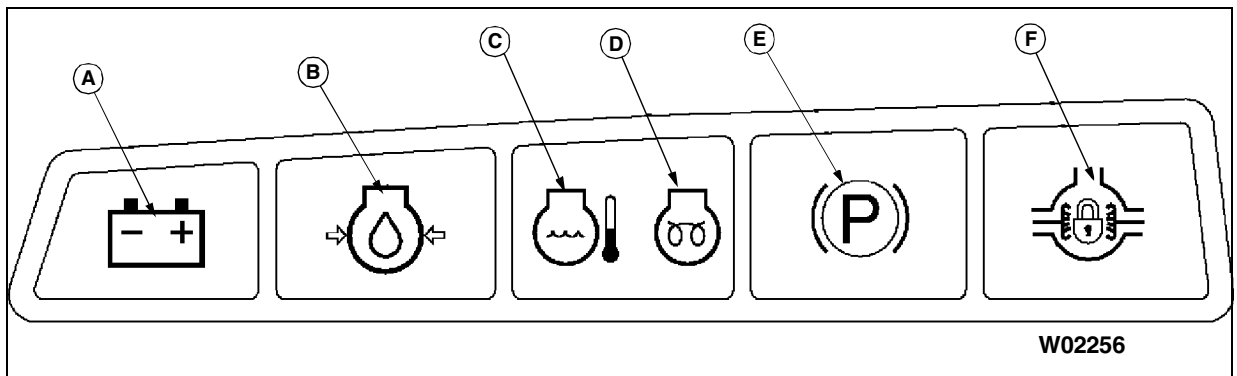

OPERATING MACHINE

Operate Safely

- View the videotape provided with the vehicle for safe operating practices.
- DO NOT misuse the GATOR[®], it is a utility vehicle NOT a recreation vehicle.
- Sit on the center of the seat and keep both feet within the foot platform perimeter. Clean foot platform if dirty, and remove any debris from around foot controls.
- Check for debris in engine compartment, especially around brake linkage on each side of the transaxle.
- Always use both hands for steering.
- Know location of controls and how and what they operate.
- Never operate utility vehicle while standing.
- Never operate utility vehicle with the cargo box raised.
- Check brake action before beginning vehicle operation. Adjust or service the brakes as necessary.
- To provide adequate braking ability and traction, DO NOT tow any attachment or loaded trailer unless the utility vehicle cargo box is loaded.
- Inspect vehicle before operating. Be sure hardware is tight. Repair or replace damaged, badly worn, or missing parts. Be sure guards and shields are in good condition and fastened in place. Make any necessary adjustments before operating.
- Keep people and pets out of the work area. Stop the vehicle if anyone enters the area. If an object is hit, stop and inspect the vehicle for damage. Make repairs before operating.
- Keep headlight lenses clean.
- DO NOT leave vehicle unattended when it is running.
- Only operate during daylight or with good artificial light.
- Be careful of traffic when operating near or crossing roadways.
- This vehicle is NOT intended for use on highways or public roadways. It is to be used for off-road use only.
- Avoid sudden starts, stops, or turns.
- Always use a level turn-around area.
- DO NOT wear headphones while operating.

OPERATING MACHINE

Avoid Tipping

Accidents resulting in serious injury or death can occur from tipping the GATOR. Observe the following practices.

Do not allow drivers younger than 16 years old, and never allow riders in the cargo box.

Drive very slowly when turning. Sharp turns could cause the utility vehicle to roll over even at slower speeds or on flat ground.

Reduce speed and exercise extreme caution on slopes or on rough ground.

Do not overload vehicle and avoid shifting loads. Reduce loads when operating over rough or hilly terrain.

Do not stop or start suddenly when going uphill or downhill. Be especially cautious when changing direction on slopes.

Stay alert for holes, rocks, and roots in the terrain, and other hidden hazards. Keep away from any drop-off.

Keep front wheels straight at crest of hill or going over bumps.

When descending a hill, remove foot from the accelerator and apply brakes to reduce speed and maintain control.

Do not make changes or modifications to the GATOR.

Use of a helmet and/or protective gear is recommended for certain operating conditions.

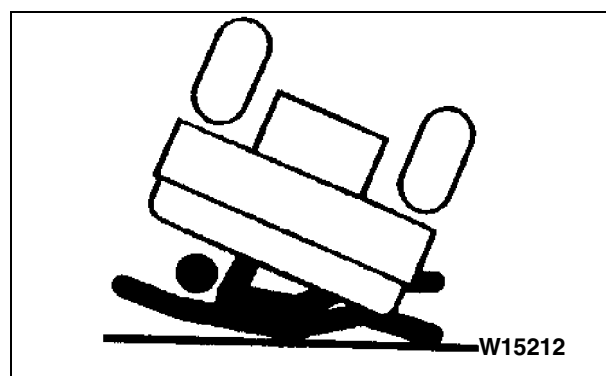
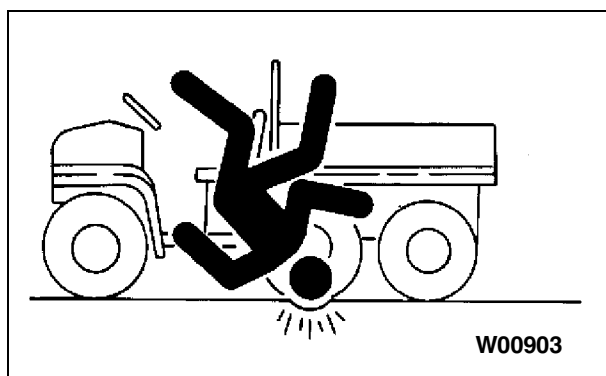

OPERATING MACHINE

Before Driving

⚠ CAUTION: Help prevent severe bodily injury or death to yourself and others due to roll-over caused by loss of control and/or stability. This vehicle is NOT intended for use on highways or public roadways. It is to be used for off-road use only.

Be sure the videotape on safe operation of vehicle is viewed by anyone operating the vehicle for the first time.

Keep children and others away when you operate the vehicle. Never carry children in the cargo area. DO NOT let children ride on the utility vehicle or any attachment.

Seating is provided for the operator and one passenger. No riders are allowed in the cargo box or anywhere else on the vehicle.

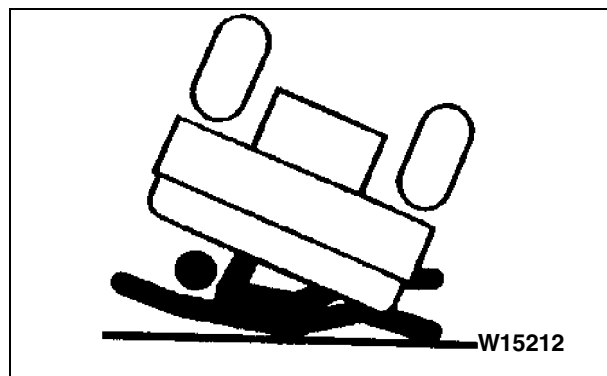

1. Clean foot platform if dirty, and remove any debris from around foot controls. Sit on the center of seat and keep both feet inside foot platform perimeter.
2. Know location of controls and how and what they operate.
3. Inspect utility vehicle for signs of wear or damage.
4. All safety equipment must be in good condition and fastened in place:
 - Load guard
 - Lights
 - Shields
 - Safety start devices
5. Before moving, check around utility vehicle, be sure no one is near it.
6. Securely anchor all loads.

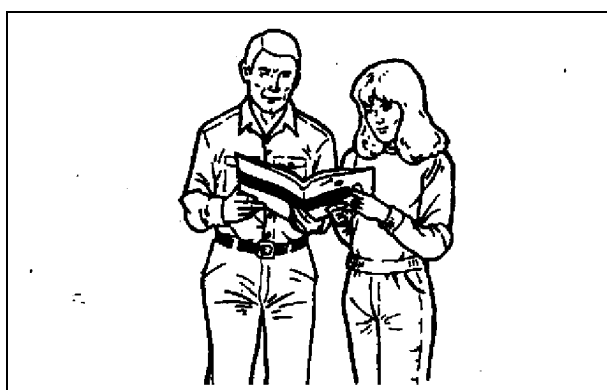

OPERATING MACHINE

Protect Children and Prevent Accidents

PROTECT CHILDREN:

- Never assume that children will remain where you last saw them. Stay alert to the presence of children.
- Never carry children in the cargo box area. **DO NOT** let children ride in the cargo box of the utility vehicle or any attachment. **DO NOT** tow children in a cart or trailer.
- Use extra care when coming to blind corners, shrubs, trees, or other objects that may block vision.
- **DO NOT** let children or an untrained person operate the vehicle.
- Before backing or turning, look behind and around the utility vehicle for children.

HELP PREVENT SERIOUS OR FATAL ACCIDENTS:

- Be alert at all times, drive forward and in reverse carefully. People, especially children, can move quickly into an area of operation.
- Back carefully. Look behind the vehicle, especially for children, before backing up.
- **DO NOT** operate vehicle if under the influence of alcohol or other drugs.
- Misuse and recreational riding can lead to accidents, severe bodily injury or death.

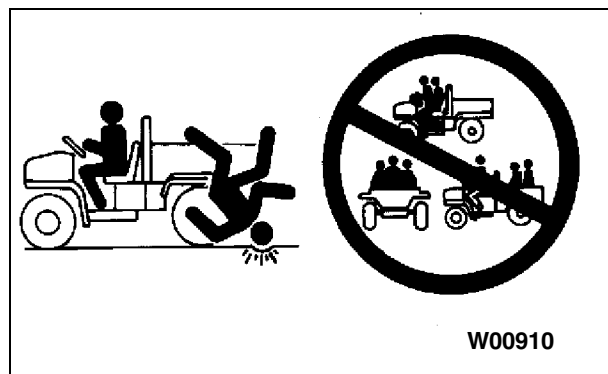

W00910

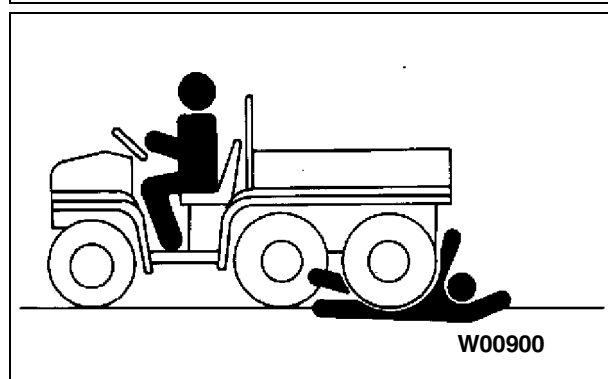

W00900

Park Safely

1. Stop the vehicle on a level surface, not on a slope.
2. Engage park brake.
3. STOP engine.
4. Remove key.
5. Before you leave the operator's seat, wait for engine and all moving parts to STOP.

Use Hand Holds

hand holds (A) are provided for passenger balance when driving over rough terrain. Use both dash bar and side rails on seat for stability.

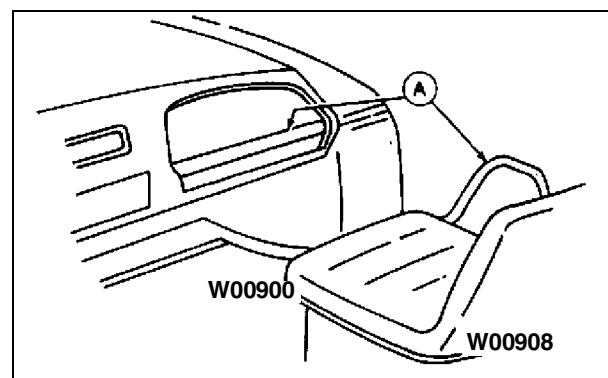

W00900

W00908

OPERATING MACHINE

Operator Training Required

Study operation section of this manual before operating the vehicle.

- Operate vehicle in an open, unobstructed area under the direction of an experienced operator.
- Learn the use of all controls.
- Operator experience is required to learn the moving, stopping, turning and other operating characteristics of the vehicle.
- Young drivers may not have the strength or experience to control the utility vehicle. This increases the chances of rolling the vehicle over resulting in severe bodily injury or death.
- The utility vehicle should NOT be operated by anyone under the age of 16 years.

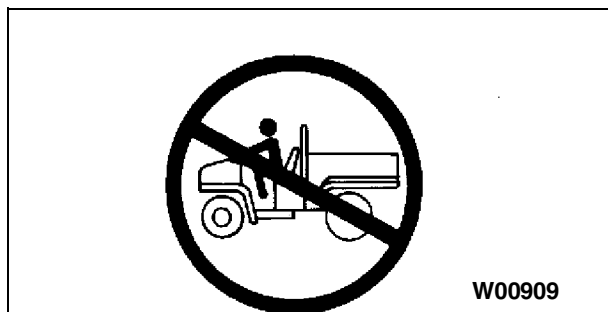

No Driving On Public Roads

CAUTION: This vehicle is NOT intended for use on highways or public roadways. It is to be used for off-road utility use only. Do not operate utility vehicle on a public roadway or highway where GATOR may be a hazard to faster moving traffic.

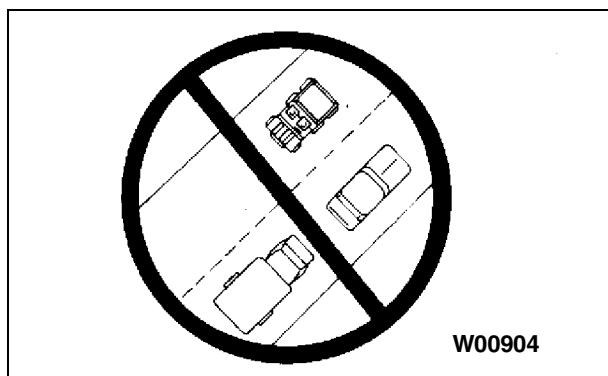

Before you drive utility vehicle, be sure:

Reflective tape is clean.

Headlight, taillight, brake lights lenses are clean and operate.



OPERATING MACHINE

Keep Riders Off Vehicle

- Seating is provided for operator and one passenger. No riders are allowed in cargo box or anywhere else on vehicle.
- Riders on vehicle are subject to injury such as being struck by foreign objects or being thrown off of the vehicle and severely injured or killed.
- Riders affect the operator's ability to control the vehicle as well as its center of gravity. Also, riders could obstruct the operator's view resulting in the vehicle being operated in an unsafe manner.

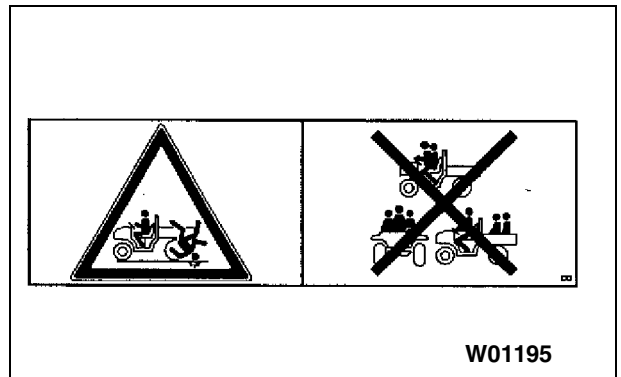

OPERATING MACHINE

Driving On Rough Or Hilly Terrain

CAUTION: Help prevent severe bodily injury or death due to loss of control. Reduce load when operating over rough or hilly terrain. Reduce speed when turning or when operating around obstacles or rough terrain. Check the terrain and know the operational capability of the vehicle. Choose places to operate carefully.

- Horseplay or recreational riding can lead to accidents, severe bodily injury or death.
- Always use the brakes when going down slopes. The utility vehicle can speed-up (freewheel) going down a slope. When carrying a load, be sure load is evenly distributed and secured. Braking could shift the load and affect vehicle stability. Due to belt drive, engine and/or clutch, braking effect can be minimal.
- Use existing trails. Avoid terrain such as dangerous slopes and impassable swamps. Watch carefully for sharp bumps, holes, ruts, or obstacles.
- Look ahead at terrain. Know what is coming and be prepared to react. Be alert for hazards.
- Keep front wheels straight at crest of hill or going over bumps.
- Adjust speed according to trail, terrain, and visibility conditions.
- Use of a helmet and or protective gear is recommended for certain operating conditions.

Check Wheel Bolts

IMPORTANT: Overtightening of front wheel bolts may result in bearing damage.

- A serious accident could occur causing serious injury if wheel bolts are not tight.
- Check wheel bolt tightness after first 10 hours of vehicle operation and every 200 hours thereafter.
Picture Note: Tighten in order of letters on photo.
- Tighten front wheel bolts to 90 N•m (65 lb-ft.).
- Tighten bolts on the drive wheels to 100 N•m (75 lb-ft.)

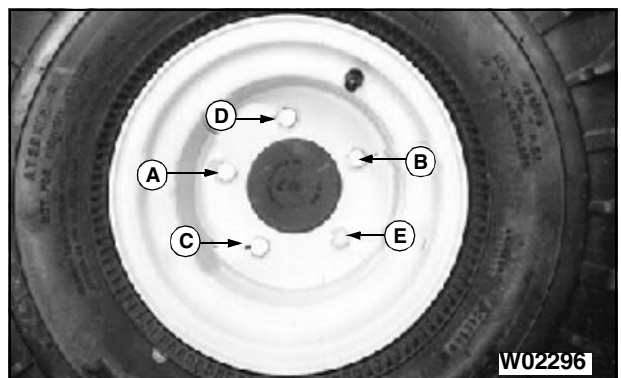
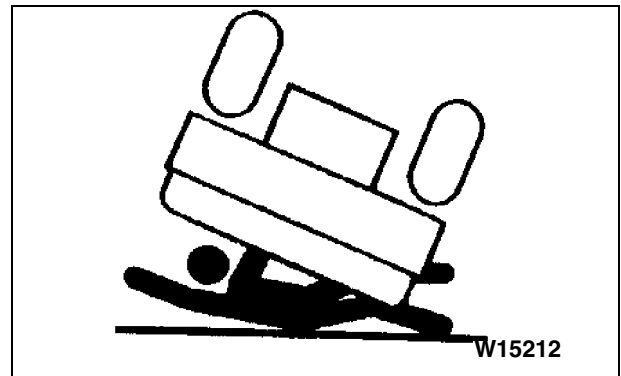
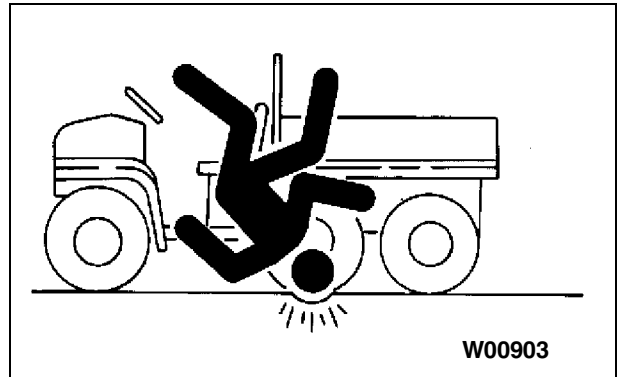

OPERATING MACHINE

Climbing Or Descending A Hill

CAUTION: Help prevent severe bodily injury or death due to loss of control. Reduce load when operating over rough terrain. Due to belt drive there is minimal engine braking effect, utility vehicle will freewheel going down slopes. Reduce speed when turning or when operating around obstacles or on rough ground.

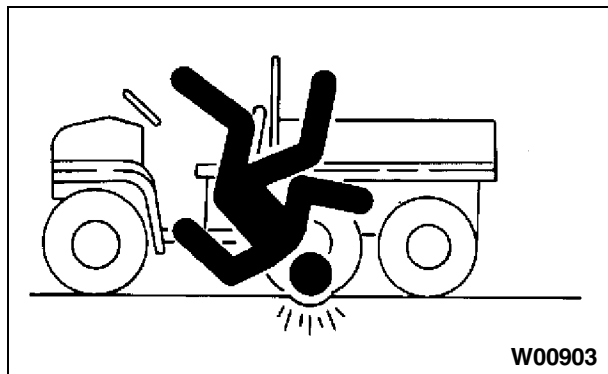

- Always use the brakes when going down slopes. The utility vehicle can speedup (freewheel) going down a slope. When carrying a load, be sure they are loaded evenly and secured. Braking could shift the load and affect vehicle stability. Due to belt drive, engine and/or clutch braking effect is minimal.
- Sit on center of seat and keep both feet within foot platform.
- Never drive past the limit of visibility. Slow down near crest of hill until getting a clear view of the other side.
- Keep front wheels straight at crest of hill or going over bumps.
- DO NOT stop or start suddenly when going uphill or downhill. Be especially cautious when changing direction on slopes.
- If vehicle stops or loses power going up a hill, apply park brake to hold vehicle on slope. Maintain direction of travel and release brake slowly. Back straight down hill slowly while maintaining control. DO NOT turn vehicle sideways. Vehicle is more stable in a straight forward or rearward position.
- When descending a hill, remove foot from accelerator and apply brakes to reduce speed and maintain control.
- Use of a helmet and/or protective gear is recommended for certain operating conditions.

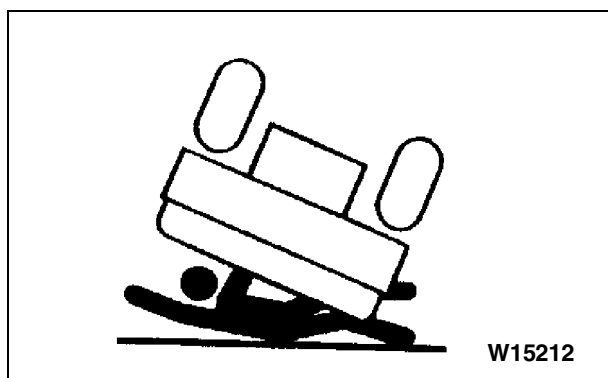

OPERATING MACHINE

Driving Across Slopes

CAUTION: Help prevent severe bodily injury or death due to tipping or loss of control. Reduce speed and exercise extreme caution on slopes and in sharp turns. Be especially cautious when changing direction on slopes.

- Sit on center of seat and keep both feet within foot platform perimeter.
- Stay alert for holes, rocks and other hidden hazards in the terrain.
- When riding on soft terrain, turn front wheels slightly uphill to keep utility vehicle on a straight line across the hill.
- If utility vehicle begins to tip, turn front wheel downhill to gain control before proceeding.
- Use of a helmet or protective gear is recommended for certain operating conditions.

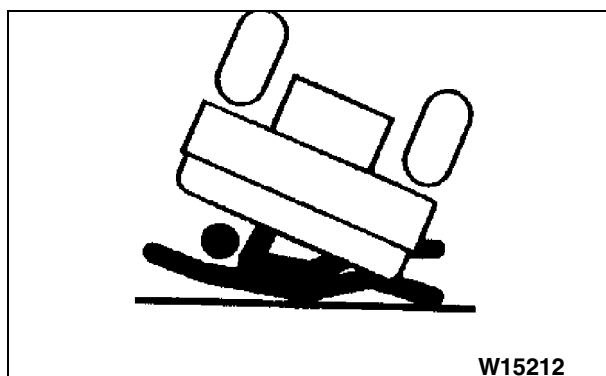
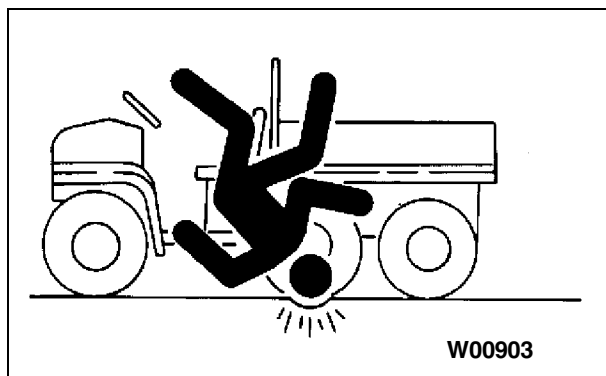

Riding Through Water

CAUTION: Help prevent severe bodily injury or death due to loss of vehicle control.

- Avoid water whenever possible. If drive belt becomes wet, slippage will occur and vehicle will lose power.
- Sit on center of seat and keep both feet within foot platform perimeter.
- Reduce speed while driving through water.

Never cross any body of water where depth may be unknown to the operator. As an operational guideline, deep water is considered anything in excess of 152 mm (6 in.) in depth. Tires may float, making it difficult to maintain control.

- Choose a course within the waterway where both banks have a gradual incline. Cross at a point known to be safe.
- Proceed at a slow steady speed to avoid submerged obstacles and slippery rocks.
- Avoid water crossings where the operation of a utility vehicle may cause damage to waterway beds or erode waterway shoreline.





Suggest:

If the above button click is invalid.

Please download this document

first, and then click the above link

to download the complete manual.

Thank you so much for reading

OPERATING MACHINE

Using Fuel Shut-Off Valve

1. Lift and tip operator seat forward.
2. Turn knob (A) to shut OFF or turn ON fuel flow. Arrow on knob should face upward for fuel flow to be ON.

NOTE: The fuel shut-off valve should be closed if the vehicle is to be transported or placed in extended storage.

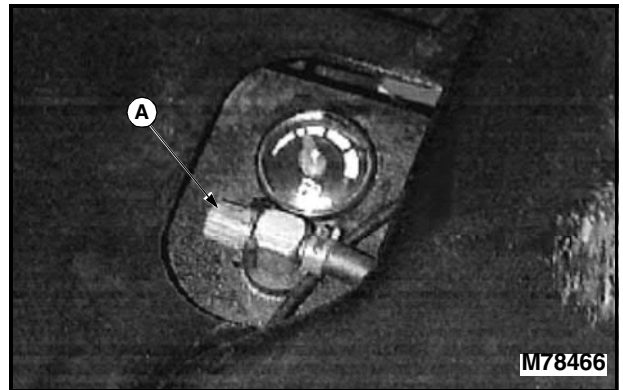

Operating Brake and Accelerator Pedals

CAUTION: Help prevent bodily injury due to loss of control, load shifting and/or tipping. Reduce speed before braking, when turning, when hauling loads at higher speeds, when operating around obstacles, and when operating on any hazardous off-road conditions.

Release accelerator (A) and apply brake pedal (B) evenly and firmly to slow down or stop.

Avoid hard braking applications.

Push down accelerator slowly and smoothly.

Before braking remove foot from the accelerator pedal.

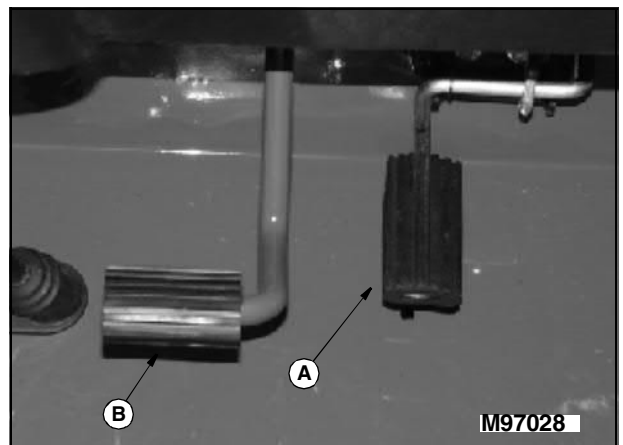

Using Park Brake

NOTE: Applying foot brake pedal while engaging and disengaging park brake decreases effort required to pull or push park brake lever.

- To ENGAGE park brake:
 - Pull up lever (A) and latch into position.
- To DISENGAGE park brake:

Picture Note: Decal located on console below park brake lever.

- Pull up on lever (A).
- Depress button (B).
- Push lever (A) down.

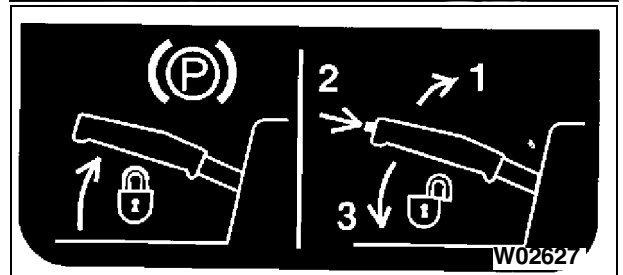
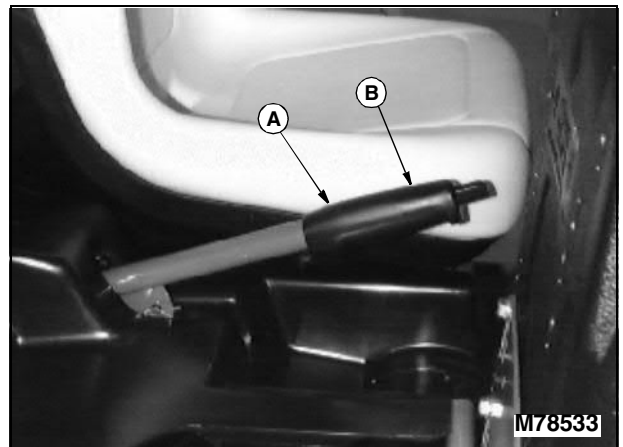

<https://www.ebooklibonline.com>

Hello dear friend!

Thank you very much for reading.

Enter the link into your browser.

The full manual is available for immediate download.

<https://www.ebooklibonline.com>