

F725

Front Mowers

Serial No. (090001-)

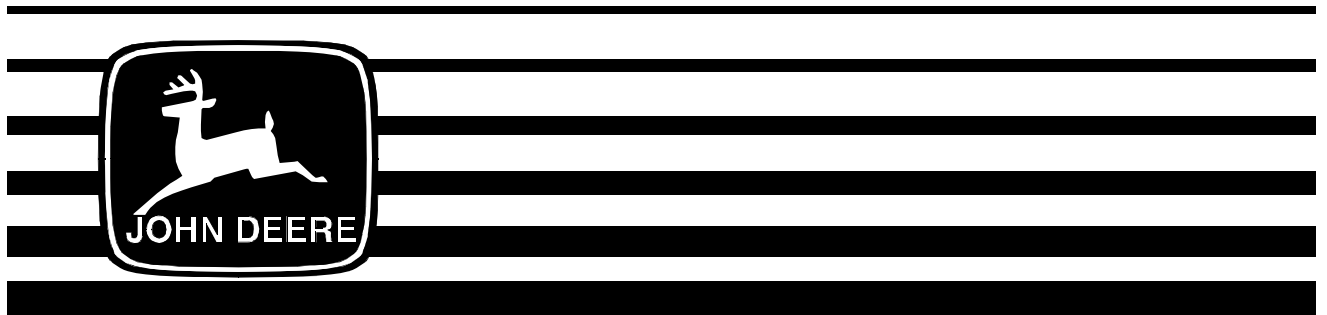

OPERATOR'S MANUAL

John Deere
Worldwide Commercial And
Consumer Equipment Division
OMM134807 A9

North American
Litho in U.S.A.
English

INTRODUCTION

THANK YOU for purchasing a John Deere product.

Read this manual thoroughly. Failure to do so could result in personal injury or equipment damage.

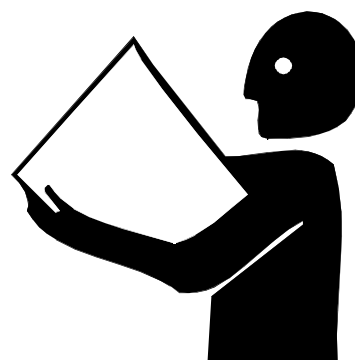

WARNING: The Engine Exhaust from this product contains chemicals known to the State of California to cause cancer, birth defects or other reproductive harm.

CALIFORNIA Proposition 65 Warning

This manual should be considered a permanent part of your machine and should remain with the machine when you sell it.

Measurements in this manual are metric units and their U.S. customary equivalents. RIGHT-HAND and LEFT-HAND sides are determined by facing in the direction the machine will travel when going forward. When you see a broken line arrow (----->), it indicates the part it is pointing to is hidden.

Record identification numbers below. Be sure to record all the numbers to help in tracing the machine if it is stolen. You also need to give these numbers to your dealer when you order parts.

**FRONT MOWER
SERIAL NUMBER (A) :** _____

**ENGINE SERIAL
NUMBER (B) :** _____

**MOWER DECK
SERIAL NUMBER (C) :** _____

**DATE OF
PURCHASE :** _____

**DEALER
NAME :** _____

**DEALER
PHONE :** _____

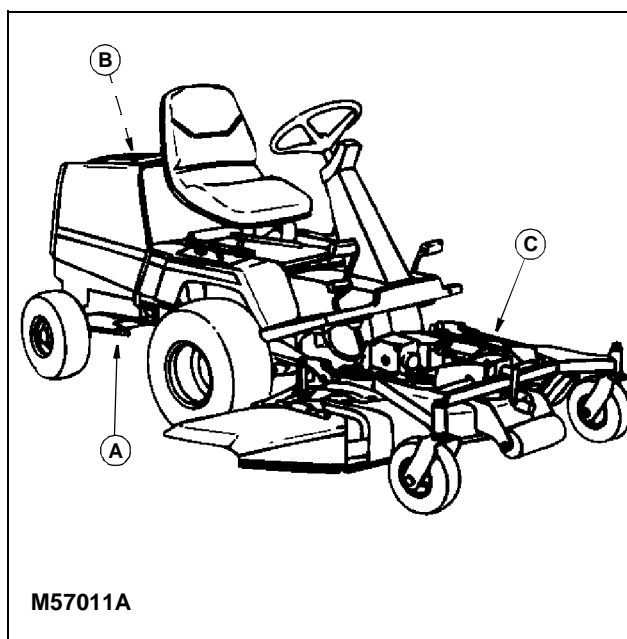

TABLE OF CONTENTS

Safety Signs	1
Controls	4
Operating Machine	7
Operating Mower	29
Lawn Care	35
Replacement Parts	39
Service Machine Safely	40
Service Interval Chart.	42
Service - Engine	45
Service - Transmission	58
Service - Steering And Brakes	62
Service - Mower	65
Service - Electrical	74
Service - Miscellaneous	82
Removing And Storing The Mower.	85
Installing The Mower.	87
Troubleshooting	90
Storing Machine	94
Assembly	96
Specifications	100
Warranty	108
Index	112
John Deere Service Literature	115

All information, illustrations and specifications in this manual are based on the latest information at the time of publication. The right is reserved to make changes at any time without notice.

COPYRIGHT© 1999
Deere & Co.
John Deere Worldwide Commercial and
Consumer Equipment Division
Horicon, WI
All rights reserved
Previous Editions
COPYRIGHT© 1998, 1997

OMM134807 A9

<https://www.ebooklibonline.com>

Hello dear friend!

Thank you very much for reading.

Enter the link into your browser.

The full manual is available for immediate download.

<https://www.ebooklibonline.com>

SAFETY SIGNS

Safety-Alert Symbol

Read and recognize safety information. Be alert to the potential for personal injury when you see this safety-alert symbol.

On your machine safety labels, the words DANGER, WARNING, and CAUTION are used with this safety-alert symbol. DANGER identifies the most serious hazards. In this manual, the word CAUTION and this symbol call attention to safety messages.

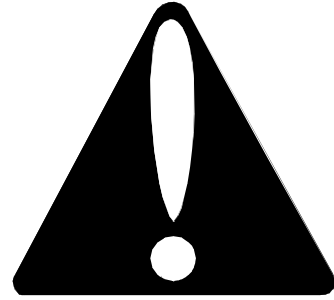

Machine Safety Labels

WARNING: Hot Surface

One on each side (rear) of Front Mower.



DANGER: Rotating Blade

To avoid injury from rotating blades, stay clear of deck edge.



SAFETY SIGNS

Machine Safety Labels (Continued)

DANGER: Rotating Blade

To avoid injury from rotating blades and thrown objects, stay clear of deck edge and keep others away.

Do not mow without discharge chute or entire grass catcher in place.

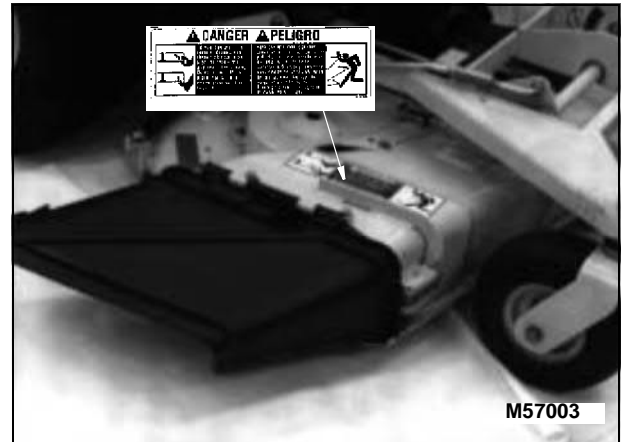

DANGER: Explosive Gases

Cigarettes, flames or sparks could cause battery to explode.

Always shield eyes and face from battery.

Do not charge or use booster cables or adjust post connections without proper instruction and training.

Keep vent caps tight and level.

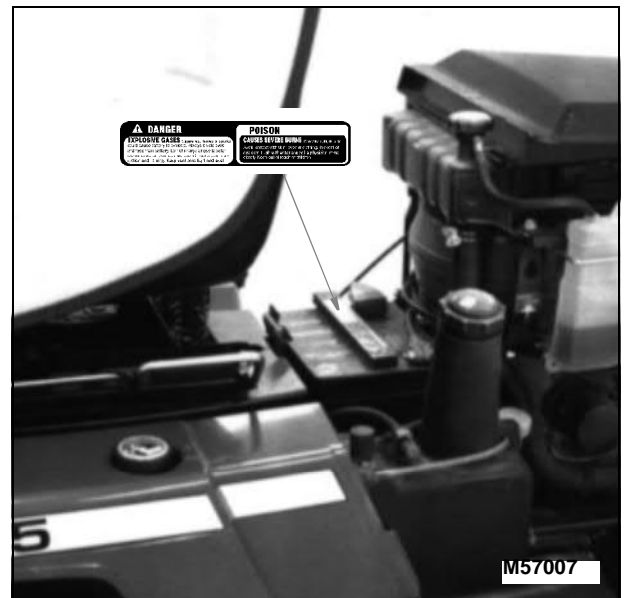

Poison: Causes Severe Burns

Contains sulfuric acid.

Avoid contact with skin, eyes or clothing.

In event of accident, flush with water and call a physician immediately.

Keep out of reach of children.

SAFETY SIGNS

CAUTION: Help Avoid Injury

- Read operators manual for training.
- Know location and function of controls.
- Keep safety devices (guards, switches) in place and working.
- Never carry children.
- Look behind before backing.
- Keep children and others away when operating machine.
- Stop engine before placing hands or feet near power driven parts.
- Do not drive where machine could slip or tip.
- If machine stops, going up hill, shut off PTO and back down slowly.
- Before leaving machine:
 - Stop engine
 - Set park brake
 - Remove key



DANGER:

To avoid injury to children, stop mower when children are near. Do not mow in reverse. Look behind when backing. Never carry riders, especially children.

Compliance Label

This label on your machine indicates that this model has been tested and evaluated by the manufacturer and conforms to rotary mower requirements of the American National Standard B-71.4.1990 for Commercial Turf Care Equipment Safety Specification.

THIS MODEL HAS BEEN TESTED AND EVALUATED BY THE MANUFACTURER AND CONFORMS TO ALL APPLICABLE ROTARY MOWER REQUIREMENTS OF ANSI B71.4 - 1990 AMERICAN NATIONAL STANDARD FOR COMMERCIAL TURF CARE EQUIPMENT SAFETY SPECIFICATION

CONTROLS

Panel Controls

- A - Key Switch
- B - PTO Switch
- C - Park Brake Lever
- D - Throttle Lever
- E - Hour Meter

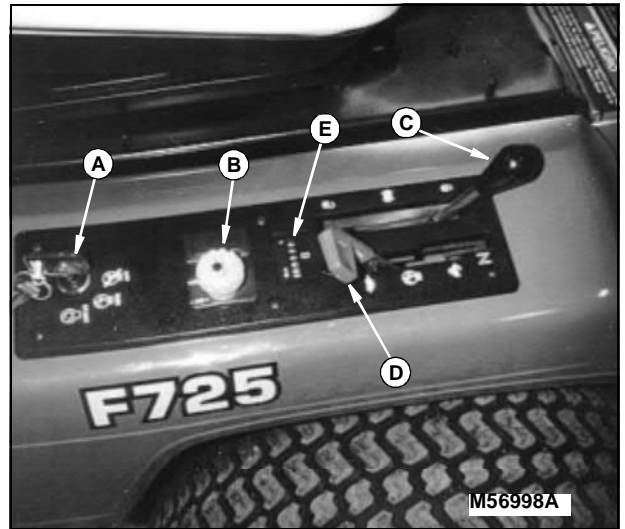

Foot Controls

- A - Brake Pedal
- B - Forward Travel Pedal
- C - Reverse Travel Pedal
- D - Differential Lock Pedal

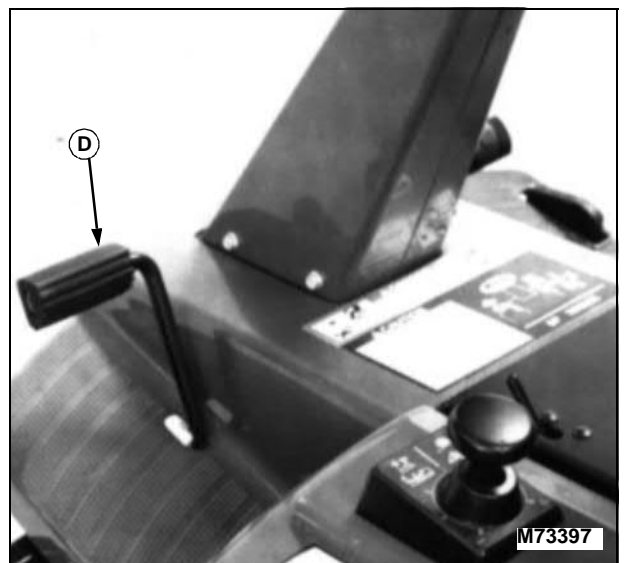
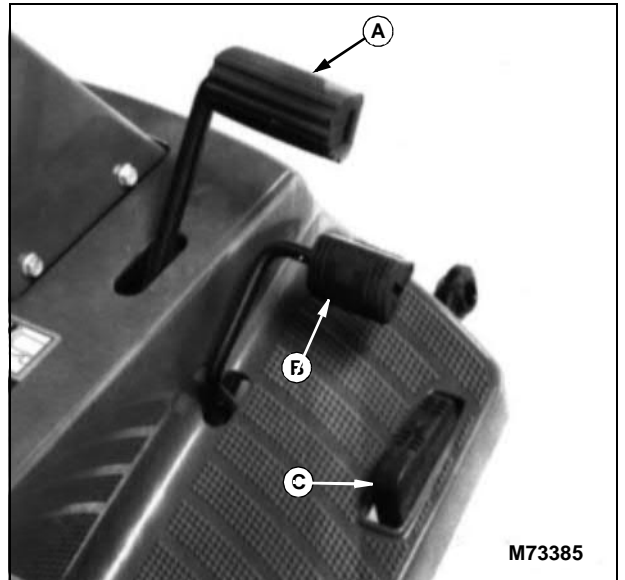

CONTROLS

Weight Transfer Control

A - Weight Transfer Control

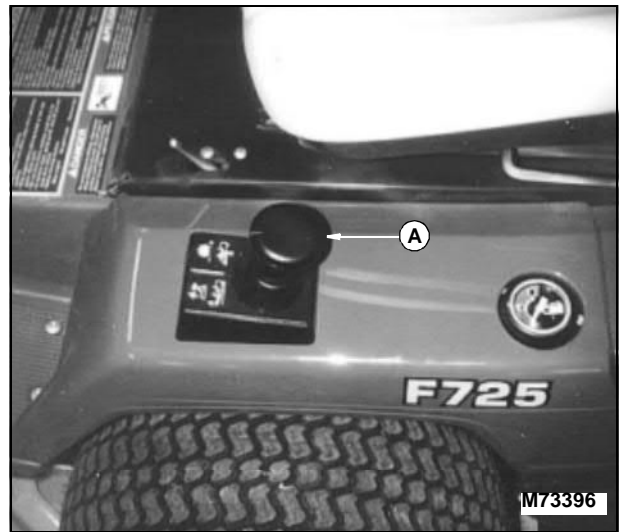

Indicator Lights

A - Indicator Lights



Seat Controls

- A - Handle
- B - Seat Release Lever
- C - Seat Control Lever

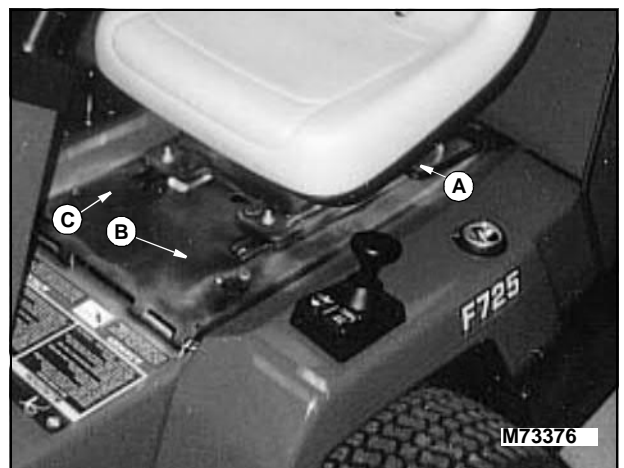

CONTROLS

Free-Wheeling Lever

A - Free-Wheeling Lever

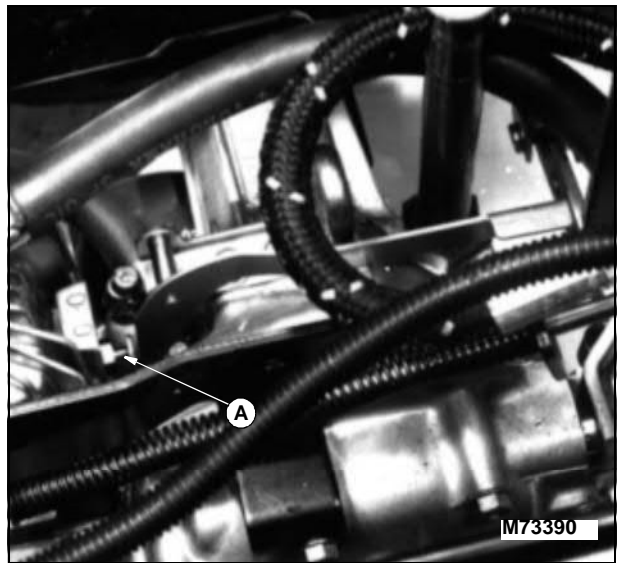

OPERATING MACHINE

Operate Safely

- Check vehicle brake action before you operate. Adjust or service brakes as necessary.
- Clear work area of objects that might be thrown. Keep people and pets out of the work area. Stop machine if anyone enters the area.
- If you hit an object, stop the machine and inspect it. Make repairs before you operate. Keep machine and attachments properly maintained and in good working order. Keep all shields and guards in place.
- DO NOT leave machine unattended when it is running.
- Only operate during daylight or with good artificial light.
- Be careful of traffic when operating near or crossing roadways.
- Get on the Front Mower from the LEFT SIDE ONLY.
- Raise and lower the seat from the LEFT SIDE ONLY.
- Start the engine from the operator's seat only.
- Keep your feet on the platform.
- When driving the Front Mower:
 - a. Without an attachment, drive slowly and avoid quick stops.
 - b. With the snowthrower installed, order the Rear Weight Kit. See your John Deere dealer for these weights.
- Check the seat mounting at regular intervals. Tighten the hardware, if necessary. If you find cracks or rust in the seat base or seat, replace the seat immediately.

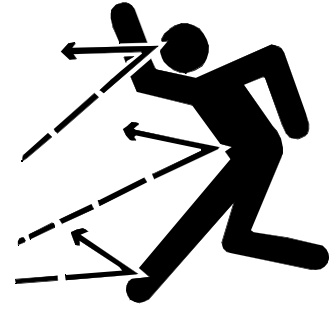

OPERATING MACHINE

Park Safely

- Stop machine on a level surface, not on a slope.
- Disengage PTO.
- Lower attachments to the ground.
- Engage park brake.
- STOP engine.
- Remove key.
- Before you leave the operator's seat, wait for engine and all moving parts STOP.

Operator Training Required

- Study operation section of this manual before operating the machine.
- Operate machine in an open, unobstructed area under the direction of an experienced operator.
- Learn the use of all controls.
- Operator experience is required to learn the moving, stopping, turning and other operating characteristics of the machine.

Wear Appropriate Clothing

- Wear close fitting clothing and safety equipment appropriate for the job.
- Loud noise can cause impairment or loss of hearing, wear a suitable protective device such as earplugs.
- Do not wear radio or music headphones while operating the machine. Safe operation requires your full attention.

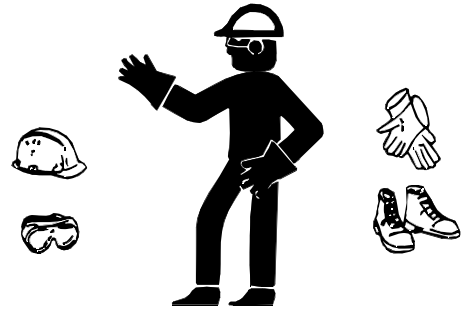

OPERATING MACHINE

Rotating Blades Are Dangerous - Protect Children And Prevent Accidents

PROTECT CHILDREN:

- Never assume that children will remain where you last saw them. Children are attracted to mowing activity, stay alert to the presence of children.
- Keep children in the house when you are operating the machine.
- Turn machine off if a child enters the mowing area.
- Use extra care when you come to blind corners, shrubs, trees, or other objects that may block your vision.
- DO NOT let children or untrained person operate the machine.
- DO NOT carry or let children ride on machine or any attachment. DO NOT tow children in a cart or trailer.

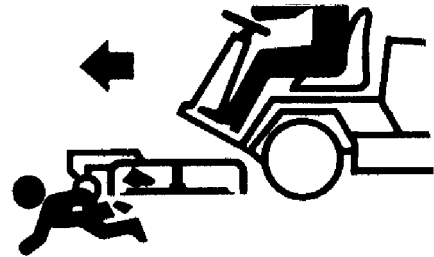
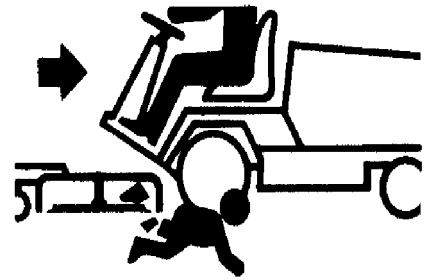

HELP PREVENT SERIOUS OR FATAL ACCIDENTS:

- Be alert at all times, drive forward carefully. People **ESPECIALLY CHILDREN** can move quickly into the mowing area before you know it.
- Back carefully. Shut off PTO and look behind the machine carefully, **ESPECIALLY FOR CHILDREN**, before you back up.
- DO NOT mow in reverse unless it is absolutely necessary.
- Shut off PTO when you are not mowing.
- DO NOT operate machine if you are under the influence of drugs or alcohol.

Avoid Tipping

- DO NOT drive where machine could slip or tip.
- Stay alert for holes and other hidden hazards in the terrain.
- Keep away from drop-offs.
- Slow down before you make a sharp turn or operate on a slope.



OPERATING MACHINE

- When pulling loads or using heavy equipment, use only approved hitches, limit loads to those you can safely control, and use counterweights or wheel weights when required per this manual or your attachment manual.
- Drive up and down a hill - not across. Be careful when you change direction on a slope.
- DO NOT stop when going up hill or down hill. If machine stops going up hill, STOP PTO and back down slowly.
- DO NOT mow wet grass. Reduced traction could cause sliding.
- DO NOT try to stabilize the machine by putting your foot on the ground.

Keep Riders Off

- Only allow the operator on the machine. Keep riders off.
- Riders on the machine or attachment may be struck by foreign objects or thrown off the machine causing serious injury.
- Riders obstruct the operator's view resulting in the machine being operated in an unsafe manner.



Check Wheel Bolts

- A serious accident could occur causing serious injury if wheel bolts are not tight.
- Check wheel bolt tightness often during the first 100 hours of operation.

OPERATING MACHINE

Transport Safely

- Use safety lights and devices. Slow moving machines when driven on public roads are hard to see, especially at night. Avoid personal injury or death resulting from a collision with a vehicle.
- Flashing warning lights are recommended whenever driving on public roads to increase visibility. Extra flashing warning lights may need to be installed.
- A safety lighting kit is available from your John Deere dealer.

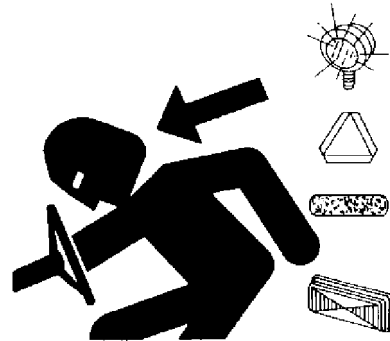

Towing Loads

CAUTION: BE CAREFUL ON SLOPES: Pulling a heavy load on a slope may cause you to lose control of steering, and may result in personal injury. Do not tow children in a cart or trailer. LOOK FOR CHILDREN before you back a load.

- Use **ONLY** the drawbar to pull trailers, carts, or light attachments
- Do not tow more than 318 kg (700 lb) gross weight.
- Tow only loads you can safely control.
- Be careful when you back a loaded trailer, cart, or attachment. **LOOK FOR CHILDREN** before you back.

OPERATING MACHINE

Using Key

- Turn the key straight ahead to the OFF position.
- Turn the key to the first or RUN position: Two indicator lights should go ON.
- Turn the key to the second or START position to START the engine: The coolant temperature light should go ON.



Using PTO Switch Knob

- To turn the switch ON: Pull knob up.
- Push the knob down to the OFF position.

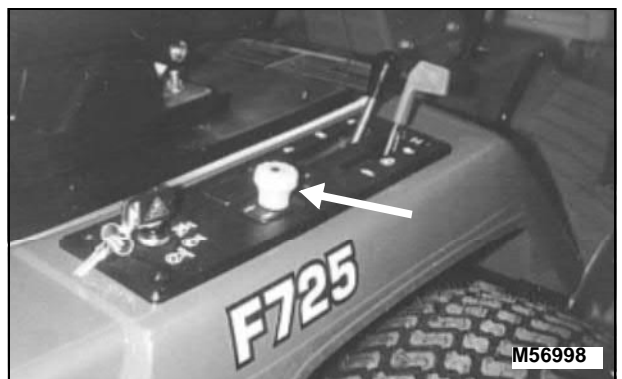

Using Park Brake Lock Lever

- Use this lever to LOCK and UNLOCK the park brake.



OPERATING MACHINE

Raising And Lowering The Hood

To raise the hood:

1. Push and hold the hood latch forward.
2. Lift the hood a short distance with your hand at the top, center of the hood.
3. Release the latch.
4. Open the hood all the way.

To lower the hood:

1. Do not drop the hood to latch it: Lower the hood to the latch.
2. Then push the hood down to latch it.

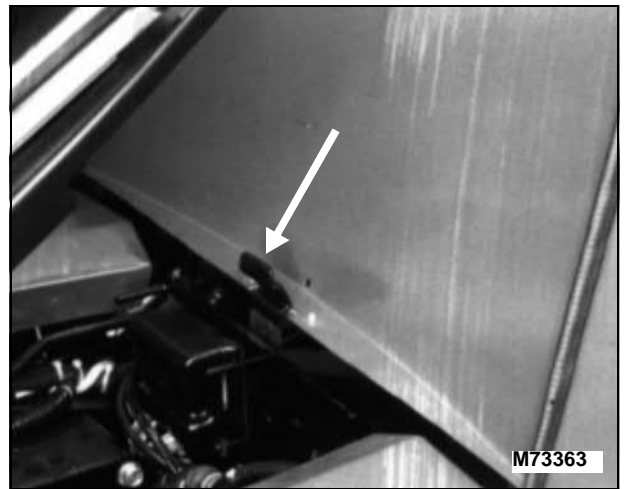

Adjusting The Hood Latch

NOTE: *The battery has been removed for this picture.*

1. Loosen the two nuts (A).
2. Move the latch up or down to the desired position.
3. If the adjustment is correct, the latch should hold the hood tightly. You should have to push the hood down slightly when you close it to latch the hood.

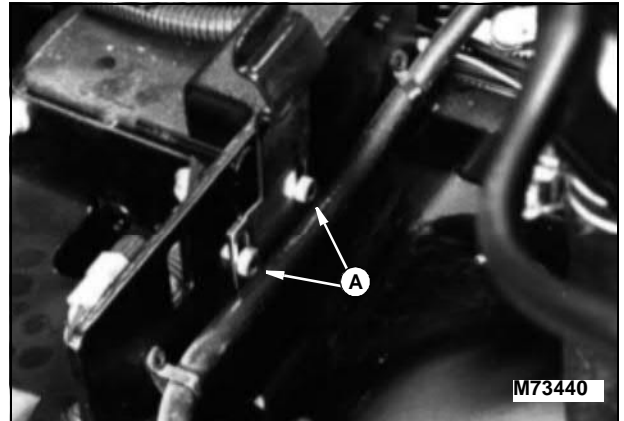

OPERATING MACHINE

Using Throttle Lever

- Push lever (A) forward to FAST (🐾) position. Operate mower with the lever in this position.
- Move the lever to the rear to the SLOW (🐌) position. Do not run the engine at SLOW throttle any longer than necessary.
- Move the lever all the way forward to the CHOKE (🔒) position to start the engine.
- Pull the lever back as the engine warms.

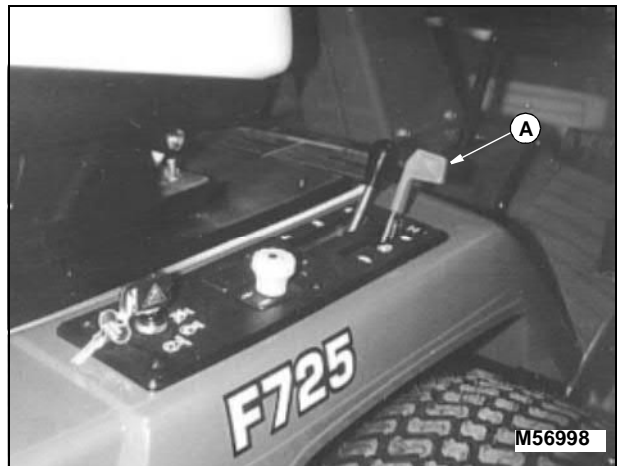

Indicator Lights

A-OIL PRESSURE INDICATOR

IMPORTANT: If the indicator lights RED when the engine is running, STOP THE ENGINE IMMEDIATELY, or the engine may be seriously damaged from lack of lubrication. Before you run the engine, find and correct the cause.

- The RED indicator light (A) means the oil is low and/or the oil pressure is low.
- The indicator should light when you turn the key switch to ON.
- The light should go out when the engine starts.



B-BATTERY INDICATOR

IMPORTANT: If the indicator lights YELLOW when the engine is running, STOP THE ENGINE. Find and correct the cause or the battery will lose power.

- The YELLOW indicator light (B) means the battery is not getting enough charge from the alternator.
- The indicator should light when you turn the key to RUN.
- The light should go out when the engine starts.

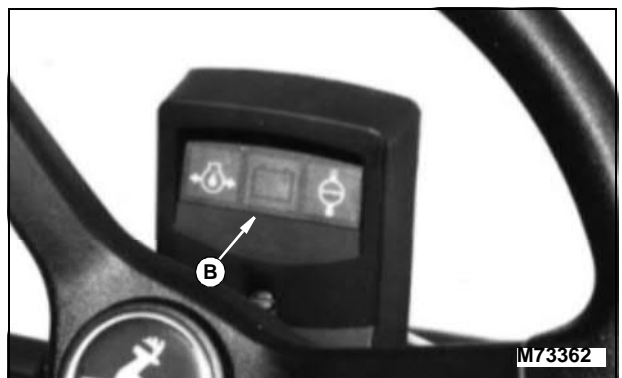



Suggest:

If the above button click is invalid.

Please download this document

first, and then click the above link

to download the complete manual.

Thank you so much for reading

OPERATING MACHINE

C-ENGINE COOLANT TEMPERATURE INDICATOR

IMPORTANT: If the indicator lights RED when the engine is running, STOP THE ENGINE. Find and correct the cause, or you may damage the engine.

- The RED indicator light (C) means the engine coolant is too HOT.
- The indicator should not light when you turn the key to RUN.
- The light should go ON when you turn the key to START, and should go out when the engine starts.



Using Forward Travel Pedal

CAUTION: Before you move the Front Mower forward, check for bystanders, ESPECIALLY CHILDREN.

- Push the pedal down to travel forward. Push the pedal further to travel faster.
- Release the pedal: it will return to neutral and stop the Front Mower.



Using Park Brake Pedal

- Push park brake pedal (A) down for an EMERGENCY STOP.

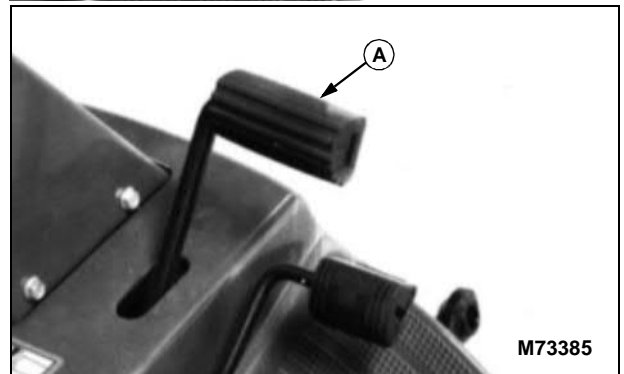

- When you push the pedal down, the travel pedal (B or C) will return to NEUTRAL and the PTO will stop.
- You must hold the pedal down or LOCK park the brake before you can start the engine.

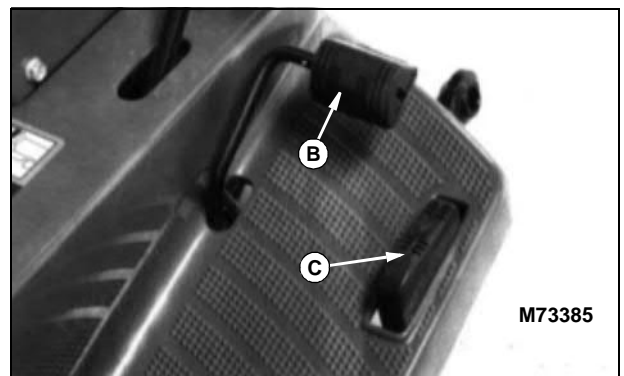

<https://www.ebooklibonline.com>

Hello dear friend!

Thank you very much for reading.

Enter the link into your browser.

The full manual is available for immediate download.

<https://www.ebooklibonline.com>